

**GAUTENG DEPARTMENT OF EDUCATION  
GAUTENGSE DEPARTEMENT VAN ONDERWYS**

**SENIOR CERTIFICATE EXAMINATION  
SENIORSERTIFIKAAT-EKSAMEN**

**WOODWORK / HOUTWERK SG  
stel)**

**Possible Answers  
Feb / Mar 2006**

**QUESTION 1A / VRAAG 1A**

1.1	A		1.11	C	
1.2	A		1.12	D	
1.3	D		1.13	A / B	
1.4	D		1.14	D	
1.5	B		1.15	D	
1.6	A		1.16	C	
1.7	B		1.17	D	
1.8	B		1.18	C	
1.9	A		1.19	A	
1.10	B		1.20	C	(20)

**QUESTION 1B / VRAAG 1B**

1.21	A		1.26	B	
1.22	B		1.27	A	
1.23	B		1.28	B	
1.24	C		1.29	C	
1.25	C		1.30	C	(10)
					<b>[30]</b>

**QUESTION 2 / VRAAG 2**

2.1	A	6		J	1
	B	5		K	3
	C	2		L	3
	D	1		M	3
	E	6		N	2
	F	2		O	1
	G	7		P	4
	H	6		Q	5
	I	1			
(17)					
2.2					
2.2.1	(i)	Type of wood	(i)	Soort hout	
	(ii)	Quality of logs	(ii)	Kwaliteit van blokke	
	(iii)	Sizes required	(iii)	Grootes wat verlang word	
	(iv)	Purpose for which timber should be used	(iv)	Doel waarvoor gebruik hout gaan word	(4)

2.2.2

(i) Cross-cutting method

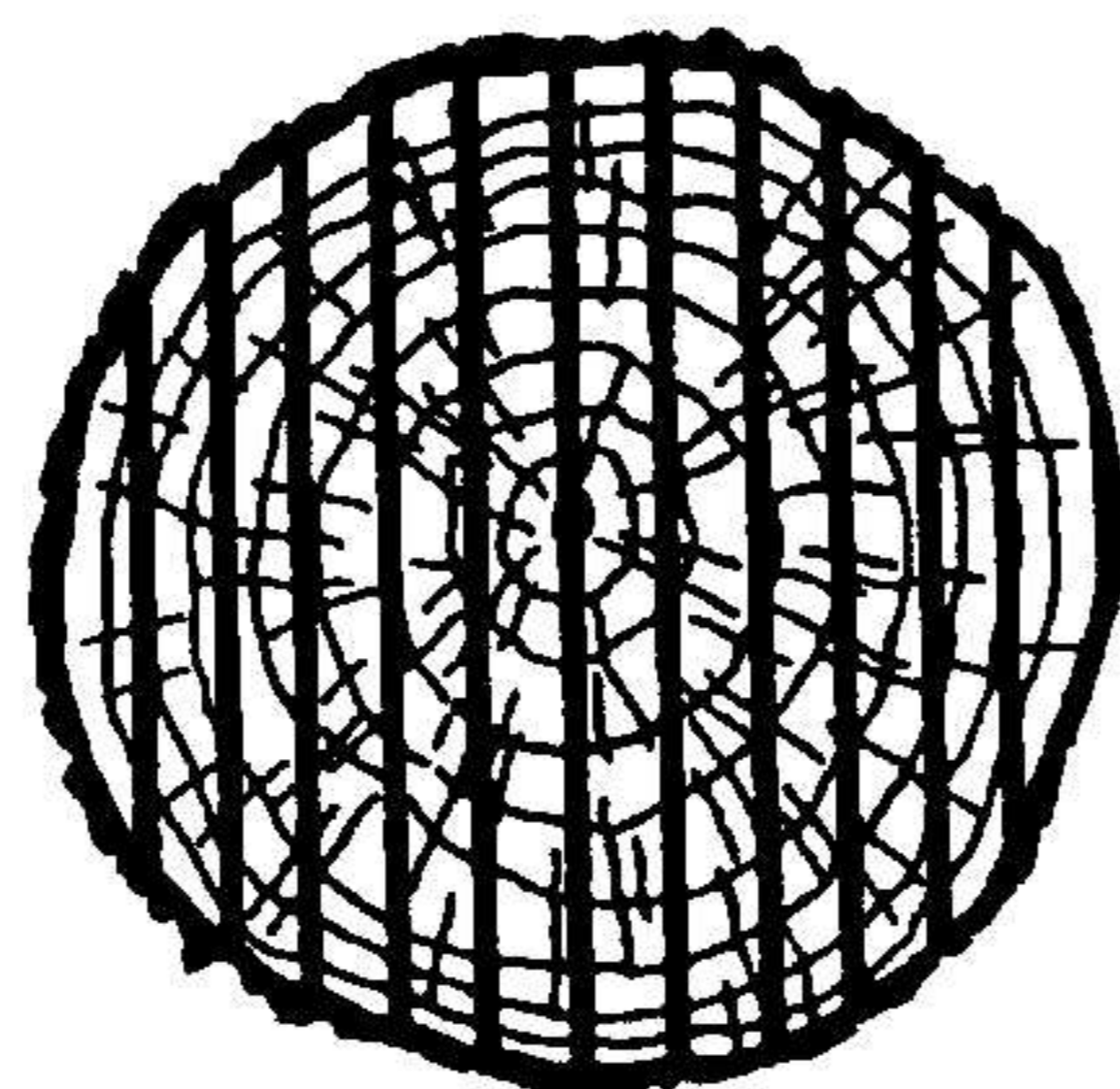

(i) Deursneemetode

(ii) Square-sawn method

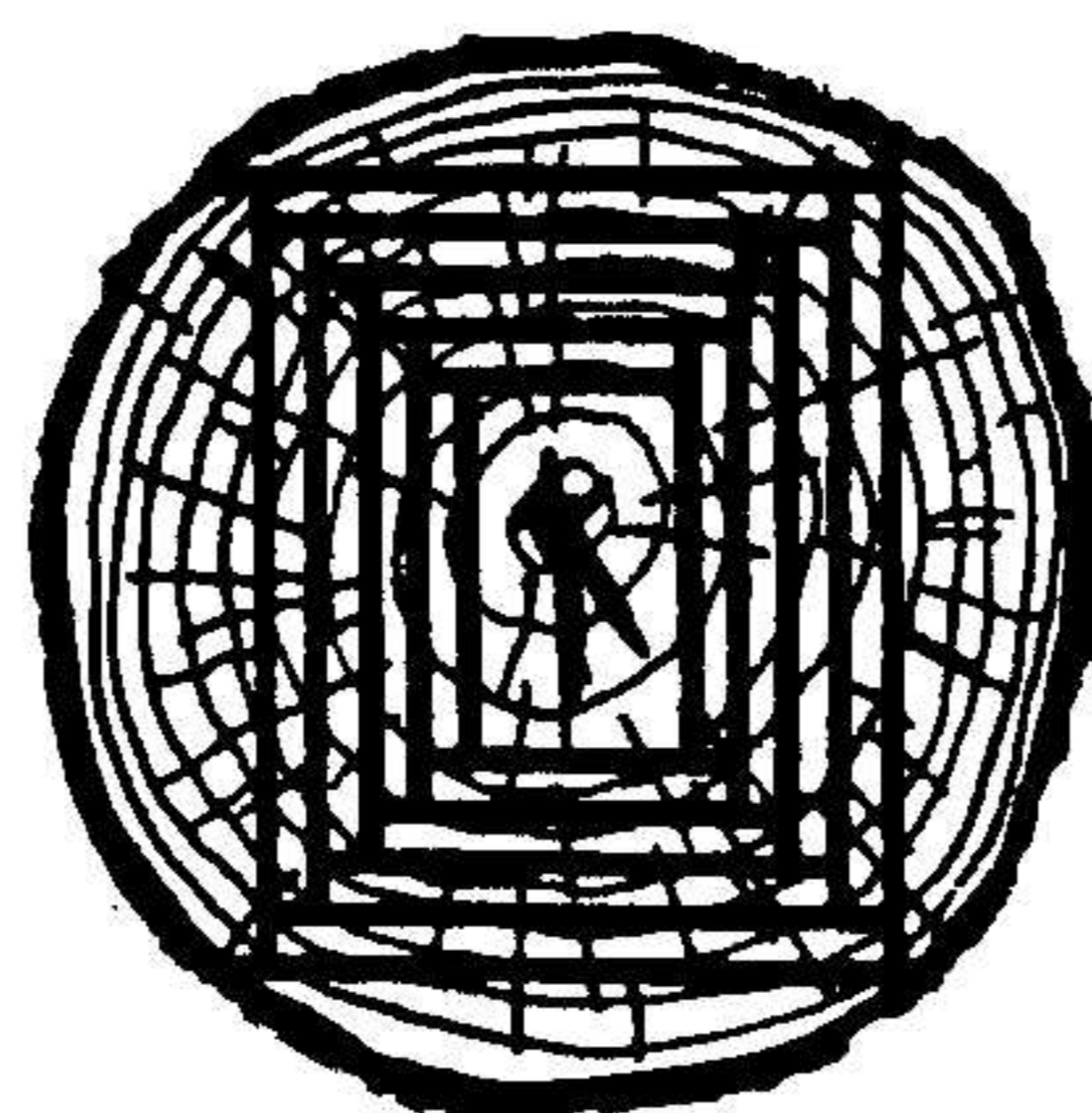

(ii) Vierkant metode

(iii) Quarter-sawn method

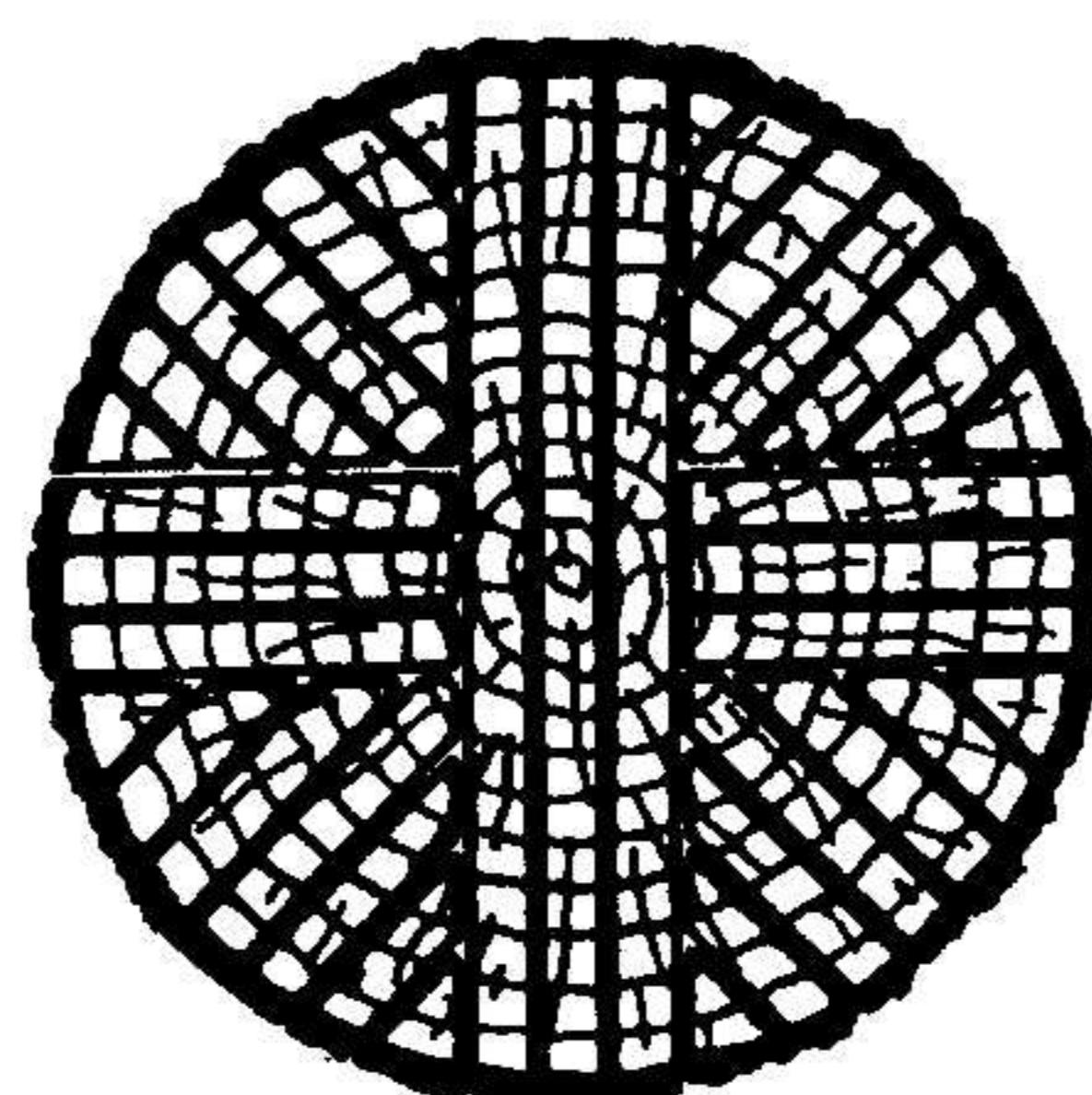

(iii) Kwartsaagmetode

(Any 2)

(Enige 2)

(6)

2.3 (a)  
2.3.1

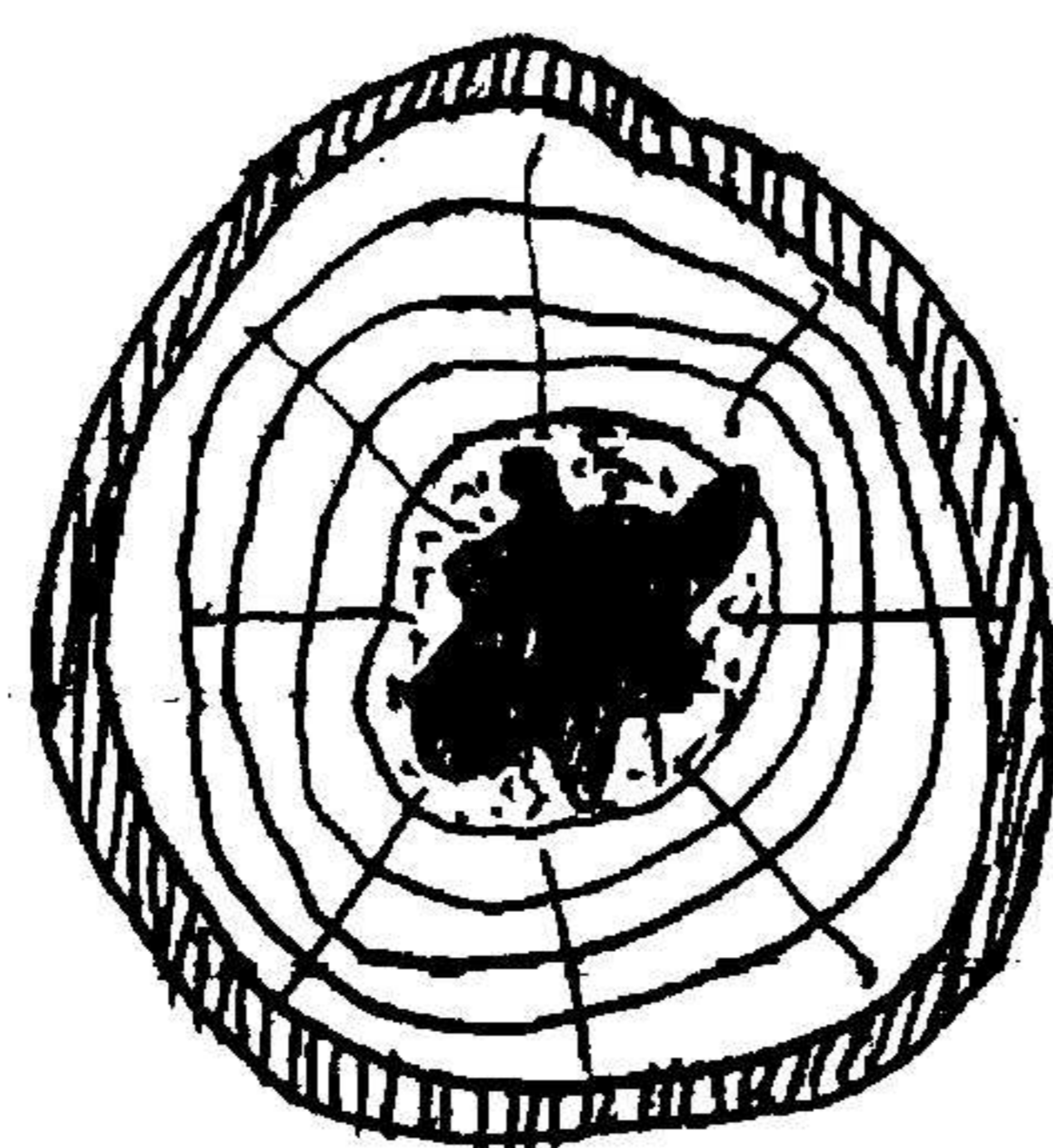

(a)

(b) Shrinkage that starts at the pith, causes cracks collecting water that wets the heartwood excessively. The core becomes spongy and fungi develop.

(b) *Inkrimping wat by die pit begin, veroorsaak openinge waarin water versamel en kernhout oormatig benat. Kern word sponsagtig en swamme ontwikkel.*

(1)

(2)

(c) Tamboti

(c) *Tambotie*

(1)

2.3.2

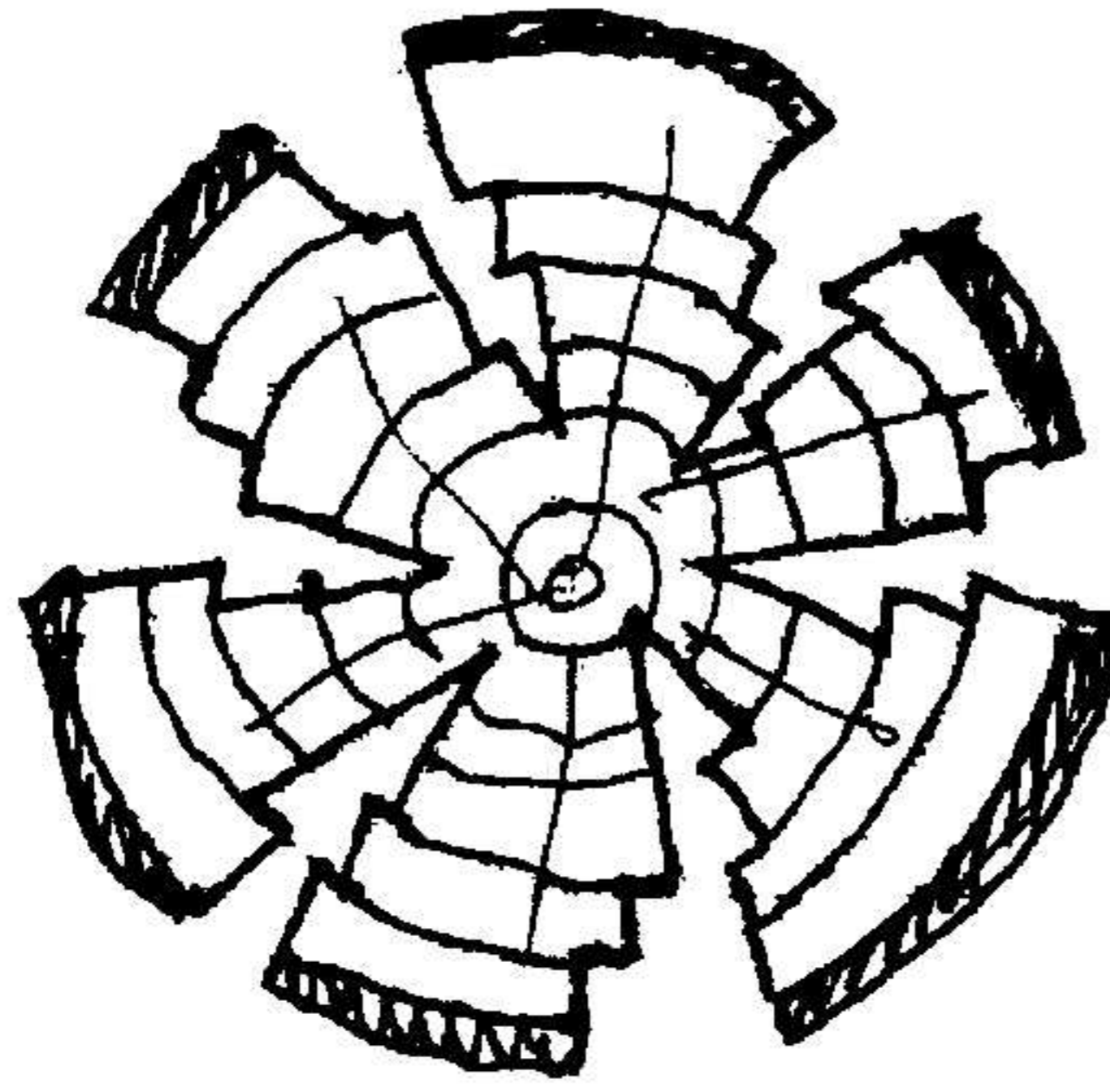

(1)

- 2.3.3
- When sapwood dries quickly and in an uncontrolled manner cracks develop in a radial direction, following the direction of the medullary rays.

- It occurs when logs are not converted into boards and seasoned immediately after felling has taken place.

(Any 1)

- 2.3.3
- *Wanneer saphout vinnig en ongekontroleerd droog, ontwikkel barste in radiale rigting en volg rigting van murgstrale.*

- *Gebeur wanneer blokke nie dadelik wanneer dit gevel is, opgesaag en gedroog word nie.*

(Enige 1) (1)

- 2.3.4
- It refers to boards containing pieces of bark. It occurs when logs are converted too economically.

- 2.3.4
- Planke bevat stukkies bas. Ontstaan wanneer blokke te ekonomies opgesaag word.*

(2)

- 2.3.5
- Causes working problems.
  - Can become loose and fall out.
  - Many knots can reduce the strength of timber

(Any 2)

- 2.3.5
- *Gee gewoonlik bewerkingsprobleme*
  - *Kan los raak en uitval.*
  - *Baie kwaste kan plank verswak.*

(Enige 2) (2)

- 2.4
- It ensures quality
- 2.4.1
- It ensures that the product is suitable for the purpose for which it is required.

- 2.4
- *Dit verseker kwaliteit.*
- 2.4.1
- *Dit verseker dat die produk geskik is vir die doel waarvoor dit benodig word.*

(2)

2.4.2 SABS

2.4.2 SABS

(1)

[40]

## QUESTION 3 / VRAAG 3

- |       |       |   |       |       |   |     |
|-------|-------|---|-------|-------|---|-----|
| 3.1   | (i)   | When rust occurs, use steel wool to polish the metal.   | 3.1   | (i)   | Indien roes voorkom, gebruik staalwol om metaal blink te skuur.   |     |
| 3.1.1 | (ii)  | Apply a thin layer of oil or wax polish.  | 3.1.1 | (ii)  | Wend dun lagie olie of waspolitoer aan.   |     |
|       | (iii) | Should not be placed on top of other tools.   |       | (iii) | Moet nie op ander gereedskap neersit nie.   |     |
|       |       | (Any 2)   |       |       | (Enige 2)   | (2) |
| 3.1.2 | (i)   | Never hit nails, screws, stones, etc. when sawing.  | 3.1.2 | (i)   | Moet nie spykers, skroewe, klippies, ens. raaksaag nie.   |     |
|       | (ii)  | Use the full length of the saw blade in order to utilize all the teeth.   |       | (ii)  | Gebruik die volle lengte van die saag sodat al die tande met die saagaksie gebruik word.  |     |
|       | (iii) | Avoid touching the blade with moist hands.  |       | (iii) | Hou klam hande weg van die lem.   |     |
|       | (iv)  | Use steel wool to remove rust.  |       | (iv)  | Gebruik staalwol om roes te verwyder.   |     |
|       | (v)   | Apply a thin layer of oil or wax polish.  |       | (v)   | Wend dun lagie olie of waspolitoer aan.   |     |
|       |       | (Any 2)   |       |       | (Enige 2)   | (2) |
| 3.1.3 | (i)   | Lubricate sole with a light oilcloth or with wax polish to ease planing.  |       | (i)   | Smeer sool met ligte olielappie of waspolitoer om skaafwerk te vergemaklik.   |     |
|       | (ii)  | Keep the plane clean.   |       | (ii)  | Hou skaaf skoon.  |     |
|       | (iii) | Fasten parts tightly.   |       | (iii) | Draai dele goed vas.  |     |
|       |       | (Any 2)   |       |       | (Enige 2)   | (2) |
| 3.2   | (i)   | Set the pin of the marking gauge as near as possible to the centre line of the rail and prick a hole in the work.           | 3.2   | (i)   | Stel die naald van die kruishout so na as moontlik aan die middellyn van die reling en druk 'n gaatjie.                                   |     |
|       | (ii)  | Turn the work around and make a second mark alongside the other.  |       | (ii)  | Draai die reling om en maak 'n tweede gaatjie langs die eerste.   |     |
|       | (iii) | If they do not correspond exactly, make slight adjustments to the pin until the two marks meet from both sides of the rail. |       | (iii) | Indien die gaatjies nie presies ooreenkom nie moet die kruishout se naald verstel word totdat die twee gaatjies van weerskante ooreenkom. | (3) |
| 3.3   |       |   |       |       |   |     |
| 3.3.1 | B     |   |       |       |   |     |
| 3.3.2 | A     |   |       |       |   |     |
| 3.3.3 | C     |   |       |       |   |     |
| 3.3.4 | A     |   |       |       |   | (4) |

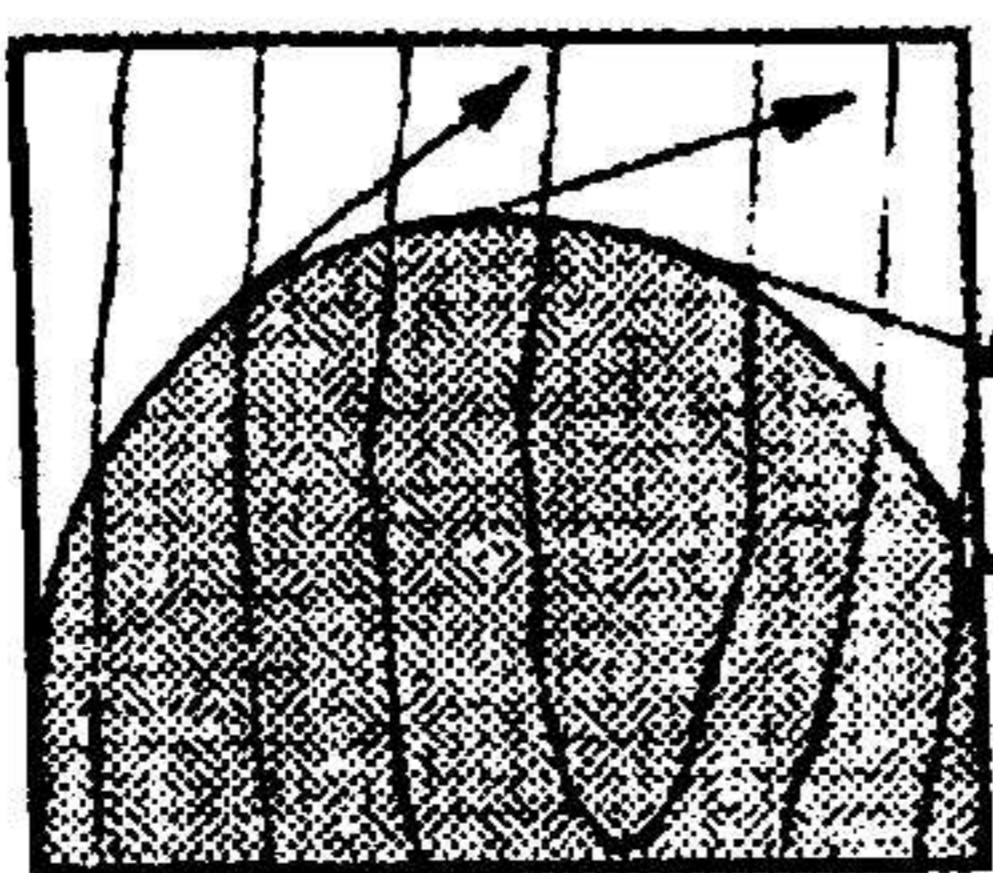
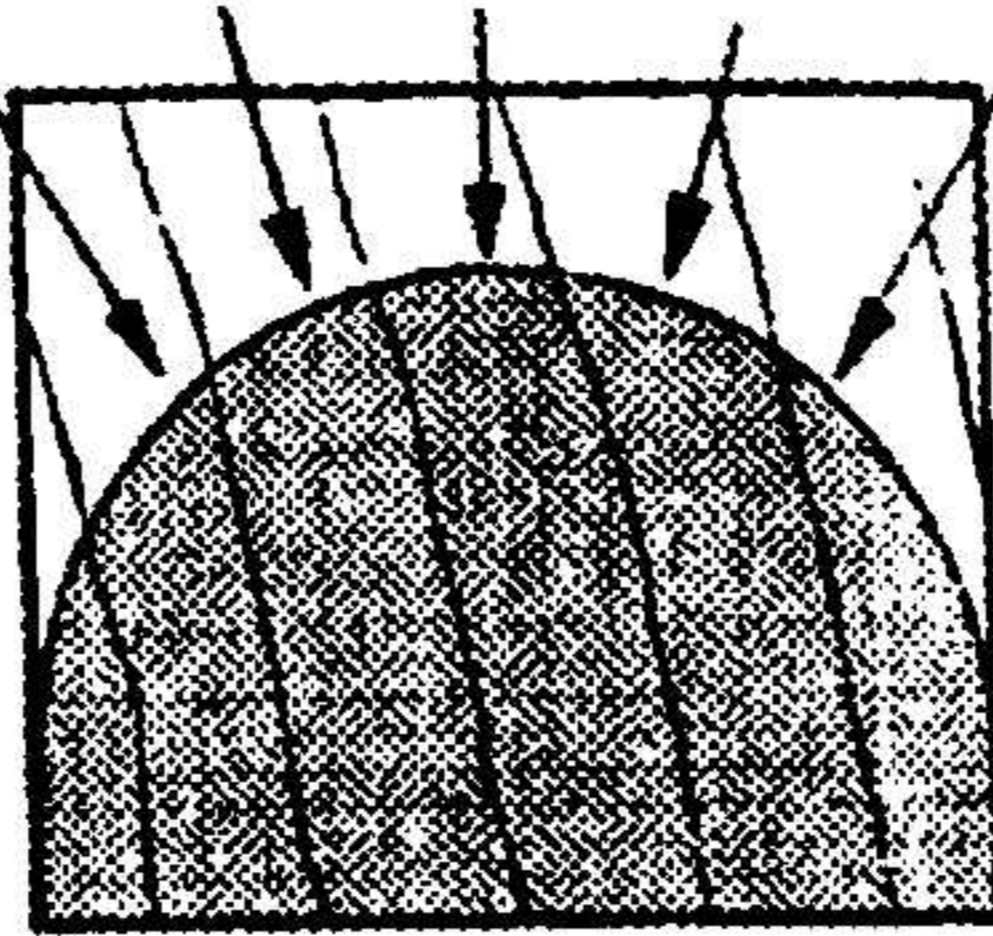
3.4		3.4		
3.4.1	Bench hook	3.4.1	Saagplank	(1)
3.4.2	Back saw / Tenon saw	3.4.2	Rugsaag	(1)
3.4.3	Chiselling or drilling	3.4.3	Beitelwerk of boorwerk	(1)
3.5	(i) Use a try square and draw square lines across the face side and edges.	3.5	(i) Gebruik winkelhaak om haakse lyne oor werksvlak en sykante te trek.	
3.5.1	(ii) Use a marking gauge and draw depth lines on the edges.	3.5.1	(ii) Gebruik enkelpenkruishout om dieptelyne op sykante te trek.	(5)
3.5.2	(i) Use a tenon saw and cut on the waste side of the two face side lines.	3.5.2	(i) Gebruik rugsaag en saag aan afvalkant van twee lengtelyne.	
	(ii) Use a mortice chisel and remove the waste material.		(ii) Gebruik 'n kapbeitel en verwyder afvalmateriaal.	
	(iii) Use a firmer chisel and trim the groove for final fitting.		(iii) Gebruik 'n steekbeitel en rond groef af vir finale passing.	(5)
3.6	(i) Ease the tension of the sanding belt (Tension adjusting arm)	3.6	(i) Verlig spanning van skuurband (spanningverstelarm)	
	(ii) Remove the old belt and replace with new one.		(ii) Verwyder ou band en plaas nuwe band oor trommel.	
	(iii) Put belt under tension (Tension adjusting arm)		(iii) Plaas band onder spanning of trek band styf d.m.v. spanningverstelarm	
	(iv) Switch machine on and adjust the drum to align the sanding belt by using the drum tilting knob.		(iv) Skakel masjien aan en stel belyning met behulp van tromkantelknop.	(4)
3.7	Radiale snitte		Tangensiale snitte	
	Radial cuts		Tangential cuts	(2)
3.8		3.8		
3.8.1	± 6 mm	3.8.1	± 6 mm	(1)
3.8.2	Splitter	3.8.2	Kloofflem	(2)
3.9	Check the stock in advance for loose knots, small metal parts and sand which can damage the blades.	3.9	Planke word vooraf bekyk vir los kwaste, metaaldeeltjies en klippies wat die lemme kan beskadig.	(2)

3.10	(i)	Keep the board firmly against the fence.	3.10	(i)	<i>Hou plankie stewig teen leiblok.</i>	
3.10.1	(ii)	Use a push block to push the board across the knives.	3.10.1	(ii)	<i>Gebruik stootblok om plankie oor skaaf te stoot.</i>	
	(iii)	Assume a firm and well-balanced stance.		(iii)	<i>Staan in 'n stewige gemaklike posisie.</i>	(3)
3.10.2	(a)	A	3.10.2	(a)	A	(1)
	(b)	Method B could cause the board to tilt. This will cause uneven planing. Splitting occurs easily at A.		(b)	<i>Metode B kan die hout laat kantel wat oneweredige skaafwerk tot gevolg sal hê. Splitsing kom maklik by A voor.</i>	(2)
3.11	(i)	The wood should be more or less square.	3.11	(i)	<i>Die hout moet naastenby vierkantig wees.</i>	
	(ii)	Determine the centres on both ends of the wood.		(ii)	<i>Bepaal die senters op beide ente van die hout.</i>	
	(iii)	Drill small holes for the tail stock centre.		(iii)	<i>Boor gaatjies vir loskopsenter.</i>	
	(iv)	Make notches for the spur centre.		(iv)	<i>Maak kepe vir die vurksenter.</i>	(4)
3.12			3.12			
3.12.1		Portable belt sander	3.12.1		<i>Draagbare bandskuurmasjien.</i>	(1)
3.12.2		Move the machine back and forth, as well as sideways over the surface that must be sanded.	3.12.2		<i>Beweeg die masjien vorentoe en agtertoe, asook sywaarts oor die oppervlak wat geskuur moet word.</i>	(2)

[50]

## QUESTION 4 / VRAAG 4

4.1			4.1			
4.1.1		Mitre joint	4.1.1		<i>Verstekvoeg</i>	(1)
4.1.2		Mortice and tenon joint	4.1.2		<i>Tap-en-gatvoeg</i>	(1)
4.1.3			4.1.3			

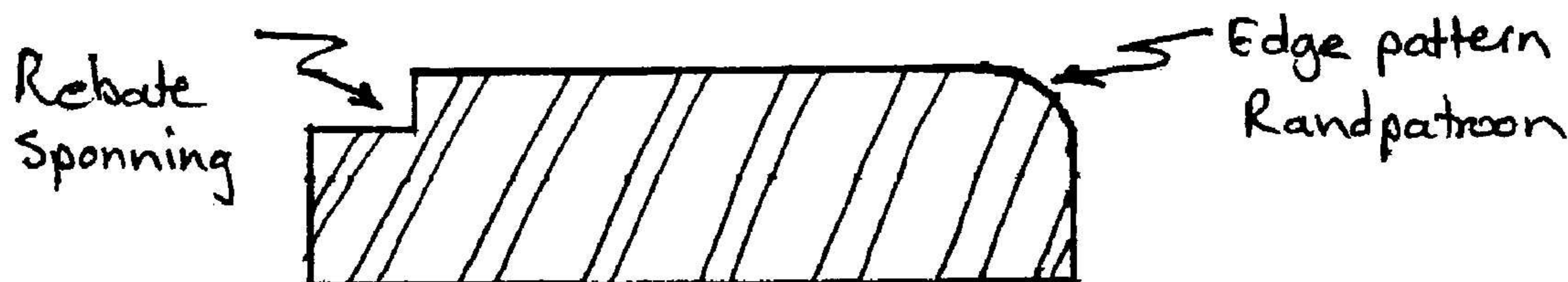

(2)

4.1.4

4.1.4

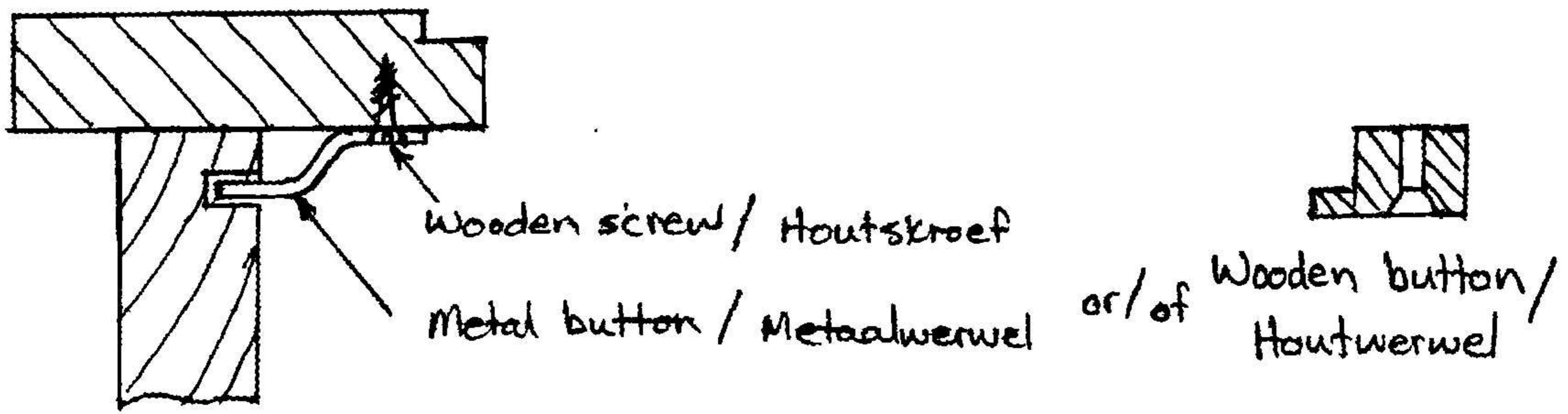

(3)

4.2  
4.2.1

- A Leg
- B Top rail
- C Drawer rail
- D Side rail

4.2  
4.2.1

- A Poot
- B Bo-reling / Boonste laaireling
- C Dra-reling / Onderste laaireling
- D Kantreling / Sykant

(4)

4.2.2

- (a) Dovetail joint
- (b) Mortice and tenon joint
- (c) Haunched double mortice and tenon joint

4.2.2

- (a) Swaelstertvoeg
- (b) Tap-en-gatvoeg
- (c) Dubbeltap-en-gatvoeg met skof

(3)

4.2.3

4.2.3

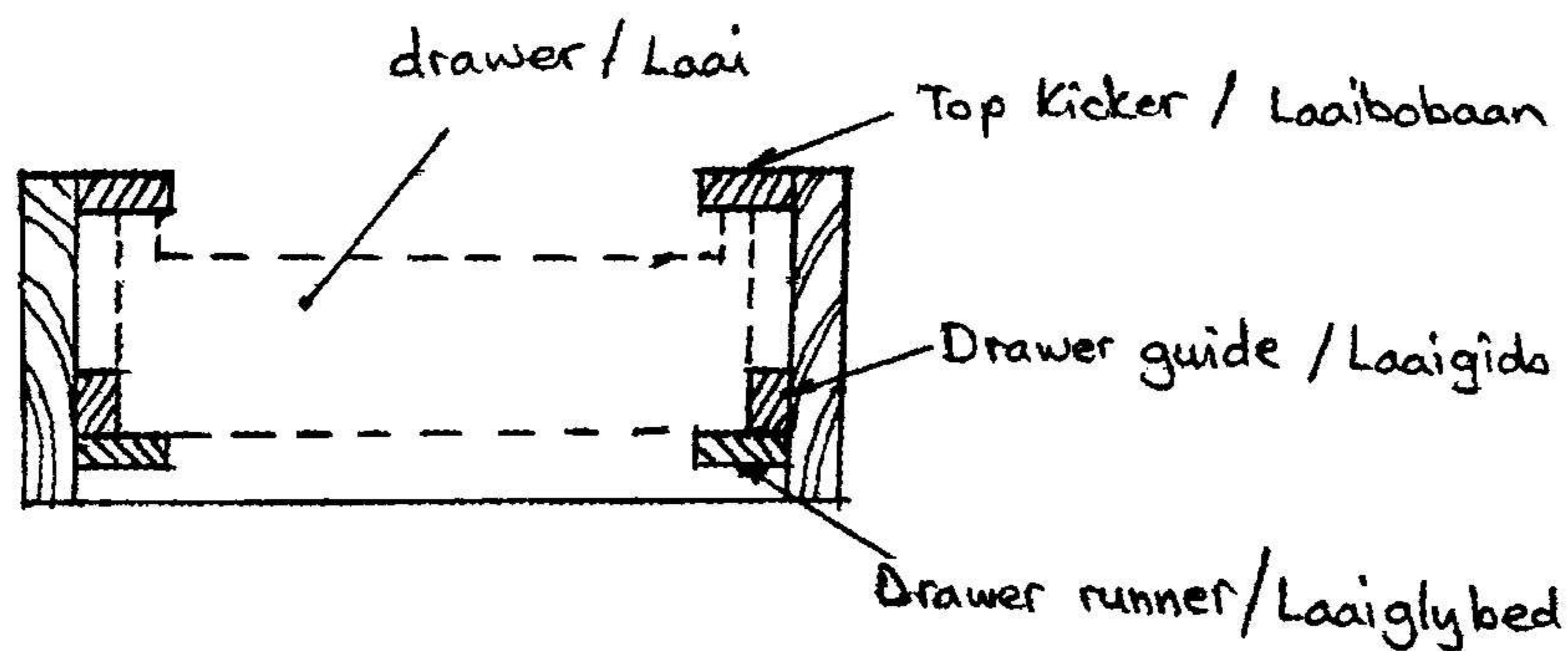

(4)

4.3  
4.3.1

- A Tongue and groove joint
- B Through dovetail housing joint or Tapered dovetail housing joint
- C Rebate joint
- D Through housing joint
- E Box pin joint / finger joint
- F Butt joint

4.3  
4.3.1

- A Tong-en-groefvoeg
- B Deurlopende swaelstert-inlaatvoeg of Tapslopende swaelstert-inlaatvoeg
- C Sponningvoeg
- D Deurlopende inlaatvoeg
- E Ratvoeg / Vingervoeg
- F Stuikvoeg

(6)

4.3.2	(i) Panel pins (ii) Screws (iii) Dowels (iv) Biscuits	(Any 2)	4.3.2	(i) <i>Paneelspykers</i> (ii) <i>Skroewe</i> (iii) <i>Houtpenne</i> (iv) <i>Koekies</i>	(Enige 2)	(2)
-------	--	---------	-------	--	-----------	-----

4.3.3	(i) Panel pins (ii) Screws (iii) Biscuits (iv) Feather and groove	(Any 2)	4.3.3	(i) <i>Paneelspykers</i> (ii) <i>Skroewe</i> (iii) <i>Koekies</i> (iv) <i>Veer-en-groef</i>	(Enige 2)	(2)
-------	--	---------	-------	--	-----------	-----

4.4  
4.4.1

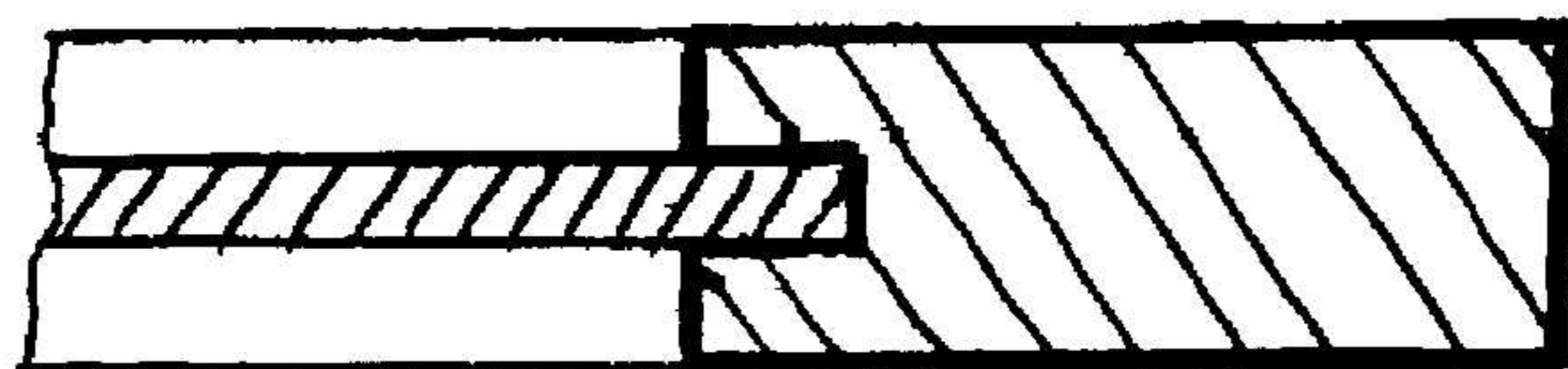

Panel / Paneel  
Frame / Raam

(3)

4.4.2	Haunched mortice and tenon joint	4.4.2	<i>Skof-tap-en-gatvoeg</i>	(1)
4.4.3	No	4.4.3	<i>Nee</i>	(1)
4.4.4	To make provision for expansion and shrinkage the panel should fit loosely.	4.4.4	<i>Die paneel moet los in die groef pas om voorsiening te maak vir uitsetting en inkrimping.</i>	(2)
4.5 4.5.1	(i) Surfaces must fit properly (ii) Dust and shavings must be removed.	4.5 4.5.1	(i) <i>Vlakke moet behoorlik pas.</i> (ii) <i>Stof en saagsels moet verwyder word.</i>	(2)
4.5.2	(i) Apply to both surfaces. (ii) Even and not too thick.	4.5.2	(i) <i>Wend aan op albei oppervlaktes.</i> (ii) <i>Egalig en nie te dik nie.</i>	(1)
4.5.3	(i) Distribute glue evenly and force air bubbles out. (ii) Force glue into pores of wood	4.5.3	(i) <i>Versprei lym egalig en pers lugblasies uit.</i> (ii) <i>Forseer lym in porieë van hout</i>	(2)

[40]



## QUESTION 5 / VRAAG 5

5.1	(i) Enough moisture	5.1	(i) Genoeg vogtigheid	
5.1.1	(ii) Enough oxygen	5.1.1	(ii) Genoeg suurstof	
	(iii) Suitable temperature		(iii) Geskikte temperatuur	
	(iv) Suitable food		(iv) Geskikte voedsel	
	(v) Absence of toxic chemicals		(v) Afwesigheid van toksiese chemikalieë	
	(Any 3)		(Enige 3)	(3)
5.1.2	(i) Discolouration	5.1.2	(i) Verkleuring	
	(ii) Rot		(ii) Verrotting	(2)
5.1.3	(i) Termites	5.1.3	(i) Termiete	
	(ii) Beetles		(ii) Kewers	(2)
5.1.4	Coal tar Creosotes or solutions in volatile organic solvents	5.1.4	Koolteerkreosote of oplossings in vlugtige organiese oplosmiddels.	(1)
5.1.5	(i) The type of timber	5.1.5	(i) Die soort hout	
	(ii) The final uses of the timber		(ii) Waarvoor die hout gebruik sal word	(2)
5.2		5.2		
5.2.1	Clean the wood with turpentine or methylated spirits.	5.2.1	Was die hout met terpentyn of brandspiritus.	
5.2.2	Use a stain.	5.2.2	Behandel met 'n beitsmiddel.	
5.2.3	Use a grain filler.	5.2.3	Gebruik 'n greinvuller.	
5.2.4	Use a sanding block or portable sander.	5.2.4	Gebruik 'n skuurblokkie of draagbare skuurmasjien	
5.2.5	Sand in the direction of the grain.	5.2.5	Skuur in die rigting van die grein.	(5)
5.2.6	220	5.2.6	220	
5.2.7	40 / 80	5.2.7	40 / 80	
5.2.8	600	5.2.8	600	(3)
5.3		5.3		
5.3.1	wax polish or oil polish or varnish	5.3.1	waspolitoer of oliepolitoer of vernis	(1)
5.3.2	Depends on answer given in Question 5.3.1	5.3.2	Hang af van antwoord op 5.3.1	(1)

5.4  
5.4.1

5.4  
5.4.1

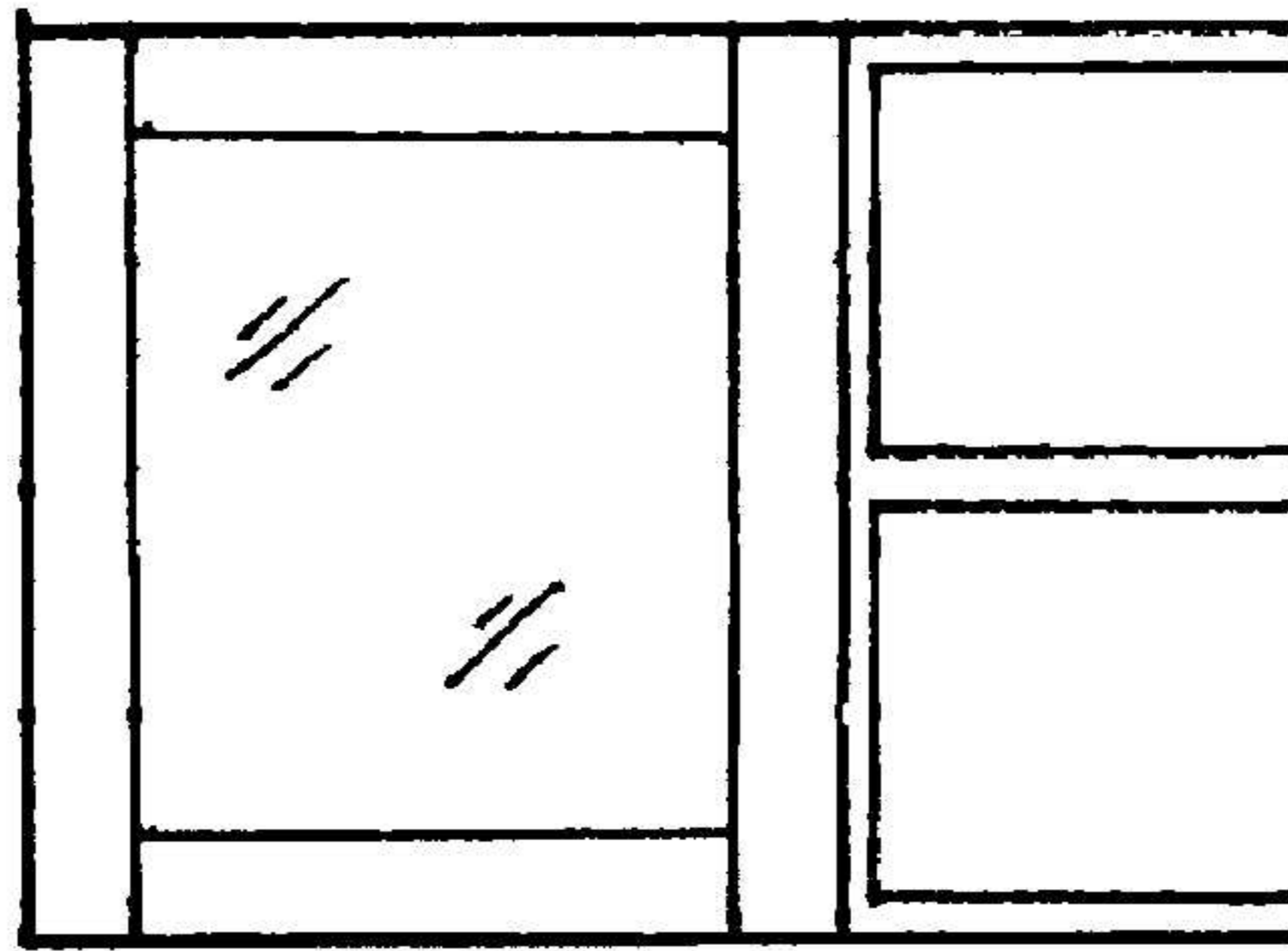

(6)

5.4.2 Any logical answer is correct  
e.g. metal brackets and screws.

5.4.2 *Enige logiese antwoord is korrek  
bv. metaalhakies en skroewe*

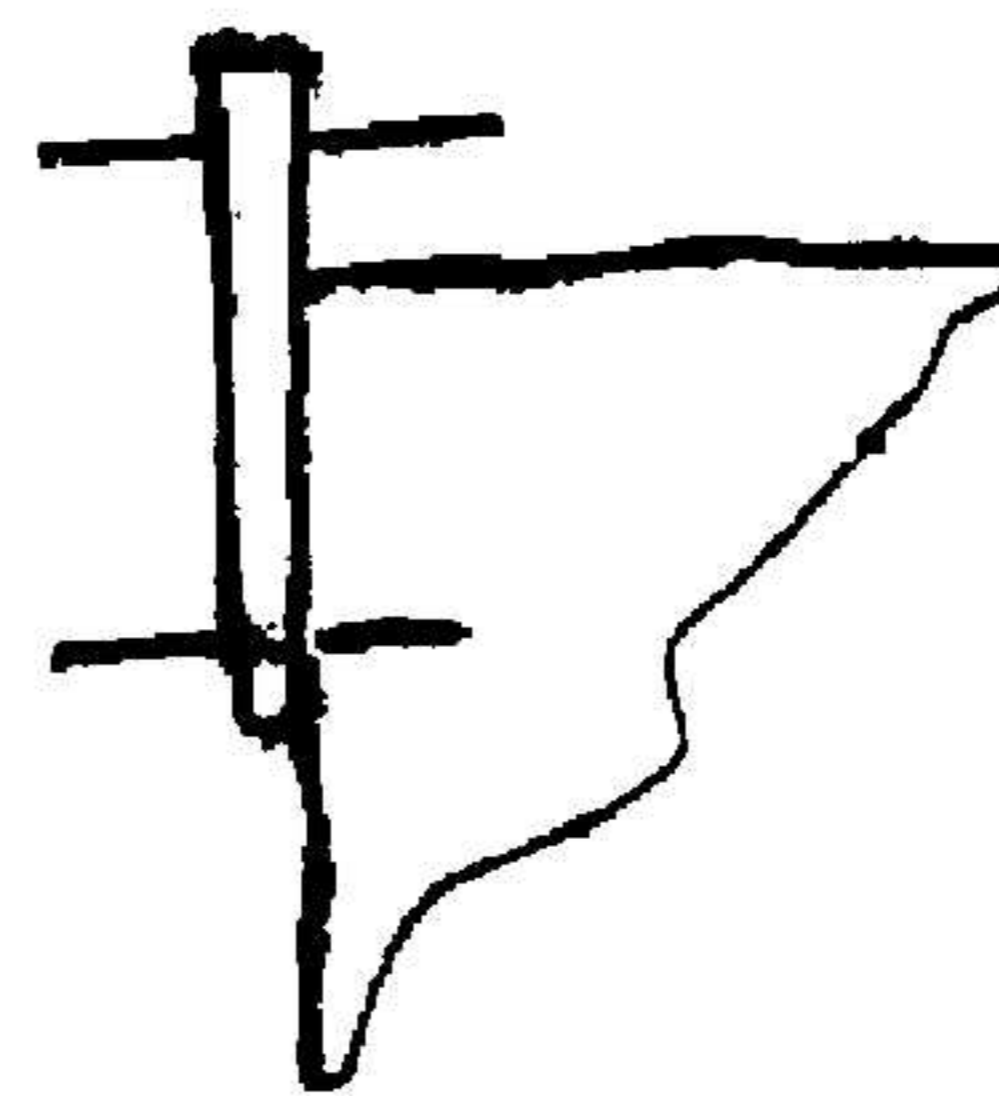
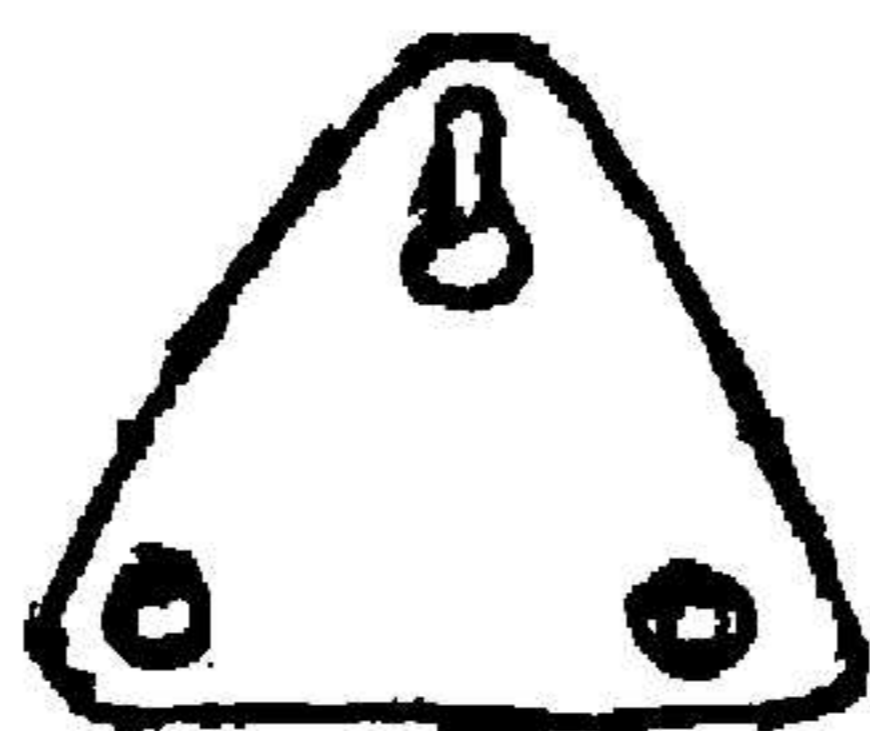

(2)

5.4.3 The stretch distance of the  
average human

5.4.3 *Die reikafstand van die gemiddelde  
mens*

(2)

5.4.4 (i) Functionality  
(ii) Appearance  
(iii) Materials  
(iv) Construction

5.4.4 (i) *Funksionaliteit*  
(ii) *Voorkoms*  
(iii) *Materiaal*  
(iv) *Konstruksie*

(4)

5.5  
5.5.1 Stinkwood and yellowwood

5.5  
5.5.1 *Stinkhout en geelhout*

(2)

5.5.2 (i) Copied existing furniture  
styles  
(ii) Mixing of existing styles  
  
(iii) Non-gilded brass escutcheon  
(iv) Solid wood  
(v) Clumsy and heavy  
(vi) Useful rather than attractive  
(vii) Fit in with local styles of  
building  
(viii) The use of riempies  
(ix) Dismantling of larger furniture  
  
(x) Casters under heavy furniture

5.5.2 (i) *Nagebootste bestaande  
meubelstyle*  
(ii) *Vermenging van bestaande  
style*  
(iii) *Onvergulde koperbeslag*  
(iv) *Soliede hout*  
(v) *Lomp en swaar*  
(vi) *Eerder bruikbaar as aantreklik*  
(vii) *Pas by plaaslike boustyle*  
  
(viii) *Die gebruik van riempies*  
(ix) *Uitmekaarhaal van groter  
meubels*  
(x) *Wieletjies onder swaar meubels  
se pote*

(Any 4)

(Enige 4) (4)

[40]

TOTAL / TOTAAL: 200÷2=100