

**GAUTENG DEPARTMENT OF EDUCATION
GAUTENGSE DEPARTEMENT VAN ONDERWYS
SENIOR CERTIFICATE EXAMINATION
SENIORSERTIFIKAAT-EKSAMEN**

**TECHNIKA (MECHANICAL) HG
TECHNIKA (MEGANES) HG**

POSSIBLE ANSWERS OCT / NOV 2006

QUESTION / VRAAG 1

1.1

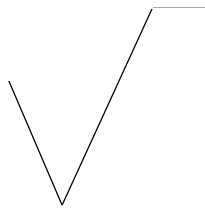

No material removal
Geen materiaalverwydering nie

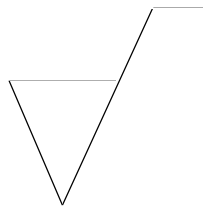

Material removal
Materiaalverwydering

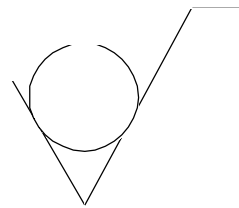

No secondary processes
Geen sekondêre prosesse nie

(9)

1.2

Power = the rate at which work is done

Drywing = die tempo waarteen arbeid verrig word

(2)

1.3

45H9 – d10

	Hole / Gat	Shaft / As
High / Hoë	$45 + 0,062$ = 45,062 mm	$45 - 0,08$ = 44,92
Low / Lae	$45 + 0$ = 45,00 mm	$45 - 0,180$ 44,82 mm

(4)

Clearance fit / *Vry passing*

(2)

1.4

Causes of band slippage

- Load is too heavy for width of belt
- Slack belts
- Oil on belts
- Contact angle too small
- Not enough belts on V-pulleys to transmit power

Oorsake van bandglip:

- *Die vrag is te swaar vir die bandwydte.*
- *Slap bande*
- *Olie op die bande*
- *Kontakhoek te klein*
- *Nie genoeg bande op V-katrolle om drywing oor te dra nie*

(5)

1.5



$$1.5.1 \quad \frac{v^2 - u^2}{2S} = a \quad \frac{0^2 - 21^2}{2(60)} = 60 = \frac{-441}{120} = -3,675 \text{ m/s}^2 \quad (4)$$

$$1.5.2 \quad \begin{aligned} F_{\mu} &= ma \\ &= 200 \times 3,675 \\ &= 735 \text{ N} \end{aligned} \quad (3)$$

$$1.5.3 \quad \begin{aligned} u + at &= v \\ 21 + (-3,675)t &= 0 \\ -3,675 t &= -21 \\ t &= \frac{-21}{-3,675} \\ t &= 5,714 \text{ s} \end{aligned} \quad (4)$$

1.6

$$1.6.1 \quad \begin{aligned} \text{Indexing} &= 40 = 40 = 4 (x6) = 24 \text{ holes on a 66 hole circle} \\ \text{Indeksring} &= \frac{A}{N} = \frac{40}{110} = \frac{4 (x6)}{11 \times 6} = \frac{24 \text{ gate op 'n 66 - gat - sirkel}}{110} \end{aligned} \quad (2)$$

$$1.6.2 \quad \begin{aligned} \text{Change gears} & \quad \text{Driver/Drywer} = \frac{(A - N) \times 40}{N} \\ \text{Wisselratte} & \quad \text{Driven/Gedrewe} \\ &= \frac{(110 - 106) \times 40}{110} \\ &= \frac{16}{11} \\ &= \frac{48}{44} \end{aligned} \quad (5)$$

1.6.3 Direction of rotation is positive / Draairigting is positief (2)

1.6.4

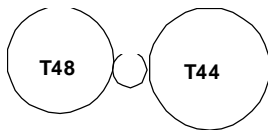

(4)

1.7

Boyle's Law

The volume of a given mass of gas is inversely proportional to the pressure that is exerted on it, if the temperature stays constant.

Die Wet van Boyle

Die volume van ? gegewe gasmassa is omgekeerd eweredig aan die druk wat daarop uitgeoefen word indien die temperatuur konstant bly.

(4)
[50]

QUESTION / VRAAG 2

2.1

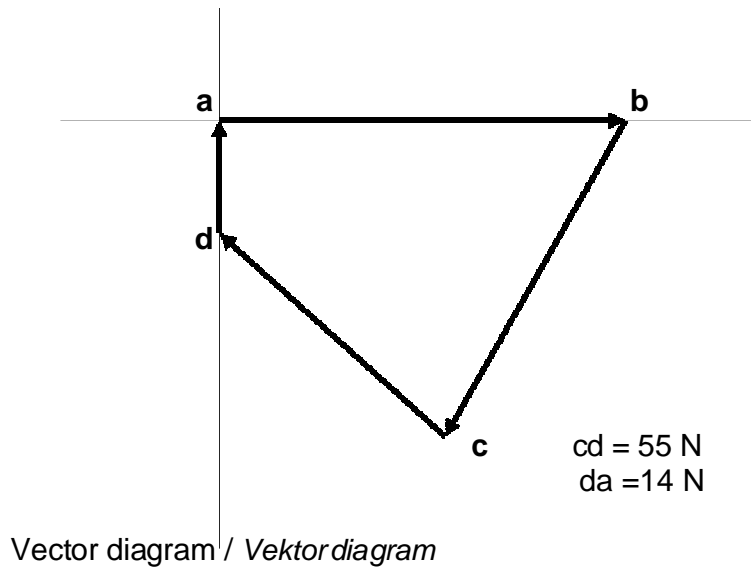
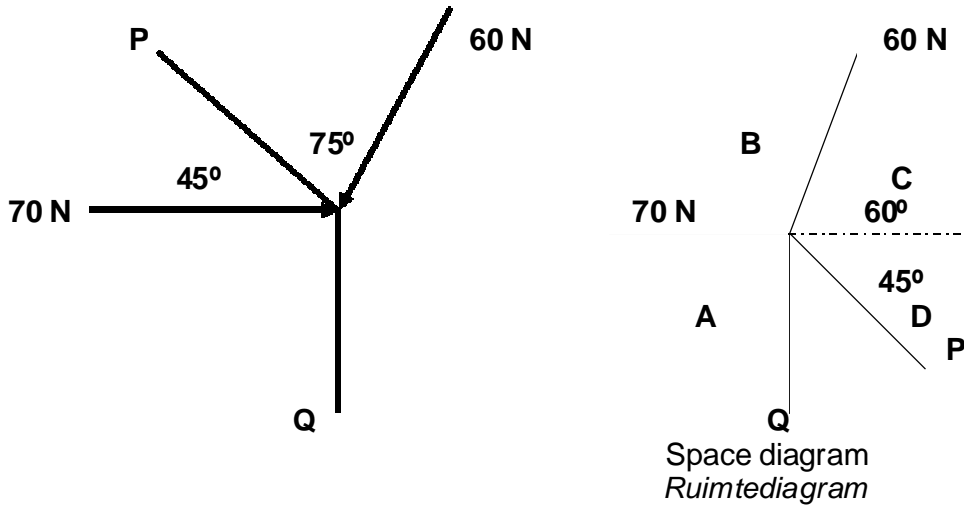

(10)

2.2

Vector: It is a physical quantity with both magnitude and direction.

Vektor: Dit is ? fisiese eenheid wat beide grootte en rigting besit.

(2)

2.3

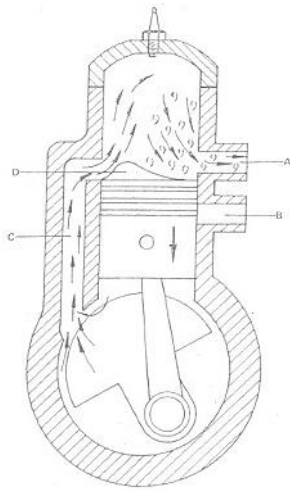

Two stroke engine (SI) / Tweeslag-enjin (v.o)

(2)

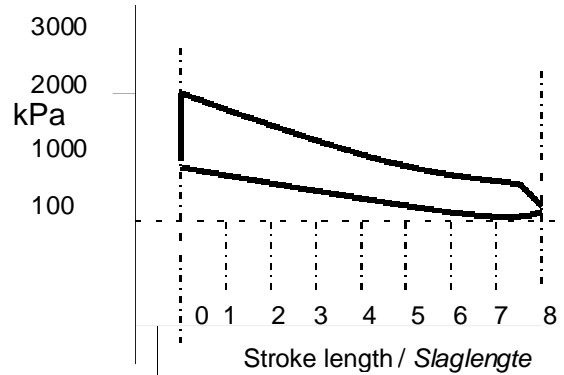

Free space / Vryruimte

(6)

2.4

2.4.1

Indicated power

Indicated power is the theoretical or calculated power that the engine should generate without considering any mechanical or other losses.

Aangeduide drywing

Dit is die teoretiese drywing wat binne die silinder van ? binnebrandenjin ontwikkel word sonder inagneming van enige verliese.

(4)

2.4.2

M.E.P.

The mean effective pressure is the mean positive pressure exerted on the piston during one cycle, taking negative pressure into account.

G.E.D.

Dit is die gemiddelde positiewe druk wat tydens een siklus op die suier uitgeoefen word, met inagneming van negatiewe druk.

(3)

2.5

$$IP / RD = 2pFRn$$

$$FR = 250 \text{ Nm}$$

$$= 2p \cdot 250 \times \frac{2800}{60}$$

$$= 73,3 \text{ kW}$$

(4)

2.6 Reduction gear ratio

The planet carrier will be coupled to the output shaft. One of the other two components is held or locked and the third is driven. Reduction is caused at the planet carrier.

Ratreduksie

Die planeetraam word aan die uitset-as gekoppel. Een van die ander twee komponente word gesluit en die derde word aangedryf. Reduksie ontstaan by die planeetraam.

(4)

Overdrive ratio

When the planet carrier is driven while one of the other two components is locked, the third member will be driven at an increased speed.

Snelgang

Wanneer die planeetraam aangedryf word terwyl een van die ander twee komponente gesluit word, sal ? snelgang of spoedverhoging by die derde komponent ontstaan.

(4)

2.7 Industrial housekeeping means a place for everything and everything in its place for the following reasons:

Saves time
Space is saved
Injuries are avoided
Reduced fire hazards

Bedryfshuishouding beteken ? plek vir alles en alles op hul plek en is noodsaaklik om die volgende redes.

*Bespaar tyd
Bespaar ruimte
Voorkom beserings
Verminder brandgevaar*

(5)

2.8 Carbon and hydrogen eagerly bind with oxygen from the atmosphere. The end products are carbon dioxide and water. Large quantities of energy are released in the form of heat and light.

Octane petrol + oxygen → carbon dioxide + water + energy
 $C_8H_{18} + O \rightarrow CO_2 + H_2O + \text{Energy}$

Koolstof en waterstof verbind graag met suurstof vanuit die lug. Die eindprodukte is koolstofdiksied en water. Groot hoeveelhede energie in die vorm van warmte en lig word vrygestel.

Oktaanpetrol + Suurstof → Koolstofdiksied + Water + Energie
 $C_8H_{18} + O \rightarrow CO_2 + H_2O + \text{Energie}$

(6)

QUESTION / VRAAG 3

3.1

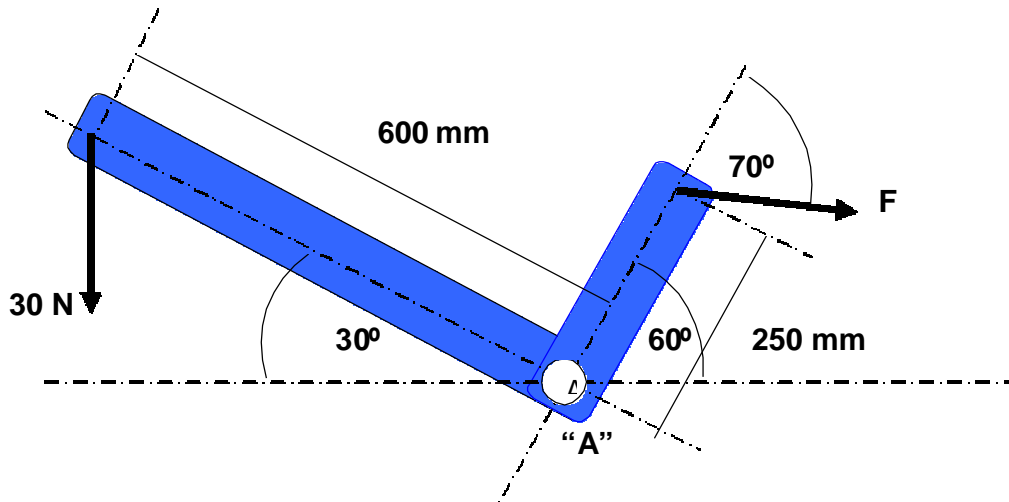

(16)

Take moments about A / *Neem momente om A*

$$\begin{aligned}\sum LHM &= \sum RH \\ (30 \cos 30 \times 600) &= (F \cos 20 \times 250) \\ 15\,588,457 &= F234,923 \\ 66,35 \text{ N} &= F\end{aligned}$$

Take the sum of the VC = 0 / *Stel die som van die VK = 0*

$$\begin{aligned}Y - 30 - 66,35 \sin 10^\circ &= 0 \\ Y - 30 - 11,52 &= 0 \\ My &= 41,52 \text{ N}\end{aligned}$$

Take the sum of the HC = 0 / *Stel die som van die HK = 0*

$$\begin{aligned}X + 66,35 \cos 10^\circ &= 0 \\ X &= -65,34\end{aligned}$$

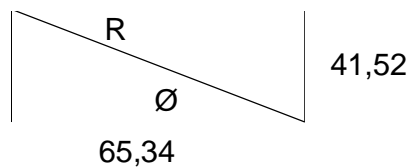

$$\begin{aligned}R &= \sqrt{(41,52)^2 + (65,34)^2} \\ &= \sqrt{1\,723,9 + 4\,269,576} \\ &= 77,417 \text{ N}\end{aligned}$$

$$\begin{aligned}\tan \emptyset &= \frac{41,52}{65,34} \\ &= 0,6354 \\ \emptyset &= 32,43^\circ\end{aligned}$$

$$\boxed{R\ 77,417\ \text{N}\ W\ 32,43^\circ\ \text{N}}$$

- 3.2 Young's modulus of elasticity (E)
 Because strain is proportional to the stress which produces it, thus:

$$\frac{\text{Stress}}{\text{Strain}} = \text{a constant for each type of material.}$$
 This constant is called Young's modulus of elasticity and thus:
 Young's modulus of elasticity, $E = \frac{\text{Stress}}{\text{Strain}}$

Young se elastisiteitsmodulus (E)
Aangesien vormverandering ewere dig is met die spanning wat dit veroorsaak, is:

Spanning
Vormverandering = ? konstante vir elke tipe materiaal. Hierdie konstante word Young se elastisiteitsmodulus genoem en dus

Young se elastisiteitsmodulus, $E = \frac{\text{Spanning}}{\text{Vormverandering}}$ (4)

- 3.3 Stress-strain graph for mild steel / *Spanning-vormveranderingsgrafiek vir sagte staal*

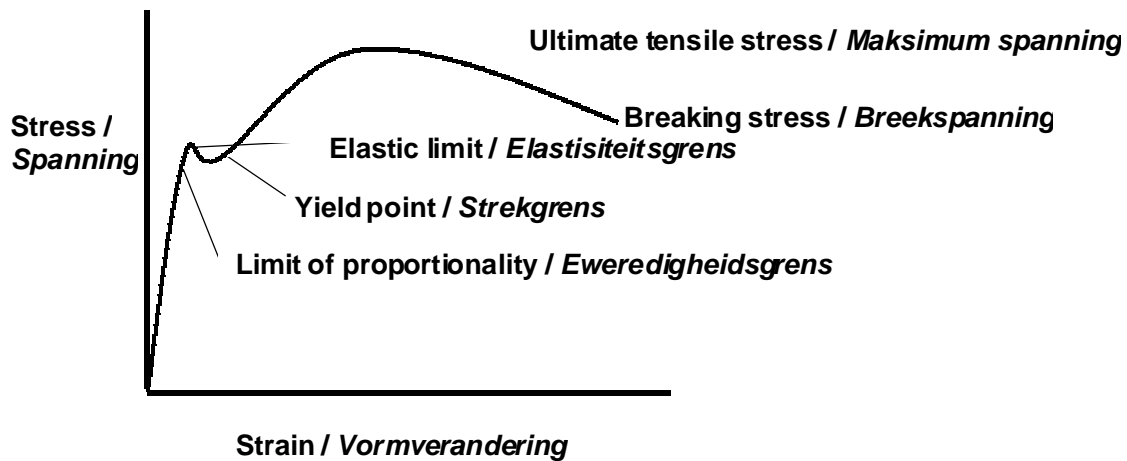

- 3.4 (a)
$$\frac{\text{Strain}}{\text{Vormverandering}} = \frac{\text{Change in length/verandering in lengte}}{\text{Original length/Oorspronklike lengte}}$$

$$= \frac{0,124}{2\,000} = 0,000062 \quad (3)$$

(b)
$$\begin{aligned} \text{Stress} &= E \times \text{strain} \\ \text{Spanning} &= E \times \text{vormverandering} \\ &= 70\,000 \times 10^6 \times 0,000062 \\ &= 4,34 \text{ MPa} \end{aligned} \quad (4)$$

$$(c) \quad F \text{ force} = \text{Stress} \times \text{Area}$$

$$F \text{ (krag)} = \text{Spanning} \times \text{area}$$

$$= 4,34 \times 10^6 \times \pi \times \frac{5 \times 5}{10^6}$$

$$= 340,86 \text{ N}$$

$$= 34 \text{ kg}$$

(4)

- 3.5 For the colour penetrating test, a coloured penetrating liquid is used to test for small cracks in the surface. This will not show cracks underneath the surface. A coloured penetrating liquid is sprayed on the cleaned part that has to be examined and is left to penetrate. The excess is removed with a cleaning agent and the surface is rinsed with water and left to dry. As soon as the surface is dry, developing liquid is sprayed on the surface which then shows the colourant captured in the cracks and holes. As the penetration ability of the coloured liquid differs with the material that has to be tested, as well as the temperature during the process, it is of the utmost importance to allow enough time for the liquid to penetrate. (3 to 60 minutes)

Vir die kleurstofdeurdringingstoets word gekleurde deurdringingsvloeistof gebruik om te toets vir krakies op die oppervlak. Dit sal nie krakies wys wat onder die oppervlak voorkom nie. Die gekleurde deurdringingsvloeistof word op die skoongemaakte gedeelte wat ondersoek moet word, gespuit en toegelaat om in te trek. Nou word die oortollige kleurstof verwyder met ? skoonmaakmiddel, en die oppervlak word gewas met water en toegelaat om droog te word. Sodra die oppervlak droog is, word ontwikkelingsvloeistof op die oppervlak gespuit wat dan die kleurstof wat in die krake en gaatjies vasgevang is na vore bring. Omdat die indringingsvermoë van gekleurde vloeistof verskil volgens die metaal wat getoets moet word, asook die temperatuur tydens die toetsproses, is dit uiters noodsaaklik om voldoende tyd toe te laat vir die vloeistof om in te dring (3 tot 60 minute)

(7)

- 3.6 Isothermal compression

If the volume of an ideal gas decreases at a constant temperature, pressure will increase. This takes place at a constant temperature in accordance with Boyle's Law.

Isotermiese samepersing

Indien die volume van ? ideale gas teen konstante temperatuur verminder, sal die druk toeneem. Dit vind plaas by konstante temperatuur en is in ooreenstemming met die wet van Boyle.

(4)

QUESTION / VRAAG 4

- 4.1 Radian: It is the angle that is formed at the centre of a circle if the radius is marked off on the circumference.

Radiaal: Dit is die hoek wat by die middelpunt van 'n sirkel gevorm word wanneer die radius op die omtrek afgemeet word.

$$1 \text{ Radiaal} = 57,3^\circ \quad (4)$$

- 4.2 There are 2π radians in 1 rev. / Daar is 2π radiale in 1 omwenteling

$$\text{DWS/DI} \quad 2\pi \text{ rad} = 360^\circ$$

$$1 \text{ rad} = \frac{360}{2\pi}$$

$$1 \text{ rad} = 57,3^\circ$$

$$2 \text{ rad} = 57,3^\circ \times 2 = 104,6^\circ \quad (4)$$

- 4.3
4.3.1

$$\begin{aligned} 420 \text{ rpm} &= \frac{2\pi}{60} \times 420 \\ &= 43,98 \text{ rad/s} \end{aligned}$$

$$\begin{aligned} 1\,120 \text{ rpm} &= \frac{2\pi}{60} \times 1\,120 \\ &= 117,29 \text{ rad/s} \end{aligned}$$

$$\alpha = \frac{\omega - \omega_0}{t}$$

$$= \frac{117,29 - 43,98}{12}$$

$$= 6,109 \text{ rad/s}^2 \quad (4)$$

- 4.3.2 $T = mk^2\alpha$

$$= 78 \times 0,302^2 \times 6,109$$

$$= 43,45 \text{ Nm} \quad (4)$$

- 4.3.3 $I = mk^2$

$$= 78 \times 0,302^2$$

$$= 7,11 \text{ kg}\cdot\text{m}^2 \quad (4)$$

- 4.3.4 Kinetic energy $= \frac{1}{2} mk^2\omega^2$

$$\text{Kinetiese energie} = \frac{1}{2} \times 78 \times 0,302^2 \times 117,29^2$$

$$= 48\,932,84 \text{ J}$$

$$= 48,932 \text{ kJ} \quad (5)$$

4.4

4.4.1 $F = mg$

$$F = 3\,000 \times 10$$

$$F = 30\,000 \text{ N}$$

$$W \sin \theta$$

$$30\,000 \sin \frac{1}{30}$$

$$= 1\,000 \text{ N}$$

(4)

4.4.2
$$S = \frac{v^2 - u^2}{2a} = \frac{6^2 - 0^2}{2a} = 600$$

$$a = \frac{36}{2(600)}$$

$$a = 0,03 \text{ m/s}^2$$

(4)

4.4.3 $F = ma$

$$= 3\,000 \times 0,03$$

$$= 90 \text{ N}$$

(3)

4.4.4 $F - F\mu - W \sin \theta = ma$

$$F - 200 - 980 = 3\,000 \times 0,03$$

$$F = 90 + 200 + 980$$

$$F = 1\,270 \text{ N}$$

(4)

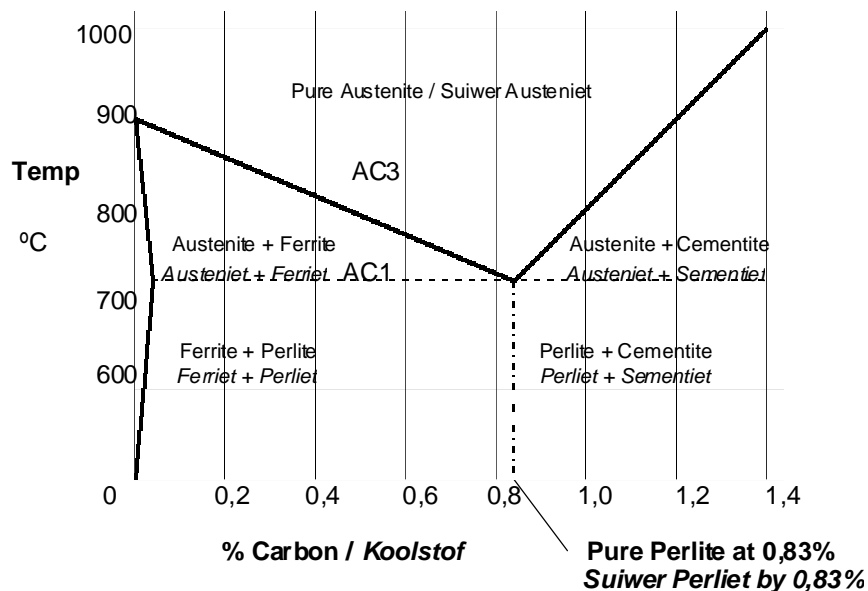
4.5 Iron – Carbon equilibrium diagram / *Yster-koolstof-ewewig-diagram*

(10)

QUESTION / VRAAG 5

5.1

5.1.1

Potential energy:

Potential energy is the energy a body possesses because of gravitation and the relative position of the body to a specific reference plane.

Potensiële energie:

Dit is die energie wat ? voorwerp besit a.g.v. gravitasie en relatiewe posisie t.o.v. die verwysingsvlak.

(4)

5.1.2

Kinetic energy

The energy that a body possesses due to its motion is called kinetic energy.

Kinetiese energie

Dit is die energie wat ? voorwerp besit a.g.v. sy beweging.

(4)

5.2

5.2.1

Indicated Power / Aangeduide Drywing

$$IP / AD = PLAN_N$$

$$IP / AD = 980 \times 10^3 \times 0,11 \times \frac{\rho \times 48 \times 48}{1\,000 \times 1\,000} \times \frac{3\,500 \times 6}{50 \times 2}$$

$$IP / AD = 980 \times 10^3 \times 0,11 \times 0,0072382295 \times 29,16 \times 6$$

$$IP / AD = 136,5 \text{ kW}$$

(7)

5.2.2

Work done for ONE stroke / Arbeid verrig vir EEN slag

$$W = PLA$$

$$W = 980 \times 10^3 \times 0,11 \times \frac{\rho \times 48 \times 48}{1000 \times 1000}$$

$$W = 780,28 \text{ Joule}$$

(3)

5.2.3

Brake Power / Remdrywing

$$BP/RD = 2\pi N T$$

$$\text{Waar } T = FR$$

$$T = 160 \times 1,2$$

$$= 192 \text{ Nm}$$

$$BP/RD = 2 \times \pi \times \frac{3\,500}{60} \times 192$$

$$BP/RD = 70,371 \text{ kW}$$

(4)

$$\begin{aligned}
 5.2.4 \quad MD/ME &= \frac{BP/RD}{IP/AD} \times 100 \\
 &= \frac{70,371}{136,5} \times 100 \\
 &= 51,55 \% \qquad (3)
 \end{aligned}$$

5.3

$$\begin{aligned}
 5.3.1 \quad T &= F \times R \\
 &= 200 \times 0,5 \\
 &= 100 \text{ N.m} \qquad (2)
 \end{aligned}$$

$$5.3.2 \quad 360^\circ = 2\pi \text{ radians / radiale}$$

$$30^\circ = x \text{ radians / radiale}$$

$$x = \frac{2\pi}{360}$$

$$x = \frac{2\pi}{360} \times 30$$

$$= 0,524 \text{ radians / radiale}$$

$$\text{Work} = T \times \theta$$

$$\text{Arbeid} = 100 \times 0,524$$

$$= 52,4 \text{ J}$$

(5)

5.4

$$5.4.1 \quad D_G n_G = D_D n_D$$

$$D_G \times 550 = 0,6 \times 900$$

$$D_G = \frac{0,6 \times 900}{550}$$

$$= 0,98 \text{ m}$$

(4)

5.4.2

$$\frac{T_1}{T_2} = 3$$

$$\therefore T_1 = 3 T_2$$

$$\text{Power} = (T_1 - T_2) \pi D n$$

Drywing

$$9\,000 = (3T_2 - T_2) \pi \times 0,6 \times \frac{900}{60}$$

$$318,31 = 2T_2$$

$$\therefore T_2 = 159,15 \text{ N}$$

$$\text{and / en } T_1 = 477,46 \text{ N}$$

(5)

5.4.3 V.R. $= \frac{n_D}{n_G}$

$$= \frac{900}{500}$$

$$= 1,64 \quad (3)$$

5.5 The services of a social worker can be incorporated for the welfare of an employee and his family. The work of the social worker is to identify personal problems and to advise and help an employee and his family

? Maatskaplike werker / werkster word dikwels aangewend in belang van die werknemer en sy gesin. Die doel van ? maatskaplike werk(s)ter is om persoonlike probleme te identifiseer en om die werker en sy gesin van raad en bystand te bedien. (2)

5.6 Well trained and intelligent
 Have initiative
 Have sound judgment
 Always be fair
 Have healthy human relations

*Goed opgelei en intelligent
 Inisiatief
 Goeie oordeelsvermoë
 Altyd regverdig
 Goeie menseverhoudinge* *Enige VIER* (4)

QUESTION / VRAAG 6

6.1 Disengaging

- The thrust bearing is moved by the operator in the direction of the fly wheel.
- The disengaging lever moving around the support point pulls the pressure plate against the tension of the springs and away from the flywheel.
- The clutch plate is released and is no longer in contact with the flywheel or the pressure plate.
- The lead bearing is in operation and enables the flywheel to rotate around the stationary output axle (clutch plate).

Ontkoppeling

- Die druklaer word deur die operateur in die rigting van die vliegwiel beweeg.
- Die ontkoppelingshafboom wat om die steunpunt beweeg, trek die drukplaat teen die spanning van die vere weg van die vliegwiel.
- Die koppelaarplaat kom vry en is nie langer in aanraking met die vliegwiel of drukplaat nie.
- Die leilaer tree in werking en stel die vliegwiel in staat om rondom die stilstaande uitset-as (koppelaarplaat) te roteer. (9)

6.2

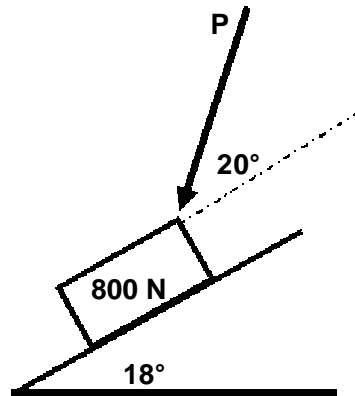

To calculate P / Om P te bereken

$$P \cos 20^\circ + 800 \sin 18^\circ = F \mu$$

$$P \cos 20^\circ = F \mu - 800 \sin 18^\circ$$

$$P \cos 20^\circ = \mu (800 \cos 18^\circ + P \sin 20^\circ) - 800 \sin 18^\circ$$

$$P 0,939 = 0,4 (760,84 + P 0,342) - 247,21$$

$$P 0,939 - P 0,1368 = 304,33 - 247,21$$

$$P 0,802 = 57,12$$

$$P = 71,22 \text{ N} \quad (8)$$

6.3

Welding process

Type of welding rod

Climate

Number of welding runs

Composition of base metal

Die sweisproses

Tipe sweisstafie

Klimaat

Aantal sweislopie

Samstelling van moedermateriaal

(5)

6.4

Bring workpiece in contact with penetrator

Apply primary load

Set meter reading to zero

Apply secondary load

Take final reading

Bring die werkstuk in kontak met die penetreerder

Pas primêre lading toe

Verstel die lesing van die meter na zero

Pas sekondêre lading toe en neem finale lesing

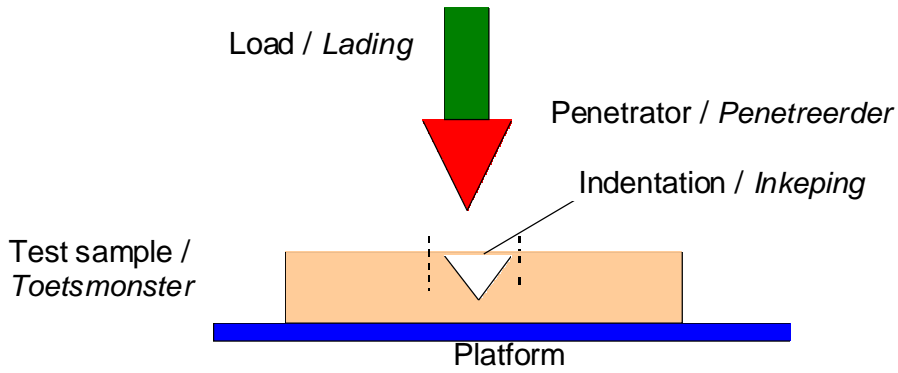

(8)

- 6.5 Low production
Absence from work
Neglected families
Accidents
Unemployment

*Lae produktiwiteit
Baie afwesig van werk
Verwaarloosde huisgesinne
Ongelukke
Werkloosheid*

(4)

6.6

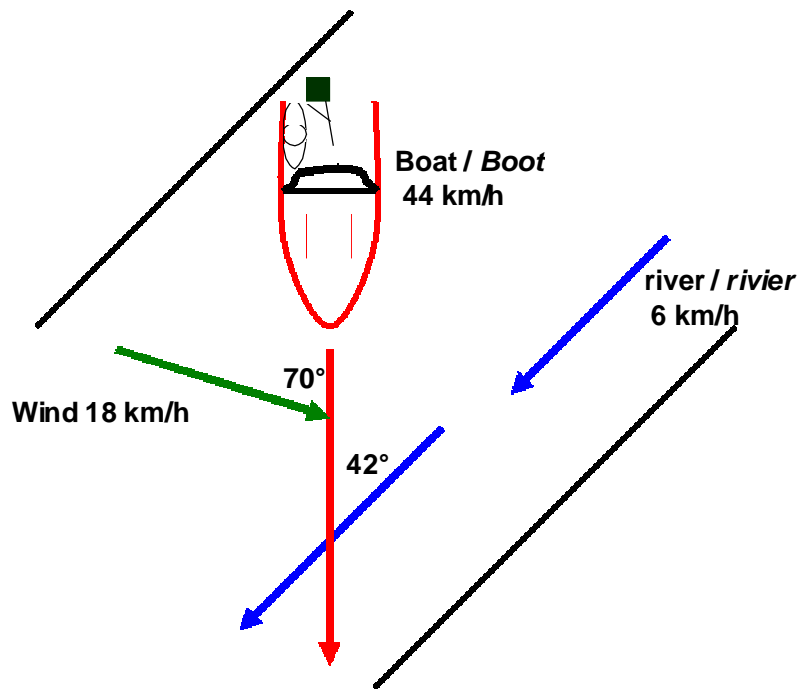

Sum of VC / Som van die VK
 $VC/VK = 44 + 18\sin 20 + 6\sin 48$
 $VC/VK = 44 + 6,156 + 4,46$

$VC/VK = 54,62 \text{ N}$

Sum of HC / Som van die HK
 $HC/HK = 18 \cos 20 - 6 \cos 48$
 $HC/HK = 16,914 - 4,01$
 $HC/HK = 12,931$

$$R = \sqrt{(54,62)^2 + (12,931)^2}$$

$$R = \sqrt{2983,3 + 167,21}$$

$$R = 56,13 \text{ N Suid } 76,68^\circ \text{ Oos}$$

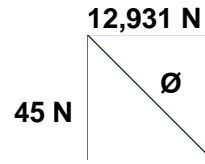

$$\tan \emptyset = \frac{12,931}{54,62}$$

$$= 0,2367$$

$$\emptyset = 13,32^\circ$$

(16)
[50]

TOTAL / TOTAAL: 300