

**GAUTENG DEPARTMENT OF EDUCATION
GAUTENGSE DEPARTEMENT VAN ONDERWYS**

**SENIOR CERTIFICATE EXAMINATION
SENIORSERTIFIKAAT-EKSAMEN**

TECHNIKA (ELECTRONICS / ELEKTRONIES) HG

POSSIBLE ANSWERS / MOONTLIKE ANTWOORDE SUPP 2007

QUESTION / VRAAG 1

ELECTRIC CURRENT THEORY / ELEKTRIESE STROOMTEORIE

1.1 $X_{L(\text{ser})} = 2\pi f l$

$$= 2\pi \times 50 \times 0,5$$

$$= 157,079 \text{ O} \quad (3)$$

$$X_{L(\text{par1})} = 2\pi f l$$

$$= 2\pi \times 50 \times 1,27$$

$$= 398,982 \text{ O} \quad (3)$$

$$X_{C(\text{par2})} = \frac{1}{2\pi f c}$$

$$= \frac{1}{2\pi \times 50 \times (320 \times 10^{-6})}$$

$$= 159,155 \quad (2)$$

$$Z_{(\text{par})} = \sqrt{R^2 + X_L^2}$$

$$= \sqrt{300^2 + 398,982^2}$$

$$= 499,2 \text{ O} \quad (3)$$

$$Z_{(\text{pa2})} = \sqrt{R^2 + X_C^2}$$

$$= \sqrt{500^2 + 159,155^2}$$

$$= 524,92 \text{ O} \quad (3)$$

$$\begin{aligned}
 Z_{(\text{par})} &= \frac{Z_{\text{par}1} \times Z_{\text{par}2}}{Z_{\text{par}1} + Z_{\text{par}2}} \\
 &= \frac{499,2 \times 524,92}{499,2 + 524,92} \\
 &= 255,82 \text{ O}
 \end{aligned} \tag{3}$$

$$\begin{aligned}
 Z_{(\text{ser})} &= \sqrt{R^2 + X_L^2} \\
 &= \sqrt{110^2 + 157,079^2} \\
 &= 191,76 \text{ O}
 \end{aligned} \tag{3}$$

$$\begin{aligned}
 I_{\text{TOTAL}} &= \frac{V_{\text{TOT}}}{Z_{\text{TOT}}} & Z_{\text{TOT}} &= Z_{\text{SER}} + Z_{\text{par}} \\
 &= \frac{12}{447,58} & &= 191,76 + 255,82 \\
 &= 26,81 \text{ mA} & &= 447,58
 \end{aligned} \tag{2}$$

(3)

[25]

QUESTION / VRAAG 2

- 2.1.1 Diode (1)
- 2.1.2 LED / *Liguitstralende diode* (2)
- 2.1.3 Bulb / *Lig* (1)
- 2.1.4 2,2 – 4,7 μFarad / 25 Volt Polarised Capacitor / *Gepolariseerde kapasitor* (4)
- 2.1.5 Triac / *Triak* (2)
- 2.2 “Darlington Pair” / *-paar* (1)

WORKING PRINCIPLE / WERKBEGINSEL

High input Impedance

Low output Impedance

High Current Gain, typical 1 000 or more

Low voltage gain, typical less than one

The emitter current of the first transistor is the base current for the second transistor

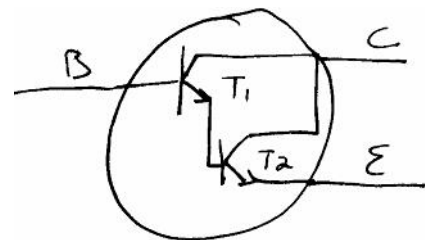

Biasing arrangement: Positive on base, Positive on Collector and Negative on Emitter

Hoë inset-impedansie

(10)

Lae uitset-impedansie

Hoë stroomwins, tipies 1 000 of meer

Lae spanningswins, tipies minder as een

Die emittorstroom van die eerste transistor is die basisstroom vir die tweede.

Voorspanning: Positief op basis, Positief op kollektor en negatief op die emittor

2.3 Transistor (1)

Biassing Points / Voorspanning-punte

The aim of biasing is to achieve a certain condition of current and voltage called the operating point (Q-point) (3)

Saturation region – Work as a switch (On) (2)

Active region – Work as an Amplifier (2)

Cut-off region – Work as a switch (Off) (2)

Die doel van voorspanning is om ? sekere toestand van stroom of spanning te verseker en word die werkpunt genoem (Q-punt)

Versadigingsgebied – Werk as ? skakelaar (Aan)

Aktiewe gebied – Werk as ? versterker

Afsnygebied – Werk as ? skakelaar (Af)

2.4 Transport in anti-static containers / Vervoer in anti-statische houers.

- Store unutilized units in conductive sponge / *Ongebruikte eenhede moet in geleidende spons gestoor word.*
- Use earthed point soldering irons / *Soldeerboute moet geaard wees.*
- Use specially earthed wristbands / *Gebruik geaarde gewrigsbande.*
- Connect all test equipment to earth / *Aard alle toets-toerusting.*
- All unutilized inputs must be connected to Vdd or Vss / *Ongebruikte insette moet verbind word aan Vdd of Vss.*

Any Three / *Enige Drie* (3)

[34]

QUESTION / VRAAG 3
AMPLIFIERS / VERSTERKERS

$$\begin{aligned}
 3.1 \quad V_e &\cong \frac{1}{10} \times (V_{cc}) & R_e &= \frac{V_e}{I_c} \\
 &\cong \frac{1}{10} \times (20) & &= \frac{2}{1 \times 10^{-3}} \\
 &\cong 2 \text{ volt} \rightarrow & &= 200 \Omega \rightarrow
 \end{aligned} \tag{3}$$

Note / neem kennis: $I_c = I_e$ (1)

$$\begin{aligned}
 R_c &= \frac{V_{cc} - V_{ce} - V_e}{I_c} \\
 &= \frac{20 - 8 - 2}{1 \times 10^{-3}} \\
 &= 1 \text{ k}\Omega \rightarrow
 \end{aligned} \tag{3}$$

$$\begin{aligned}
 V_b &= V_e + V_{be} \\
 &= 2 + 0,7 \\
 &= 2,7 \text{ volt}
 \end{aligned} \tag{3}$$

$$\begin{aligned}
 R_{B2} &= \frac{1}{10(\beta R_e)} \\
 &= \frac{80 \times 200}{10} \\
 &= 1,6 \text{ k}\Omega \rightarrow
 \end{aligned} \tag{3}$$

$$\begin{aligned}
 V_b &= \frac{R_{b2}}{R_{b1} + R_{b2}} (V_{cc}) \\
 2,7 &= \frac{1,6 \times 10^3 \times 20}{R_{b1} + 1,6 \times 10^3} \\
 R_{B1} &= \frac{32\,000}{2,7} - 1\,600 \\
 &= 10,25 \text{ k}\Omega \rightarrow
 \end{aligned} \tag{4} \quad [20]$$

- 3.1.1 A. Rb1 and / en Rb2 (2)
- B. Rc and / en 10 μ Farad Cap (2)
- C. Re and / en Ce (2)

3.2

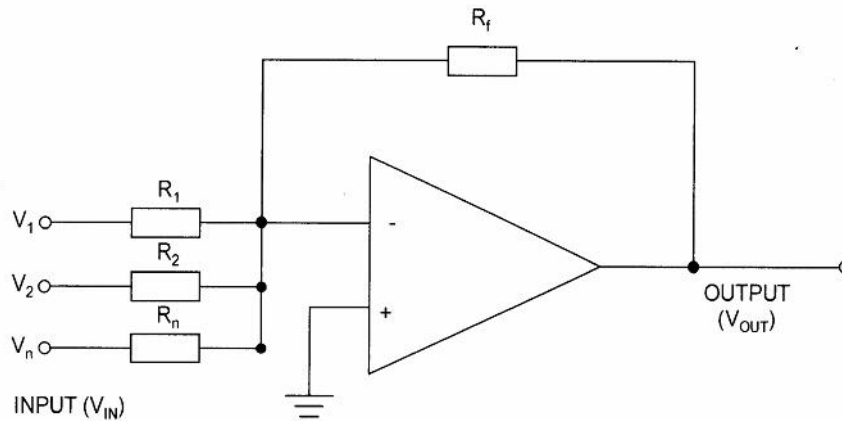

$$V_0 = \left(\frac{V_1 R_f}{R_1} + \frac{V_2 R_f}{R_2} + \dots \right)$$

$$V_0 = \left(\frac{+10 \times 60000}{10000} + \frac{-12 \times 60000}{5000} + \frac{-6 \times 60000}{30000} \right)$$

$$= -96 \text{ volt} \rightarrow$$

(7)

(5)

$$3.3 \quad \text{Db} = 10 \text{ Log (Power ratio)}$$

$$= 10 \text{ Log (50/25)}$$

$$= 10 \text{ Log 2}$$

$$\text{Gain} = 3 \text{ dB}$$

(4)

[42]

QUESTION / VRAAG 4

SWITCHING AND CONTROL CIRCUITS / SKAKEL- EN BEHEERKRINGE

4.1 LIGHT DIMMER / LIGVERDOWWER

- 470 K adjusts the voltage and has a direct influence on the time constant.
 $T = C \times R$. (3)
- The Diac and Triac are bi-directional devices. (2)
- The diac ensures a positive and negative pulse to the gate terminal of the Triac to keep the Triac on. (a Diac will have a predetermined value eg. 30V, to be overcome before switching on and prevent flickering. (3)
- The line choke is included to eliminate Radio/TV interference. (2)
- 470 r verstel die spanning en het 'n direkte invloed op die tydkonstante.
 $T = C \times R$.
- Die diak en triak gelei in beide rigtings.
- Die diak het 'n voorafbepaalde waarde (bv. 30 volt) voordat dit aanskakel en verseker 'n positiewe en negatiewe puls by die hek van die triak. Flikkering word sodoende voorkom.
- Die lynspoel beskerm die kring teen Radio/TV-inmenging.

4.2 **STEREO HEADPHONE MONITOR / STEREO-OORFOONMONITOR**

IC1 and IC2 are power amplifiers / *IC1 en IC2 is kragversterkers.* (1)

The power supply consist of a 6V or 9V battery / *Die kragbron is 'n 6 V- of 9 V-battery.* (1)

D1 gives reverse polarity protection / *D1 bied omgekeerdepolariteit-beskerming.* (2)

To activate IC 1and IC2 - Positive to pin 6 and Negative to pin 4

Om IC1 en IC2 te aktiveer - Pos na pen 6 en neg. na pen 4 (2)

Signal input to pin 3 / *Sein-inset na pen 3* (1)

Vr1 and Vr11 balance the left and right channels / *Vr1 en Vr11 balanseer die linker- en regterkanale.* (1)

Vr2 and Vr12 is a dual volume control / *Vr2 en Vr12 is ? gekoppelde volume-beheer.* (2)

3

4.3.1

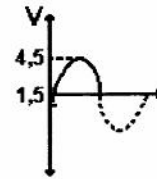
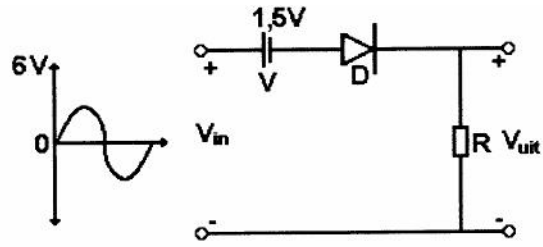

(4)

4.3.2

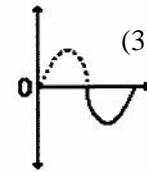
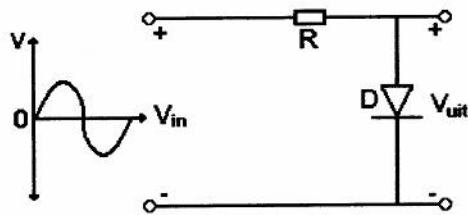

(3)

4.3.3

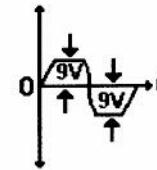
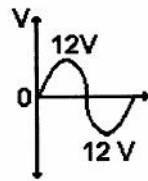
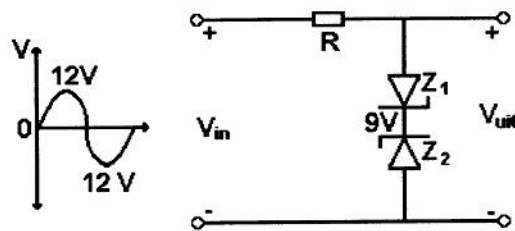

(4)

4.3.4

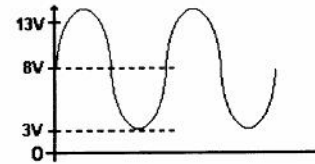
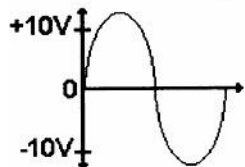
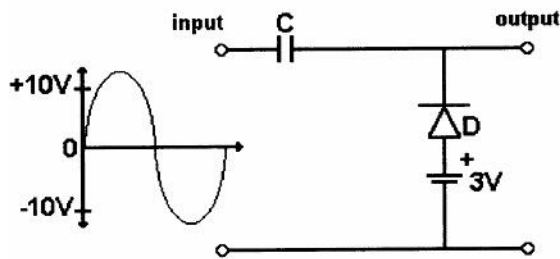

(4)

4.4 Any logical explanation / *Enige logiese verduideliking*

One mark for each correct fact / *Een punt vir elke korrekte feit.*

(15)
[50]

QUESTION / VRAAG 5
OSCILLATORS / OSSILLATORS

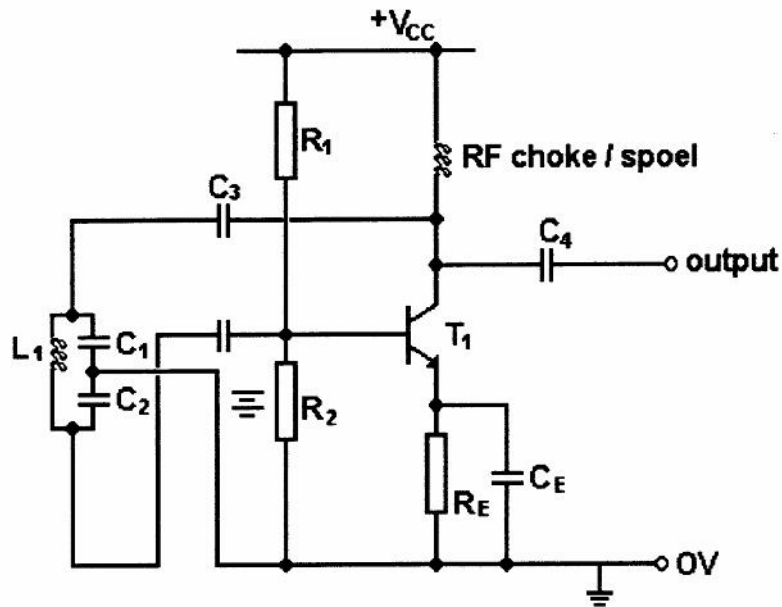

(10)

OPERATION

T_1 is forward-biased by R_1 and R_2 .
 C_1 , C_2 and L_1 form the tank circuit.
 C_1 , C_2 and L_1 determine the frequency of the circuit.
 Feedback through C_3 .

WERKING

T_1 word meevoorgespan deur middel van R_1 en R_2 .
 C_1 , C_2 en L_1 vorm die resoneernetwerk.
 C_1 , C_2 en L_1 bepaal die frekwensie van die kring.
 Terugvoering geskied deur C_3 .

(4)

Note that any correct circuit explaining the operating principle of an oscillator should be accepted

Enige korrekte verduideliking moet aanvaar word.

- 5.2 When mechanical stress is applied across the faces of a crystal, a difference of potential develops opposite the faces of the crystal. Similarly, a voltage applied across the faces of a crystal will result in mechanical vibrations. These vibrations have a natural resonant frequency dependant on the crystal.

Wanneer meganiese druk op 'n kristal toegepas word, veroorsaak dit 'n potensiaalverskil oor die kristal. Wanneer 'n potensiaalverskil op 'n kristal toegepas word, veroorsaak dit op soortgelyke wyse dat die kristal sal vibreer (ossilleer) teen 'n resonante frekwensie eie aan die tipe kristal.

(4)
[18]

QUESTION / VRAAG 6
COMPUTER PRINCIPLES / REKENAARBEGINSELS

6.1 $F = \overline{ABC} + \overline{AB} + \overline{AC}$

$F = \overline{ABC} + \overline{AB} + \overline{AC}$

$F = \overline{(\overline{ABC}) \cdot (\overline{AB}) \cdot (\overline{AC})}$

(2)

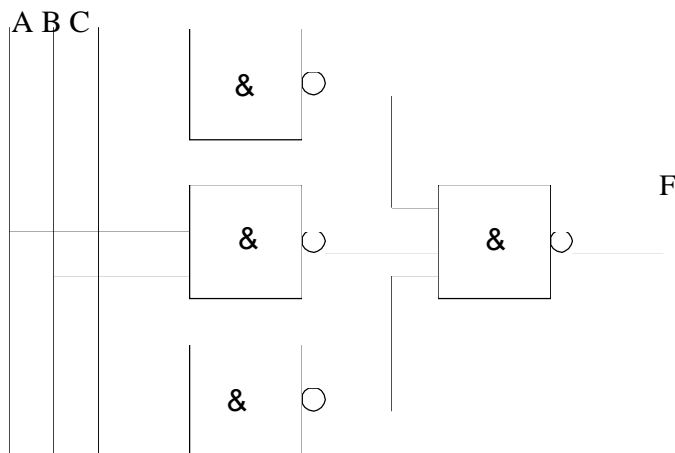

(4)

(6)

$$6.2 \quad A + B = A B + A \bar{B}$$

$$\overline{A B + A B}$$

$$A B . A B$$

$$(A + B)(A + B)$$

$$(A + B)(A + B)$$

$$0 + A B + A . B \quad (5)$$

6.3.1 Legend : A = Water reservoir 1

B = Water reservoir 2

C = Water reservoir 3

F = Alarm (8)

A	B	C	ALARM
0	0	0	1
0	0	1	1
0	1	0	1
0	1	1	0
1	0	0	1
1	0	1	0
1	1	0	0
1	1	1	0

Positive logic is used to solve this problem / *Positiewe logika word gebruik om hierdie probleem op te los.* (Leerdere mag gebruik maak van enige aanvaarbare tegniek / Learners are allowed to use any acceptable method to solve the problem.)

6.3.2 $F = A \cdot B \cdot C + A \cdot B \cdot \bar{C} + A \cdot \bar{B} \cdot C + A \cdot \bar{B} \cdot \bar{C}$.

6.3.3

$F = A \cdot B \cdot C + A \cdot B \cdot \bar{C} + A \cdot \bar{B} \cdot C + A \cdot \bar{B} \cdot \bar{C}$.

$F = A \cdot B \cdot (C + \bar{C}) + A \cdot \bar{B} \cdot C + A \cdot \bar{B} \cdot \bar{C}$.

$F = A \cdot B + A \cdot \bar{B} \cdot C + A \cdot \bar{B} \cdot \bar{C}$.

$F = A \cdot B + C (A \cdot \bar{B} + A \cdot B)$.

$F = A \cdot B + C (A \oplus B)$

(7)

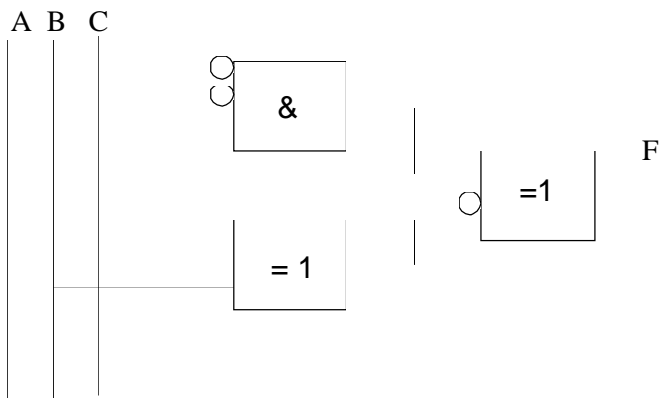

(6)

6.4

2	25	1	MSB
2	12	0	
2	6	0	
2	3	1	
2	1	1	
	0		LSB

$0,375 \times 2 = 0,75$ carry / oordrag	0	LSB
$0,75 \times 2 = 1,5$ carry / oordrag	1	
$0,5 \times 2 = 1$ carry / oordrag	1	MSB

$25,375 = 11001,011$

2	7	1	MSB
2	3	1	
2	1	1	
	0		LSB

7 = 111

11001,011
+ 111,000
100000,011

(4)

6.5

Action	Q_0	S	R	\bar{Q}	Q	Conclusion
Assume	0	0	0	1	0	This is a stable state.
Apply 1 to S	0	1	0	0	1	Unstable state; Q changes.
(Q_0 becomes 1)	1	1	0	0	1	Stable.
Remove 1 from S	1	0	0	0	1	The stable state after SET.
Apply 1 to S again	1	1	0	0	1	No change in Q.
Remove 1 from S	1	0	0	0	1	The stable state after SET.
Apply 1 to R	1	0	1	0	0	Unstable state; Q changes.
(Q_0 becomes 0)	0	0	1	1	0	Stable.
Remove 1 from R	0	0	0	1	0	The stable state after RESET.
Apply 1 to S and R	0	1	1	0	0	Unacceptable; $Q \neq \bar{Q}$.

(16)

6.6 Counters and Registers / *Tellers en Registers*

(2)

[54]

QUESTION / VRAAG 7
INFORMATION TRANSFER / INLIGTING-OORDRAG

7.1

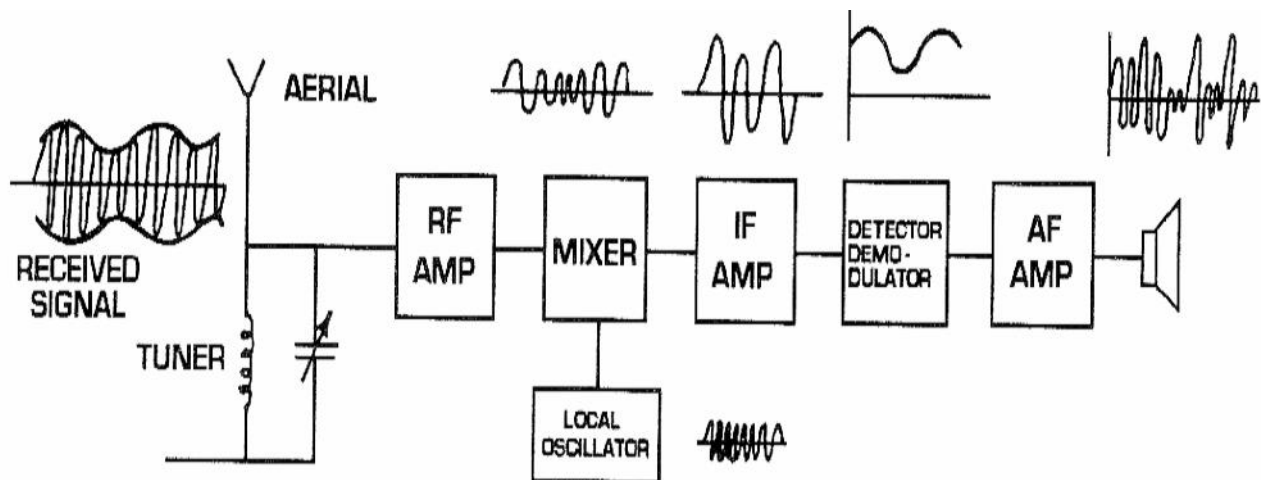

(15)

QUESTION / VRAAG 7**INFORMATION TRANSFER / INLIGTINGOORDRAG**

7.2

The interfacing between fibre cable ends is also critical as any mis-match between coupling the ends will also contribute to large losses of signal power. When two fibres are not perfectly aligned along their centre axes, losses will result due to loss of light as well as some reflection of light from polished flat end faces.

The major causes of signal power losses are:

1. **Lateral displacement** where the two fibre axes are not aligned.
2. **End separation** where any slight air gap will introduce a change of refractive index leading to some internal reflection loss.
3. **Angular misalignment** with two ends misaligned, losing much light signal power.

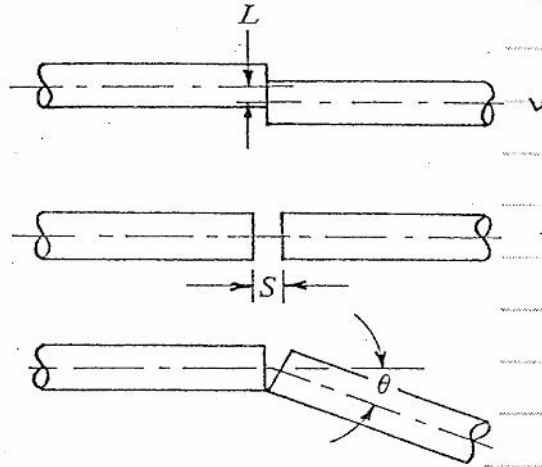

Die las van optiese vesels is uiters kritiek, a.g.v. die lynversteuring van die binnevlak van die vesel wat kan plaasvind. Enige verskuiwing van hierdie oppervlakke bring energieverliese mee soos bo geïllustreer.

(6)

7.3 Optic fibre systems have broader bandwidth and can thus carry more traffic due to a wider range of modulation that can take place. Not prone to lightning and high measure of security, etc.

Optiese vesel het 'n groter bandwydte en kan sodoende meer "verkeer" hanteer. Dit is weerligbestand en het geen waarde in die sluikhandel nie.

(2)

7.4

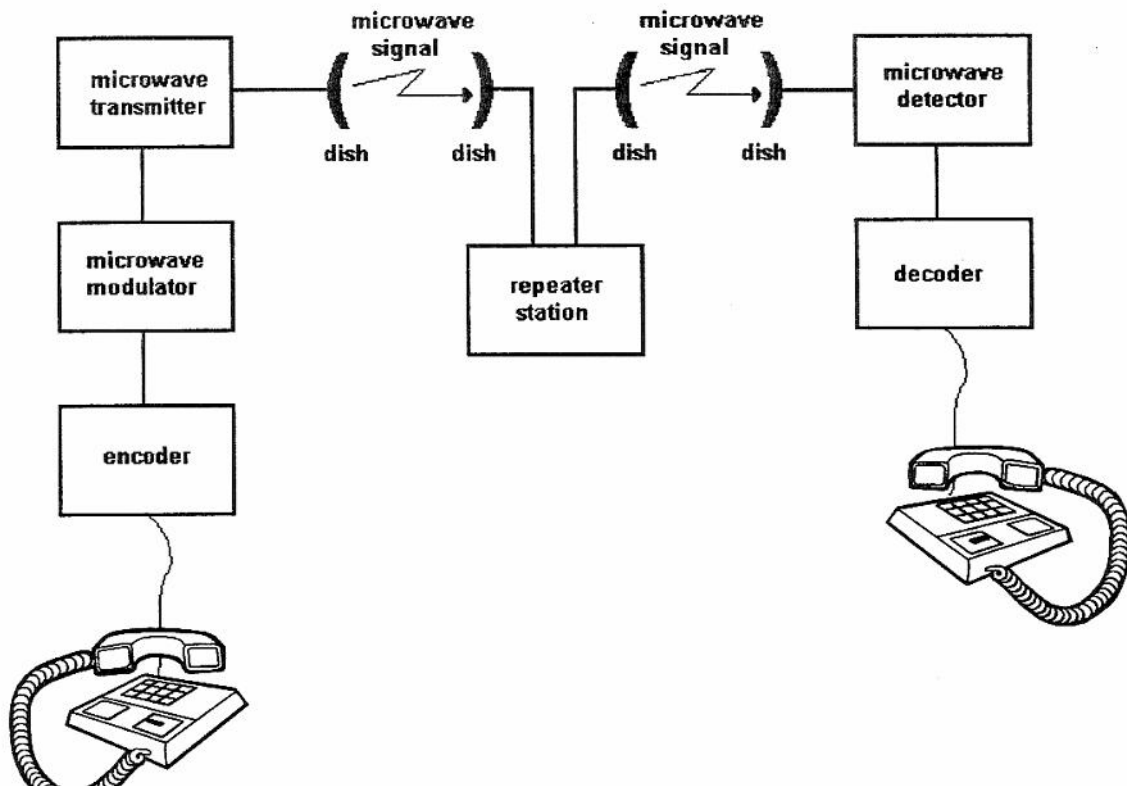

(12)

[35]

QUESTION / VRAAG 8
MEASURING INSTRUMENTS / MEETINSTRUMENTE

8.1

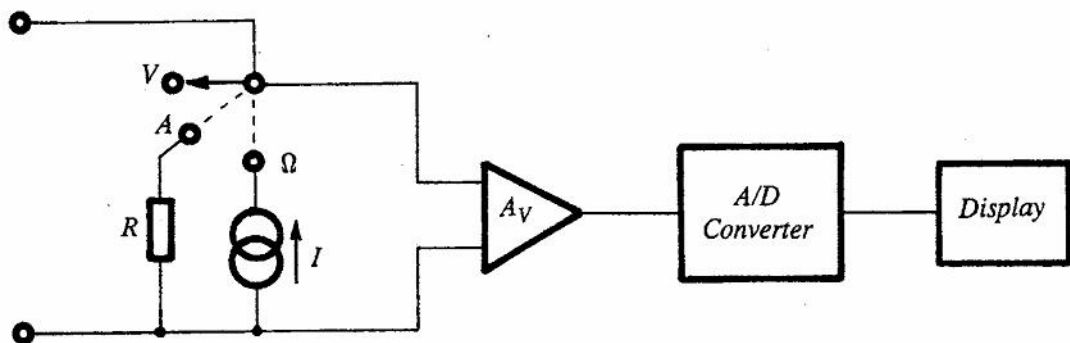

(10)

8.2 240 kΩ

(2)

8.3 $V = 0,7 \times 10 = 7$ volt (2)

8.3.1 $V_{p-p} = \text{No. Div.} \times V/\text{Div.} \times 2$
 $= 1,6 \times 100 \text{ mV} \times 2$
 320 mVolt (3)

8.3.2 $t = \text{No. Div.} \times t/\text{Div.}$
 $= 3,2 \times 10 \times 10^{-6}$
 $= 32 \mu \text{ Sec.}$ (3)

$$f = \frac{1}{t}$$

$$f = \frac{1}{32 \times 10^{-6}}$$

$$f = 31,25 \text{ kHz}$$

(3)
[21]

QUESTION / VRAAG 9
SAFETY PRECAUTIONS / VEILIGHEID

- 9.1 Keep floor clear of hazards / *Hou die vloer skoon van enige ongewenste materiale.*
 Empty waste bins regularly / *Maak die vullisblik gereeld leeg.*
 Clean up spilt oil / *Maak olie wat gemors het onmiddellik skoon.*
 Always clean up / *Ruim altyd op.*
 Put everything back in its place / *Plaas alles terug in die korrekte plek.*
 Any similar answer / *Enige soortgelyke antwoord* (5)
- 9.2.1 Fire Hose / *Brandslang* (1)
- 9.2.2 Location / *Plekaanduiding* (1)
- 9.2.3 Fire Extinguisher / *Brandblusser* (1)
- 9.3 Electrical faults / *Elektriese foute*
 Open flames / *Oop vlamme*
 Chemical reactions / *Chemiese reaksies*
 Lightning / *Weerlig* Any similar answer / *Enige soortgelyke antwoord* (2)

- 9.4.1 True / Waar (1)
- 9.4.2 False / On waar (1)
- 9.4.3 False / On waar (1)
- 9.4.4 True / Waar (1)

9.5 After someone is infected with HIV, it can take up to three months for it to show up in an antibodies test. These three months are commonly known as the “window period”

Indien 'n persoon met die HI-virus besmet is, kan dit tot drie maande neem om die virus in 'n teenliggaampie-toets waar te neem. Hierdie tydperk word na verwys as die vensterperiode.

(3)
[17]

300