

**GAUTENG DEPARTMENT OF EDUCATION
GAUTENGSE DEPARTEMENT VAN ONDERWYS**

**SENIOR CERTIFICATE EXAMINATION
SENIORSERTIFIKAAT-EKSAMEN**

TECHNIKA (ELECTRICAL/ELEKTRIES) SG

**Possible Answers / Moontlike Antwoorde
Feb / Mar / Maart 2006**

QUESTION 1 / VRAAG 1

1.1

$$\begin{aligned} R &= V/I && (1) \\ &= 100/2 && (1) \\ &= \mathbf{50 \Omega} && (1) \end{aligned}$$

$$\begin{aligned} Z &= V/I && (1) \\ &= 150/0,8 && (1) \\ &= \mathbf{187,5 \Omega} && (1) \end{aligned}$$

$$Z^2 = R^2 + XL^2 \quad (1)$$

$$XL = 2 \pi f L \quad (1)$$

$$XL^2 = Z^2 - R^2 \quad (1)$$

$$L = \frac{XL}{2 \pi f} \quad (1)$$

$$\begin{aligned} &= 187,5^2 - 50^2 && (1) \\ &= 35156,25 - 2500 && (1) \end{aligned}$$

$$\begin{aligned} XL^2 &= 32\ 656,25 && (1) \\ &= \mathbf{180,710 \Omega} && (1) \end{aligned}$$

$$L = \mathbf{479,3 \text{ mH}} \quad (1)$$

[13]

1.2 Inductive reactance / Induktiewe reaktansie

$$\begin{aligned} XL &= 2 \pi f L && (1) \\ &= 2 \times \pi \times 50 \times 50 \times 10^{-3} && (1) \\ &= \mathbf{15,707 \Omega} && (1) \end{aligned}$$

Capacitive reactance / Kapasitiewe reaktansie

$$\begin{aligned} Xc &= \frac{1}{2 \times \pi \times f \times C} && (1) \\ &= 1 / 2 \times \pi \times 50 \times 50 \times 10^{-6} && (1) \\ &= \mathbf{63,661 \Omega} && (1) \end{aligned}$$

$$\begin{aligned} IR &= V/R && (1) & Ic &= V/Xc && (1) & IL &= V/XL && (1) \\ &= 50 / 50 && (1) & &= 50 / 63,661 && (1) & &= 50 / 15,707 && (1) \\ &= \mathbf{1 \text{ Amp}} && (1) & &= \mathbf{0,785 \text{ Amp}} && (1) & &= \mathbf{3,1832 \text{ Amp}} && (1) \end{aligned}$$

[10]

1.2.2

$$\begin{aligned}
 I_T &= \sqrt{I_R^2 + (I_L - I_C)^2} & (1) \\
 &= \sqrt{1^2 + 2,398^2} & (1) \\
 &= \sqrt{3,3982} & (1) \\
 &= 2,595 \text{ Amp} & (1) \quad (3)
 \end{aligned}$$

1.2.4

Phase angle / Fasehoek

$$\begin{aligned}
 \tan \Theta &= \frac{I_L - I_C}{I_R} & (1) \\
 &= 2,398 / 1 & (1) \\
 \Theta &= \tan^{-1} 2,398 & (1) \\
 \Theta &= 67,363^\circ & (1) \quad (4)
 \end{aligned}$$

1.2.5

$$\cos \Theta = \frac{R}{Z} = \frac{50}{69,28} = 0,72 \quad (3)$$

1.2.3

$$\begin{aligned}
 Z &= \sqrt{R^2 + (X_C - X_L)^2} \\
 Z &= \sqrt{50^2 + (63,661 - 15,707)^2} \\
 &= \sqrt{4799,59} \\
 &= 69,28 & (3)
 \end{aligned}$$

1.2.6

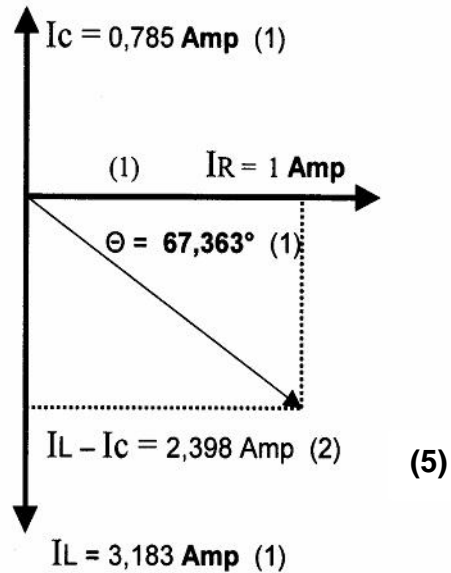

[41]

QUESTION/VRAAG 2

2.1

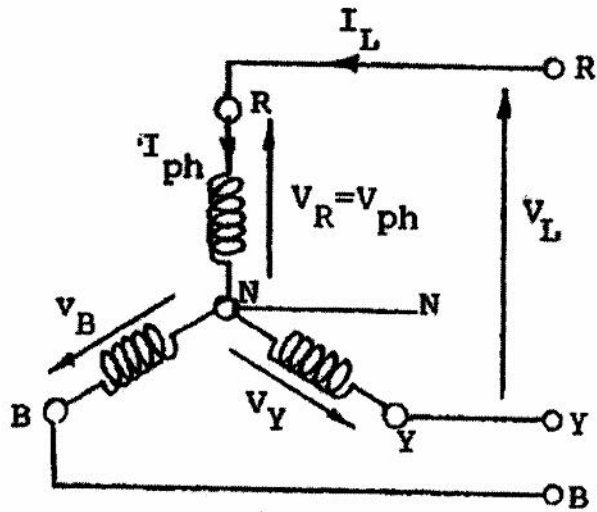

(3)

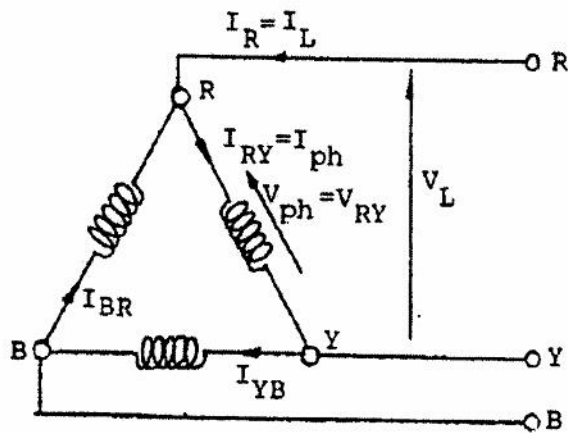

(3)

2.2

$$V_L = \sqrt{3} \times V_f \quad (1)$$

$$V_f = \frac{V_L}{\sqrt{3}}$$

$$V_f = 500 / \sqrt{3} \quad (1)$$

$$= 288,675 \text{ volt} \quad (1)$$

(3)

2.3

$$\text{kVA} = \sqrt{3} \times V_L \times I_L$$

(3)

[12]

QUESTION 3/VRAAG 3

3.1 Given: kVA = 400 kVA Gegee: :
V_{ph2} = 250 volt

3.1.1

$$\begin{aligned} V_L &= \sqrt{3} V_{ph} && (1) \\ &= \sqrt{3} \times 250 && (2) \\ &= \mathbf{433,01 \text{ volt}} && (1) \end{aligned}$$

3.1.2 400 kVA = $\sqrt{3} \times V_L \times I_L$ (1)

$$\begin{aligned} I_L &= \frac{400\,000}{\sqrt{3} \times 433,01} \quad (1) \\ &= \mathbf{533,333 \text{ Amp}} \text{ thus/} && (1) \quad I_L = I_{ph} = \mathbf{533,333 \text{ Amp}} \quad (2) \end{aligned} \quad (5)$$

3.1.3

$$\begin{aligned} P &= \sqrt{3} \times V_L \times I_L \times \cos \Theta && (1) \\ &= \sqrt{3} \times 433,01 \times 533,333 \times 0,8 && (1) \\ &= \mathbf{319,998 \text{ kW}} && (1) \end{aligned} \quad (3)$$

3.2

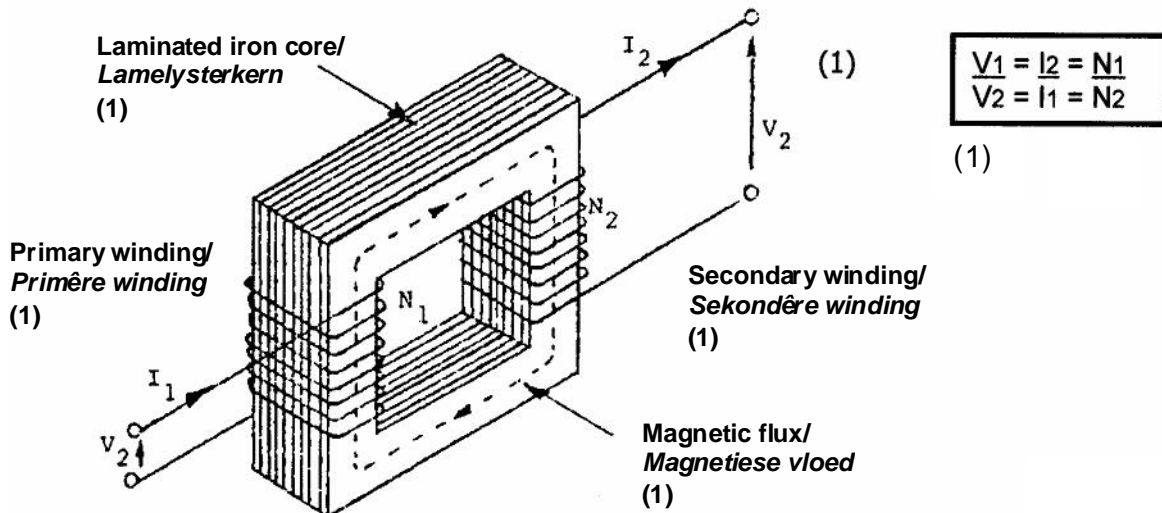

- When all alternating current is connected across the primary coil, the alternating current induces a magnetic flux in the core. The core is laminated to prevent excess heat.
- Alternating flux induced an emf in the secondary coil with the same frequency.
- Mutual inductance in the transformer.
- If a load is connected across the secondary winding a current will flow.
- *Wanneer ? wisselstroom oor die primêre spoel gekoppel word, vloei daar ? wisselstroom wat ? magnetiese vloed in die kern opwek. Die kern is gelamineer om oorverhitting te voorkom.*
- *Wisselstroom induseer ? emk in die sekondêre wikkeling met dieselfde frekwensie.*
- *Wedyrsydse induksie het plaasgevind in die transformator.*
- *Indien daar nou ? las aan die sekondêre kant gekoppel word, sal daar ? stroom deurvloei.*

(10)

QUESTION/VRAAG 4

4.1

MC = Main contactor / Hoofkontaktor



= Delta contactor / Delta-kontaktor



= Star contactor / Sterkontaktor



= Time relay / Tydreël relê

- When the start button is pressed, the main contactor will close. Coil is activated.v
 - The following contactors will be activated:
 1. Main contactsv
 2. Latching MC1v
 3. MC2 that switches the time relay on. v
 4. MC3 which activates the star contactor.v
 5. Star 1 contact opens so that the delta circuit doesn't activate.v
 - The motor will run in star till the time relay runs out of time and then the following will happen:
 1. TR1 opens which opens the star contactor.
 2. TR2 closes, star 1 also closes and the delta contactor closes.v
 3. Delta 1 opens so that the star circuit can't activate.v
 4. The motor will now run in delta till the stop button is pressed. v
 - *Wanneer die aansitskakelaar gedruk word, sal die hoofkontaktor sluit. Spoel word bekrag.v*
 - *Die volgende kontaktors word geaktiveer:*
 1. *Hoofkontaktev*
 2. *Inhoukontakte MC1v*
 3. *MC2 wat weer die tydreël-relê aanskakelv*
 4. *MC3 wat weer die ster-kontaktor aktiveer v*
 5. *Ster 1 se kontak maak oop, sodat die delta-kring nie kan aangaan niev*
 - *Die motor sal nou in ster loop totdat die tyd om is het en dan sal die volgende gebeur:*
 1. *TR1 maak oop, wat die ster-kontaktor oopmaak. v*
 2. *TR2 maak toe, nou is ster 1 ook toe en die delta-kontaktor maak toe. v*
 3. *Nou maak delta 1 oop sodat die ster-kring nie geaktiveer kan word nie. v*
 4. *Die motor loop nou in delta totdat dit weer afgeskakel word. v* (10)
- 4.2 The speed at which the rotor rotates is the rotor speed. It is always less than the synchronous speed.
Die spoed waarteen die rotor draai, is die rotorspoed. Dit is altyd stadiger as die sinchrone spoed. (3)
- 4.3 By changing TWO of the three wires around e.g. L1 and L3 **or** L1 and L2 **or** L3 and L2.
*Deur TWEE van die drie drade om te ruil, bv. L1 en L3 **of** L1 en L2 **of** L3 en L2.* (2)
- 4.4 It is to provide the phase shift (split) so that the rotor can start turning.
Dit is om die faseverskuiwing te veroorsaak sodat die rotor kan begin draai. (3)

4.5

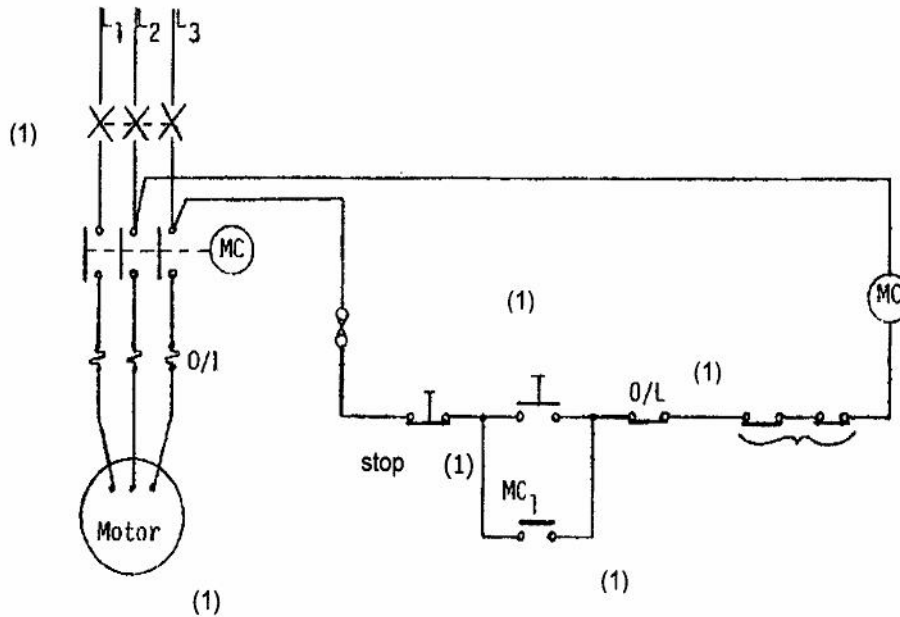

(9)
[27]

QUESTION/VRAAG 5

TRIAC ACOPERATION/

Control is achieved by firing the TRIAC with gate signals at the same point in both the positive and the negative half cycles (i.e. the same firing angle). Just like the SCR, the TRIAC resets and switches off when the supply voltage changes direction. To get the TRIAC to conduct another trigger, the signal must be fed to the gate.

TRIAC WS-WERKING

Beheer word behaal deur die TRIAK saam met hekseine te vuur, op dieselfde punt in die positiewe en negatiewe halvesiklusse (di. in dieselfde vuurhoek). Net soos die BSG, stel die TRIAKen skakel die toevoerspanning af wanneer die toevoerspanning rigting verander.

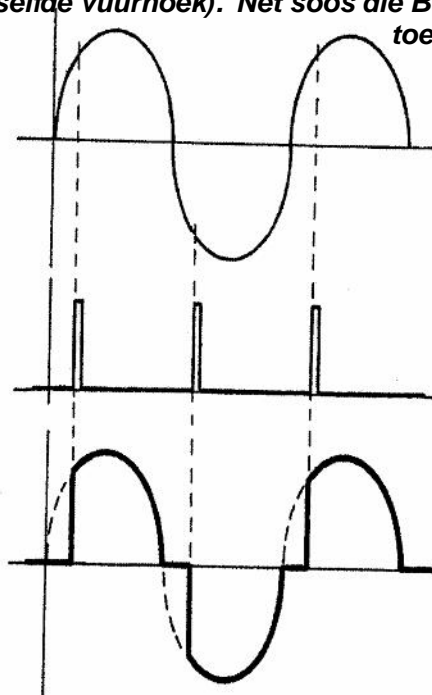
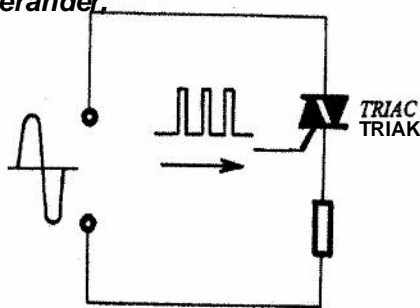

Om die TRIAK te kry om nog ? sneller te gelei, moet die sein aandie hek gevuur word.

TRIAC Characteristic Curve

As the TRIAC is a back-to-back SCR, its characteristic curve is identical to two SCR's each conducting in opposite directions. They each have a forward breakdown voltage V_{BO} and, with the appearance of a gate pulse, they will each conduct at that point.

TRIAC Kenmerkende Kurwe

As die TRIAK rug-aan-rug met ? BSG gebruik word, is sy kenmerkende kurwe identies aan twee BSG's wat in twee teenoorgestelde rigtings gelei. Hulle het albei ? afname-spanning V_{BO} en met die verskyning van ? hekpuls, sal albei op hierdie punt gelei.

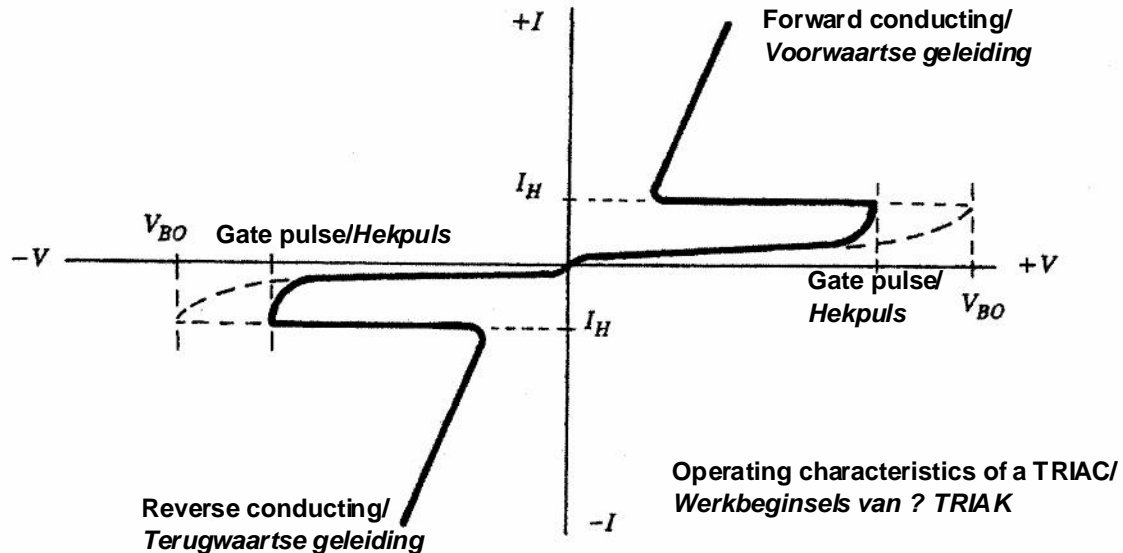

The device operates identically in either direction/Die toestel werk identies in beide rigtings.

With no gate signal, the device will break down at **break down voltage** V_{BO} . If a gate signal is introduced, the TRIAC immediately goes into break down and begins conducting. Once the **latching current** I_L has been exceeded, the gate terminal loses control (just like the SCR). The device will only turn off once its current falls below the **holding current** I_H value, or if its terminal voltage falls to zero. This occurs automatically as the AC supply reverses direction 100 times a second. The TRIAC takes about $1 \mu s$ to turn on and about $50 \mu s$ to turn off.

Met geen heksein nie, sal die toestel afbreek by **afbreekspanning** V_{BO} . Sodra die **grendelspanning** I_L oorskry word, verloor die hekterminaal beheer (nes die BSG). Die toestel sal afskakel sodra die spanning onder die houstroomwaarde I_H val of as die terminaalspanning terugval na sero. Dit gebeur outomaties omdat die WS-toevoer 100 keer per sekonde van rigting verander. Die TRIAK neem omtrent $1 \mu s$ om aan te skakel en omtrent $50 \mu s$ om af te skakel.

[10]

QUESTION/VRAAG 6

6.1 The candidate can draw any of three circuit diagrams.

Die kandidaat kan hier enige van drie kringbane teken:

- Common emitter amplifier/Gemeenskaplike-emittor-versterker
- Common base amplifier/Gemeenskaplike-basis-versterker
- Common collector amplifier/Gemeenskaplike-kollektor-versterker.

Also check the input and output waves, e.g. 180° phase shift by common emitter amplifier.

Kyk ook hier na die inset- en uitset-golwe, bv. 180° faseverskuiwing by gemeenskaplike-emittor versterker

(8)

6.2

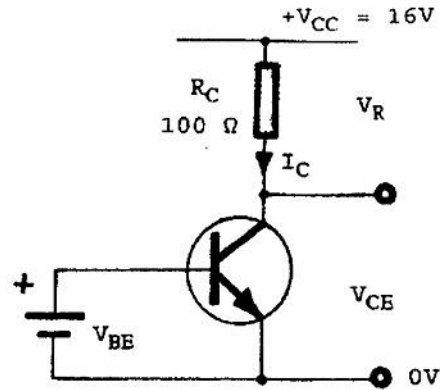
1. If/Indien $I_C = 8 \text{ mA}$

$$V_R = I_C R_C = 8 \text{ mA} \times 1000 \Omega \quad (2)$$

$$V_R = 8 \text{ V}$$

$$V_{CE} = V_{CC} - V_R = 16 \text{ V} - 8 \text{ V} = 8 \text{ V} = V_{UH} \quad (2)$$

2. If/Indien $I_C = 12 \text{ mA}$
(rise/styg)

$$V_R = I_C R_C = 12 \text{ mA} \times 1000 \Omega \quad (2)$$

$$V_R = 12 \text{ V}$$

$$V_{CE} = V_{CC} - V_R = 16 \text{ V} - 12 \text{ V} = 4 \text{ V} = V_{UL} \quad (2)$$

3. If/Indien $I_C = 4 \text{ mA}$
(falls/daal)

$$V_R = I_C R_C = 4 \text{ mA} \times 1000 \Omega \quad (2)$$

$$V_R = 4 \text{ V}$$

$$V_{CE} = V_{CC} - V_R = 16 \text{ V} - 4 \text{ V} = 12 \text{ V} = V_{UH} \quad (2)$$

When the information is represented in graph format, It helps to show that:

- when the collector current rises, the collector emitter voltage falls and
- when the collector current falls, the collector emitter voltage rises.

Wanneer die inligting in grafiekvorm voorgestel word, help dit om te sien dat:

- as die kollektorstroom styg, sal die kollektor-emitterspanning daal en
- as die kollektorstroom daal, sal die kollektor-emitterspanning styg.

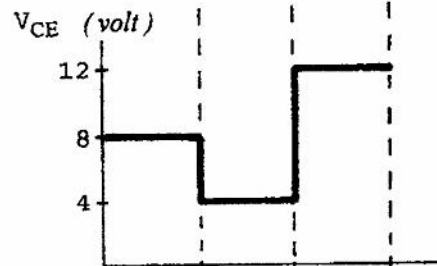
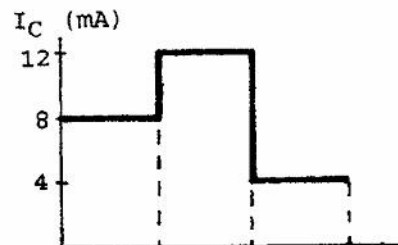

[20]

QUESTION 7 / VRAAG 7

7.1

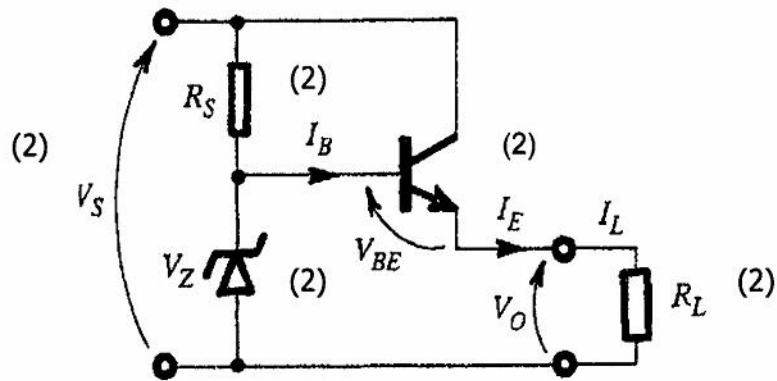

(10)

7.2

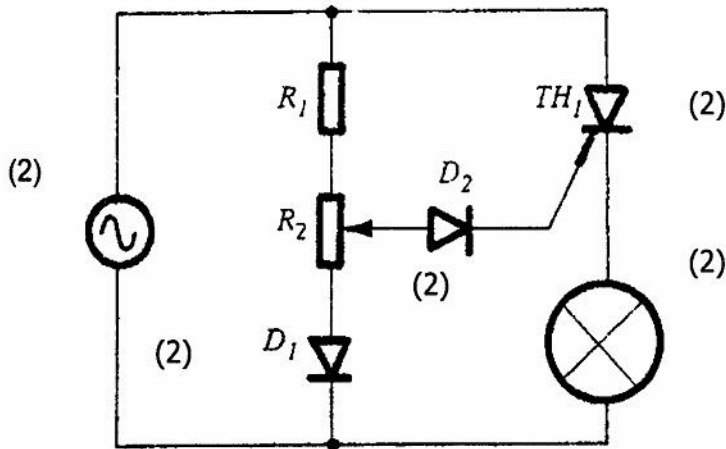

(10)

[20]

QUESTION 8 / VRAAG 8

Offset nil/
Lewering nul

Inverting input/
Omkeer van inset

Non-inverting input
Nie-omkeer van inset

- V Supply/
Toevoer

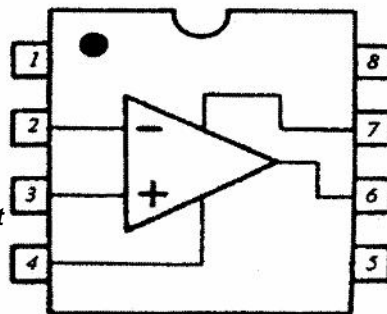

NC (No connection)/
Nulstroom

+ V Supply/
Toevoer

Output/
Uitset

Offset nil/
Lewering nul

(5)

8.2

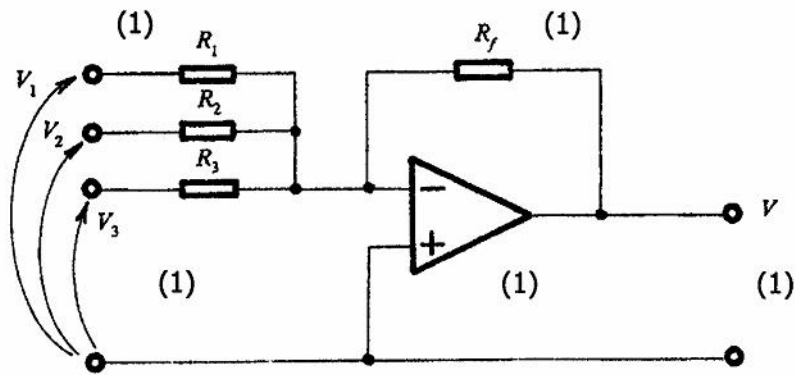

(5)

[10]

QUESTION 9/ VRAAG 9

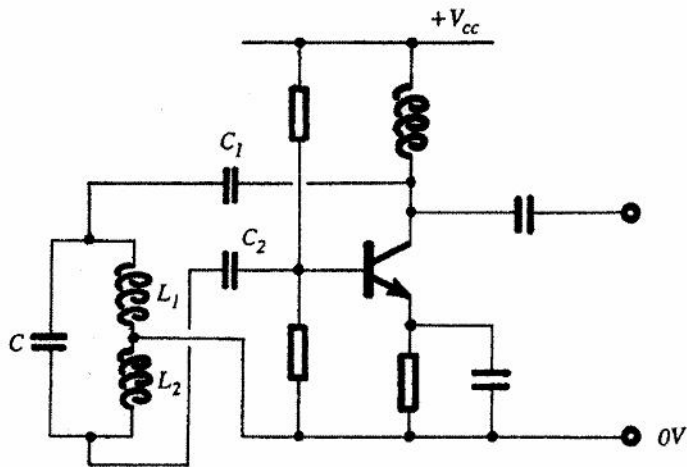

[7]

QUESTION 10/ VRAAG 10

10.1

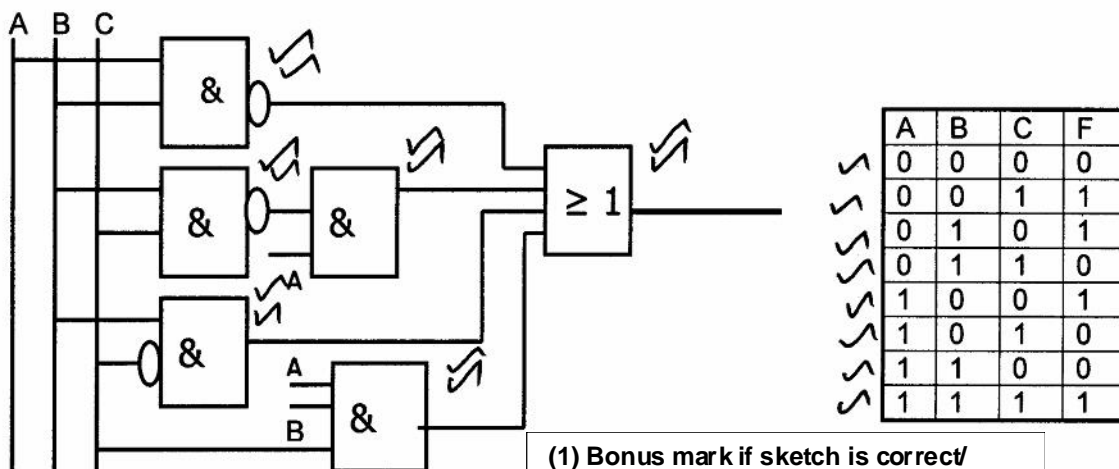

(1) Bonus mark if sketch is correct/
BONUSPUNT AS SKETS KORREK IS.

(11)

10.2

10.2.1 $11011_2 + 1111_2 = 101010_2$ (3)

10.2.2 $1010101_2 - 1001_2 = 1001100_2$ (4)

10.3

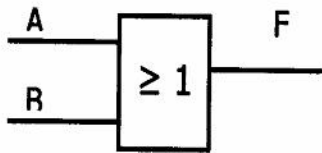

(3)

[21]

QUESTION 11/ VRAAG 11

11.1

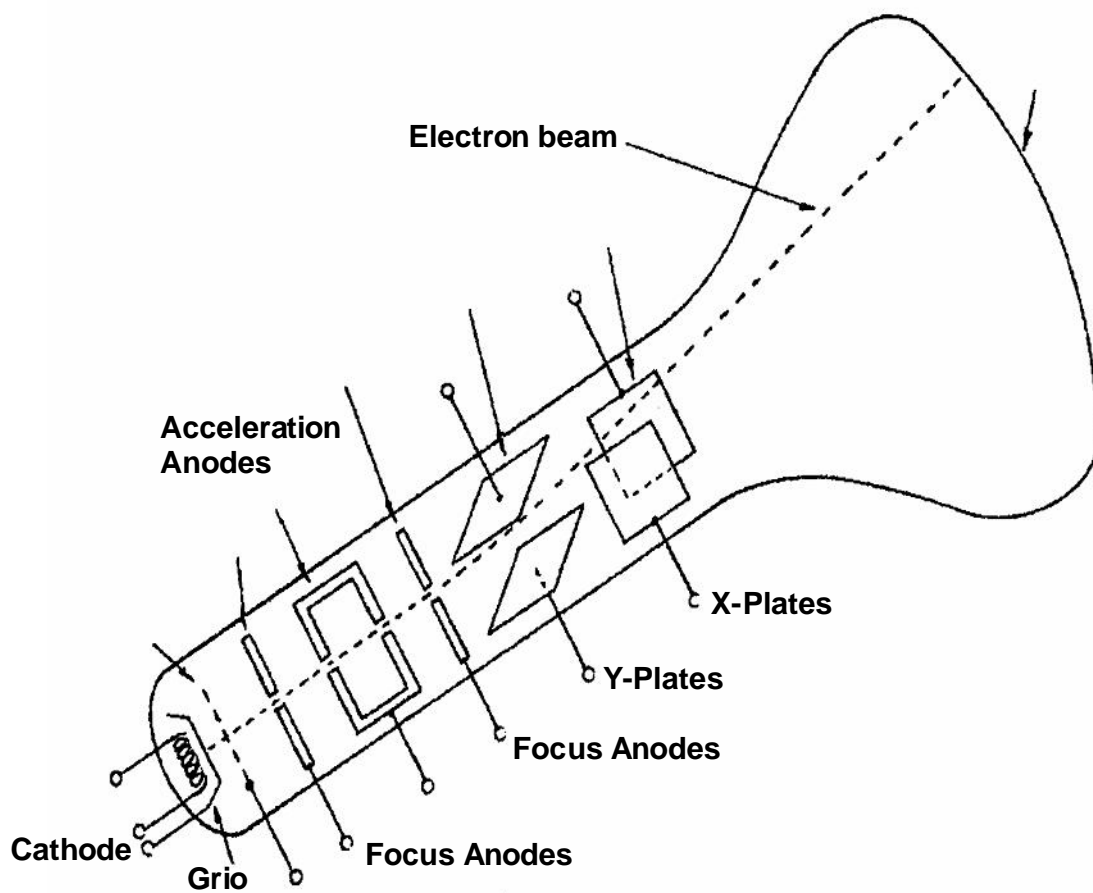

(6)

11.2

11.2 Testing of diodes

The recommended method of testing a diode is to disconnect it from the circuit and then test it with a multimeter. Some multimeters have a function to test diodes, transistors and capacitors and should be used according to the instructions applied for that specific meter. However, a diode may also be tested by making use of the resistance range of a multimeter.

Toetsing van diodes

Die aanbevole metode om 'n diode te toets is om dit van die multimeter te ontkoppel en dit te toets. Party multimeters het 'n funksie om diodes, transistors en kapasitors te toets en moet volgens die instruksies van die betrokke meter gebruik word. 'n Diode kan egter ook getoets word deur van die weerstandstrek van 'n multimeter gebruik te maak.

A high resistance range may be selected (Example 2 MW) and the diode should be tested for faulty conditions indicated in Figure 11.2 by means of word pictures. *'n Hoë weerstandstrek kan gekies word (byvoorbeeld 2 MW) en die diode moet getoets word vir foutiewe toestande soos in Figuur 11.2 aangedui word.*

Important: Please note that silver band on the diode indicates the cathode (Negative) side of the diode as illustrated below.
Belangrik: *Let daarop dat die silwer bandjie op die diode die katode (negatiewe) kant van die diode aandui, soos hieronder getoon word.*

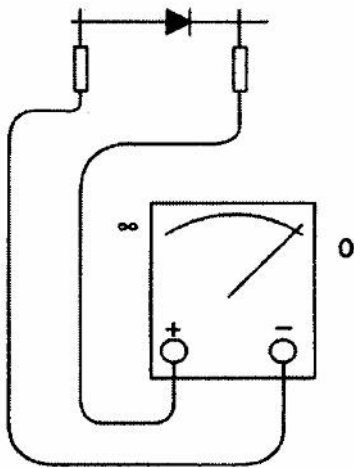
**Figure/Figuur 11.2 (a)**

Low resistance reading indicates the diode is forward bias.

Lae weerstandslesing dui aan dat die diode meevoorgespan is.

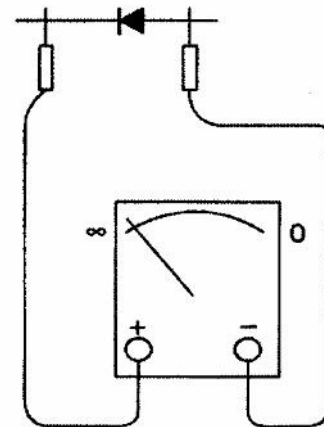
**Figure/Figuur 11.2 (b)**

An infinite resistance read indicates the diode is reverse bias.

'n Oneindige lesing dui aan dat die diode teenvoorgespan is. (5)

A low or infinite reading in both conditions indicate a faulty condition of the diode.

'n Lae of oneindige lesing in beide omstandighede dui 'n foutiewe toestand van die diode aan.

11.3 Examiner must use his/her own discretion/*Nasiener moet hier sy eie diskresie volg.*

(1)
[12]