

**GAUTENG DEPARTMENT OF EDUCATION  
GAUTENGSE DEPARTEMENT VAN ONDERWYS  
SENIOR CERTIFICATE EXAMINATION  
SENIORSERTIFIKAAT-EKSAMEN**

**TECHNIKA (CIVIL / SIVIEL) HG**

**POSSIBLE ANSWERS / MOONTLIKE ANTWOORDE SUPP 2007**

---

**QUESTION 1 / VRAAG 1**

1.1

1.1.1 The collector must face north at a 35 to 40 degree angle.

*Die sonkollektor moet reg noord wys teen ? hoek van 35 tot 40 grade.*

1.1.2 Only use an SABS-approved collector.

*Gebruik net ? kollektor wat SABS-goedgekeur is.*

1.1.3 The primary circulation pipes must be kept as short as possible without affecting the pressure.

*Die primêre sirkulasiepype moet so kort moontlik wees son der om die drukhoogte te beïnvloed.*

1.1.4 To prevent heat loss, isolate the primary pipes.

*Isoleer die primêre sirkulasiepype om hitteverlies te voorkom.*

1.1.5 The collector should never be in the shade.

*Die sonkollektor moet nie in die skaduwee wees nie.*

1.1.6 The glass panel must be kept clean.

*Die glaspaneel moet skoon gehou word.*

1.1.7 In municipal areas, the cold water supply to the storage tank must have a pressure relief valve.

*In munisipale gebiede moet die koue watertoevoer deur middel van 'n drukverminderingsklep aan die opgaarsilinder voorsien word.*

**ANY FIVE ONE MARK EACH / ENIGE VYF EEN PUNT ELK**

1.2

**Pressure reducing valve**

***Drukverminderingsklep***

It reduces the water pressure from the municipal water supply to enable water to flow into the geyser if there is an outflow of hot water.

*Dit verminder die waterdruk van die munisipale watertoevoer sodat die kouewater net by die geiser inloop as die warm water uitvloei.*

**TWO MARKS / TWEE PUNTE**

**Relief valve**  
**Ontlasklep**

The steam from the hot water creates pressure in the geyser which is released by means of the relief valve when it becomes too great.

*Die stoom van die warm water veroorsaak druk in die geiser wat vrygestel word deur die ontlasklep wanneer die druk te hoog word.*

**TWO MARKS / TWEE PUNTE**

**Primary flow pipe**  
**Primêre voerpyp**

The primary flow pipe conveys the hot water from the upper connection of the collector to the top of the hot water cylinder.

*Die primêre voerpyp voer die warm water vanaf die boonste verbinding na die bokant van die opgaarsilinder.*

**TWO MARKS / TWO MARKS**

1.3

1.3.1 It must be of a material that can be easily bent to any required shape.  
*Dit moet van ? materiaal wees wat maklik in die nodige vorm gebuig kan word.*

1.3.2 It must be capable of achieving this tensile strength without undue strain.  
*Dit moet in staat wees om die trekspanning te weerstaan sonder enige noemenswaardige vervorming.*

1.3.3 Its surface must be capable of developing an adequate bond between the concrete and the reinforcement to ensure that the required design tensile strength is obtained.  
*Die oppervlak van die bewapening moet in staat wees om ? verband met die beton te verseker sodat die ontwerp-trekspanning verkry kan word.*

1.3.4 A similar coefficient of thermal expansion is required to prevent unwanted stresses being developed within the member due to temperature changes.  
*Dit moet ? soortgelyke warmte-uitsettingskoëffisiënt hê om te verhoed dat onnodige spanning deur temperatuurverandering veroorsaak word.*

1.3.5 Availability at a reasonable cost which must be acceptable to the overall design and concept.  
*Dit moet vryelik, en teen billike pryse, in die handel beskikbaar wees en aanpasbaar wees by die bewapeningsontwerp.*

**ONE MARK EACH / EEN PUNT ELK**

1.4

1.4.1 Formulating the client's need in relation to local government.  
*Die formulering van die kliënt se behoeftes rakende plaaslike owerhede.*

1.4.2 In charge of the design.  
*Staan aan die hoof van die ontwerp.*

- 1.4.3 Final costing after financing has been organised.  
*Finale kosteberekening nadat finansiering gereël is.*
- 1.4.4 Preparation of plans for approval and handing them out for tendering purposes.  
*Vorbereiding van planne vir goedkeuring en uitgee daarvan vir tender-doeleindes.*
- 1.4.5 Convening meetings to discuss building plans.  
*Belê van vergaderings om bouplanne te bespreek.*
- 1.4.6 Fully in charge of the project.  
*Is ten volle in beheer van die projek.*
- 1.4.7 Keeping client up to date with progress.  
*Hou kliënt op hoogte van vordering.*
- 1.4.8 Acting as mediator between the various parties.  
*Tree as bemiddelaar op tussen die verskillende partye.*
- 1.4.9 Advising the builder concerning the building contract.  
*Gee raad oor en verleen bystand aan bouaannemer in verband met die boukontrak.*
- 1.4.10 He must fill out the certificate as soon as the contract is completed.  
*Hy moet die sertifikaat voltooi sodra die projek afgehandel is.*

### ONE MARK EACH / EEN PUNT ELK

- 1.5
- 1.5.1 Place two pegs (A and B) on a level area about 100 metres apart.  
*Plaas twee penne (A en B) op 'n redelike gelyk terrein ongeveer 100 meter uitmekaar.*
- 1.5.2 Set up the instrument in a position, so that it is the same distance from A and B.  
*Stel die instrument op in 'n posisie, sodat dit ewe ver van A en B is.*
- 1.5.3 Set the instrument level and take the readings on the rods held at A and B.  
**(The readings are a and b respectively.)**  
The difference in the readings ( $a - b$ ) will be the real height difference between A and B, even if the instrument has a collimation fault. With the distances equal, the deviation from the horizontal line on either side will be equal and in the same direction. The miscalculation is thus corrected.  
*Stel die instrument waterpas en neem lesings op die stawwe wat by A en B gehou word. **(Gestel hierdie lesings is a en b.)** Die verskil in die lesings ( $a - b$ ) sal die ware hoogteverskil tussen A en B wees, al het die instrument 'n kollimasiefout. Met die peilingsafstande ewe lank, sal die afwyking van die horisontale lyn aan weerskante ewe groot, en in dieselfde rigting wees. Hierdeur word die fout dus uitgekanselleer.*

- 1.5.4 Move the instrument and set it up close to one rod and far from the other.  
(Rod B)  
The collimation fault will now show its full effect seeing that the marked distances are not equal in length, and the miscalculations are not corrected.  
*Verskuif nou die instrument en stel dit op in ? posisie baie naby aan die een staf, en ver van die ander staf. (Staf B.)*  
*Die kollimasiefout sal nou sy volle effek toon aangesien die peilingsafstande nie ewe lank is nie en dus nie die fout uitkanselleer nie.*
- 1.5.5 After the instrument has been set level, the readings close to rod "B" are taken. (Point b!)  
*Nadat die instrument waterpas gestel is, word die lesings naby staf B, geneem. (Punt b!)*
- 1.5.6 With the help of this reading b! and the true height difference (a – b) and no miscalculation present, the reading at "A" is calculated as follows:  
**True reading on rod A (a!) = b! + (a – b)**  
*Met behulp van hierdie lesing b! en die ware hoog teverskil (a – b), word die lesing wat op "A" gelees behoort te word, en geen fout teenwoordig is nie, soos volg bereken:*  
**Ware lesing op staf A (a!) = b! + (a – b)**
- 1.5.7 Take the real reading (a!) on rod A and compare it to the true reading.  
If both readings, the true and real readings, are the same then the instrument is set.  
*Neem nou die werklike lesing (a!) op die staf by A, en vergelyk dit met die berekende of ware lesing.*  
*Indien hierdie twee lesings, die ware en die werklike lesings, ooreenstem, is die instrument ingestel.*

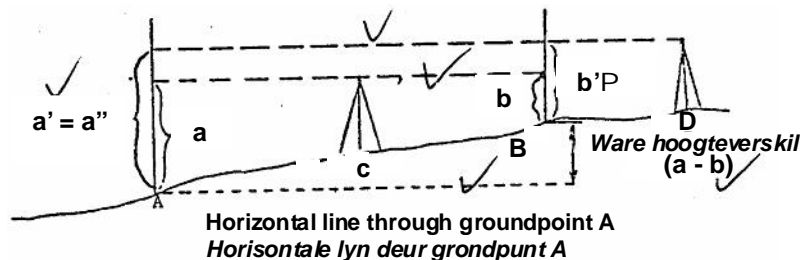

**TWO MARKS FOR EACH POINT DISCUSSED. SIX MARKS FOR THE SKETCH AS SHOWN**  
**TWEE PUNTE VIR ELKE PUNT BESKRYF. SES PUNTE VIR DIE SKETS SOOS AANGEDUI**

1.6

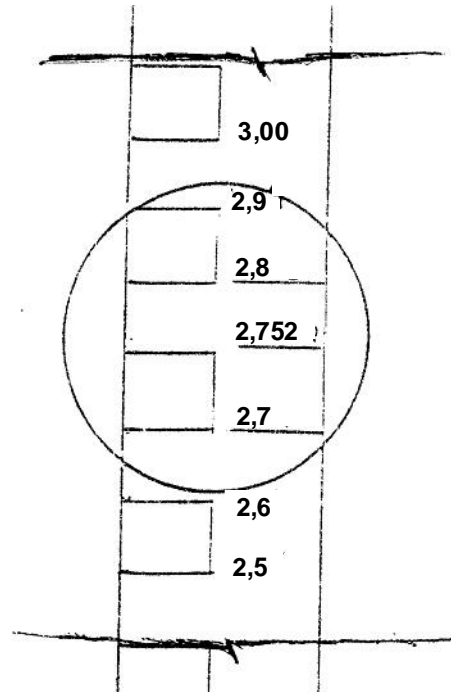
**MARKS AS SHOWN / PUNTE SOOS GETOON**

1.7

1.7.1	Cast iron	<i>Gietyster</i>
1.7.2	Bidet	<i>Bidet</i>
1.7.3	Reinforced concrete	<i>Gewapende beton</i>
1.7.4	Grease (fat) trap	<i>Vetvanger</i>
1.7.5	Soil water pipes	<i>Drekwaterype</i>

**ONE MARK EACH / EEN PUNT ELK**

1.8

Concrete pressure test  
*Betondruktoets*  
 Slump test  
*Saktoets*

**TWO MARKS EACH / TWEE PUNTE ELK****[60]**

**QUESTION 2 / VRAAG 2****CALCULATE P / BEREKEN P**

Take moments about Q

*Neem momente om Q*

$$\text{ROM} = \text{LOM}$$

$$(P \times 6) + (E \times 2) = (C \times 3) + (B \times 4)$$

$$(P \times 6) + (2 \times 2) = (3 \times 2) + (2 \times 4)$$

$$6P + 4 = 6 + 8$$

$$6P = 14 - 4$$

$$P = \frac{10}{6}$$

$$P = 1,66 \text{ kN}$$

**CALCULATE Q / BEREKEN Q**

Take moments about P

*Neem momente om P*

$$\text{ROM} = \text{LOM}$$

$$Q \times 6 = (B \times 2) + (C \times 4) + (D \times 6) + (E \times 8)$$

$$6Q = (2 \times 2) + (3 \times 4) + (4 \times 6) + (2 \times 8)$$

$$6Q = 4 + 12 + 24 + 16$$

$$Q = \frac{56}{6}$$

$$Q = 9,33 \text{ kN}$$

**TEST / TOETS**

Upward forces = Downward forces

*Opwaartse kragte = Afwaartse kragte*

$$1,66 \text{ kN} + 9,33 \text{ kN} = 2 \text{ kN} + 3 \text{ kN} + 4 \text{ kN} + 2 \text{ kN}$$

$$11 \text{ kN} = 11 \text{ kN}$$

<b>MEMBER ONDERDEEL</b>	<b>NATURE AARD</b>	<b>MAGNITUDE GROOTTE</b>
AG	STRUT / STUT	2 kN
BH	STRUT / STUT	1,1 kN
CK	STRUT / STUT	1,1 kN
DM	TIE / STANG	4,4 kN
EM	STRUT / STUT	3,8 kN
FG	TIE / STANG	0,9 kN
FJ	TIE / STANG	0,9 kN
FL	STRUT / STUT	3,8 kN
GH	TIE / STANG	0,3 kN
HJ	STRUT / STUT	0,3 kN
JK	STRUT / STUT	2,8 kN
KL	STRUT / STUT	5,6 kN
LM	STRUT / STUT	9.5 kN

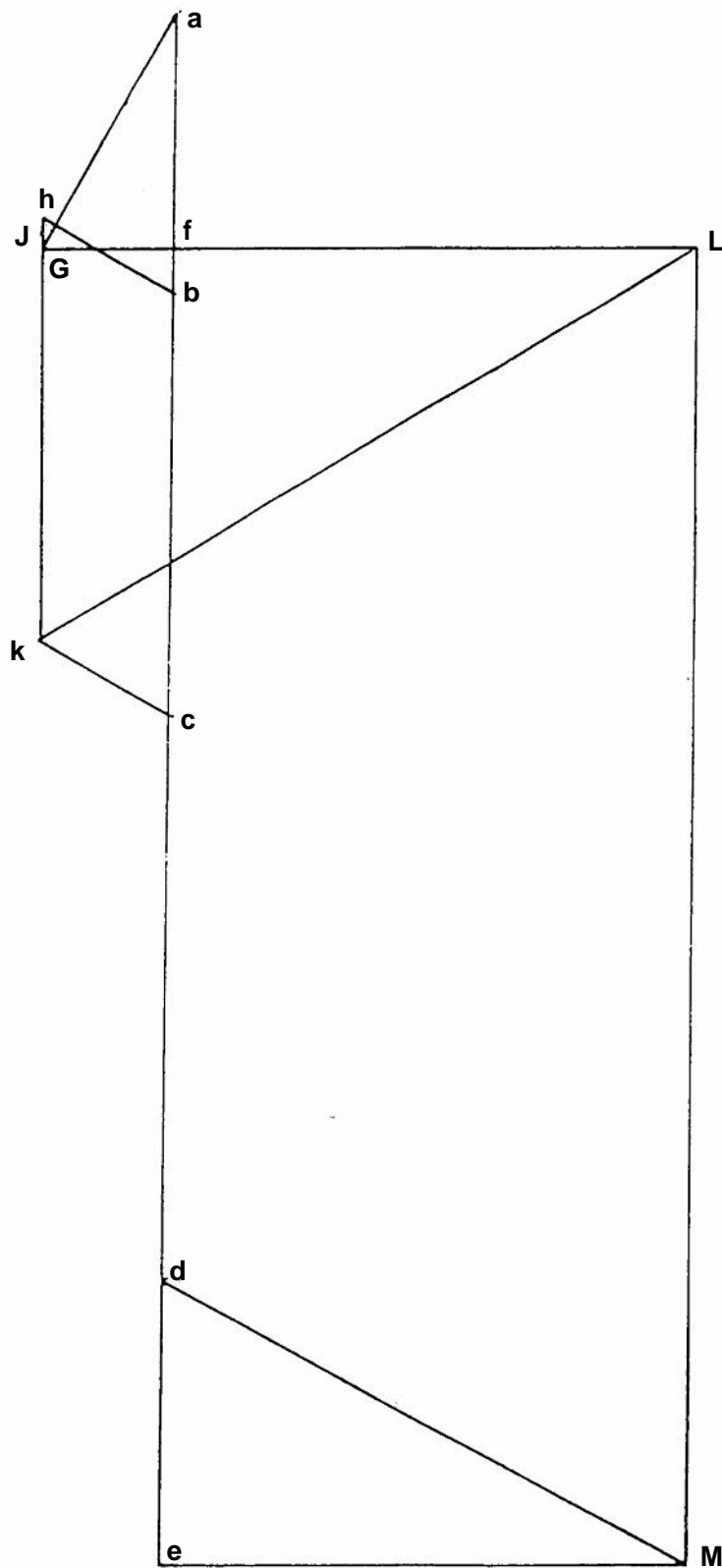

**QUESTION 3 / VRAAG 3****CALCULATE P / BEREKEN P**

Take moments about Q

*Neem momente om Q*

$$\text{ROM} = \text{LOM}$$

$$P \times 8 = (D \times 2) + (C \times 4) + (B \times 6) + (A \times 8)$$

$$8P = (4 \times 2) + (8 \times 4) + (3 \times 6) + (2 \times 8)$$

$$8P = 8 + 32 + 18 + 16$$

$$8P = 74$$

$$P = \frac{74}{8}$$

$$P = 9,25 \text{ kN}$$

**CALCULATE Q / BEREKEN Q**

Take moments about P

*Neem momente om P*

$$\text{ROM} = \text{LOM}$$

$$Q \times 8 = (A \times 0) + (B \times 2) + (C \times 8) + (D \times 6)$$

$$8Q = (2 \times 0) + (3 \times 2) + (8 \times 4) + (4 \times 6)$$

$$8Q = 0 + 6 + 32 + 24$$

$$8Q = 62$$

$$Q = \frac{62}{8}$$

$$Q = 7,75 \text{ kN}$$

**TEST / TOETS**

$$\text{Upward forces} = \text{Downward forces}$$

$$\text{Opwaartse kragte} = \text{Afwaartse kragte}$$

$$9,25 \text{ kN} + 7,75 \text{ kN} = 2 \text{ kN} + 3 \text{ kN} + 8 \text{ kN} + 4 \text{ kN}$$

$$17 \text{ kN} = 17 \text{ kN}$$

**CALCULATE BENDING MOMENTS****BEREKEN BUIGMOMENTE**

$$\text{BMA} = (P \times 0) \quad \text{BMB} = (P \times 2) - (A \times 2)$$

$$= 9,25 \times 0 = (9,25 \times 2) - (2 \times 2)$$

$$= 0 \text{ kN/m} = 18,5 - 4$$

$$= 14,5 \text{ kN/m}$$



$$\begin{aligned}
 \text{BMC} &= (P \times 4) - (R \times 1) - (B \times 2) - (A \times 4) \\
 &= (9,25 \times 4) - (4 \times 1) - (3 \times 2) - (2 \times 4) \\
 &= 37 - 4 - 6 - 8 \\
 &= \mathbf{19 \text{ kN/m}}
 \end{aligned}$$

$$\begin{aligned}
 \text{BMD} &= (P \times 6) - (C \times 2) - (B \times 4) - (A \times 6) \\
 &= (9,25 \times 6) - (8 \times 2) - (3 \times 4) - (2 \times 6) \\
 &= 55,5 - 16 - 12 - 12 \\
 &= \mathbf{15,5 \text{ kN/m}}
 \end{aligned}$$

$$\begin{aligned}
 \text{BME} &= (P \times 8) - (D \times 2) - (C \times 4) - (B \times 6) - (A \times 8) \\
 &= (9,25 \times 8) - (4 \times 2) - (8 \times 4) - (3 \times 6) - (2 \times 8) \\
 &= 74 - 8 - 32 - 18 - 16 \\
 &= \mathbf{0 \text{ kN/m}}
 \end{aligned}$$

**CALCULATE SHEAR FORCES****BEREKEN SKUIFKRAGTE**

$$\begin{aligned}
 \text{SFA / SKA} &= P - A = 9,25 - 2 = \mathbf{7,25 \text{ kN}} \\
 \text{SFB- / SKB} &= P - A = 9,25 - 2 = \mathbf{7,25 \text{ kN}} \\
 \text{SFB+ / SKB+} &= P - A - B = 9,25 - 2 - 3 = \mathbf{4,25 \text{ kN}} \\
 \text{SFC / SKC} &= P - A - B - R = 9,25 - 2 - 3 - 4 = \mathbf{0,25 \text{ kN}} \\
 \text{SFD- / SKD-} &= P - A - B - C = 9,25 - 2 - 3 - 8 = \mathbf{-3,75 \text{ kN}} \\
 \text{SFD+ / SKD+} &= P - A - B - C - D = 9,25 - 2 - 3 - 8 - 4 = \mathbf{-7,75 \text{ kN}} \\
 \text{SFE- / SKE-} &= P - A - B - C - D = 9,25 - 2 - 3 - 8 - 4 = \mathbf{-7,75 \text{ kN}} \\
 \text{SFE+ / SKE+} &= P - A - B - C - D + Q = 9,25 - 2 - 3 - 8 - 4 + 7,75 = \mathbf{0 \text{ kN}}
 \end{aligned}$$

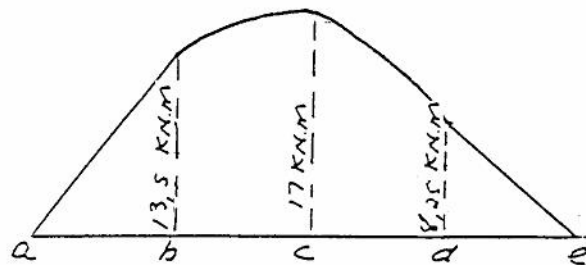
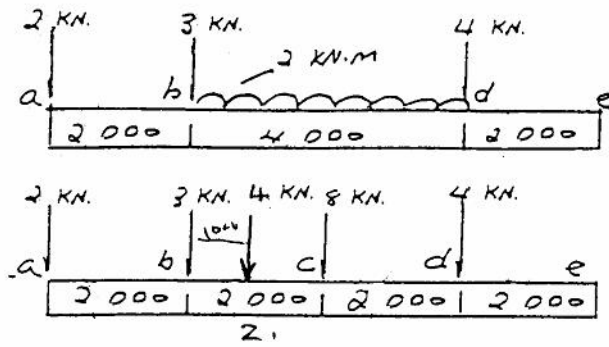

SKAAL/SCALE  
 2MM = 1KN.M

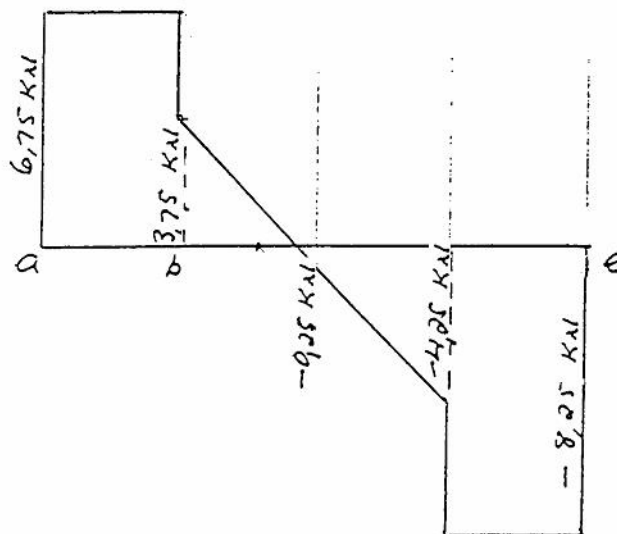

SKAAL/SCALE  
 5MM = 1KN

MARKS AS SHOWN / PUNTE SOOS AANGEDUI

[60]

## QUESTION 4 / VRAAG 4

**DWELLING PLAN****HUISPLAN****NORTH ELEVATION****NOORD-AANSIG**

DETERMINING OF ROOF HEIGHT	6	BEPALING VAN DAKHOOGTE
SUBSTRUCTURE	2	ONDERBOU
SUPERSTRUCTURE	2	BOBOU
GUTTER	2	GEUT
FASCIA BOARD	2	FASSIEPLANK
DOWNPIPES	2	AFLEIPYPE
OVERHANG	2	OORHANG
WINDOW PLACEMENT	2	VENSTERPLASING
WINDOW OPENERS	2	VENSTEROOPMAKERS
WINDOW SILL	2	VENSTERBANK
ROOF CONSTRUCTION	4	DAKKONSTRUKSIE
RIDGE CAP	2	NOKPLAAT
SCALE	2	SKAAL
NEATNESS	<u>2</u>	NETHEID
	<b>34</b>	

**EAST ELEVATION****OOS-AANSIG**

SUBSTRUCTURE	2	ONDERBOU
SUPERSTRUCTURE	2	BOBOU
ROOF CONSTRUCTION	4	DAKKONSTRUKSIE
RIDGE CAP	2	NOKPLAAT
FASCIA BOARD	2	FASSIEPLANK
GUTTER	2	GEUT
DOWNPIPES	2	AFLEIPYPE
DOOR	2	DEUR
WINDOW PLACING	2	VENSTERPLASING
WINDOW SILL	2	VENSTERBANK
LABELS	2	BYSKRIFTE
SCALE	<u>2</u>	SKAAL
	<b>26</b>	

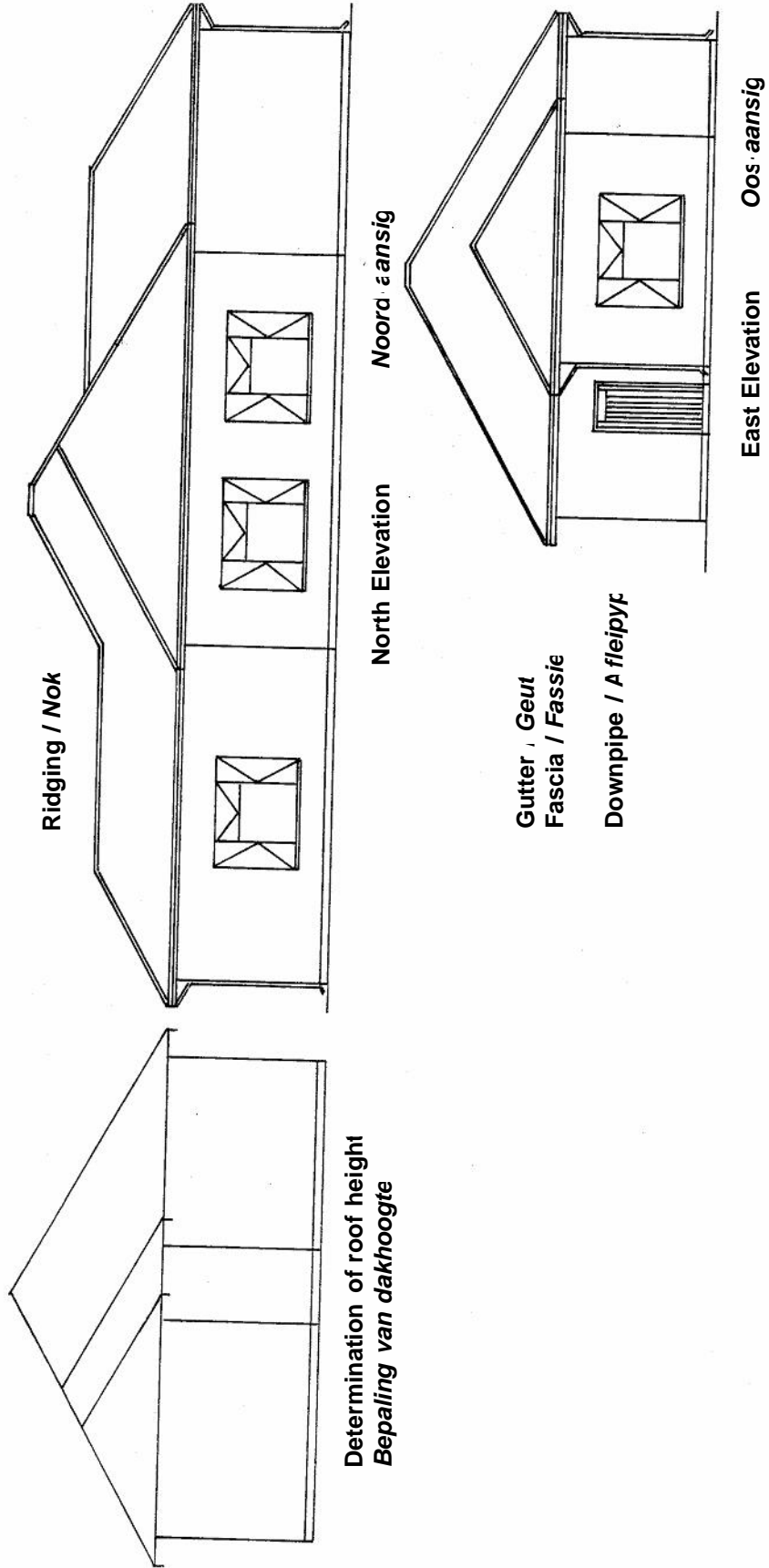

Scale / Skaal 1:1

## QUESTION 5 / VRAAG 5

5.1

**SECTION THROUGH A–A**

Section through beam and column	4
Main bars correctly placed	2
Anchors placed correctly	2
Shear reinforcement placed correctly	2
Spacing of stirrups	4
Main bars in columns	2
Stirrups in column	2
Labels	2
Neatness	2
Line work	2
Scale	<u>2</u>
	<b>26</b>

**SNIT DEUR A–A**

<i>Lengtesnit deur balk en kolom</i>
<i>Hoofstawe korrek geplaas</i>
<i>Ankerstawe korrek geplaas</i>
<i>Skuifwapening korrek geplaas</i>
<i>Spasiëring van beuels</i>
<i>Hoofstawe by kolomme</i>
<i>Beuels by kolomme</i>
<i>Byskrifte</i>
<i>Netheid</i>
<i>Lynwerk</i>
<i>Skaal</i>

5.2

**SECTION THROUGH B–B**

Cross-section B – B correct	1
Main bars correctly placed	2
Shear reinforcement placed correctly	2
Anchor placed correctly	1
Stirrups correctly placed	2
Labels	2
Neatness and line work	2
Scale	<u>1</u>
	<b>13</b>

**SNIT DEUR B–B**

<i>Dwarsnit B – B korrek</i>
<i>Hoofwapening korrek getoon</i>
<i>Skuifwapening korrek geplaas</i>
<i>Ankerstaaf korrek getoon</i>
<i>Beuels korrek</i>
<i>Byskrifte</i>
<i>Netheid en lynwerk</i>
<i>Skaal</i>

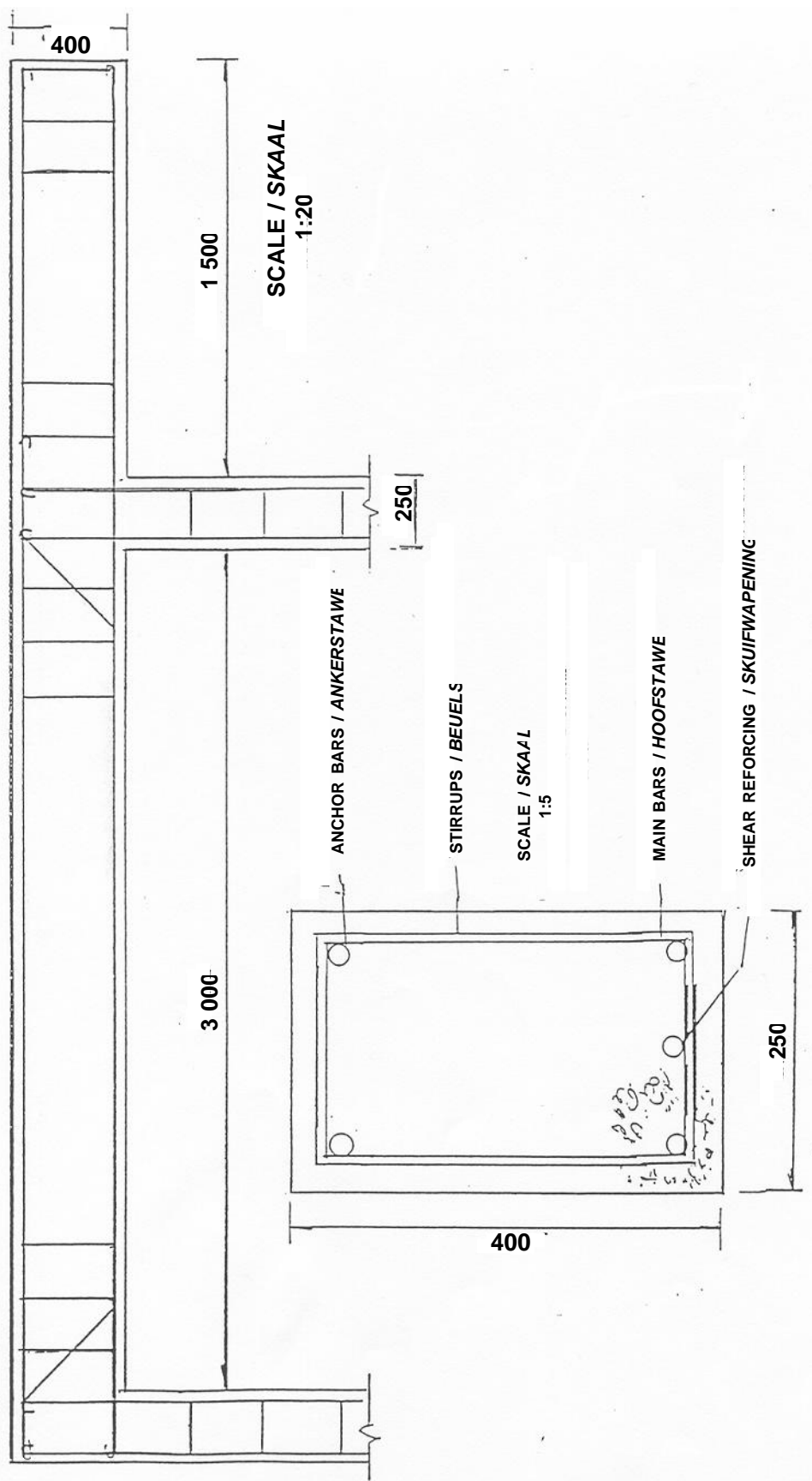

MARKS AS SHOWN / PUNTE SOOS AANGEDUI

## 5.3

5.3.1 Bars must, where possible, be bent while cold.

*Stawe moet waar moontlik koud gebuig word.*

5.3.2 Bars which are dependent on cold bending for their strength must never be heated.

*Stawe wat vir hul sterkte van koudbewerking afhanklik is, moet nooit warm gemaak word nie.*

5.3.3 Bars which have to be bent while hot must never be heated more than 850 degrees Celcius.

*Stawe wat warm gebuig moet word, moet nooit warmer as 850 grade Celcius gemaak word nie.*

5.3.4 Bars must only be bent once into the required form.

*Stawe moet slegs een maal in die verlangde vorm gebuig word.*

**TWO MARKS EACH / TWEE PUNTE ELK**

## 5.4

5.4.1 To cope with the tensile strength in the concrete.

*Om die trekspanning in beton te dra.*

5.4.2 To eliminate the shear force which occurs at the supports.

*Om die skuifspanning wat by die steunpunte voorkom, te elimineer.*

5.4.3 To increase the compressive strength of the concrete.

*Om die drukspanning wat beton kan weerstaan, te verhoog.*

5.4.4 To limit cracks that occur during the curing period.

*Om barste wat as gevolg van krimping voorkom, te beperk.*

**TWO MARKS EACH / TWEE PUNTE ELK**

## 5.5

9 = Total number of bars in group

12 = Diameter in mm

01 = Bar mark number

300 = Spacing centre to centre

R = Mild steel round bar

9 = Aantal stawe in groep

12 = Deursnee in mm

01 = Staafnommer

300 = Hart-op-hart-spasiëring

R = Sagte staal rondestaaf

**ONE MARK EACH / EEN PUNT ELK**

**[60]**

## QUESTION 6 / VRAAG 6

6.1

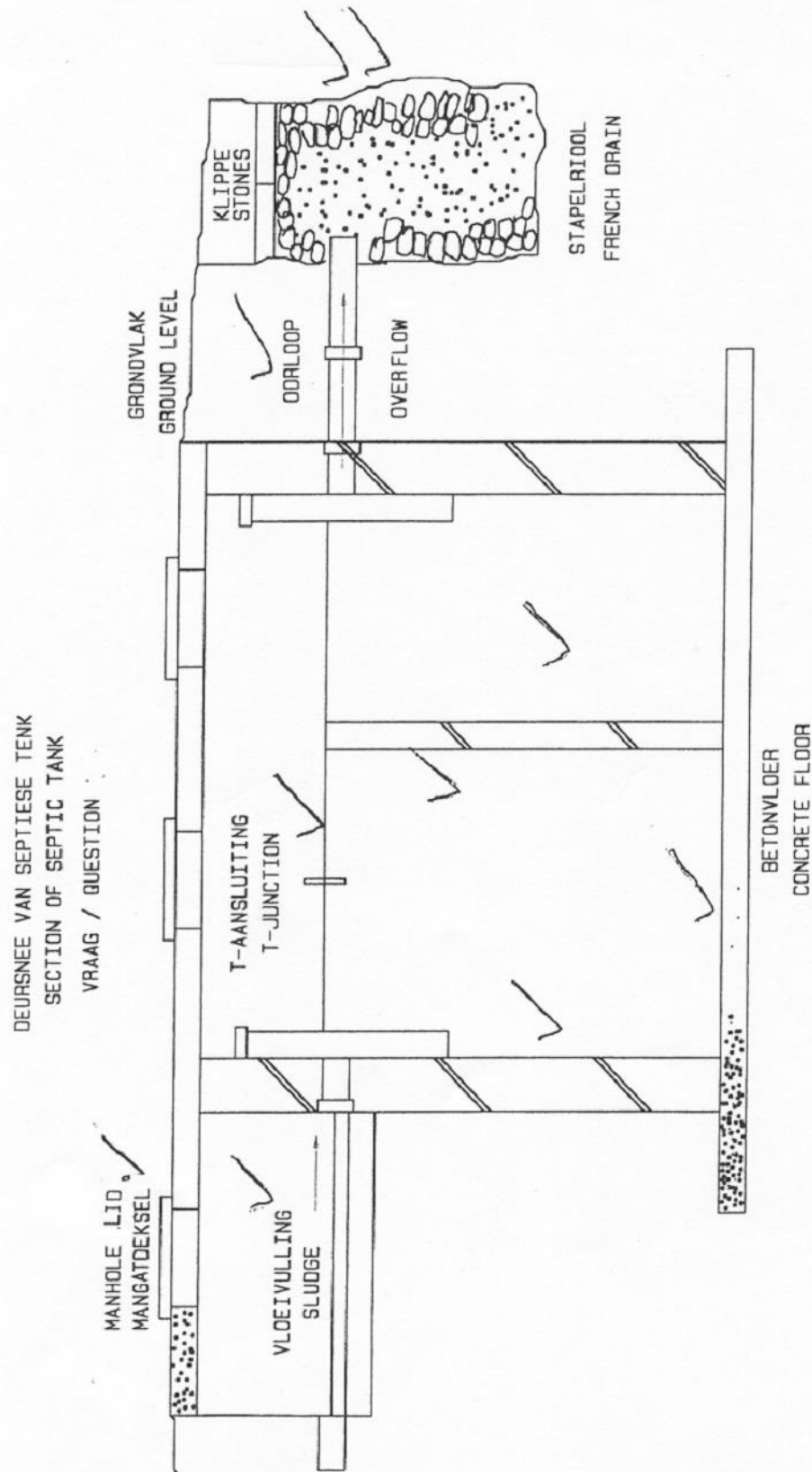

TWO MARKS PER TICK / TWE PUNTE PER REGMERK



## 6.2

**BASEMENT CONSTRUCTION**

DISTANCE BELOW GROUND	2
CONCRETE FLOOR (100 mm)	2
ONE-AND-A-HALF BRICK WALL	4
CONCRETE FOUNDATION	2
GROUND LEVEL	2
SAND BLINDING (50 mm)	1
VERTICAL AND HORIZONTAL DAMP-PROOFING	6
PLASTER INNER WALL	1
	<b>20</b>

***KELDERVERDIEPING***

<i>AFSTAND ONDER GROND</i>
<i>BETONVLOER (100 mm)</i>
<i>EEN-EN-'N-HALFSTEEN-MUUR</i>
<i>BETONFONDASIE</i>
<i>GRONDLAAG</i>
<i>SANDSLYTLAAG (50 mm)</i>
<i>VERTIKALE EN HORIZONTAL</i> <i>VOGWEERLAE</i>
<i>PLEISTER AAN BINNEMUUR</i>

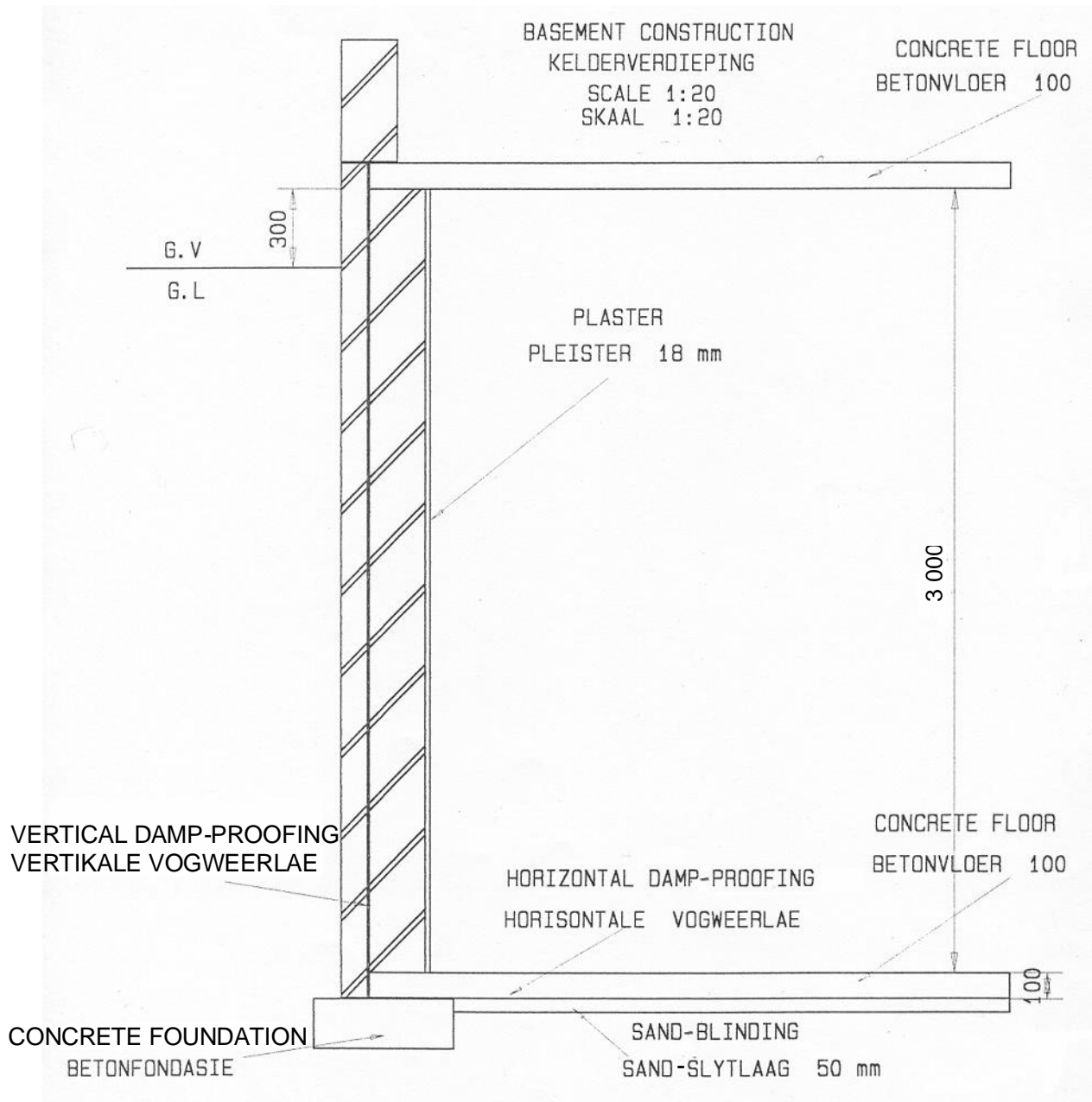

6.3

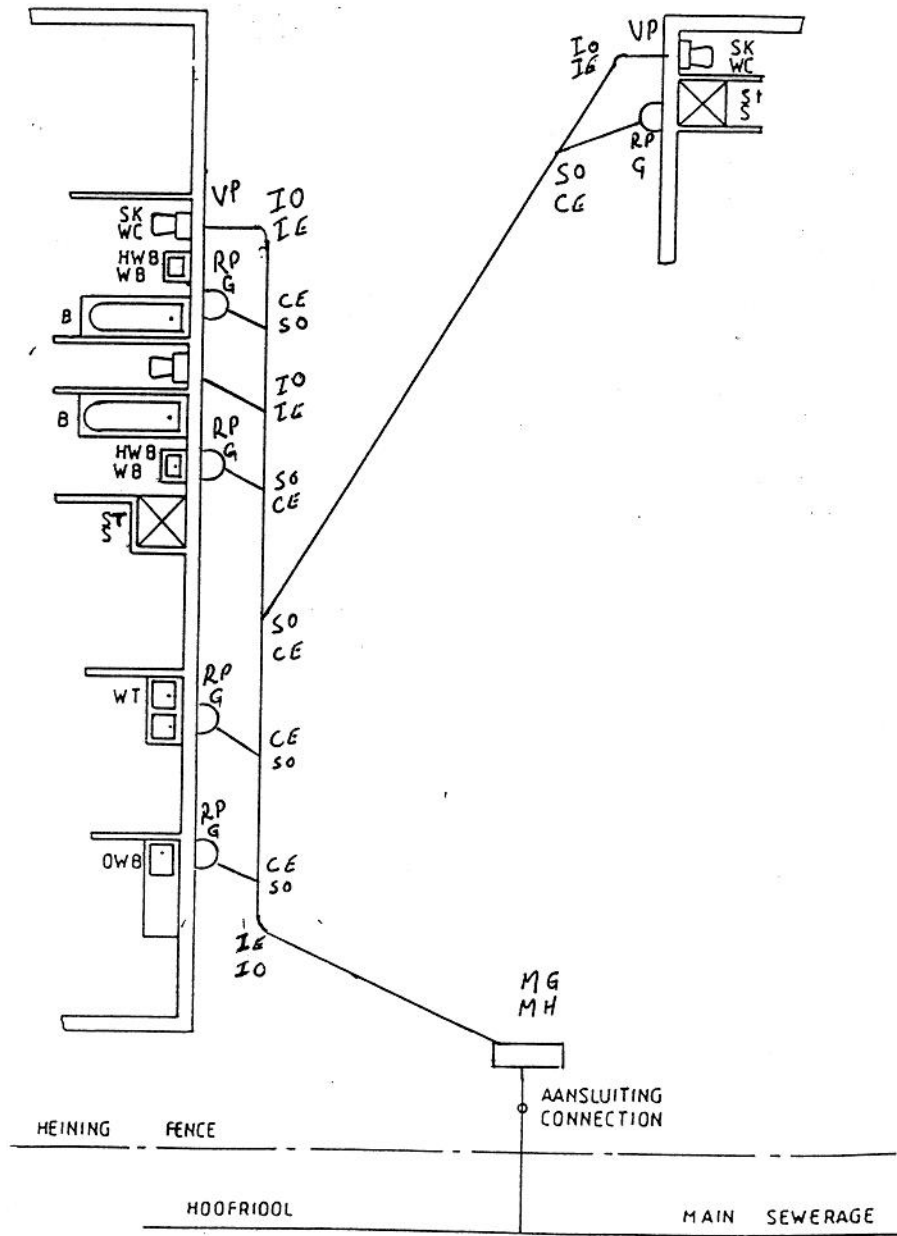

MARKS AS SHOWN / PUNTE SOOS AANGEDU

[60]

## QUESTION 7 / VRAAG 7

## CONCRETE BEAM AND FLOOR

BEAM	6
FLOOR	6
SOFFIT BOARDS	4
JOISTS 114 x 76 mm	4
CLEATS 76 x 50 mm	2
HEAD TREE 76 x 50 mm	2
STRUT 114 x 76 mm	2
STRUTS 76 mm x 22 mm	2
FISH PLATES	2
SOLE PLATE	2
WEDGES	2
FIXING PLATES	2
EXTRA STRUTS	2
BEAM REINFORCING	6
SLAB REINFORCING	6
DIMENSIONS	3
LABELS	3
SCALE	4
	<b>60</b>

*BETONBALK EN-VLOER*

<i>BALK</i>
<i>VLOER</i>
<i>SOFFIETPLANKE</i>
<i>BALKE 114 x 76 mm</i>
<i>KLAMPE 76 x 50 mm</i>
<i>KOPDRAER 76 x 50 mm</i>
<i>STUT 114 x 76 mm</i>
<i>STUTTE 76 mm x 22 mm</i>
<i>SPALKPLATE</i>
<i>VOETPLAAT</i>
<i>WIGPAAR</i>
<i>HEGSTROKE</i>
<i>EKSTRA STUTTE</i>
<i>BAL KWAPENING</i>
<i>BLADWAPENING</i>
<i>AFMETINGS</i>
<i>BYSKRIFTE</i>
<i>SKAAL</i>

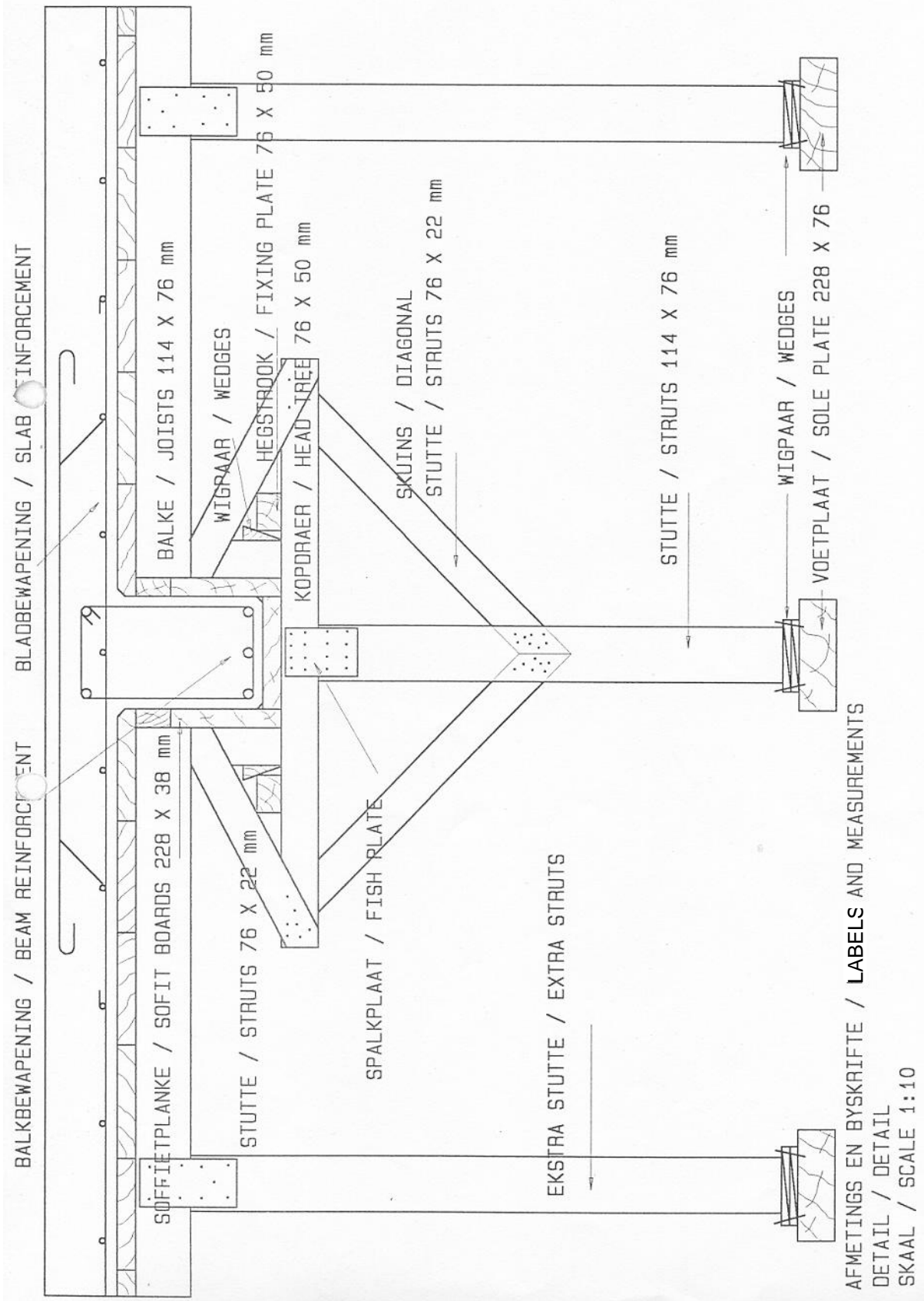

MARKS AS SHOWN / PUNTE SOOS AANGEDUI

[60]

TOTAL / TOTAAL:

300