

GAUTENG DEPARTMENT OF EDUCATION
GAUTENG DEPARTEMENT VAN ONDERWYS

EXAMINATION NUMBER / EKSAMENNOMMER

--	--	--	--	--	--	--	--	--	--	--	--

SENIOR CERTIFICATE EXAMINATION
SENIORSERTIFIKAAT-EKSAMEN

REQUIREMENTS:

- Drawing equipment

INSTRUCTIONS:

- Answer ALL questions on the answer sheets provided.
- Write your examination number on EACH answer sheet.
- Approximate any dimensions not given.
- At the end of the session, all answer sheets must be stapled together at the TOP LEFT-HAND corner in the correct sequence.
- All unused answer sheets must be handed in.

BENODIGHEDE:

- Tekeninstrumente

INSTRUKSIES:

- Beantwoord ALLE vrae op die gegewe antwoordvelle.
- Skryf jou eksamennummer op ELKE antwoordvel.
- Benader enige afmetings wat nie gegee is nie.
- Aan die einde van die sessie moet AL die antwoordvelle in die korrekte numeriese volgorde in die BOONSTE LINKERKANTSTE hoek vasgekram word.
- Alle ongebruikte antwoordvelle moet ingehandig word.

TECHNICAL DRAWING SG
TEGNIIESE TEKENE SG

SECOND PAPER / TWEDE VRAESTEL
DRAWING BOOK / TEKENEBOEK

TIME: 3 Hours / TYD: 3 Ure
MARKS: 150 / PUNTE: 150

711-2/2 U

6 PAGES / 6 BLADSYE

QUESTION VRAAG	MARKS PUNTE	INITIAL PARAFEER
1.		
2.		
3.		
4.		
TOTAL TOTAAL		
CONTROLLER KONTROLEERDER		

QUESTION 1

The given figure shows an isometric view of a casting. Draw to a scale of 1:1 and in third-angle orthographic projection the following views of the casting:

- 1.1 A front view as seen in the direction of the arrow
- 1.2 A left view
- 1.3 A top view
- 1.4 Indicate the projection symbol representing third-angle orthographic projection in the space provided.

ALL hidden detail must be shown.
No dimensions are required.

VRAAG 1

Die gegewe figuur toon 'n isometriese aansig van 'n gietstuk. Teken volgens 'n skaal van 1:1 en in derdehoekse ortografiese projeksie die volgende aansigte van die gietstuk:

- 1.1 'n Vooraansig vanuit die rigting wat deur die pyl aangedui word
- 1.2 'n Linkeraansig
- 1.3 'n Boaansig
- 1.4 Toon die projeksiesimbool vir derdehoekse ortografiese projeksie in die ruimte wat daarvoor voorsien word.

ALLE verborge detail moet getoon word.
Geen afmetings word vereis nie.

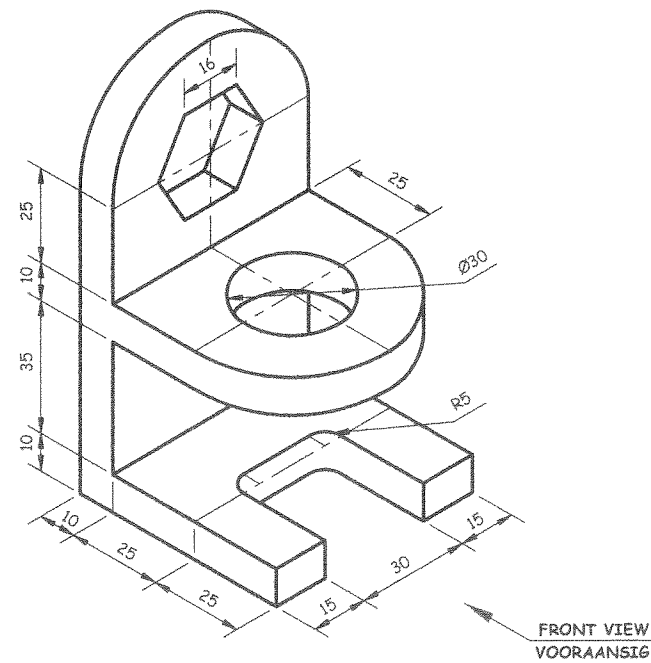

SYMBOL / SIMBOOL

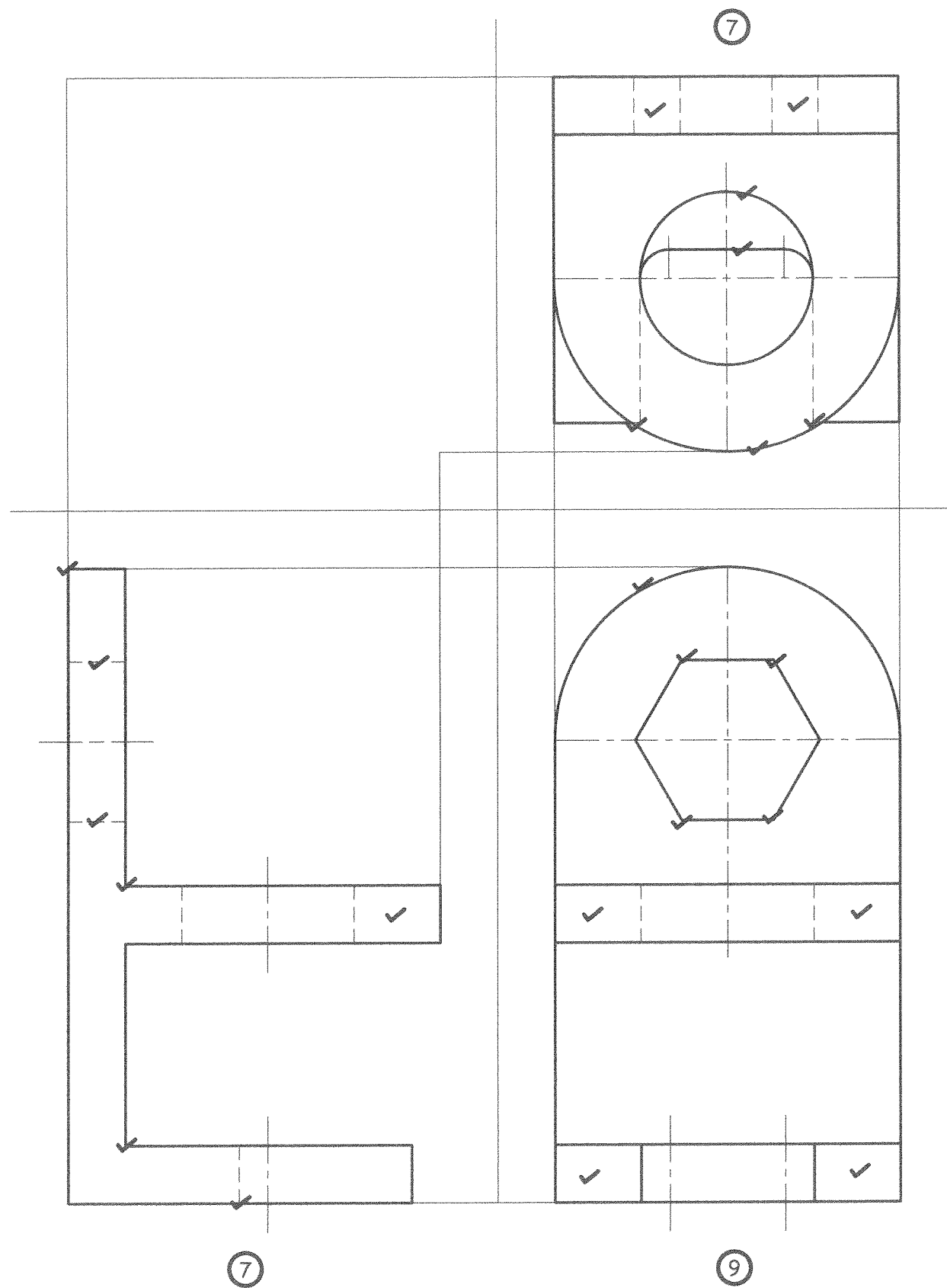
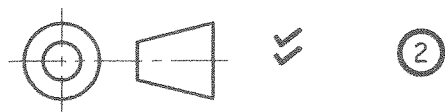

Placing Plasing	-3		
Presentation Aanbieding	-2		
Front view Vooraansig	9		
Top view Bo-aansig	7		
Left view Linkeraansig	7		
Symbol Simbool	2		
TOTAL TOTAAL	25		

EXAMINATION NUMBER:

EKSAMENNUMMER:

QUESTION 2

The given figure shows three views of a casting in first-angle orthographic projection. Draw to a scale of 1:1 a neat isometric view of the casting.

Use point A to start the drawing.

VRAAG 2

Die gegewe figuur toon drie aansigte van 'n gietstuk in eerstehoekse ortografiese projeksie. Teken volgens 'n skaal van 1:1 'n netjiese isometriese aansig van die gietstuk.

Gebruik punt A as beginpunt.

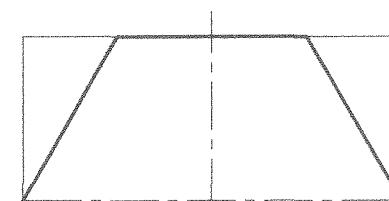
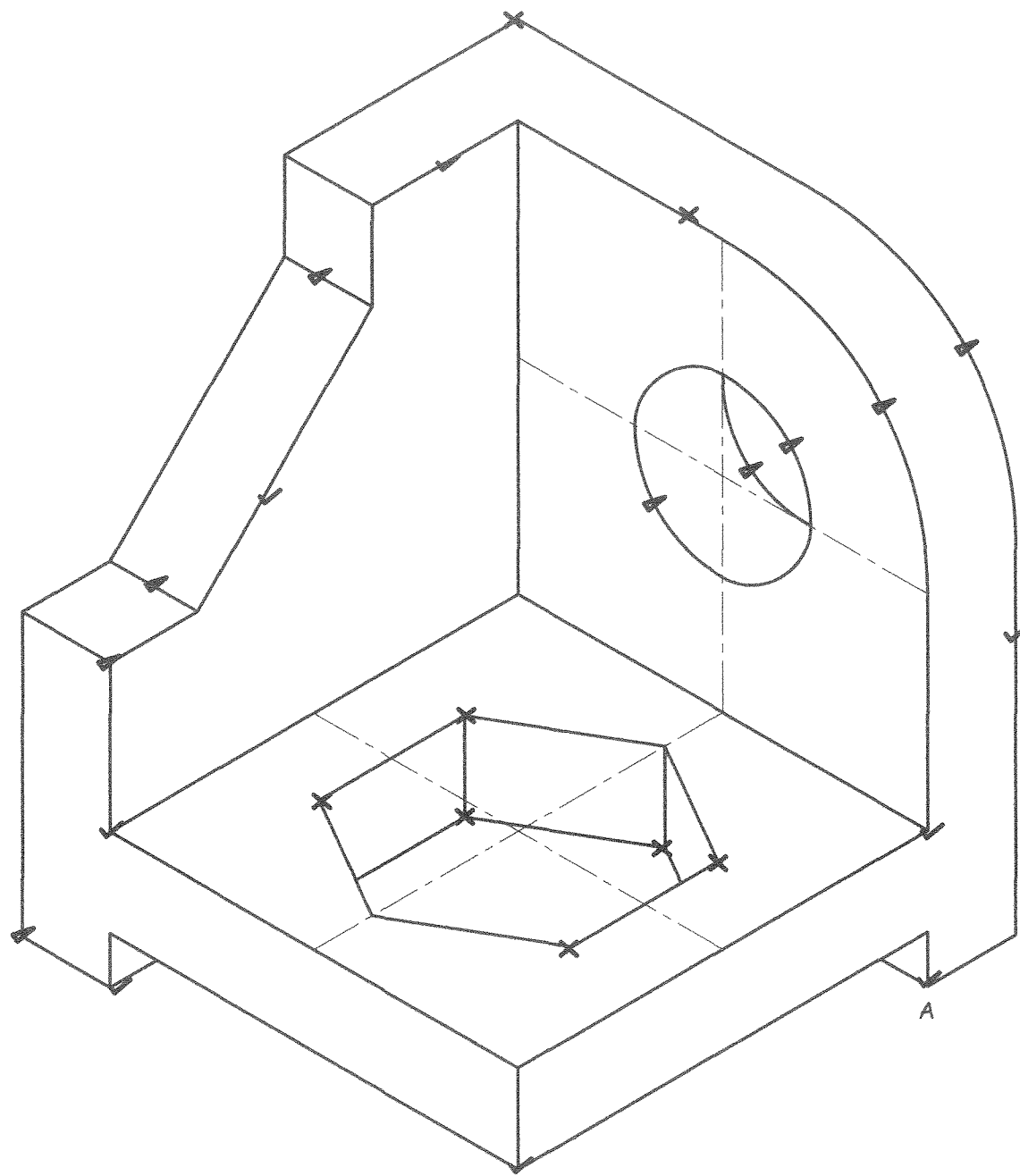
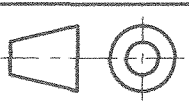
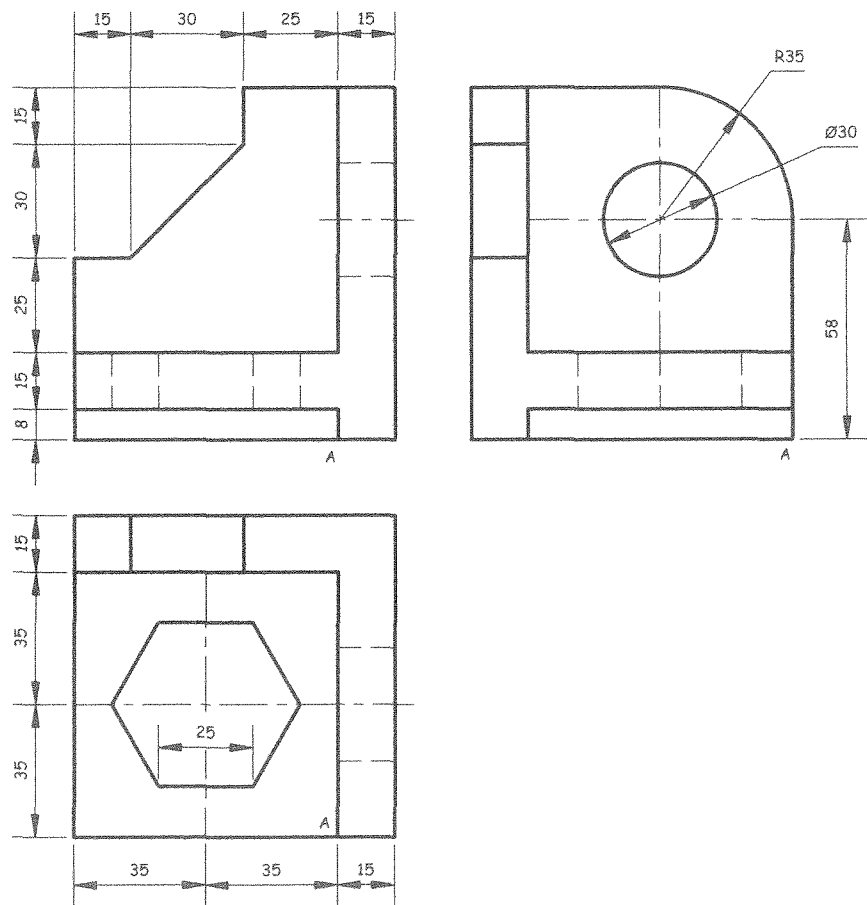

✓ Frontal plane Voorste vlak	8		
✗ Top plane Boonste vlak	8		
✓ Left plane Linkervlak	9		
Linework Lynwerk	-3		
TOTAL TOTAAL	25		

EXAMINATION NUMBER:
EKSAMENNOMMER:

--	--	--	--	--	--	--	--	--	--

TECHNICAL DRAWING STANDARD GRADE
TEGNIESE TEKENE STANDAARDGRAAD

SG 711 - 2/2 U
SG 711 - 2/2 U

ANSWER SHEET 2
ANTWOORDVEL 2

QUESTION 3

Three views of a dwelling that has been developed as part of a project of 100 low-cost houses in Mamelodi, Tswane-East, are shown. Draw a neat, two-point perspective view of the dwelling.

Ignore wall thickness.
No hidden detail is required.

VRAAG 3

Drie aansigte van 'n woning wat deel is van 'n projek van 100 laekoste-huise in Mamelodi, Tswane-Oos, word getoon. Teken 'n netjiese tweepuntperspektief-aansig van die woning.

Ignoreer muur diktes.
Geen verborge detail hoef getoon te word nie.

Perspective view Perspektief-aansig	20		
Vanishing points Verdwynpunte	2		
Presentation Aanbieding	3		
TOTAL TOTAAL	25		

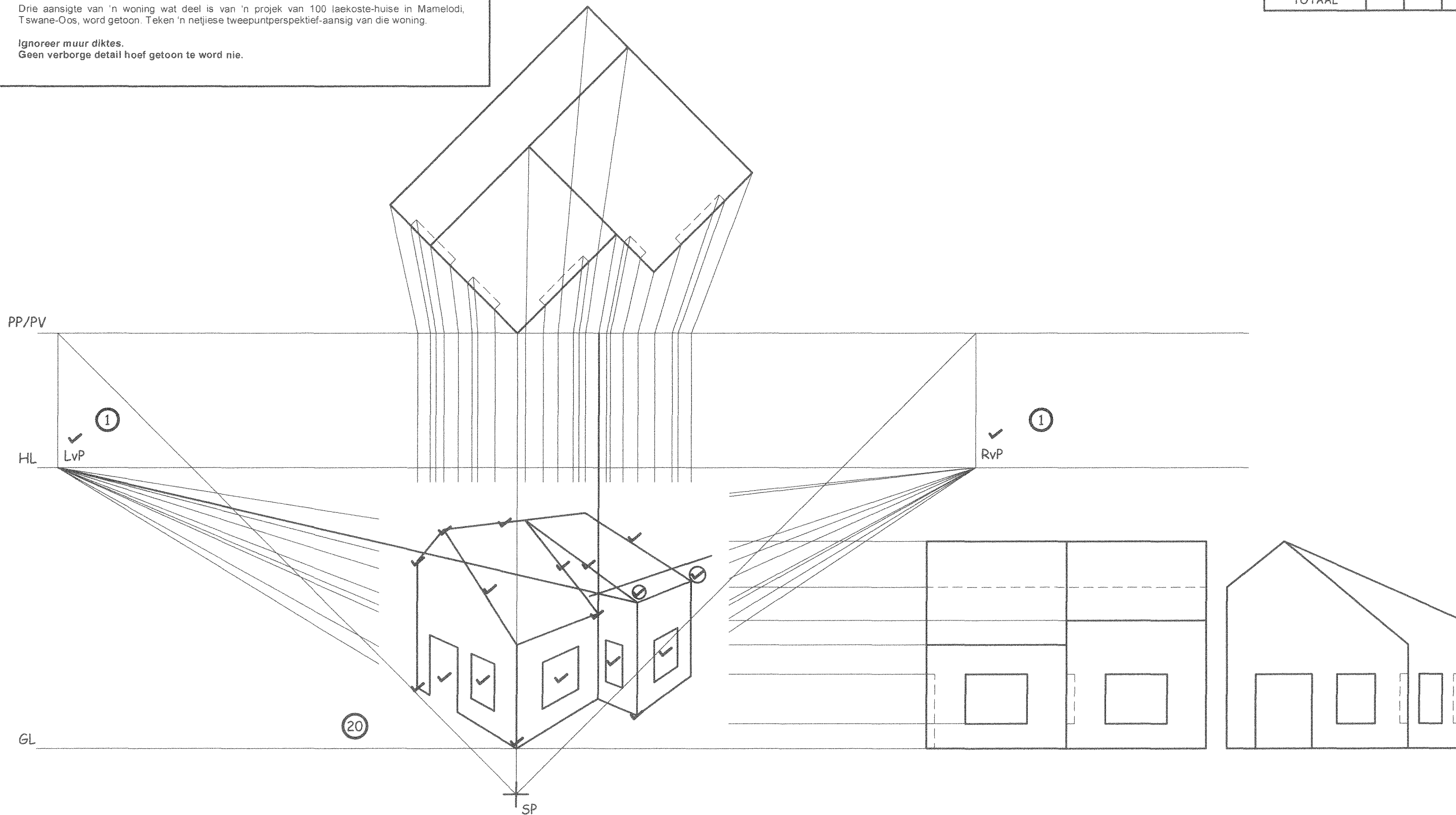

EXAMINATION NUMBER:
EKSAMENNOMMER:

--	--	--	--	--	--	--	--	--	--

TECHNICAL DRAWING STANDARD GRADE
TEGNIESE TEKENE STANDAARDGRAAD

SG 711 - 2/2 U
SG 711 - 2/2 U

ANSWER SHEET 3
ANTWOORDVEL 3

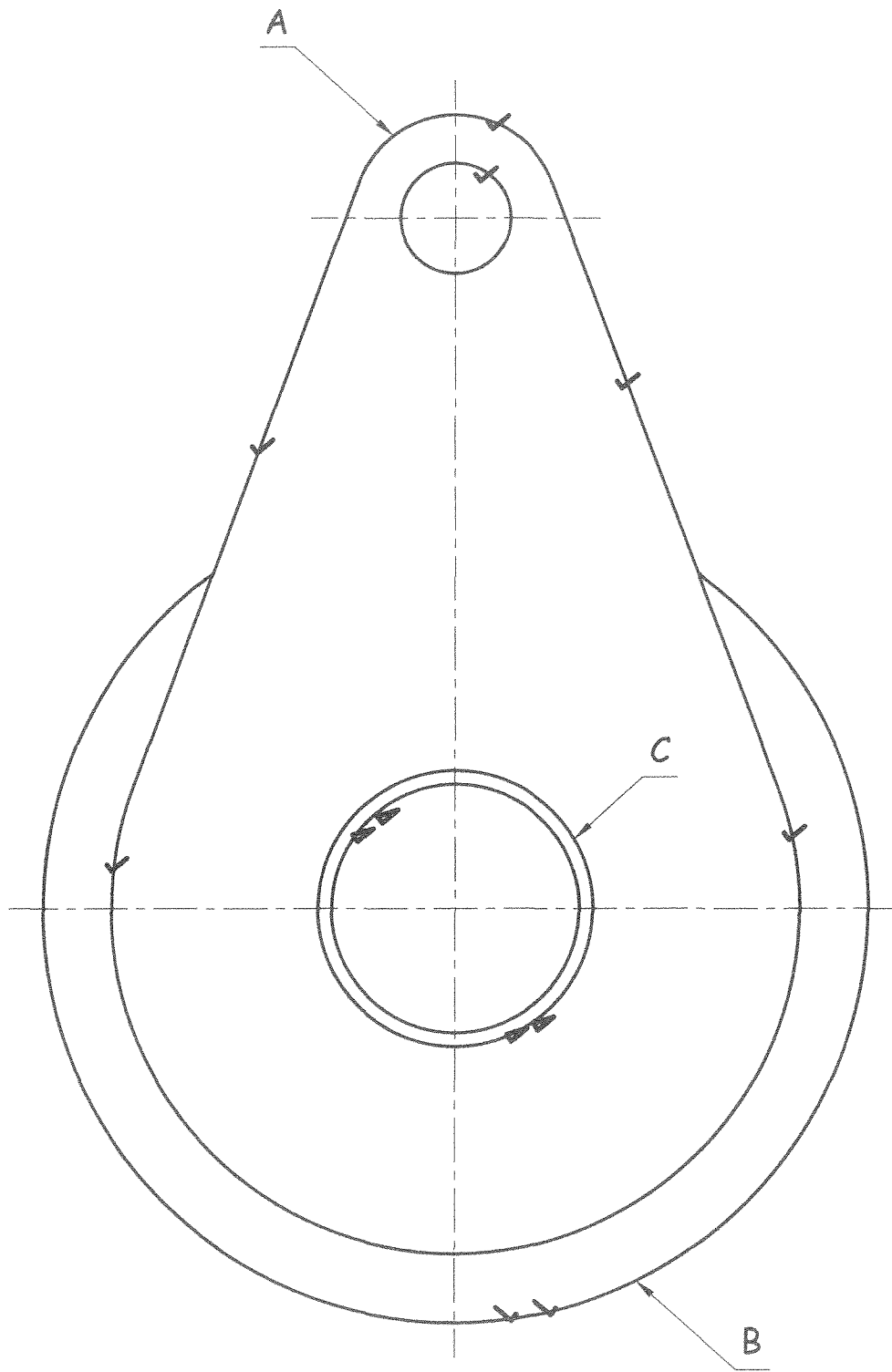
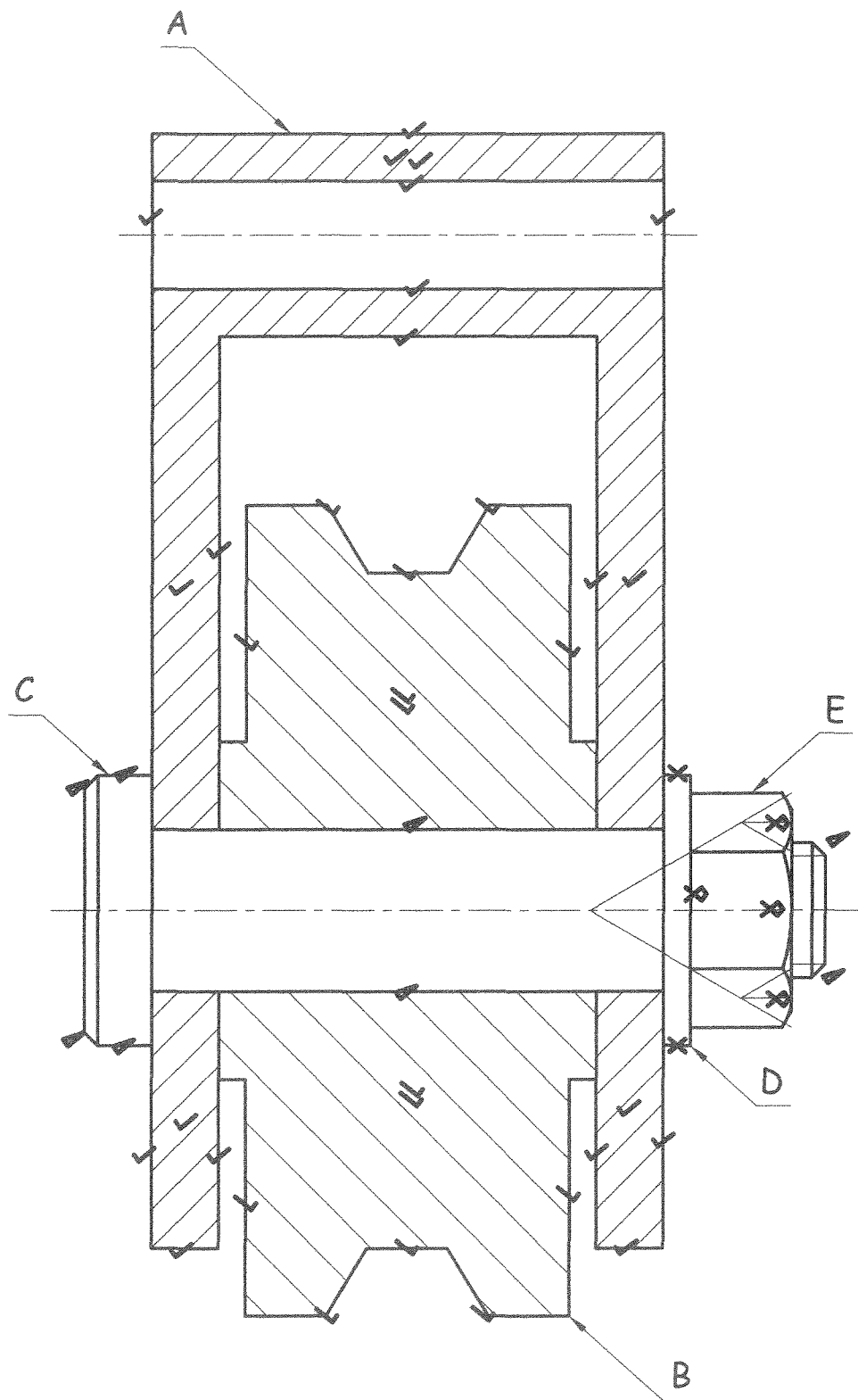

FRONT VIEW VOORAANSIG			
✓	PART A	20	
✓	PART B	14	
✓	PART C	8	
✗	PART D	2	
✗	PART E	4	
TOTAL / TOTAAL		48	
LEFT VIEW LINKER-AANSIG			
✓	PART A	6	
✓	PART B	2	
✓	PART C	4	
TOTAL / TOTAAL		12	
48 + 12 = 60		60	
ASSEMBLY SAMESTELLING		4	
DIMENSIONS AFMETINGS		3	
LINEWORK LYNWERK		4	
TITLE TITEL		2	
SYMBOL SIMBOOL		2	
TOTAL TOTAAL		75	

SYMBOL / SIMBOOL		TITLE BLOCK / TITELBLOK	
	✓	PULLEY ASSEMBLY SCALE 1:1	✓ KATROL SAMESTELLING SKAAL 1:1

EXAMINATION NUMBER:
EKSAMENNOMMER:

TECHNICAL DRAWING STANDARD GRADE
TEGNIJSE TEKENE STANDAARDGRAAD

SG 711 - 2/2 U
SG 711 - 2/2 U

ANSWER SHEET 4
ANTWOORDVEL 4