



# education

---

Department:  
Education  
**REPUBLIC OF SOUTH AFRICA**

**SENIOR CERTIFICATE EXAMINATION - 2006**

**PHYSICAL SCIENCE P1  
PHYSICS**

**STANDARD GRADE**

**OCTOBER/NOVEMBER 2006**

**MARKS: 150**

**TIME: 2 hours**

This question paper consists of 14 pages, a data sheet consisting of 2 pages, 1 multiple-choice answer sheet and 1 sheet of graph paper.

**NOTE: QUESTION 8.1 SHOULD BE ANSWERED ON THE GRAPH PAPER WHICH IS PROVIDED.**

**GENERAL INSTRUCTIONS**

1. Write your examination number (and centre number if applicable) in the appropriate spaces on the answer book.
2. Answer ALL the questions.
3. Non-programmable calculators may be used.
4. Appropriate mathematical instruments may be used.
5. A data sheet is attached for your use.
6. NOTE! The following circuit diagram symbols are used in this paper:

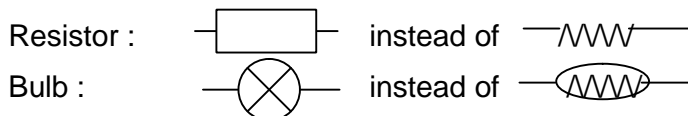

7. Marks may be forfeited if instructions are not followed.

**QUESTION 1****INSTRUCTIONS**

1. Answer this question on the specially printed ANSWER SHEET. [NOTE: The answer sheet may either be a separate sheet provided as part of your question paper, or printed as part of the answer book.] Write your EXAMINATION NUMBER (and centre number if applicable) in the appropriate spaces if a separate answer sheet is used.
2. Four possible answers, indicated by A, B, C and D, are supplied with each question. Each question has only ONE correct answer. Choose only that answer which, in your opinion, is the correct or best one and mark the appropriate block on the ANSWER SHEET with a cross (X).
3. Do NOT make any other marks on the answer sheet. Any calculations or writing that may be necessary when answering this question should be done in the answer book and must be deleted clearly by means of a diagonal line drawn across the page.
4. If more than one block is marked, no marks will be awarded for that answer.

PLACE THE COMPLETED ANSWER SHEET INSIDE THE FRONT COVER OF YOUR ANSWER BOOK, IF A SEPARATE ANSWER SHEET HAS BEEN USED.

**EXAMPLE**

**QUESTION:** The SI unit of time is ...

- A t.  
B h.  
C s.  
D m.

**ANSWER:**

A	B	<del>C</del>	D
---	---	--------------	---

[NOTE: This layout may vary, depending on the type of answer sheet used by the province.]



**QUESTION 1**

1.1 Which ONE of the following combinations of base units represents **momentum**?

A  $\text{kg}\cdot\text{m}\cdot\text{s}^{-1}$

B  $\text{kg}\cdot\text{m}\cdot\text{s}^{-2}$

C  $\text{kg}\cdot\text{m}^2\cdot\text{s}^{-2}$

D  $\text{kg}\cdot\text{m}^2\cdot\text{s}^{-3}$  (3)

1.2 In which ONE of the following cases is the distance covered and the magnitude of the displacement the same?

A A lion chases an impala through a ditch.

B A boy runs up a spiral staircase.

C An apple falls from a tree on a windless day.

D A bus travels from Butterworth to East London. (3)

1.3 John, who is standing in a lift, observes a 20 N mass piece suspended from a spring balance fixed to the roof of the lift. He sees that the reading on the spring balance is less than 20 N for a short interval.

The correct description for the motion of the lift during this short interval is that the lift is ...

A not moving.

B accelerating upwards.

C accelerating downwards.

D moving with constant velocity. (3)



- 1.4 From which ONE of the following pairs of physical quantities will it always be possible to calculate average speed?
- A Distance travelled and time taken
  - B Instantaneous speed and acceleration
  - C Acceleration and the time for the acceleration
  - D Two different instantaneous velocities and the time between them
- (3)

- 1.5 Two blocks of mass  $m$  and  $2m$ , in contact with each other, are placed on a frictionless, horizontal surface.

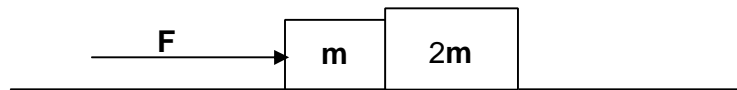

What is the magnitude of the acceleration of the system of masses when a horizontal, non-zero resultant force  $F$  is applied to it to the right, as shown?

- A  $\frac{F}{3m}$
  - B  $\frac{F}{2m}$
  - C  $\frac{2F}{3m}$
  - D  $\frac{F}{m}$
- (3)
- 1.6 The mass and radius of the moon are less than the mass and radius of the earth. If an object is taken from the earth to the moon, the acceleration due to gravity it experiences on the surface of the moon is less than that which it experiences on the surface of the earth. Which ONE of the following statements explains this phenomenon?
- A The object is far from the earth.
  - B There is no atmosphere on the moon.
  - C The radius of the moon is less than that of the earth.
  - D The mass of the moon is less than that of the earth.
- (3)



- 1.7 A body is dropped from a certain height above the ground. Disregard ALL frictional forces. Which ONE of the following physical quantities increases as the body falls freely?
- A Acceleration
  - B Kinetic energy
  - C Resultant force
  - D Gravitational potential energy (3)
- 1.8 A rubber ball is thrown perpendicularly towards a wall and rebounds in the opposite direction. Which ONE of the following statements is the best explanation for the **change in motion** of the ball?
- A The wall has inertia.
  - B The wall exerts a force on the ball.
  - C The energy of the ball is conserved.
  - D The momentum of the ball is conserved. (3)
- 1.9 Two identical balls, M and N, moving on a frictionless, horizontal surface, collide head-on with each other. Ball M has an initial speed of  $v$  and ball N an initial speed of  $4v$ , as shown.

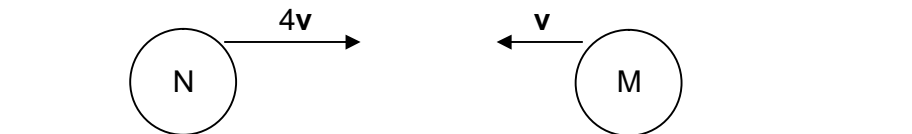

Immediately after the collision ball N continues to the right with a speed of  $v$ . M moves off in the opposite direction to that in which it was moving. Which ONE of the following represents the speed of M **after** the collision?

- A  $4v$
- B  $3v$
- C  $2v$
- D  $v$  (3)



- 1.10 A block of wood is pulled along a frictionless, horizontal surface with a horizontal force  $F$  over a distance  $s$ . The work done by the force is  $W$ .



What force is needed to pull the block along the same surface, while the same amount of work,  $W$ , is done over half the distance ( $\frac{1}{2}s$ )?

- A  $4F$
- B  $2F$
- C  $F$
- D  $\frac{1}{2}F$  (3)
- 1.11 Two identical metallic spheres, M and N, on insulated stands, carry charges of  $+8\text{ nC}$  and  $+2\text{ nC}$  respectively.

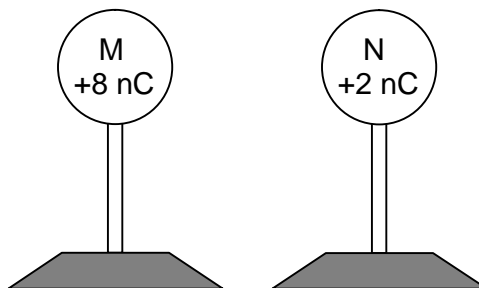

The two spheres are brought into contact with each other and are then separated again. Which ONE of the following combinations is the correct description of the type of charge transferred and the direction of transfer between the two spheres?

	Type of charge transferred	Direction of transfer
A	electrons	from N to M
B	protons	from N to M
C	electrons	from M to N
D	protons	from M to N

(3)



- 1.12 Two metal spheres, P and Q, are mounted on insulated stands. Sphere P is negatively charged while sphere Q is neutral.

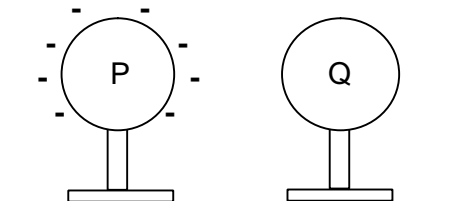

Sphere P is brought closer to sphere Q so that the spheres touch each other. They are then moved back to their original positions.

Which ONE of the following pairs of statements is TRUE about the electrostatic force of sphere P on sphere Q, before touching and after touching?

	Before touching	After touching
A	P has no effect on Q	P repels Q
B	P has no effect on Q	P attracts Q
C	P attracts Q	P repels Q
D	P attracts Q	P attracts Q

(3)

- 1.13 The circuit represented below contains two resistors and three identical ammeters, registering readings  $I_1$ ,  $I_2$  and  $I_3$  on ammeters  $A_1$ ,  $A_2$  and  $A_3$  respectively.

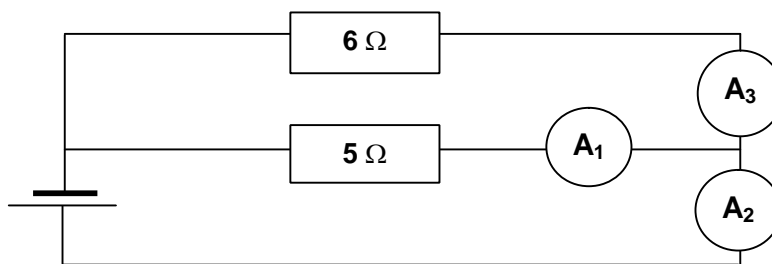

Which ONE of the following statements is FALSE?

- A  $I_2 = I_1 + I_3$ .
- B  $I_1$  is less than  $I_3$ .
- C  $I_2$  is the current in the cell.
- D  $I_3$  is the current in the  $6\ \Omega$  resistor.

(3)



- 1.14 Thabo has two light bulbs, X and Y, marked 100 W and 60 W respectively. He first connects them in parallel (circuit 1) and then in series (circuit 2) in order to compare their brightness in each circuit.

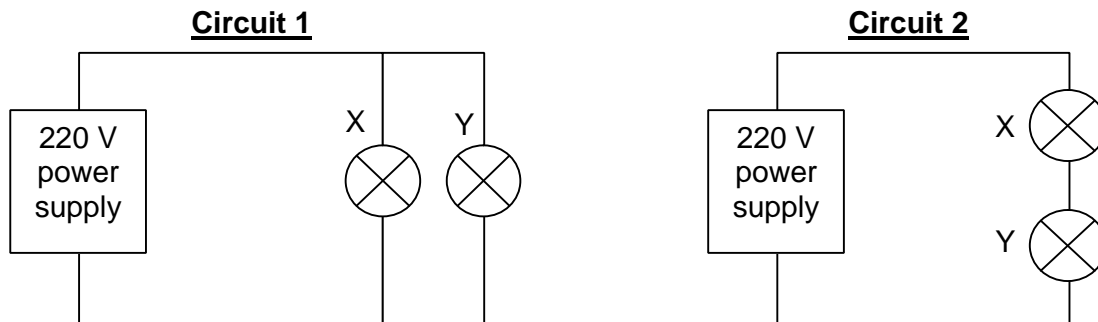

Bulb X glows brighter in circuit 1. In circuit 2 ...

- A X glows brighter because it has a higher power rating.  
 B X glows brighter because it has a higher resistance.  
 C Y glows brighter because it has a higher resistance.  
 D Y glows brighter because it carries more current compared to circuit 1. (3)
- 1.15 In the circuit represented below, switch S is open. The internal resistance of the cell is negligible.

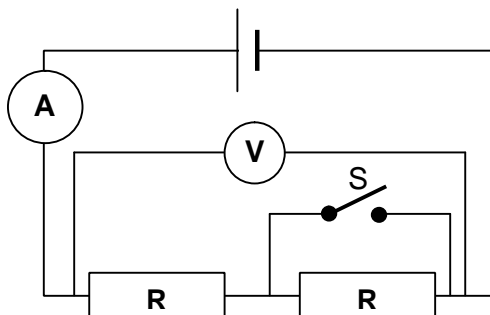

Which ONE of the following combinations correctly represents the change in the readings of the ammeter and the voltmeter when switch S is closed?

	Ammeter reading	Voltmeter reading
A	decreases	increases
B	decreases	remains the same
C	increases	increases
D	increases	remains the same

(3)

[15 x 3 = 45]





**ANSWER QUESTIONS 2 TO 9 IN THE ANSWER BOOK.****INSTRUCTIONS**

1. Start each question on a NEW PAGE in the ANSWER BOOK.
2. Leave a line between subsections, for example 2.1 and 2.2.
3. Show ALL the formulae, as well as the calculations, including substitutions.
4. Number the answers exactly as the questions are numbered.

**QUESTION 2 [START ON A NEW PAGE]**

An object of mass  $m$  rests on a frictionless, horizontal surface. Thabo exerts a horizontal force of magnitude 40 N on the object, while Johan simultaneously exerts a force of magnitude 30 N on the object, at an angle of  $50^\circ$  to the horizontal, as shown. The two forces are in the same vertical plane.

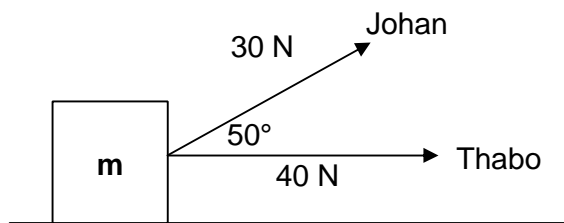

- 2.1 Determine, by accurate construction and measurement (1 cm represents 5 N) the **magnitude** and **direction** of the resultant force that the object experiences. Provide proper force labels on your construction. (No marks will be given for calculations.) (8)
- 2.2 The direction of the force that Johan exerts is then changed so that the angle increases from  $50^\circ$  to  $80^\circ$ . Describe the effect of the change in direction on the following physical quantities, using ONLY the words **increases**, **decreases** or **remains the same**.
  - 2.2.1 The magnitude of the resultant force (2)
  - 2.2.2 The vertical component of the force that Johan exerts (2)
  - 2.2.3 The horizontal component of the force that Thabo exerts (2)

**[14]**

**QUESTION 3 [START ON A NEW PAGE]**

Joyce, mass 60 kg, slides down an inclined ice rink and accelerates from rest. She drops ink on the ice every 2 s, each time leaving a mark (\*). The distances between the marks on the ice are shown below for a section of her motion.

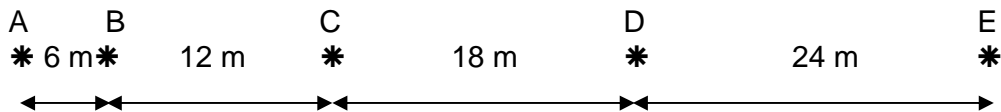

3.1 Calculate the magnitude of her average velocity during the following intervals:

3.1.1 AB (4)

3.1.2 CD (2)

3.2 Hence calculate the magnitude of her acceleration for the interval AD. (4)

3.3 What evidence can you present from the given data to indicate that the acceleration is probably constant during interval AE? (2)

**[12]**

**QUESTION 4 [START ON A NEW PAGE]**

Sipho drops a ball of mass 0,36 kg from the window of his room on the second floor. The ball hits the ground with a speed of  $12 \text{ m}\cdot\text{s}^{-1}$ . Disregard air resistance.

4.1 Calculate the time taken for the ball to reach the ground. (5)

4.2 Calculate the distance the ball falls until it hits the ground. (4)

4.3 Calculate the maximum **increase in the kinetic energy** of the ball during the fall. (5)

4.4 Calculate the magnitude of the momentum of the ball with which it hits the ground. (3)

**[17]**



**QUESTION 5 [START ON A NEW PAGE]**

A box of mass 40 kg is stationary on a straight, horizontal conveyer belt. The conveyer belt is moving to the right at  $3 \text{ m}\cdot\text{s}^{-1}$ . The conveyer belt suddenly jams (stops) and the box slides a distance of 1,2 m on the conveyer belt before coming to rest. Assume that the acceleration is uniform.

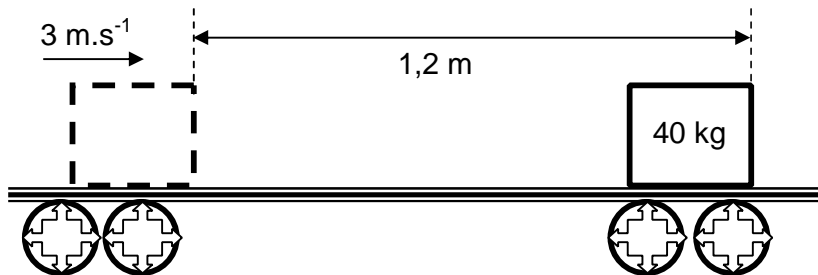

- 5.1 Name, and explain in words, the property of the box that causes it to slide forward on the conveyer belt. (4)
- 5.2 Calculate the **magnitude and direction** of the acceleration of the box while it slides along the belt. (6)
- 5.3 Calculate the magnitude of the average resultant force on the box while it slides. (3)
- [13]**

**QUESTION 6 [START ON A NEW PAGE]**

Sirius is a communication satellite, mass 980 kg, orbiting the earth at a distance of  $4,24 \times 10^7 \text{ m}$  from the centre of the earth. The mass of the earth is  $5,98 \times 10^{24} \text{ kg}$ .

- 6.1 State in words, **Newton's Law of Universal Gravitation**. (4)
- 6.2 Calculate the magnitude of the force that the earth exerts on Sirius. (5)
- 6.3 Suppose the mass of Sirius were doubled. How would the **magnitude** of the force of the earth on Sirius be affected? (2)
- [11]**



**QUESTION 7 [START ON A NEW PAGE]**

Two small metal spheres, A and B carrying charges of  $-4 \times 10^{-12} \text{ C}$  and  $-3 \times 10^{-12} \text{ C}$  respectively, are mounted on insulated stands as shown. The distance between the centres of the spheres is 5 cm.

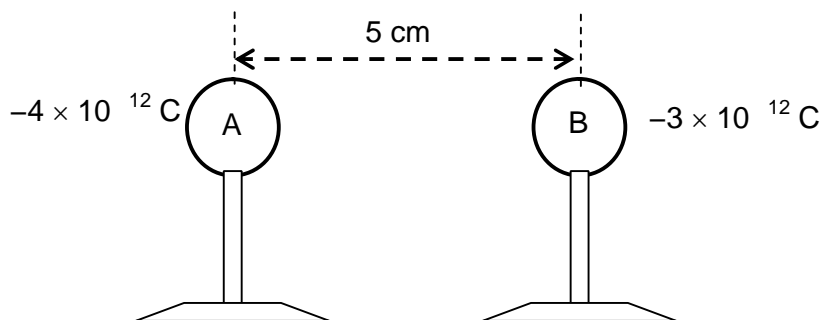

- 7.1 Draw the resultant electric field pattern produced by A and B. (4)
- 7.2 Calculate the **magnitude and direction** of the force that A exerts on B. (6)

*Sphere A is moved and makes contact with sphere B. It is then moved back to its original position.*

- 7.3 Calculate the new charge on each of the spheres. (3)
- 7.4 How does the magnitude of the force that sphere A exerts on sphere B change? Answer by writing **ONLY increases, decreases or remains the same**. (2)
- [15]**



**QUESTION 8 [START ON A NEW PAGE]**

Learners in a school are required to perform an experiment to obtain the relationship between the potential difference across an unknown resistor and the current in the unknown resistor.

Azeez and Ziyanda connect the apparatus correctly and obtain the following results.

<b>Current in ampere</b>	<b>Potential difference in volt</b>
0	0
0,26	1,5
0,60	3,2
0,72	4,2
0,96	5,4

- 8.1 Use a suitable scale to draw and label a system of axes, with potential difference on the vertical (dependent) axis and current on the horizontal (independent) axis, on the graph paper **provided on the back of the answer sheet of QUESTION 1 or as a separate sheet**. Plot the points and draw the straight-line graph. (6)
- 8.2 State the relationship between the potential difference across the unknown resistor and the current in the resistor. (2)
- 8.3 Calculate the gradient of the graph. (4)
- 8.4 This experiment forms the basis of an important law. Name this law. (2)
- [14]**



**QUESTION 9 [START ON A NEW PAGE]**

In the circuit represented below, the battery has an emf of 12 V and a negligible internal resistance. The ammeter has a negligible resistance and a reading of 1,2 A. One of the three resistors has an unknown resistance **R**.

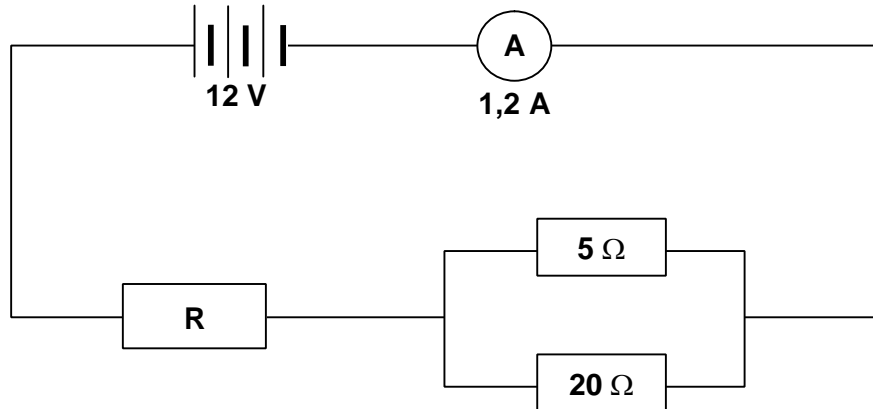

- 9.1 Calculate the effective resistance of the two resistors in parallel. (4)
- 9.2 Calculate the resistance of **R**. (5)
- [9]**

---

**TOTAL QUESTION 1 : 45**  
**TOTAL QUESTIONS 2 – 9 : 105**  
**GRAND TOTAL : 150**

