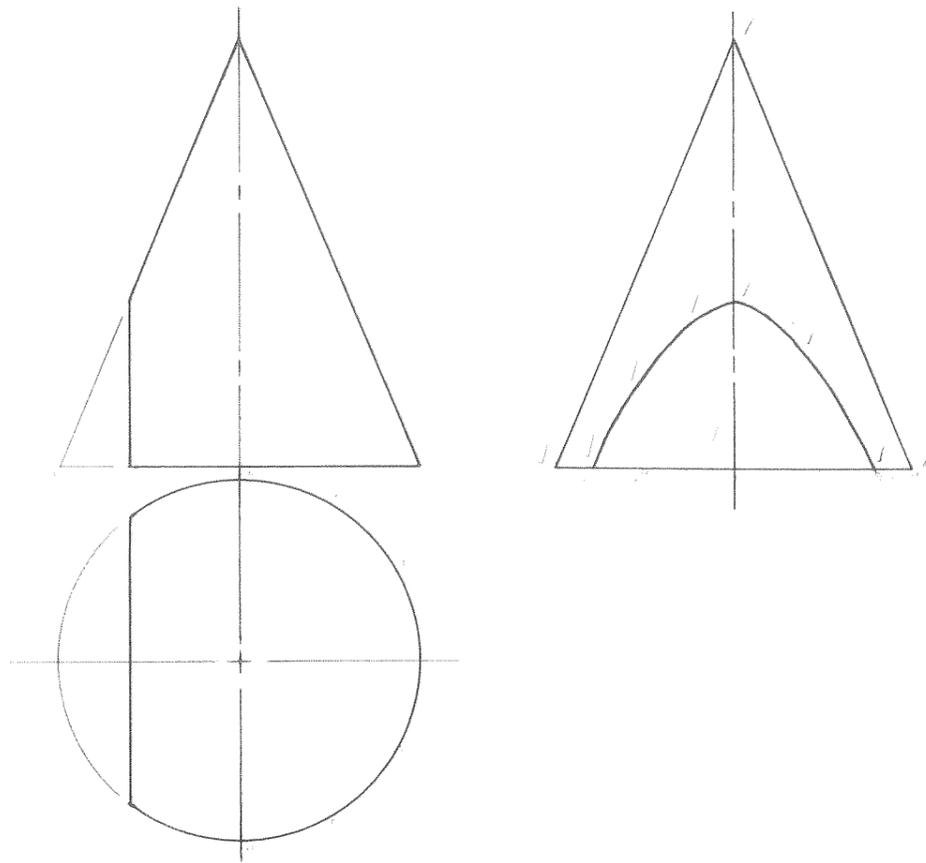

Fig.11.



10/2

(5)

Fig 1.2

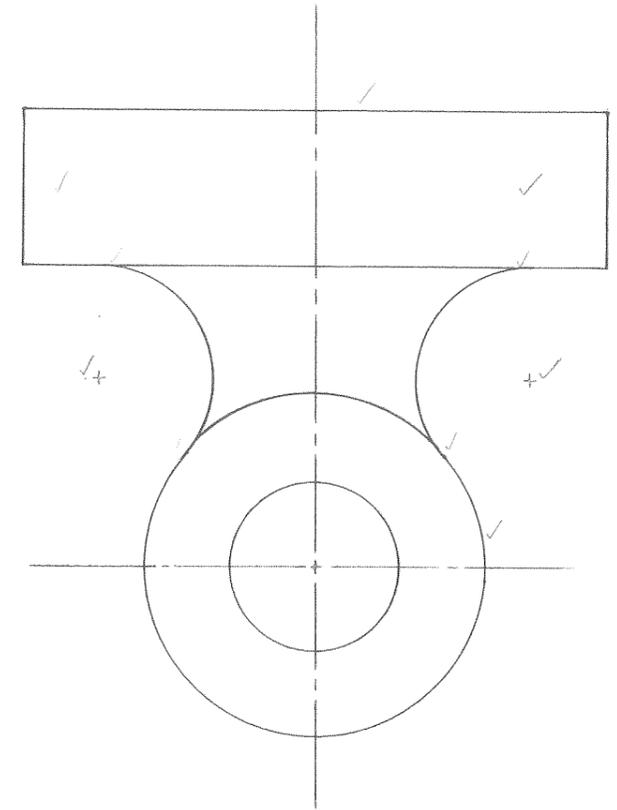
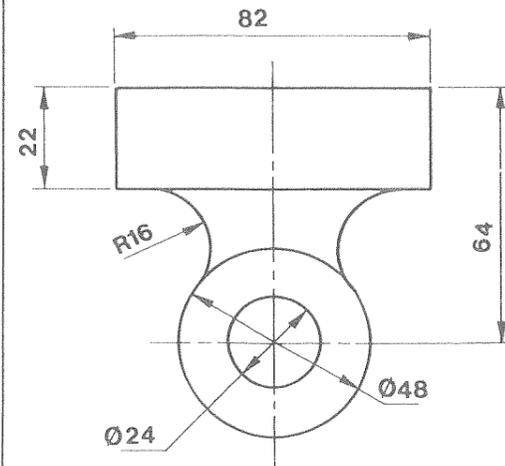

10/2

(5)

Fig.13

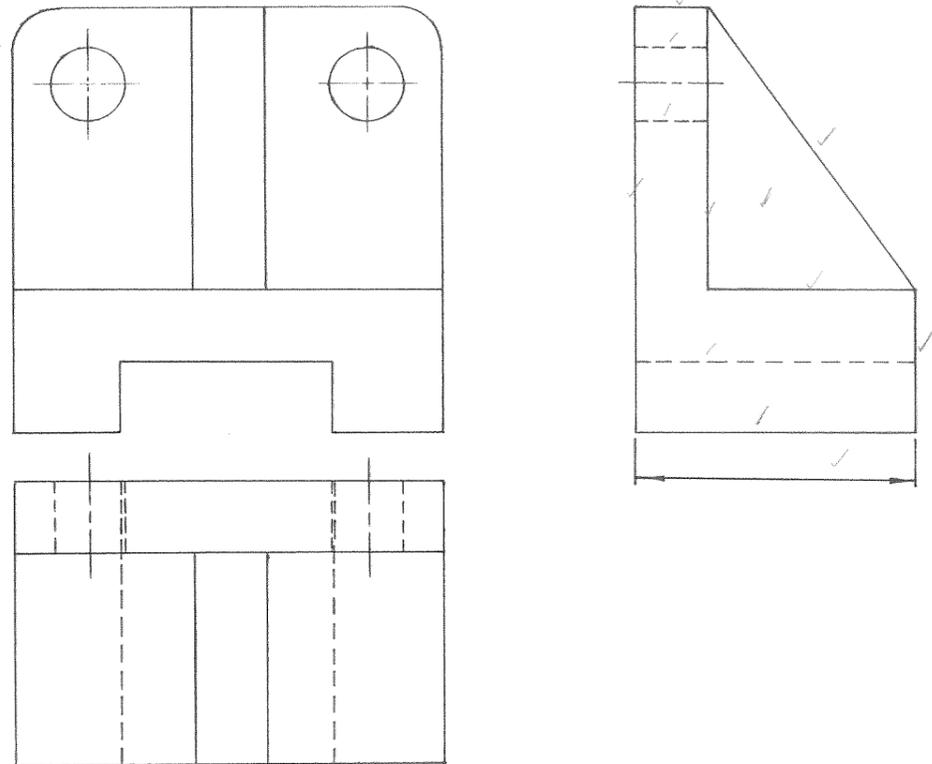

12/2

(6)

Fig.14

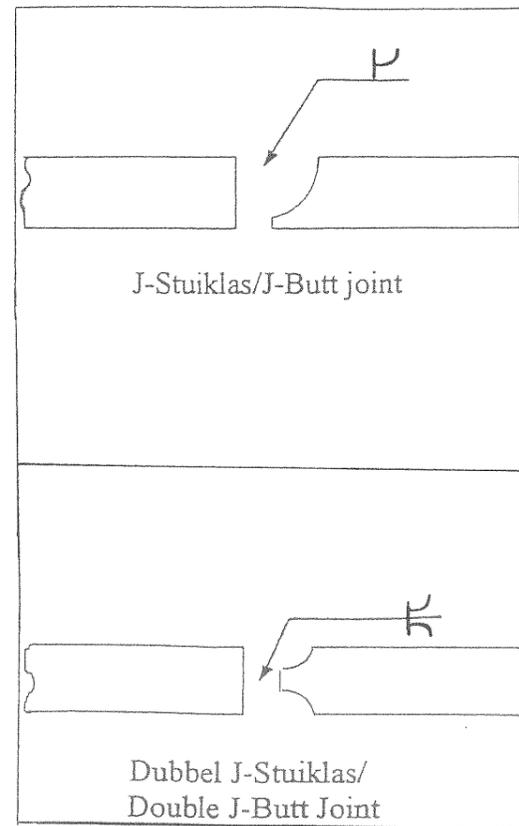

J-Stuiklas/J-Butt joint

Dubbel J-Stuiklas/
Double J-Butt Joint

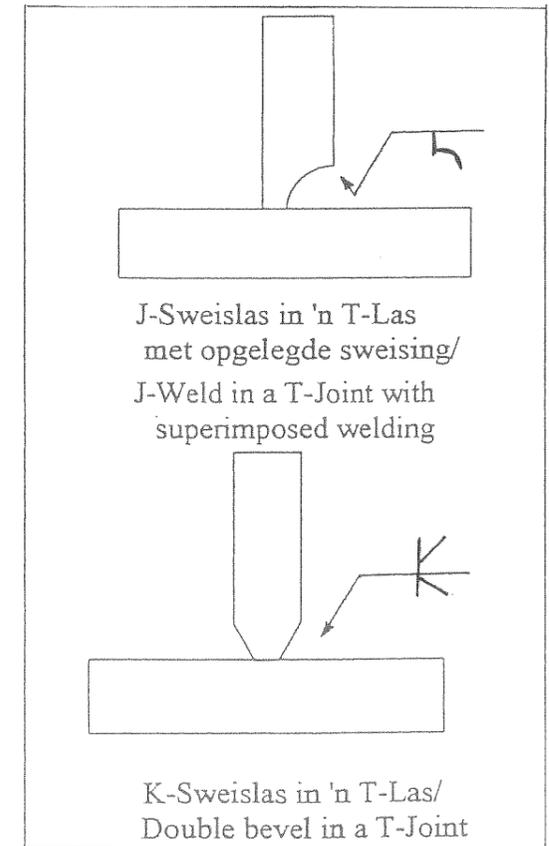

J-Sweislas in 'n T-Las
met opgelegde sweising/
J-Weld in a T-Joint with
superimposed welding

K-Sweislas in 'n T-Las/
Double bevel in a T-Joint

(4)

[20]

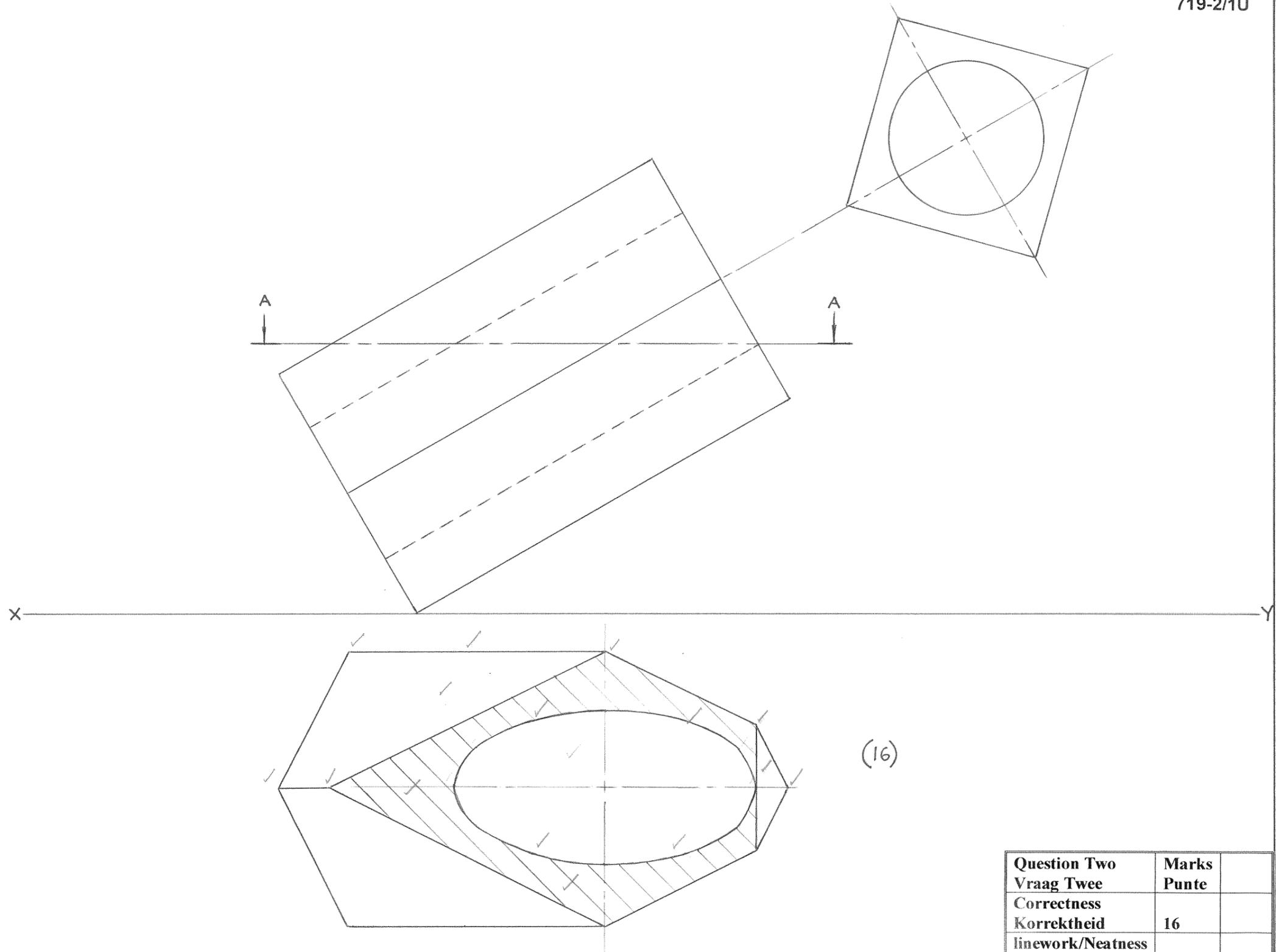

(16)

Question Two Vraag Twee	Marks Punte	
Correctness Korrektheid	16	
linework/Neatness lynwerk/Netheid	2	
Accuracy Akuraatheid	2	
Total/Totaal	20	

Fig. 3

719-2/1U

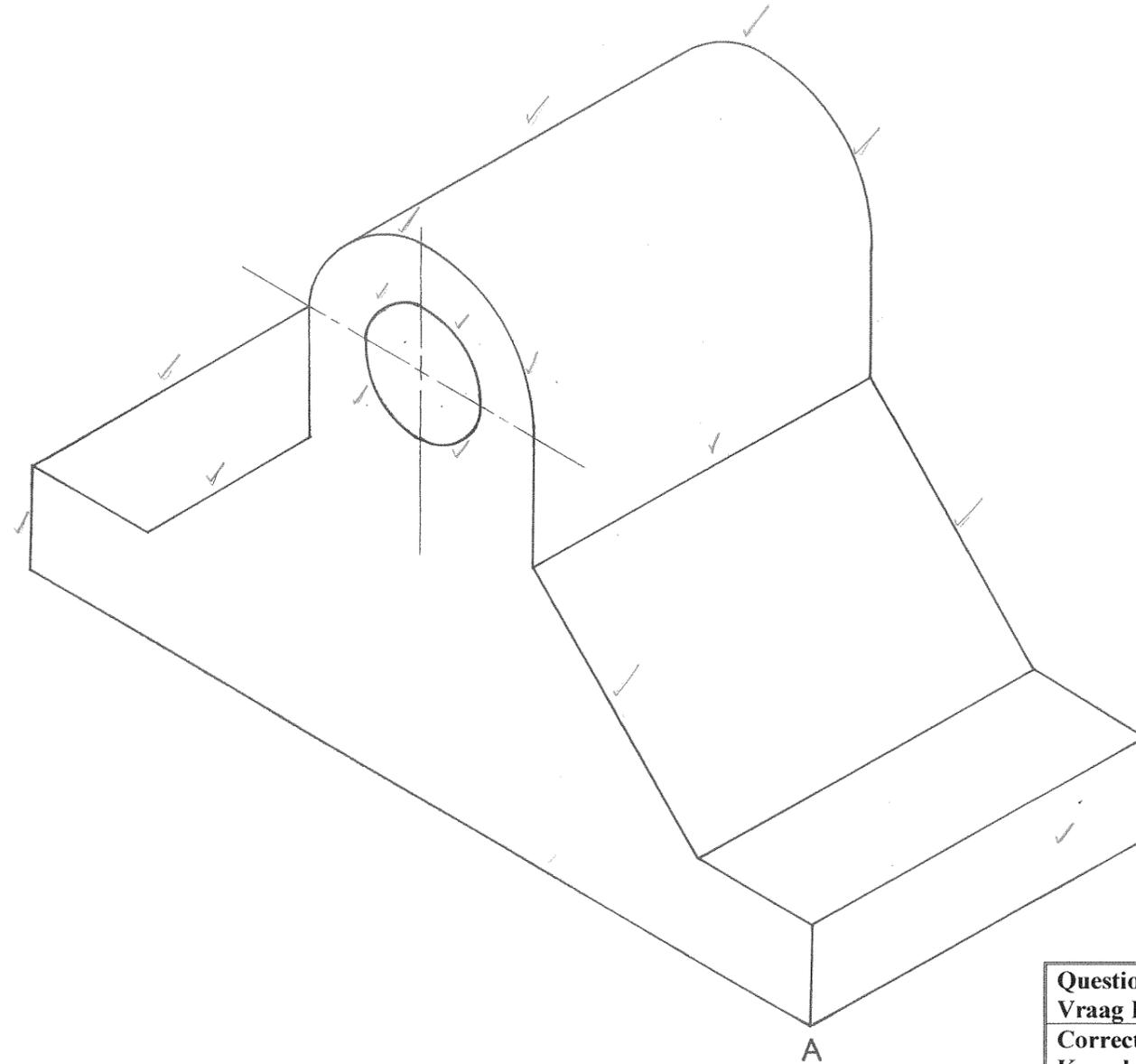
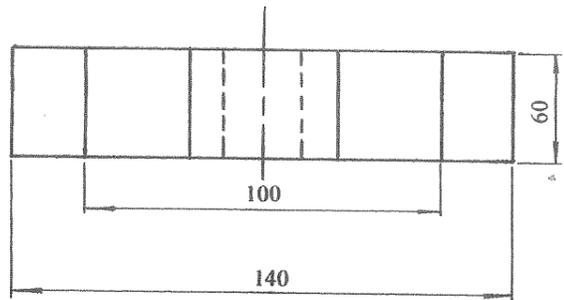
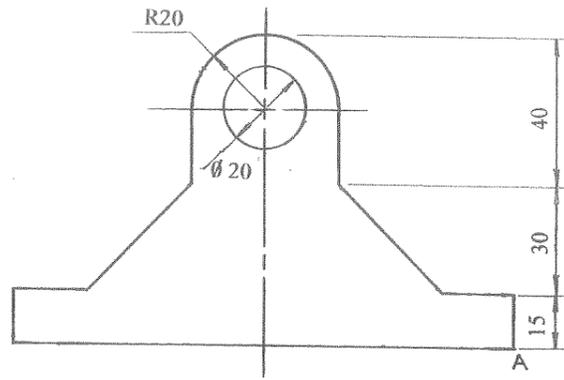

Question Three Vraag Drie	Marks Punte	
Correctness Korrektheid	8	
Insight/Insig	2	
Circles/Sirkels	8	
linework/Neatness lynwerk/Netheid	2	
Total/Totaal	20	

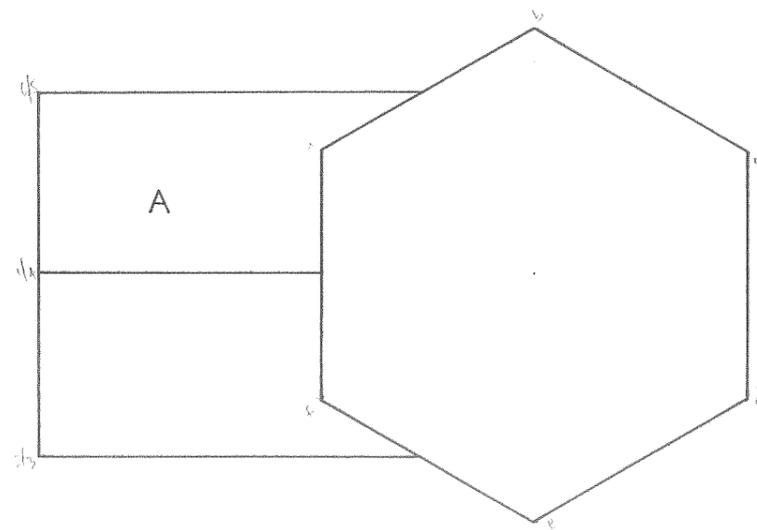
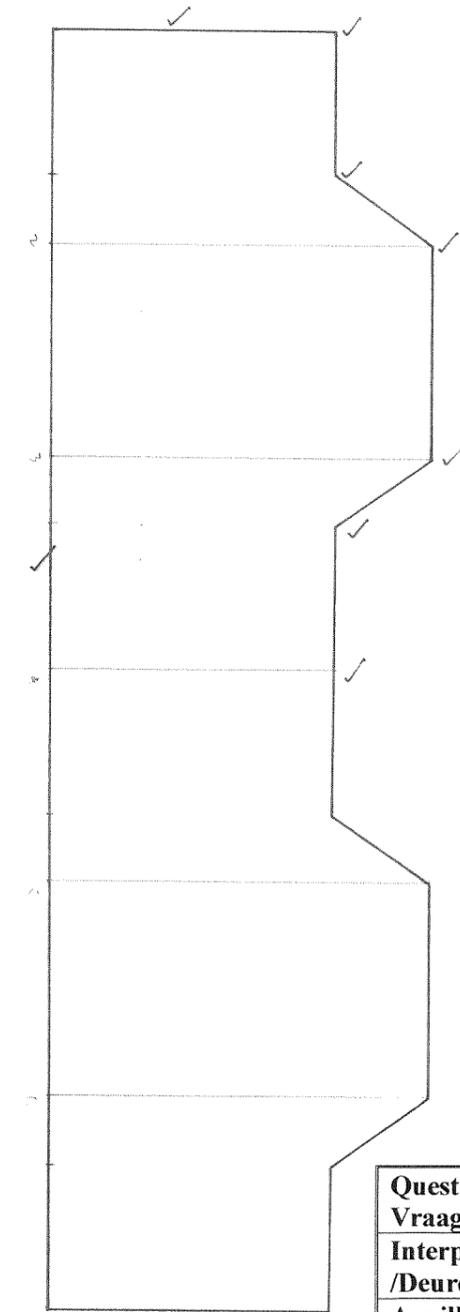
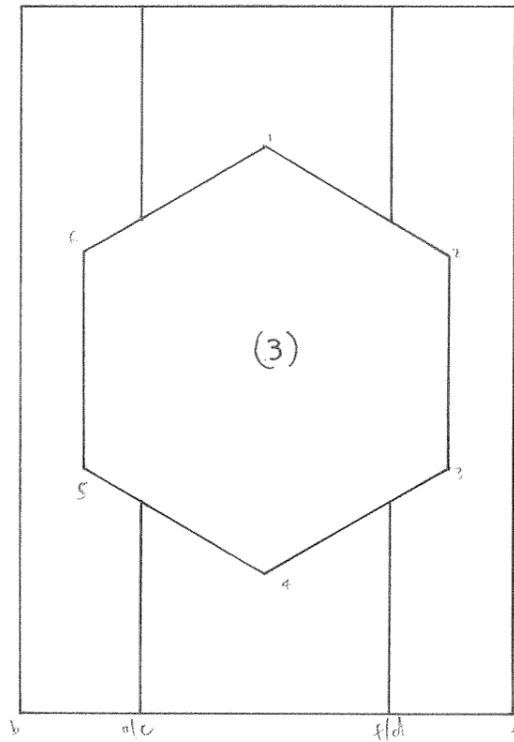
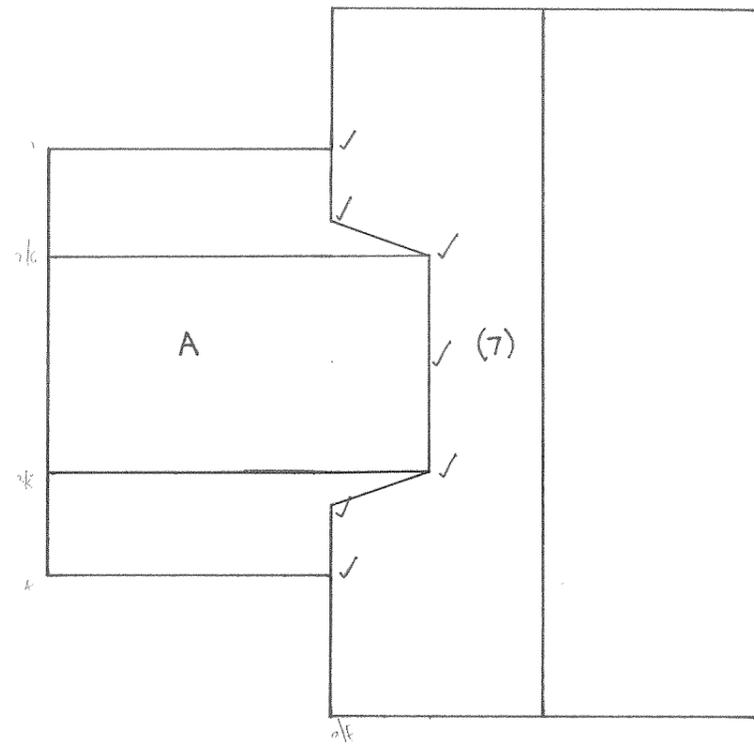

Question Four Vraag Vier	Marks Punte	
Interpenetration curve /Deurdringingskromme	7	
Auxillary View/ Hulpaansig	3	
Development of A Ontwikkeling van A	8	
Linework Lynwerk	2	
Total/Totaal	20	

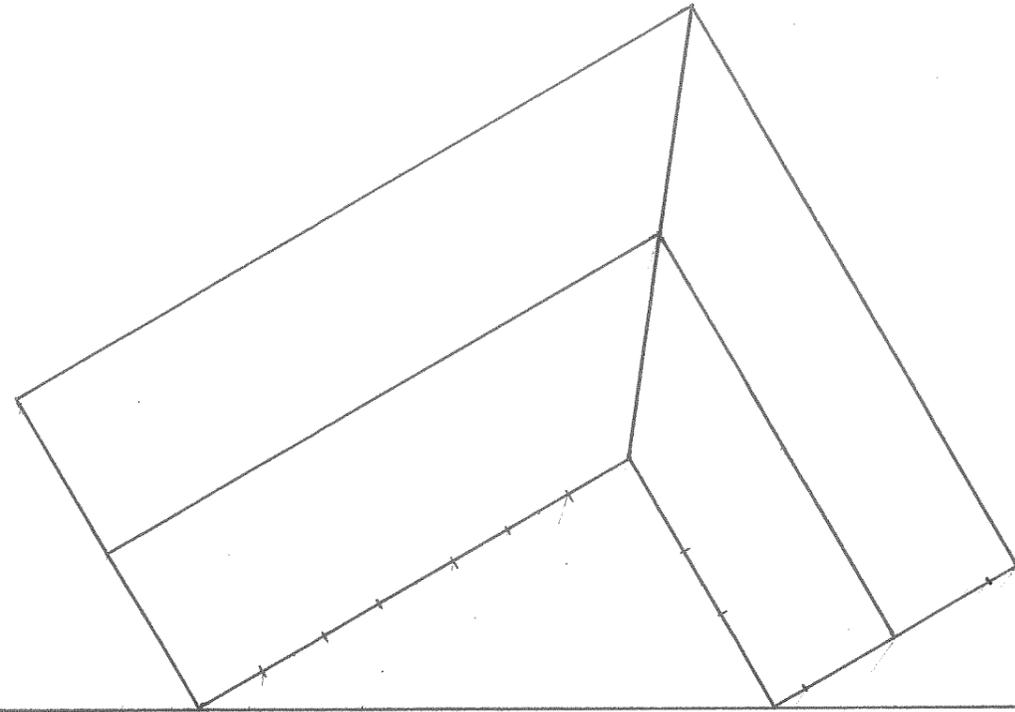

PP

HL

LVP //

RVP //

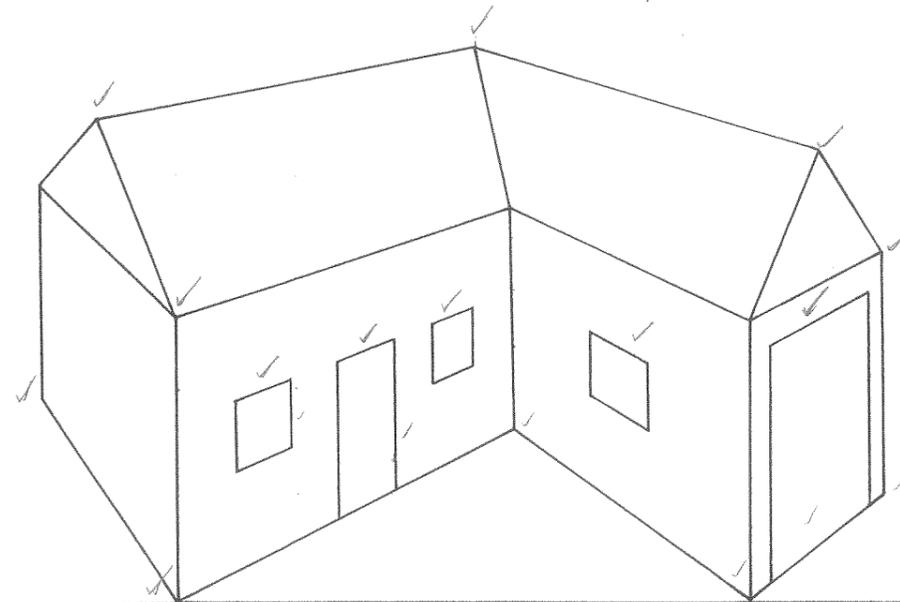

SP

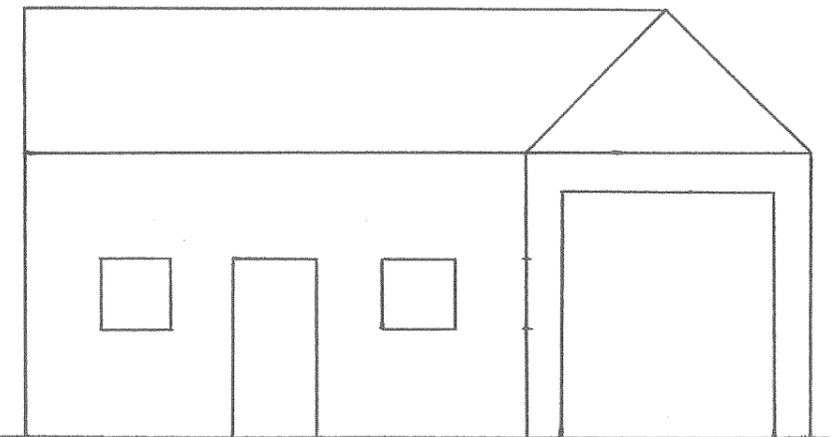

Question Five	Marks	
Vraag Vyf	Punte	
Vanishing Points	4	
Verdwynpunte		
Insight/Insig	2	
Correctness		
Korrektheid	12	
Linework/Lynwerk		
Neatness/Netheid	2	
Total/Totaal	20	