



education

Department:
Education
REPUBLIC OF SOUTH AFRICA

**NATIONAL
SENIOR CERTIFICATE**

GRADE 12

ELECTRICAL TECHNOLOGY

EXEMPLAR 2008

MARKS: 200

TIME: 3 hours

This question paper consists of 12 pages, a formula sheet and a glossary.

INSTRUCTIONS AND INFORMATION

1. Answer ALL the questions.
2. Sketches and diagrams must be large, neat and fully labelled.
3. ALL calculations must be shown and should be rounded off correctly to TWO decimal places.
4. Number the answers correctly according to the numbering system used in this question paper.
5. A formula sheet is attached at the end of the question paper.
6. Non-programmable calculators may be used.

QUESTION 1: TECHNOLOGY, SOCIETY AND THE ENVIRONMENT

- 1.1 Technological advancement has an influence on different cultures. Describe TWO examples where technology has influenced your culture. (4)
- 1.2 Technological skills development is important for economic growth. State TWO competencies that are required of a successful entrepreneur. (4)
- 1.3 With reference to HIV/Aids, name ONE precaution that one has to take when treating a person who has been injured. (2)
- [10]**

QUESTION 2: THE TECHNOLOGICAL PROCESS

Both hands of an old man have been crippled with rheumatism. He can barely pick up a book. His fingers are locked solid, therefore his hands are useless. However, he can use his feet and move his arms.

- 2.1 Develop FIVE specifications for a designed, finished product that should be able to solve the old man's problem as stated above. (5)
- 2.2 Research and investigation enable the designer to analyse existing products in order to understand and solve the problem better. Describe THREE methods of collecting data regarding the design problem. (3)
- 2.3 List TWO appropriate technologies you can use to present and communicate your design effectively. (2)
- [10]**

QUESTION 3: OCCUPATIONAL HEALTH AND SAFETY

- 3.1 Describe ONE unsafe condition that can develop in an electrical technology workshop. (2)
- 3.2 3.2.1 Describe TWO good housekeeping rules that will ensure that the electrical technology workshop is a safe place to work. (4)
- 3.2.2 Describe TWO precautions that must be taken when working with portable electrical equipment. (4)
- [10]**

QUESTION 4: THREE-PHASE AC GENERATION

- 4.1 Briefly explain, with the aid of a neatly labelled sketch with wave forms and a phasor diagram, the generation of three-phase current. (5)
- 4.2 Three loads, each having a resistance of 50Ω , are connected in star formation to a 380 V, three-phase supply.
- Determine the following:
- 4.2.1 Phase voltage (2)
- 4.2.2 Phase current (2)
- 4.2.3 Line current (1)
- [10]**

QUESTION 5: R, L and C CIRCUITS

- 5.1 Name the type of reactance offered to the flow of electric current in the following:
- 5.1.1 Pure inductive circuit (1)
 - 5.1.2 Pure capacitive circuit (1)
- 5.2 An alternating-current circuit consists of a coil and a capacitor in series. The capacitor has a capacitance of 49 microfarad. The coil has an inductance of 0,14 henry and a resistance of 40 ohms. If the supply voltage is 220 V/50 Hz, calculate the following:
- 5.2.1 Impedance of the circuit (6)
 - 5.2.2 Current flow in the circuit (2)
 - 5.2.3 Voltage across the coil (4)
- 5.3 An alternating-current circuit consists of an inductor of 0,15 H, a capacitor of 150 μF and a resistor of 20 Ω , connected in parallel to a supply of 100 V, 50 Hz.
- Calculate the following:
- 5.3.1 Total current flowing through the circuit (8)
 - 5.3.2 Phase angle. Also state the nature of the phase angle: leading or lagging (4)
- 5.4 Draw a neatly labelled phasor diagram of the circuit in QUESTION 5.3 (not to scale). (4)
- [30]**

QUESTION 6: SWITCHING AND CONTROL CIRCUITS

- 6.1 FIGURE 6.1 shows a circuit of a TRIAC lamp dimmer. Describe the basic operation of the circuit.

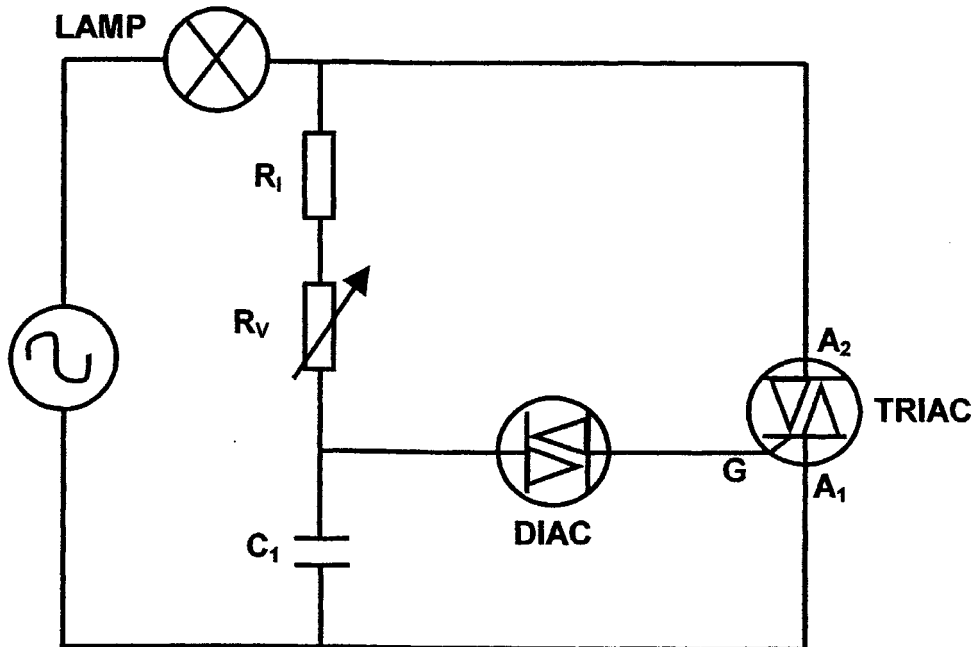

FIGURE 6.1 – TRIAC lamp dimmer circuit

(13)

- 6.2 Explain the functional operation of a DIAC. (6)
- 6.3 Draw the labelled symbol of a thyristor (SCR). (4)
- 6.4 State ONE disadvantage of a thyristor (SCR) compared to a TRIAC. (2)

[25]

QUESTION 7: AMPLIFIERS

7.1 Operational amplifiers often rely on split-power supplies for its operation. Split-power supplies have both a positive and a negative supply. FIGURE 7.1 shows an example of such a split-power supply.

Explain the relevance of using a split-power supply with operational amplifiers. Your answer should include reference to the output of the operational amplifier.

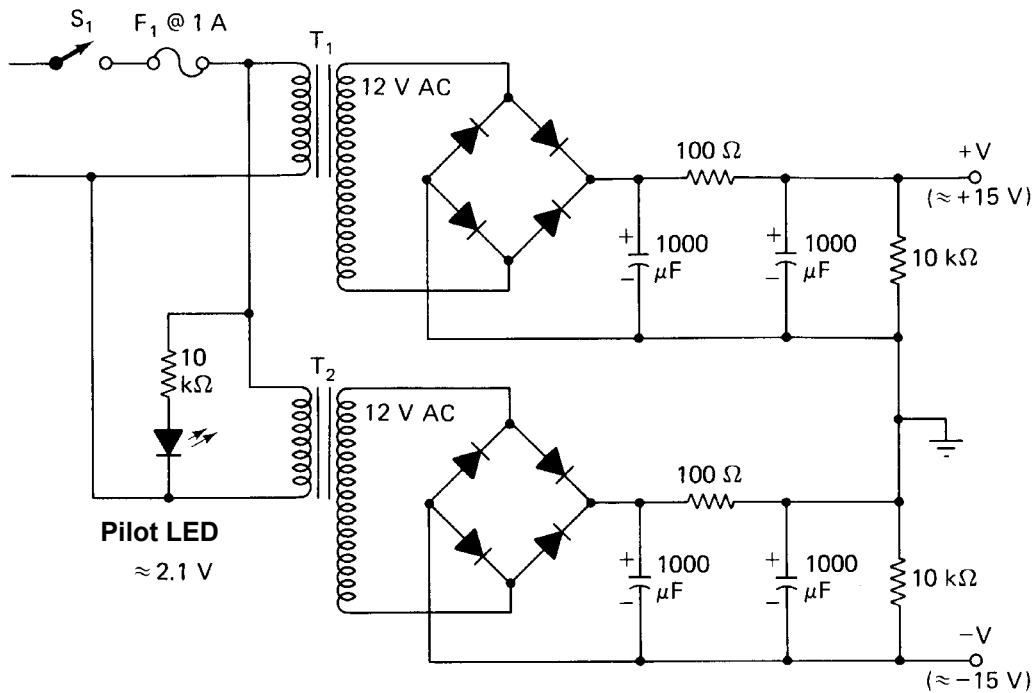

FIGURE 7.1 – The split-power supply used with operational amplifiers (2)

7.2 Operational amplifiers may be configured to have a single input/single output, a differential input/differential output or a differential input/single output.

Explain the term *differential*, with specific reference to operational amplifiers. (2)

7.3 Name THREE characteristics of an ideal operational amplifier. (3)

7.4 Explain the difference between positive and negative feedback, with reference to amplifiers, giving an example of each. (4)

7.5 The operational amplifier in FIGURE 7.2 has been coupled in a certain way. Make use of your knowledge of operational amplifiers to determine the following:

- 7.5.1 In which mode is the operational amplifier coupled? (1)
- 7.5.2 Would this be a good or bad amplifier to use for audio applications, when referring to the input and output wave forms? Motivate your answer accordingly. (2)
- 7.5.3 Determine the gain at which the amplifier is set, making use of the information provided in the circuit in FIGURE 7.2. (2)
- 7.5.4 Explain what you would do to increase the gain of this amplifier. Also explain the nature of the adjustment you would make. (3)

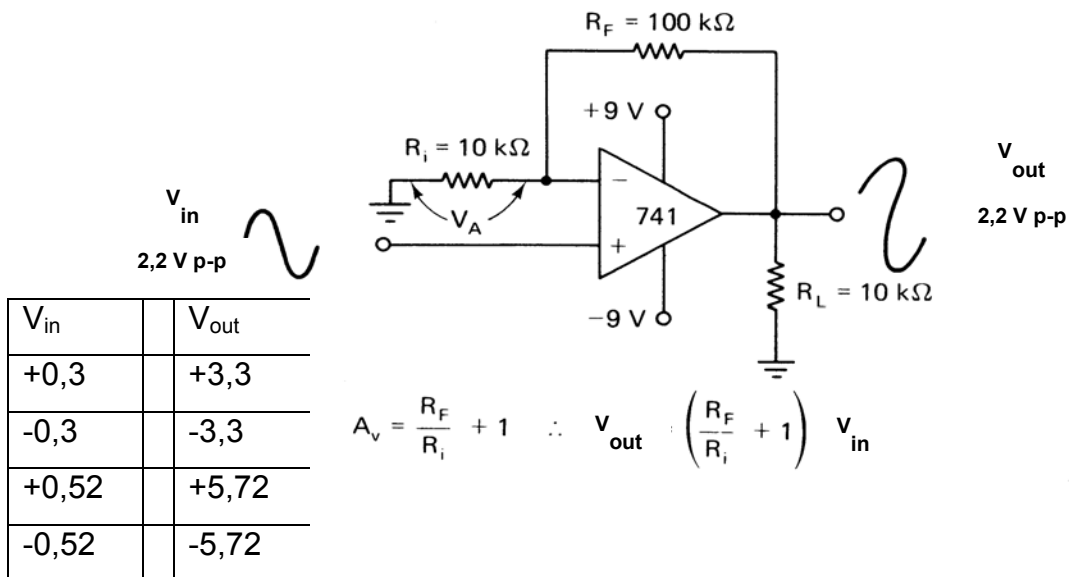

FIGURE 7.2 – Operational amplifier circuit

7.6 Negative feedback holds certain advantages when applied in amplifier circuits. State THREE useful advantages of negative feedback in amplifiers. (3)

7.7 Calculate the resonant frequency of the Wien bridge oscillator shown in FIGURE 7.3.

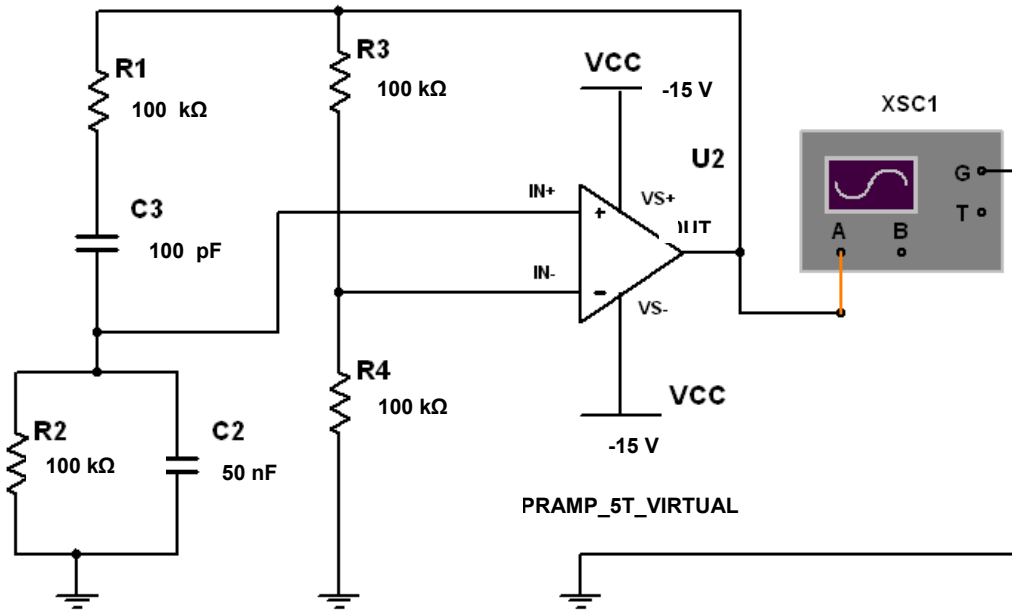

FIGURE 7.3 – Wien bridge oscillator

(3)
[25]

QUESTION 8: THREE-PHASE TRANSFORMERS

8.1 With a three-phase system, three single-phase transformers may be used to step the voltage up or down.

With the aid of a diagram, show how three single-phase transformers may be connected to act as a star-delta unit.

(4)

8.2 Name TWO methods that may be used to reduce the magnetic leakage flux of a transformer.

(2)

8.3 A 30 kVA transformer with a winding ratio of 50:1 is connected in delta-star formation to supply a farm with a line voltage of 380 V.

Calculate the following:

8.3.1 Secondary phase voltage

(2)

8.3.2 Primary line voltage

(3)

8.3.3 Power delivered at full-load at a power factor of 0,85 lagging

(4)

[15]

QUESTION 9: LOGIC CONCEPTS AND PLCs

- 9.1 What is implied by the expression *programmable logic controller* (PLC) or *programmable integrated circuit* (PIC) within the digital environment? (2)
- 9.2 Describe the main difference between a *hard-wired system* and a PLC or *soft-wired system*. (4)
- 9.3 A PLC scans the programme when it executes the commands in the RUN mode. This is done in three main steps, whereafter the process is repeated.
- 9.3.1 Briefly explain the meaning of the statement above, with relation to the operation of programmable logic controllers. (5)
- 9.3.2 Name and describe the THREE main steps that a PLC takes in order to perform its function. (3)
- 9.4 FIGURE 9.1 shows a simple AND gate simulation using two switches to activate a coil. Translate this Boolean equation of $A.B = X$ into a logic ladder diagram for use in a PLC.

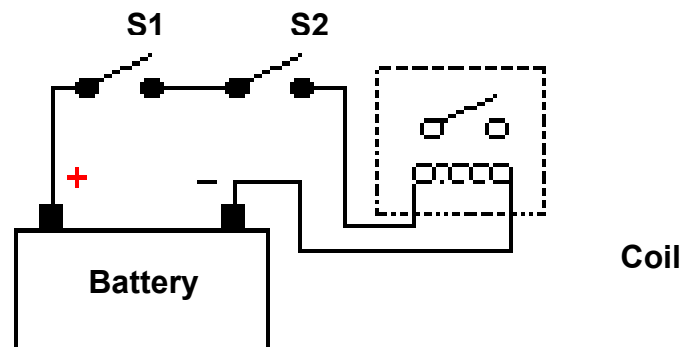
**FIGURE 9.1 – AND gate using switches**

(4)

9.5 FIGURE 9.2 shows a PLC connected to an oil tank.

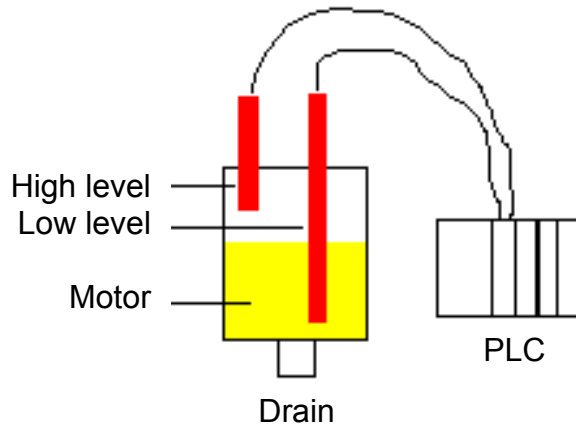

Dispensing oil from a tank

FIGURE 9.2 – Applying a PLC in practice

Problem Statement

- You are controlling lubricating oil being dispensed from a tank in a factory. The tank is draining continuously.
- It is necessary for the motor to pump lubricating oil into the tank until the high-level sensor turns on.
- At that point the motor should be switched off until the level falls below the low-level sensor. Thereafter the motor should be turned on and the process repeated.

Information

- Control is made possible using two sensors. One is put near the bottom and one near the top.
- There is a need for three I/Os (in other words inputs/outputs). Two are inputs (the sensors) and one is an output (the motor).
- Both of the inputs will be NC (normally closed) fibre optic level sensors. When they are NOT immersed in liquid, they will be ON. When they are immersed in liquid, they will be OFF.
- Each input and output device will have an address. This lets the PLC know where the devices are physically connected. The addresses are shown below.

Inputs	Address	Output	Address	Internal Utility Relay
Low-level sensor	0000	Motor	0500	1000
High-level sensor	0001			

9.5.1 Determine whether the following Boolean expression will satisfy the above problem statement:
 $A.B + \bar{A}\bar{B} = X$ (2)

9.5.2 Make use of the information provided in the problem statement and derive the logic ladder diagram that will programme the PLC to perform the function satisfactorily. (7)

9.5.3 Each of the inputs and outputs have been assigned an address. Explain why this is done with reference to PLC devices. (2)

9.6 Determine the simplified Boolean expression for the logic circuit of FIGURE 9.3 below and draw the equivalent logic circuit for your answer.

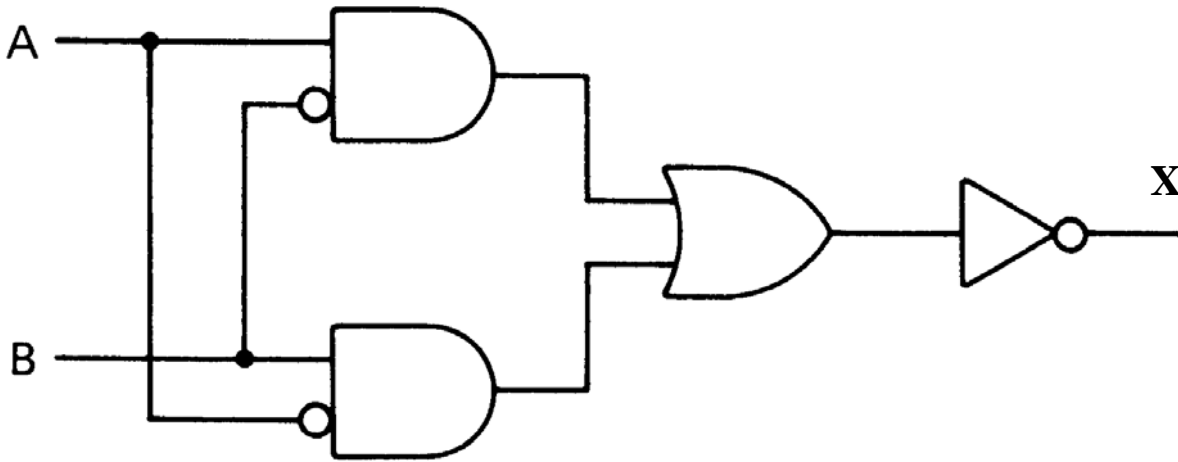

FIGURE 9.3 – Logic circuit

(6)
[35]

QUESTION 10: THREE-PHASE MOTORS AND CONTROL

10.1 A three-phase motor operating off a 380 V system develops 8 kW. The motor has a power factor of 0,8 and an efficiency rating of 100%. If the motor is started by a star-delta starter, calculate the following at full load:

- 10.1.1 Line current and phase current (5)
- 10.1.2 Input in kVA (4)

10.2 Why is a star-delta starter used to start three-phase motors? (3)

10.3 Explain the term *no-volt protection* with reference to motor starters. (4)

10.4 Explain the term *normally closed* with reference to motor starters. (4)

10.5 How can the rotation direction of a three-phase motor be reversed? (1)

10.6 Describe the basic principle of operation of a squirrel-cage motor. (8)

10.7 Why must the casing of a three-phase motor be earthed? (1)
[30]

TOTAL: 200

FORMULA SHEET/FORMULEBLAD

$$X_L = 2\pi FL$$

$$X_C = \frac{1}{2\pi FC}$$

$$Z = \sqrt{R^2 + (X_L - X_C)^2}$$

$$I_T = \sqrt{I_R^2 + (I_C - I_L)^2}$$

$$V_T = \sqrt{I_R^2 + (V_C - V_L)^2}$$

$$F_r = \frac{1}{2\pi\sqrt{LC}}$$

$$Q = \frac{1}{R} \sqrt{\frac{L}{C}} \quad \text{Parallel}$$

$$Q = \frac{X_L}{R} = \frac{V_L}{V_R} \quad \text{Series}$$

$$\cos\theta = \frac{I_R}{I_T}$$

$$\cos\theta = \frac{R}{Z}$$

$$\left. \begin{array}{l} P = VI \cos\theta \\ S = VI \\ Q = VI \sin\theta \end{array} \right\} \text{Single phase}$$

$$\left. \begin{array}{l} P = \sqrt{3} V_L I_L \cos\theta \\ S = \sqrt{3} V_L I_L \\ Q = \sqrt{3} V_L I_L \sin\theta \end{array} \right\} \text{Three phase}$$

$$\left. \begin{array}{l} V_L = V_{Ph} \\ I_L = \sqrt{3} I_{Ph} \end{array} \right\} \text{Delta}$$

$$\left. \begin{array}{l} V_L = \sqrt{3} V_{Ph} \\ I_L = I_{Ph} \end{array} \right\} \text{Star}$$

$$f = \frac{1}{T}$$

$$A_v = \frac{R}{R_{in}} + 1$$

$$\frac{V_1}{V_2} = \frac{N_1}{N_2} = \frac{I_2}{I_1}$$

$$\eta = \frac{P_O}{P_I}$$

$$\beta = \frac{I_C}{I_B}$$

$$I_b = I_e - I_c$$

$$P_G = 10 \log \frac{P_o}{P_i}$$

GLOSSARY OF TERMS

(related to this question paper only)

ABBREVIATION/ TERM	DESCRIPTION	SYMBOL
SCR	Silicon-controlled rectifier (thyristor) – SCR	
Henry	Unit for inductance in a coil/inductor	H
Ampere	Unit of current	I
Ohm	Unit of resistance	Ω
Volt	Unit of voltage	V
k	Kilo. Unit = 1×10^3	k
m	Milli. Unit = 1×10^{-3}	m
μ	Micro. Unit = 1×10^{-6}	μ
n	Nano. Unit = 1×10^{-9}	n
p	Pico. Unit = 1×10^{-12}	p
PIC	Programmable integrated circuit	
PLC	Programmable logic control	