

Question Paper

Test Date-18 August,2013

Deputy Engineer (Electrical) / Assistant Electrical Inspector Group A – Public Works Department

Section-1(General Aptitude- Q 'n no-1-25)

Q No.-1	For which special reason was the Right to Information bill needed in 2005?
1	Increasing awareness about policy.
2	Making it easier for government officials.
3	Making government more responsible.
4	Increasing citizen participation.

Q No.-2	Who cannot make an RTI application?
1	Corporations
2	Individual citizen
3	Workers in a factory
4	Government employees

Q No.-3	What information can be withheld under RTI?
1	The data collected about defence personnel
2	Public works which are yet to be completed
3	Treaties made with other countries on border security.
4	That which could lead to breach of national security.

Q No.-4	Which of these organisations would not come under the RTI?
1	Non government organisation funded by State
2	Central Bureau of Investigation.
3	Semi Autonomous organisation
4	Public works departments

Q No.-5	Who appoints the officers of the Central Information Commission?
1	Chief Justice of India
2	President of India
3	Cabinet Secretary
4	UPSC.

Q No.-6	What is the main focus of the right to Education Act,2009.
1	To bring all the private and aided Schools under governmental control
2	To offer free and compulsory Education to children between six to Fourteen years.
3	To make-up the shortage of trained teachers through the services of parents.
4	To make Secondary Education accessible to all children in the whole country.

Q No.-7	Which of these approaches would help to solve the twin problem of earthquake and flood in the Himalaya?
1	Increase forest cover in the upper reaches .
2	Design modern sturdy buildings
3	Live with Nature, not meddle with it
4	Control the rivers with dams and barrages

Q No.-8	What did the recent law regarding mining rights declare?
1	Minerals belong to the State not the land.
2	All minerals found in a place are owned by the owner of the land
3	All minerals are the property of the State along with the land
4	All the land and the minerals belong to the Panchayat.

Q No.-9	Which city has applied to the UNESCO to be considered a Heritage city?
1	Mumbai
2	Kolkata
3	Agra
4	Delhi

Q No.-10	Which mineral has the Indian Rare Earths Ltd been permitted to export ?
1	Monazite
2	Uranium
3	Lithium
4	Thorium

Q No.-11	What is BHEEM?
1	Road roller
2	Rocket to be launched in to space
3	New diesel locomotive engine
4	Mars exploratory vehicle launched

Q No.-12	What is the best reason why special status is provided to tribal and indigenous communities?
1	Providing more facilities exclusively for tribes
2	Bringing Tribal people into the mainstream
3	creating more jobs in government sector
4	ensuring equality as per Constitution

Q No.- 13	Which are the sectors where FDI is not allowed in India, both under the Automatic Route as well as under the Government Route
1	Defence Equipment .
2	Electronic goods.
3	Solar Technology.
4	Agricultural Food processing.

Q No.- 14	Which Indian movie has been adjudged the best in the millennium by England?
1	Mother india
2	Sholay
3	Mughal-e-Azam
4	Alam - ara

Q No.- 15	What privileges do the heritage sites enjoy?
1	Status and security
2	Money for upkeep and care
3	Expertise and labour
4	Advertisement

Q No.- 16	Which Nonagenarian in the world is considered a symbol of peace and non-violence today?
1	Dalai lama
2	Pope Francis
3	Aung Sang Su Chi
4	Nelson Mandela

Q No.- 17	What efforts are being made all over the world to preserve the identity of Indigenous tribes?
1	protection in their natural habitat
2	provision of special status for tribes
3	Recording of their habits and customs
4	Special educational facilities.

Q No.- 18	In which city was the first Asian games held?
1	Beijing
2	Singapore
3	Colmbo
4	Delhi

Q No.- 19	which of the following forms of the classical dance was patronized by the Mughal rulers?
1	Kathkali
2	Kathak
3	Bharatnatyam
4	Manipuri

Q No.- 20	Who won the Wimbledon women single championship in 2013 ?
1	Serena williams
2	Anna Sharpova
3	Sabine Lisciki
4	Marion Bartoli

Q No.- 21	What does IBL stand for?
1	International badminton league
2	Indian basketball league
3	Indian badminton league
4	International basketball league

Q No.- 22	What controversial issue has Snowden raised?
1	Creating a policy for internet privacy.
2	Protection of privacy on internet.
3	Increasing the access to internet.
4	Creating awareness about safety.

Q No.- 23	The duration of the current (12 th) five year plan is:
1	2011-16
2	2012-17
3	2013-18
4	2010-15

Q No.- 24	As per 2013-14 railway budget, Indian Railway will introduce a new hyper luxury class which is known as_____.
1	Udaan
2	Anand
3	Apoorva
4	Anubhuti

Q No.- 25	The first woman to climb Mt Everest with artificial limbs?
1	Bachindri Pal
2	Raha Moharrak
3	Tamae Watanabe
4	Arunima Sinha

Section-2(Electrical engineering- Q 'n no-26-100)

Q No.- 26	The First nuclear power plant was installed in India at
1	Kota
2	Kalpakkam
3	Tarapur
4	Narora

Q No.- 27	The estimated value of installed power plant capacity requirements in India now is
1	3.5×10^5 MW
2	2.5×10^5 MW
3	1.5×10^5 MW
4	1×10^5 MW

Q No.- 28	Which one of the following is NOT considered as commercial energy ?
1	Electrical Energy
2	Oil Energy
3	Coal Energy
4	Solar Energy

Q No.- 29	The Bureau of Energy Efficiency (BEE) has been established in order to
1	Provide policy frame work and direction to national energy conservation
2	Promote power generation avenues in India.
3	Train engineers in Power sector for better performance
4	Increase Transmission efficiency by reduction of losses

Q No.- 30	As per the Electricity Act 2003, the term cogeneration means
1	Interconnection of power systems
2	Production of energy by nonconventional methods
3	Working of power generating agencies together
4	A process which simultaneously produces two or more forms of useful energy

Q No.- 31	Which one of the following is a characteristic of an Ideal voltage source ?
1	The voltage is in direct proportion to current
2	It has zero internal resistance
3	It has infinite internal resistance
4	Open circuit voltage is equal to voltage on full load

Q No.- 32	The number of branches in a network having 4 nodes and 3 independent loops will be
1	5
2	6
3	7
4	8

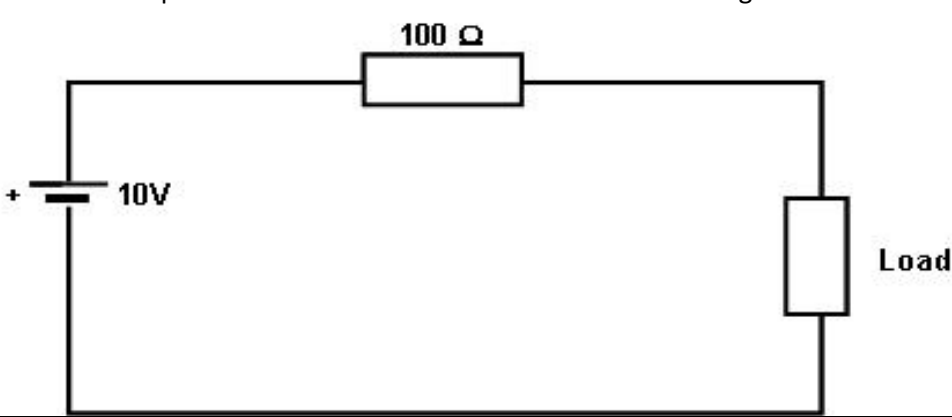
<p>Q No.- 33</p>	<p>The maximum power that can be transferred to the load in the given circuit is</p> 
1	0.25 W
2	0.5 W
3	1.0 W
4	10 W

<p>Q No.- 34</p>	<p>For a 3 phase balanced system, which one of the following conditions are necessary ? A. The line voltages are equal B. The phase difference between line voltages is same C. The impedances in phases are equal</p>
1	A, B, C only
2	A and C only
3	A and B only
4	B and C only

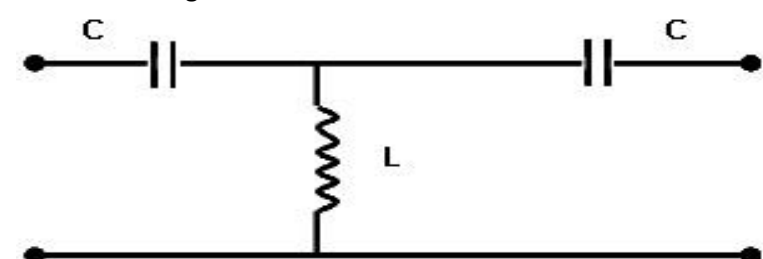
<p>Q No.- 35</p>	<p>The circuit shown in the figure illustrates a</p> 
1	low pass filter
2	high pass filter
3	band pass filter
4	band reject filter

Q No.- 36	The iron losses in a single phase transformer are 5000 watts. The full load copper losses are 6400 watts. At half load, the copper losses and iron losses will be respectively
1	3200 watts and 2500 watts
2	3200 watts and 5000 watts
3	1600 watts and 1250 watts
4	1600 watts and 5000 watts

Q No.- 37	In a transformer zero voltage regulation can be obtained by
1	Resistive loads
2	Inductive loads
3	Capacitive loads
4	Combination of resistive and inductive loads

Q No.- 38	A power transformer will operate at highest efficiency when
1	Iron losses are equal to copper losses
2	Iron losses are less than copper losses
3	Iron losses are more than copper losses
4	Eddy current losses are equal to hysteresis losses.

Q No.- 39	Two transformers are operating in parallel. The load shared will depend on their
1	Efficiency
2	Ratings
3	Turns ratio
4	Per unit impedance

Q No.- 40	Which one of the following combinations of 3 phase transformer can operate in parallel?
1	Star / star and star / delta
2	Delta / star and delta / delta
3	Delta / star and delta / star
4	Delta / delta and delta / delta

Q No.- 41	Which one of the motors should NOT be run on no load ?
1	DC shunt motor
2	DC series motor
3	Induction motor
4	Synchronous motor

Q No.- 42	Wave winding is employed in a DC machine of
1	high current and low voltage rating
2	low current and high voltage rating
3	high current and high voltage rating
4	low current and low voltage rating

Q No.- 43	The most economical method of electrical braking is
1	Plugging
2	Dynamic braking with separate excitation
3	Dynamic braking with self excitation
4	Regenerative braking

Q No.- 44	A single phase motor fails to start and gives humming noise. The reason could be
1	Low voltage
2	High voltage
3	Blown fuses
4	Shorted stator winding

Q No.- 45	If the phase sequences of applied voltage in a 3 phase induction motor is changed, the result will be that
1	No torque will be developed
2	Direction of rotation of the motor will change
3	The slip will increase
4	Motor will draw more current

Q No.- 46	For the same output, the space required by a steam power station is less than
1	diesel power station
2	atomic power station
3	hydropower station
4	gas turbine power station

Q No.- 47	In a thermal power station, the feed water coming to the economizer is heated using
1	low pressure steam
2	high pressure stem
3	furnace heat
4	flue gases

Q No.- 48	A load curve shows the relationship between
1	load and time
2	units generated and time
3	load and current
4	energy output and current

Q No.- 49	The advantages of interconnected power systems is
1	less reserve capacity requirement and higher reliability
2	high reserve capacity requirement and high power factor
3	high reserve capacity and low reliability
4	less faults and high power factor

Q No.- 50	Heavy water is used in nuclear plants as
1	fuel and coolant
2	coolant and moderator
3	shield and moderator
4	fuel and reflector

Q No.- 51	As compared with a solid conductor of the same radius, corona appears on a stranded conductor at low voltage, because the stranding of the conductor
1	helps ionization process
2	makes the current flow spirally
3	produces surfaces of smaller radius
4	reduces the value of current

Q No.- 52	High voltage transmission lines are transposed to
1	reduce corona losses
2	prevent interference with telephone lines
3	prevent short circuit between lines
4	reduce transmission losses

Q No.- 53	In underground cables, the electrostatic stress is
1	maximum at the conductor surface
2	maximum at the sheath
3	minimum at conductor surface
4	same at the conductor and sheath

Q No.- 54	The pu impedance of a line to 50 MVA, 132 KV base is 0.4, the pu impedance to a 100 MVA, 132 KV base will be
1	0.2
2	0.6
3	0.8
4	1.6

Q No.- 55	In HVDC transmission system, the AC harmonics which are eliminated by 12 pulse bridge converters are
1	3 rd harmonics
2	3 rd , 5 th and 7 th harmonics
3	3 rd and 5 th harmonics
4	5 th and 7 th harmonics

Q No.- 56	In case of an unbalanced star connected load supplied from an unbalanced 3 phase 3 wire system, the load currents will consist of
1	positive sequence components only
2	negative sequence components only
3	zero sequence components only
4	positive and negative sequence components only

Q No.- 57	In case of an Air blast circuit breaker, current chopping will be observed, when which one of the following is switched off ?
1	long overhead line
2	bank of capacitors
3	transformer on no load
4	heavy load

Q No.- 58	In distance protection, the relay measures
1	negative sequence impedance of the line from relay upto the fault point
2	positive sequence impedance of the line from relay upto the fault point
3	self impedance of the relay upto the fault point
4	zero sequence impedance of the relay upto the fault point

Q No.- 59	Differential relays protect the equipment against
1	over current
2	internal faults
3	reverse current
4	reverse power

Q No.- 60	Load flow study is used for
1	system planning
2	economic considerations
3	fault calculations
4	stability consideration

Q No.- 61	The sensitivity of a potentiometer can be increased by
1	decreasing the length of potentiometer wire
2	decreasing the resistance of potentiometer wire
3	increasing the length of potentiometer wire
4	increasing the voltage applied

Q No.- 62	A moving iron voltmeter draws a current of 1 mA for full scale value of 100V. If it draws a current of 0.5 mA, the meter reading will be
1	25V
2	50V
3	100V
4	200V

Q No.- 63	Which one of the following digital voltmeters is most suitable to eliminate effect of period noise
1	ramp type
2	integrating type
3	successive approximation type
4	servo type

Q No.- 64	While measuring power in a balanced 3 phase, 3 wire circuit by 2 wattmeter method, the readings of the watt meters are equal and positive. The power factor is
1	Zero
2	0.5
3	0.866
4	Unity

Q No.- 65	According to regulations, the megger voltage for testing 500 V installation should be
1	1000V
2	750V
3	500V
4	250V

Q No.- 66	As per the electricity regulations in India, what should be the permissible percentage voltage drop at the consumers premises ?
1	± 3%
2	± 6%
3	± 10%
4	± 12%

Q No.- 67	Which one of the following neutral systems requires the lightning arrester of least voltage rating ?
1	Insulated
2	solidly earthed
3	resistance earthed
4	reactance earthed

Q No.- 68	Series capacitor is used in a transmission line to
1	reduce line loss
2	limit short circuit current
3	compensate the voltage drop
4	improve load power factor

Q No.- 69	According to regulations, the total connected load and the number of points on a lighting sub circuit should not exceed
1	700 watts and 8 points
2	800 watts and 10 points
3	900 watts and 10 points
4	1000 watts and 10 points

Q No.- 70	Earthing gives protection against
1	Temperature rise
2	Over loading
3	Voltage protection
4	Electric shocks

Q No.- 71	A ring main distribution system is preferred to a radial distribution system because A. Power factor is higher B. Voltage drop in the feeder is less C. Supply is more reliable
1	A and B only
2	A and C only
3	A, B and C only
4	B and C only

Q No.- 72	On which one of the following faults the rating of a circuit breaker is usually determined ?
1	Symmetrical
2	Line to line
3	Single line to ground
4	Double line to ground

Q No.- 73	An isolator is used to break the circuit under
1	No load conditions
2	Fault conditions
3	Abnormal current flow
4	Over voltage conditions

Q No.- 74	Which one of the following sequence of operations is to be followed for operation of circuit breaker, isolator and earthing switch while opening a circuit ?
1	Open circuit breaker → open isolator → close earthing switch
2	Open isolator → open circuit breaker → close earthing switch
3	Open earthing switch → open isolator → open circuit breaker
4	Open circuit breaker → close earthing switch → open isolator

Q No.- 75	A bus coupler circuit breaker is utilized in a substation for joining the
1	transmission line with station bus bar
2	main and transfer bus in a substation
3	generator with transfer bus
4	neutral of the generator with earth

Q No.- 76	If the secondary of a current transformer is open circuited when the primary is carrying current the effect will be that the
1	primary current will become zero
2	high voltage will be induced across secondary causing flash over
3	high voltage will be induced across primary
4	secondary current and voltage will become zero

Q No.- 77	Which one of the bus bar arrangement is more reliable and flexible ?
1	mains and transfer bus scheme
2	one and half breaker scheme
3	double main bus bar scheme
4	single bus bar scheme

Q No.- 78	A bus bar is rated by
1	current and frequency
2	voltage and frequency
3	current, voltage and frequency
4	current, voltage, frequency and short circuit current

Q No.- 79	What is the maximum transmission voltage substation in India
1	400 kV
2	500 kV
3	750 kV
4	1000 kV

Q No.- 80	The electronic cable fault locaters work on the principle of
1	wheat stone bridge
2	reflection of voltage impulse
3	charging and discharging the cable
4	fall of potential

Q No.- 81	One tonne of refrigeration (1 TR) means that the heat removing capacity is
1	21 kJ/min
2	41 kJ/min
3	210 kJ/min
4	410 kJ/min

Q No.- 82	In a vapour compression system, the condition of refrigerant after passing through the compressor and before entering the condenser is
1	wet vapour
2	dry vapour
3	high pressure saturated liquid
4	super heated vapour

Q No.- 83	The Freon group of refrigerant are
1	halo- carbon refrigerants
2	hydro- carbon refrigerants
3	in organic refrigerants
4	high pressure refrigerants

Q No.- 84	During humidification process which one of the following increases ?
1	wet bulb temperature
2	dry bulb temperature
3	relative humidity
4	specific humidity

Q No.- 85	If the speed of a Fan is reduced by 10% the power consumption will
1	decrease by 13%
2	increase by 23%
3	increase by 33%
4	decrease by 23%

Q No.- 86	For fans, the relation between discharge and speed is indicated by the relationship (where Q and N represent the discharge and speed respectively)
1	$Q1/Q2 = N1/N2$
2	$Q1/Q2 = (N1/N2)^2$
3	$Q1/Q2 = (N1/N2)^3$
4	$Q1/Q2 = (N1/N2)^4$

Q No.- 87	Which type of control gives maximum benefits for fan application from energy saving point of view?
1	discharge damper control
2	inlet guide vane control
3	variable pitch control
4	speed control

Q No.- 88	The pressure to be considered for calculating the power required for centrifugal fans is:
1	suction static pressure
2	discharge pressure
3	total static pressure
4	static plus dynamic pressure

Q No.- 89	Motor used for driving blowers and fans is usually
1	slip ring induction motor
2	squirrel cage induction motor
3	dc shunt motor
4	cascade controlled ac motor

Q No.- 90	A heat pump working on a reverse carnot cycle has a co-efficient of performance (COP) of 5. It works as a refrigerator taking 1 kW of work input. The referigerating effect will be
1	2 kW
2	3 kW
3	4 kW
4	5 kW

Q No.- 91	The flicker effect of fluorescent lamps is more visible at
1	lower voltages
2	lower frequencies
3	higher voltages
4	higher frequencies

Q No.- 92	The purpose of choke in a fluorescent tube circuit is to
1	improve power factor
2	reduce radio interference
3	produce high voltage for starting
4	reduce the flicker

Q No.- 93	Which one of the following lamps gives higher luminous efficiency at selected colours for the same wattage ?
1	metal halide lamps
2	compact fluorescent lamps
3	mercury vapour lamps
4	sodium vaour lamps

Q No.- 94	Which one of the following requires the highest level of illumination ?
1	machine shop
2	Printing
3	operation theatre
4	drawing halls

Q No.- 95	The light emitting diodes (LED) have
1	characteristics similar to pnp junctions
2	characteristics similar to npn junctions
3	higher forward and lower reverse breakdown voltage ratings
4	lower forward and higher reverse breakdown voltage ratings

Q No.- 96	The plates of a lead acid battery are most likely to be short circuited if
1	high voltage charging is used
2	too much distilled water is used
3	sediment is collected at the bottom
4	battery is charged very slowly

Q No.- 97	In lead acid batteries, sedimentation occurs due to
1	Battery remaining idle for long periods
2	Over charging of batteries at slow rate
3	Over charging of batteries at high rate
4	Slow charging of batteries at low rate

Q No.- 98	The function of MOSFET in an uninterrupted power supply (USP) is to
1	cut off over load circuit and restart the supply
2	generate and amplify oscillation signals
3	act as switching device at the output section
4	detect abnormal conditions at the input section

Q No.- 99	In a Diesel Generator (DG) set, the white smoke indicates
1	presence of water in the combustion chamber
2	improper combustion
3	burning of oil in combustion chamber
4	worn out piston rings

Q No.- 100	The SAE number of the oil used in DG Sets denotes
1	oil viscosity
2	oil density
3	oil flash point
4	oil ambient temperature