

Edexcel GCSE

Mathematics (Linear) – 1MA0

ANGLES

Materials required for examination

Ruler graduated in centimetres and millimetres, protractor, compasses, pen, HB pencil, eraser.
Tracing paper may be used.

Items included with question papers

Nil



Instructions

Use black ink or ball-point pen.

Fill in the boxes at the top of this page with your name, centre number and candidate number.

Answer all questions.

Answer the questions in the spaces provided – there may be more space than you need.

Calculators may be used.

Information

The marks for each question are shown in brackets – use this as a guide as to how much time to spend on **each** question.

Questions labelled with an **asterisk** (*) are ones where the quality of your written communication will be assessed – you should take particular care on these questions with your spelling, punctuation and grammar, as well as the clarity of expression.

Advice

Read each question carefully before you start to answer it.

Keep an eye on the time.

Try to answer every question.

Check your answers if you have time at the end.

1. The lines in the diagram are straight.

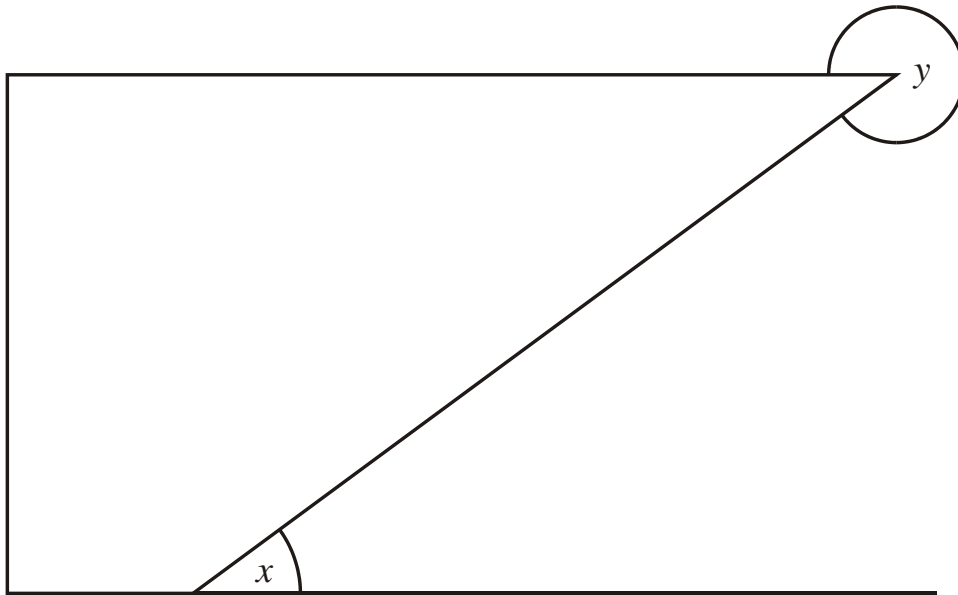

(a) Mark with arrows, (\gg), a pair of parallel lines.

(1)

(b) Mark with the letter R, a right angle.

(1)

(c) What type of angle is shown by the letter

(i) x ,

(ii) y

(2)

(Total 4 marks)

2. The shape is made from a right-angled triangle, a parallelogram and a quadrilateral.

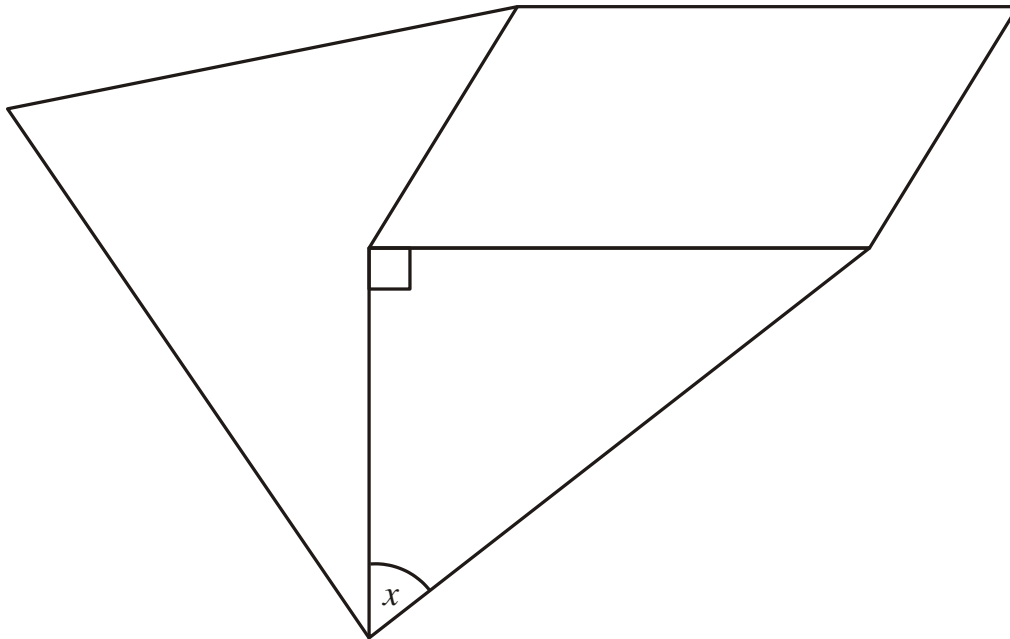

- (a) Mark with arrows (\gg) a pair of parallel lines. (1)
- (b) Mark with the letter *A* an acute angle. (1)
- (c) Mark with the letter *R* a reflex angle. (1)
- (d) Measure the size of angle *x*.

.....^o
(1)
(Total 4 marks)

3.

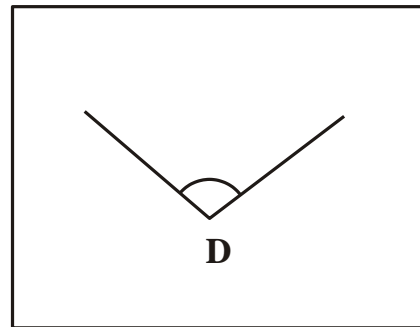
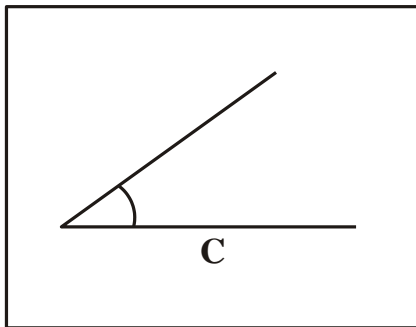
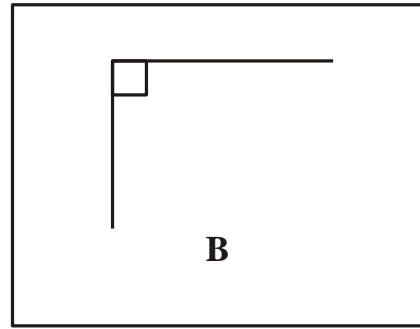
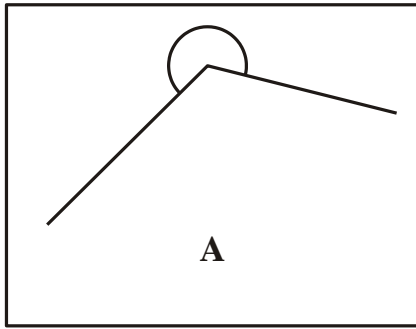

One of the four angles marked in the diagrams above is an obtuse angle.

- (a) Write down the letter of the diagram in which the obtuse angle is marked.

.....

(1)

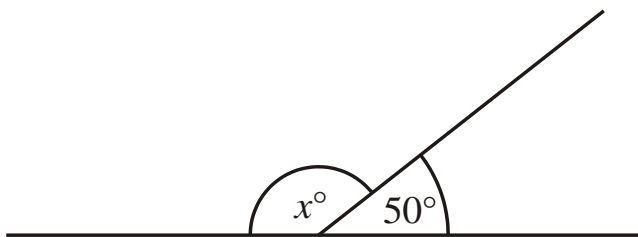

Diagram **NOT** accurately drawn

- (b) Work out the size of the angle marked x° .

.....^o

(2)

(Total 3 marks)

4. (a) Write down the special name for this type of angle.

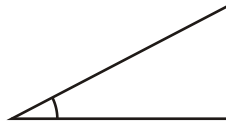

.....

(1)

(b) Write down the special name for this type of angle.

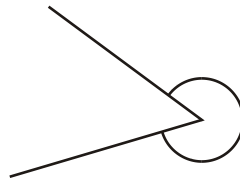

.....

(1)

(c)

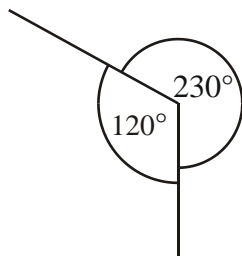

Diagram **NOT**
accurately drawn

This diagram is wrong.
Explain why

.....
.....
.....
.....

(1)

(Total 3 marks)

5. Here is a diagram drawn on a square grid.

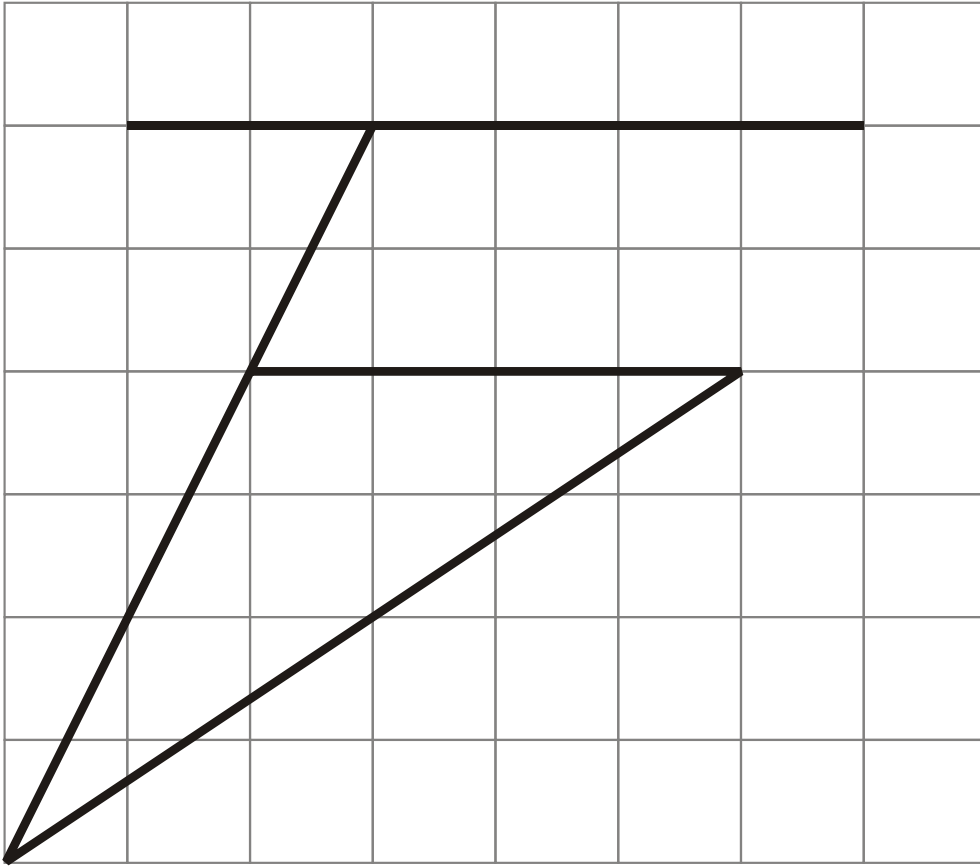

(a) Mark, with arrows (\gg), a pair of parallel lines.

(1)

(b) Mark, with the letter A, an acute angle.

(1)

(c) Mark, with the letter O, an obtuse angle.

(1)

(Total 3 marks)

6. The diagram shows two sides of a rhombus drawn on a grid of centimetre squares.

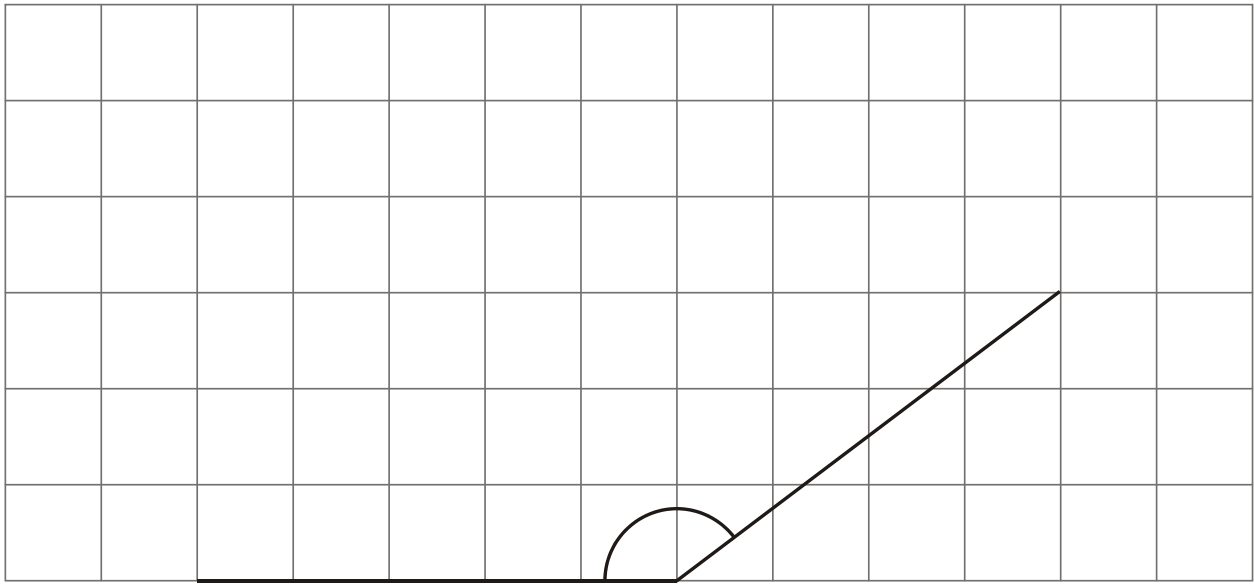

- (a) (i) Measure the size of the angle between these two sides.

.....°

- (ii) What type of angle have you measured?

.....

(2)

- (b) Complete accurately the drawing of the rhombus.

(1)

(Total 3 marks)

7. The diagram shows an angle.

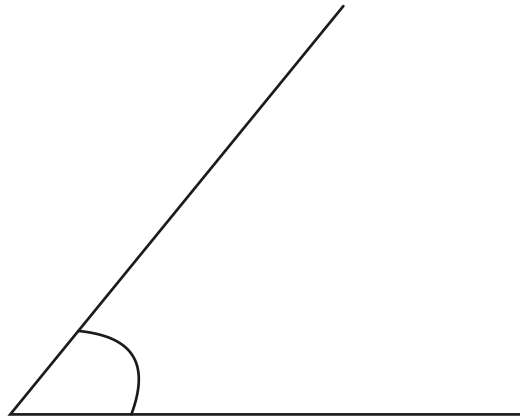

(a) Write down the special name for this type of angle.

..... (1)

(b) Measure the size of the angle.

.....° (1)

(Total 2 marks)

8.

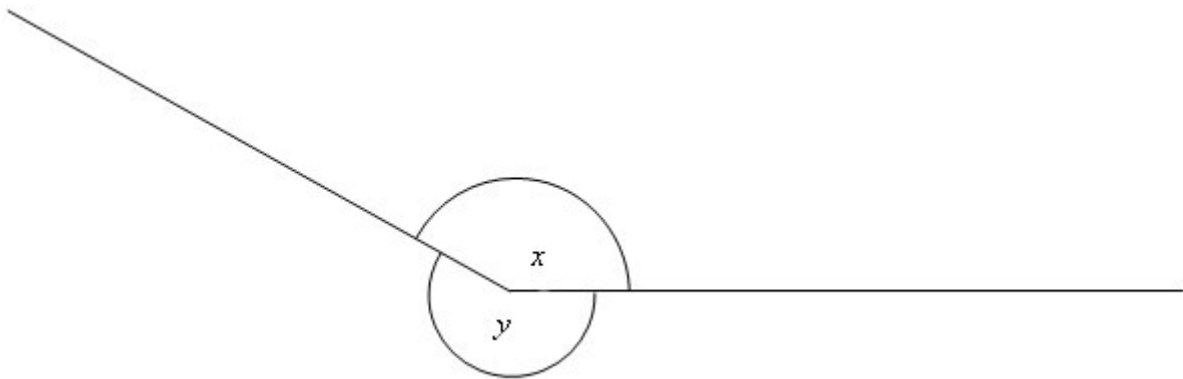

(a) Measure the size of the angle marked x .

.....° (1)

(b) What type of angle is shown by the letter y ?

..... (1)

(Total 2 marks)