

1MA0/4H
Edexcel GCSE
Mathematics (Linear) – 1MA0
Practice Paper 4H (Calculator)
Set C



Higher Tier

Time: 1 hour 45 minutes

Materials required for examination

Ruler graduated in centimetres and millimetres, protractor, compasses, pen, HB pencil, eraser.
Tracing paper may be used.

Items included with question papers

Nil

Instructions

Use black ink or ball-point pen.

Fill in the boxes at the top of this page with your name, centre number and candidate number.

Answer all questions.

Answer the questions in the spaces provided – there may be more space than you need.

Calculators may be used.

Information

The total mark for this paper is 100.

The marks for each question are shown in brackets – use this as a guide as to how much time to spend on **each** question.

Questions labelled with an **asterisk** (*) are ones where the quality of your written communication will be assessed – you should take particular care on these questions with your spelling, punctuation and grammar, as well as the clarity of expression.

Advice

Read each question carefully before you start to answer it.

Keep an eye on the time.

Try to answer every question.

Check your answers if you have time at the end.

GCSE Mathematics (Linear) 1MA0

Formulae: Higher Tier

**You must not write on this formulae page.
Anything you write on this formulae page will gain NO credit.**

Volume of prism = area of cross section \times length

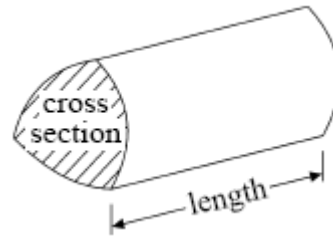

Volume of sphere $\frac{4}{3}\pi r^3$
Surface area of sphere = $4\pi r^2$

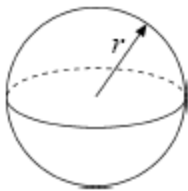

Volume of cone $\frac{1}{3}\pi r^2 h$
Curved surface area of cone = $\pi r l$

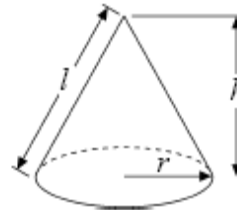

In any triangle ABC

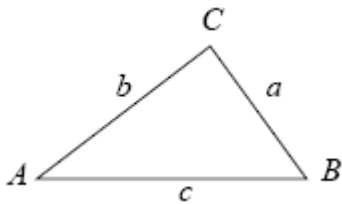

The Quadratic Equation

The solutions of $ax^2 + bx + c = 0$
where $a \neq 0$, are given by

$$x = \frac{-b \pm \sqrt{b^2 - 4ac}}{2a}$$

Sine Rule $\frac{a}{\sin A} = \frac{b}{\sin B} = \frac{c}{\sin C}$

Cosine Rule $a^2 = b^2 + c^2 - 2bc \cos A$

Area of triangle = $\frac{1}{2} ab \sin C$

Answer ALL TWENTY FOUR questions

Write your answers in the spaces provided.

You may use a calculator in this paper.

You must write down all the stages in your working.

1. Amy has organised a Christmas party for some children.
Each child will get a party bag.

Each party bag contains; 1 balloon,
 1 bar of chocolate,
 and 1 toy.

Amy buys some packets balloons. Each packet contains 10 balloons.
She buys some boxes of chocolate bars. Each box contains 18 chocolate bars.
She also buys some packets of toys. Each packet contains 12 toys.

Amy makes up all of the party bags.
There are no balloons, chocolate bars or toys left over.

Work out the least total number of party bags that Amy makes up.

.....
(3)

Only 90% of the children invited attend the party.

A packet of balloons costs £2.10
A box of bars of chocolate costs £4.50
A packet of toys costs £13.20

Work out the total cost of the contents of the party bags used.

£

(3)
(Total 6 marks)

2. Here are two trapeziums.

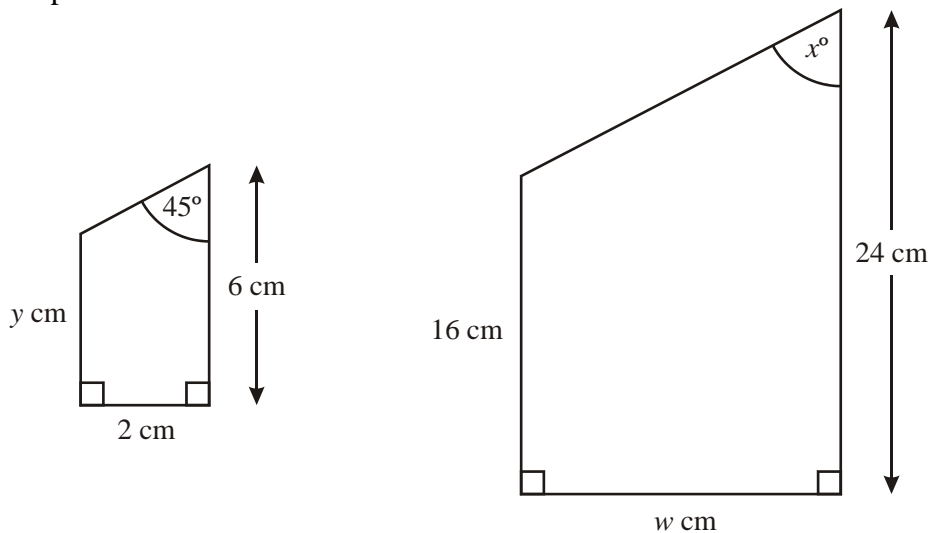

Diagram **NOT** accurately drawn

The larger trapezium is an enlargement of the smaller trapezium with a scale factor of 4

(a) Find the value of

(i) w ,

$w = \dots\dots\dots$

(ii) x ,

$x = \dots\dots\dots$

(iii) y .

$y = \dots\dots\dots$

(3)

(b) Work out the area of the larger trapezium.

$\dots\dots\dots \text{cm}^2$

(2)

(Total 5 marks)

*3. The diagram shows a wall in Vicky's living room.

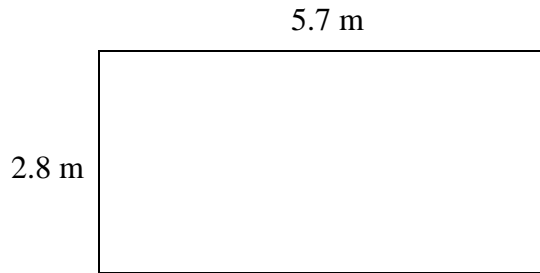

Diagram **NOT**
accurately drawn

Vicky plans to wallpaper this wall.
She buys some rolls of wallpaper.

Each roll of wallpaper is 53 cm wide and 12 m long.
The cost of one roll of wallpaper is £12.45

Work out the cost of wallpapering the wall.

£

(Total 5 marks)

4. (a) Factorise $p^2 + p$

.....

(1)

(b) Expand and simplify $4(x - 3) - 2(1 - x)$

.....

(2)

(Total 3 marks)

5. Angela earns £35 240 a year.

She has to pay income tax.

She is allowed to earn £6475 before paying tax.

She pays 20% tax on the rest.

Her employer deducts the income tax each month.

Work out how much income tax Angela gets deducted each month.

£

(Total 4 marks)

- *6. Jo wants buy a 50cc Retro Scooter.
She looks on the internet and sees these two advertisements.

Atlas Motor Cycles
50cc Retro Scooter



£649
plus delivery

Simpson's Scooters
50cc Retro Scooter



£629 + FREE delivery
up to 10 miles (delivery charge of
£2.50 for each mile over 10 miles.

This graph is used to calculate Atlas Motor Cycles delivery charge for different distances.
The delivery charge is made up of a fixed charge and a cost per mile.

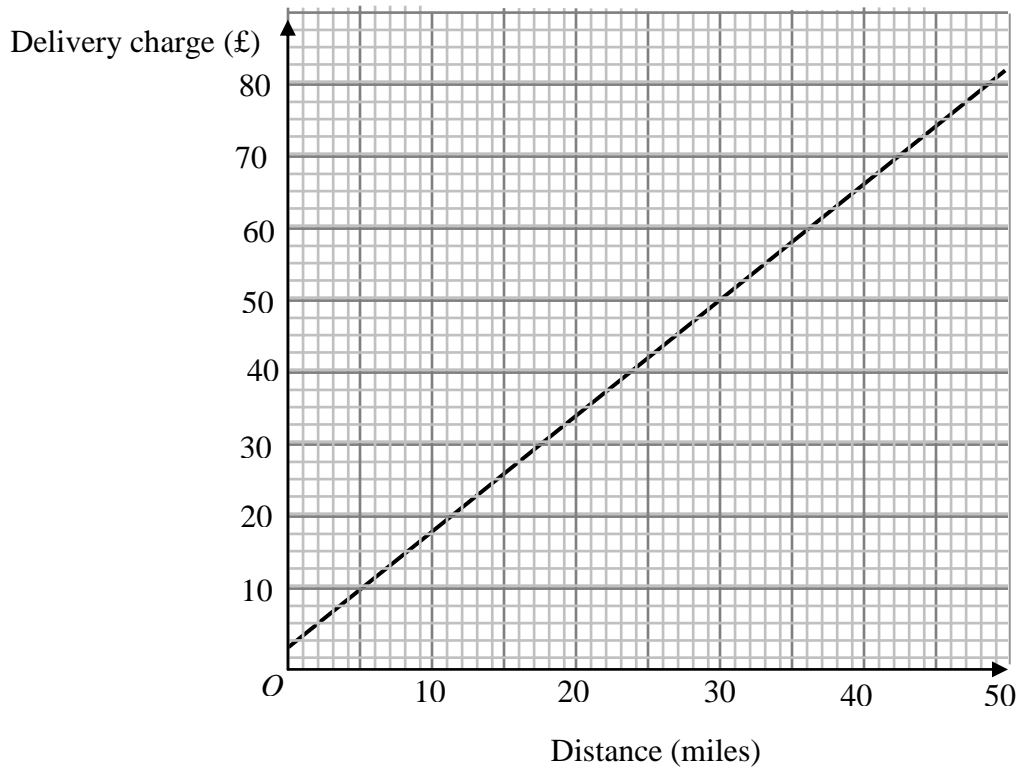

Jo lives 27 miles from Atlas Motor Cycles and 36 miles from Simpson's Scooters.

(a) Work out the most economical way for Jo to buy a 50cc Retro Scooter.

(5)

(b) Instead of giving a graph, what information could Atlas Motor Cycles have given to enable the delivery charge to be calculated?

(2)

(Total 7 marks)

7. Here is a rectangle.

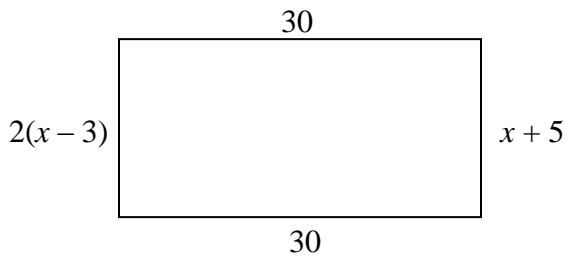

Diagram **NOT**
accurately drawn

All measurements are given in centimetres.

Find the perimeter of the rectangle.

..... cm
(Total 4 marks)

8. Marcus collected some pebbles.
He weighed each pebble.

The grouped frequency table gives some information about weights.

Weight (w grams)	Frequency		
$50 \leq w < 60$	5		
$60 \leq w < 70$	9		
$70 \leq w < 80$	22		
$80 \leq w < 90$	27		
$90 \leq w < 100$	17		

Work out an estimate for the mean weight of the pebbles.

..... grams

(Total 4 marks)

9. In a sale, normal prices are reduced by 12%.
The sale price of a DVD player is £242.
Work out the normal price of the DVD player.

£

(Total 3 marks)

10. Some students took a mathematics test and a science test.
The scatter graph shows information about the test marks of eight students.

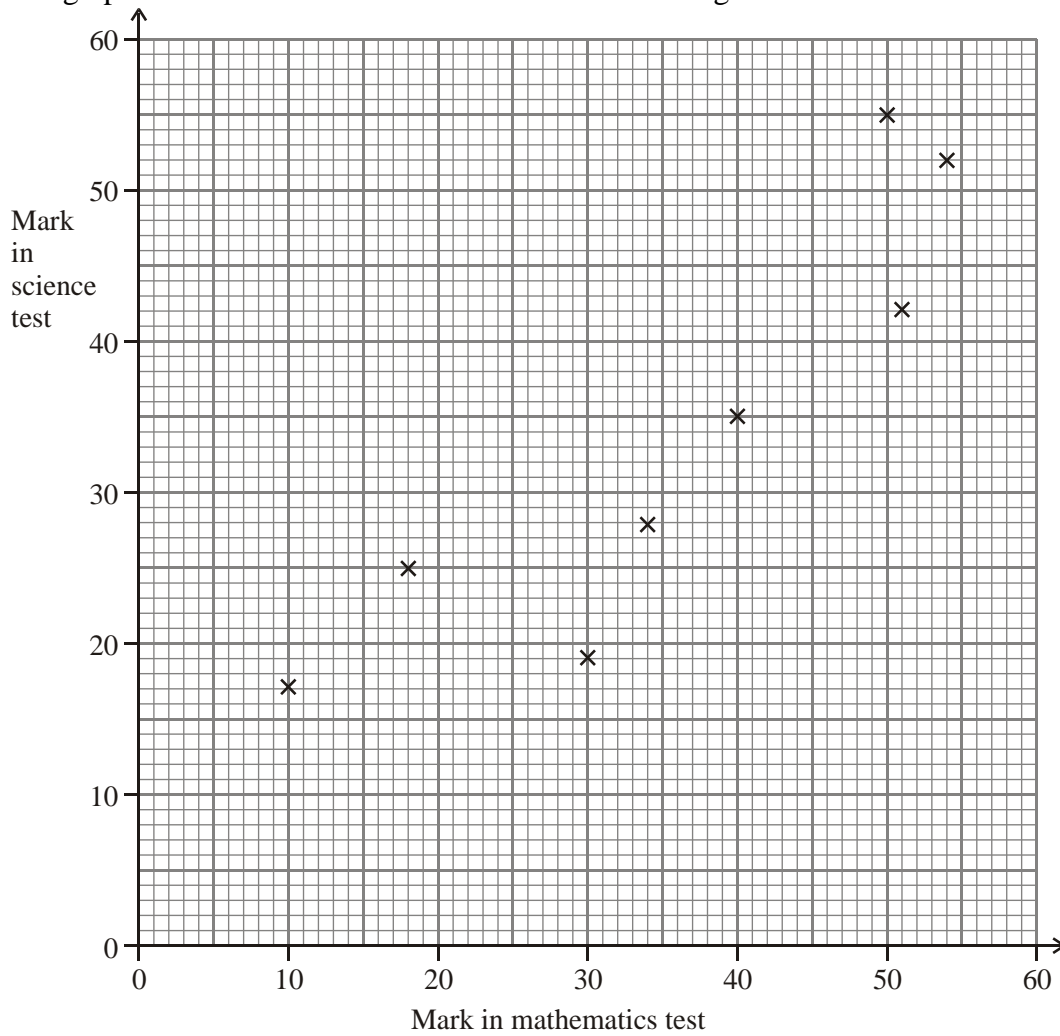

The table shows the test marks of four more students.

Mark in mathematics test	14	25	50	58
Mark in science test	21	23	38	51

- (a) On the scatter graph, plot the information from the table. (2)
- (b) Describe the correlation between the marks in the mathematics test and the marks in the science test.

..... (1)

Josef was absent for the mathematics test but his mark in the science test was 45

(c) Estimate Josef's mark in the mathematics test.

.....
(2)

(Total 5 marks)

11. A bag contains coloured counters.
The counters are either red or green or blue.

Kim takes at random a single counter from the bag.

The probability that she takes a red counter is 0.5
The probability that she takes a green counter is 0.15

(a) What is the probability that she takes a blue counter?

.....
(2)

A box contains 50 counters.
There are 23 white counters, 19 black counters and 8 yellow counters.

Zahid takes at random a single counter from the box.

(b) Work out the probability that he takes a white counter or a yellow counter.

.....
(2)

(Total 4 marks)

12. The cumulative frequency diagram below gives information about the prices of 120 houses.

(a) Find an estimate for the number of houses with prices less than £130 000

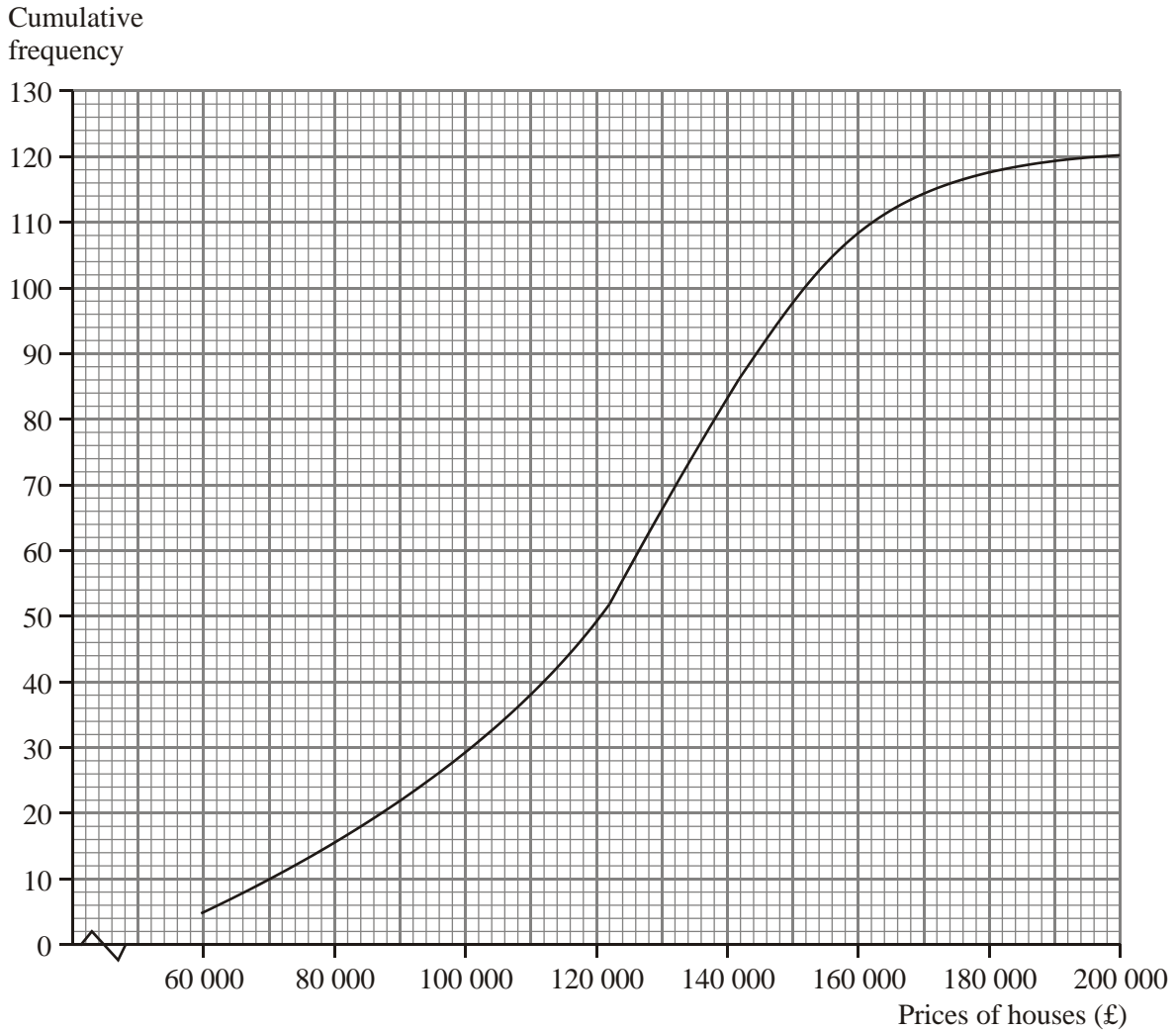

(b) Work out an estimate for the interquartile range of the prices of the 120 houses.

£
(2)

(Total 3 marks)

13. Make m the subject of the formula $3(p + m) = 1 - 4m$

$m = \dots\dots\dots$

(Total 3 marks)

14. (a) Simplify $15y^6 \div 3y^2$

$\dots\dots\dots$
(2)

(b) Simplify $7wx^2 \times (3w^3x)^2$

$\dots\dots\dots$
(2)

(Total 4 marks)

15.

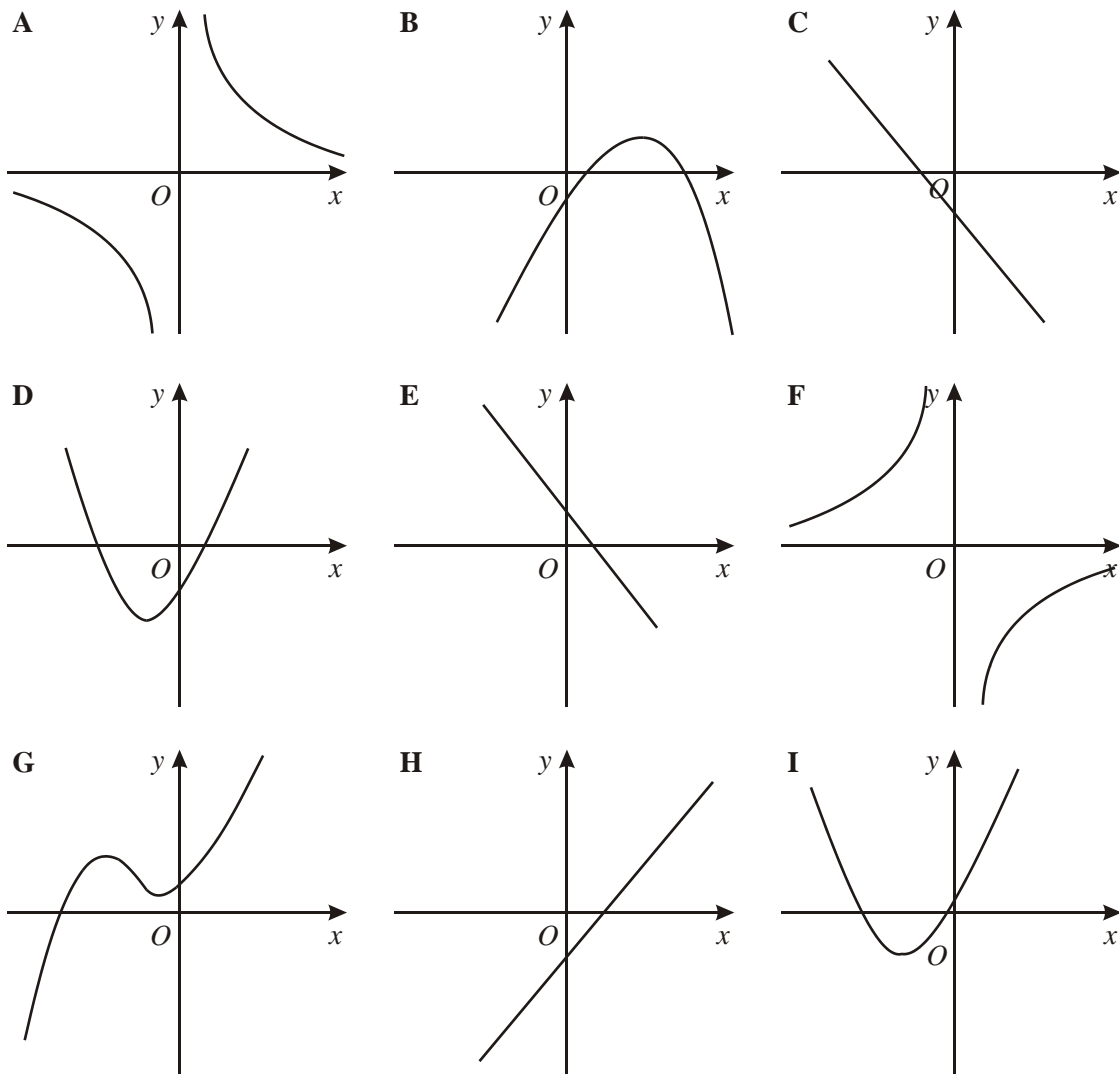

Write down the letter of the graph which could have the equation

(i) $y = 3x - 2$

.....

(ii) $y = 2x^2 + 5x - 3$

.....

(iii) $y = \frac{3}{x}$

.....

(Total 3 marks)

16.

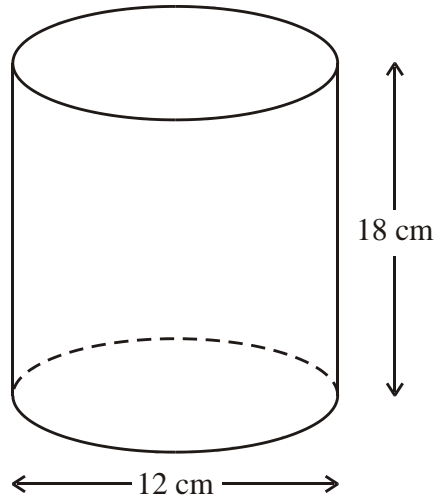

Diagram **NOT**
accurately drawn

The diagram shows a solid cylinder.

The cylinder has a diameter of 12 cm and a height of 18 cm.

Calculate the total surface area of the cylinder.
Give your answer correct to 3 significant figures.

..... cm²

(Total 3 marks)

17.

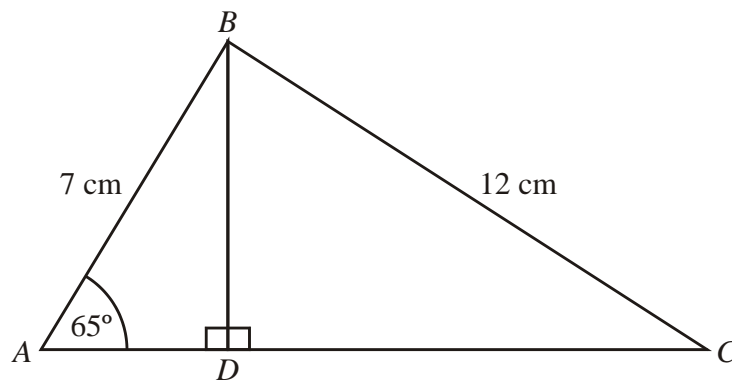

Diagram **NOT** accurately drawn

ABC is a triangle.
 ADC is a straight line with BD perpendicular to AC .
 $AB = 7$ cm.
 $BC = 12$ cm.
Angle $BAD = 65^\circ$.

Calculate the length of AC .
Give your answer correct to 3 significant figures.

..... cm
(Total 6 marks)

18. A straight line has equation $y = 3 - 5x$

(a) Write down the gradient of the line.

.....
(1)

The graphs of $y = 2x^2$ and $y = mx - 2$ intersect at the points A and B .
The point B has coordinates $(2, 8)$.

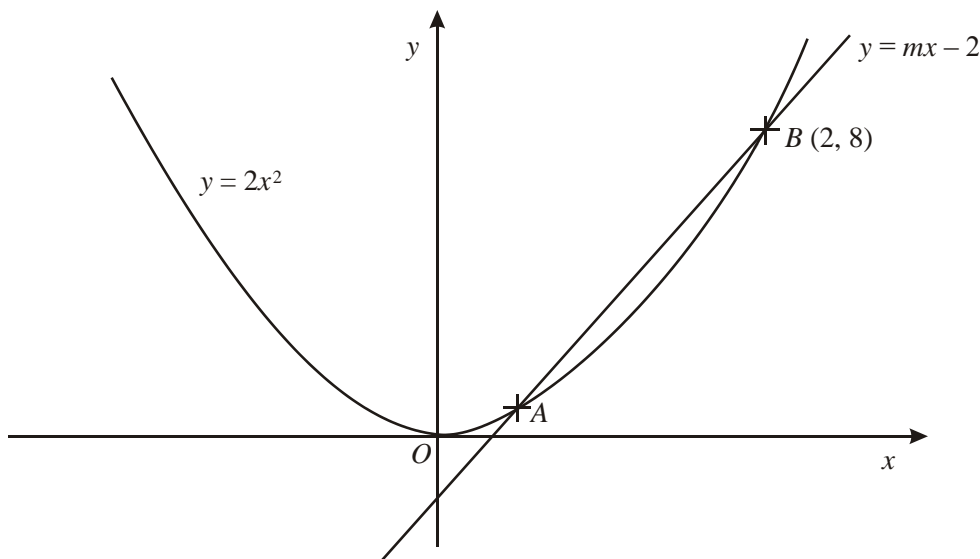

(b) Find the coordinates of the point A .

(..... ,)
(5)

(Total 6 marks)

19. The table shows the distribution of the ages of passengers travelling on a plane from London to Belfast.

Age (x years)	Frequency
$0 < x \leq 20$	28
$20 < x \leq 35$	36
$35 < x \leq 45$	20
$45 < x \leq 65$	30

On the grid below, draw a histogram to show this distribution.

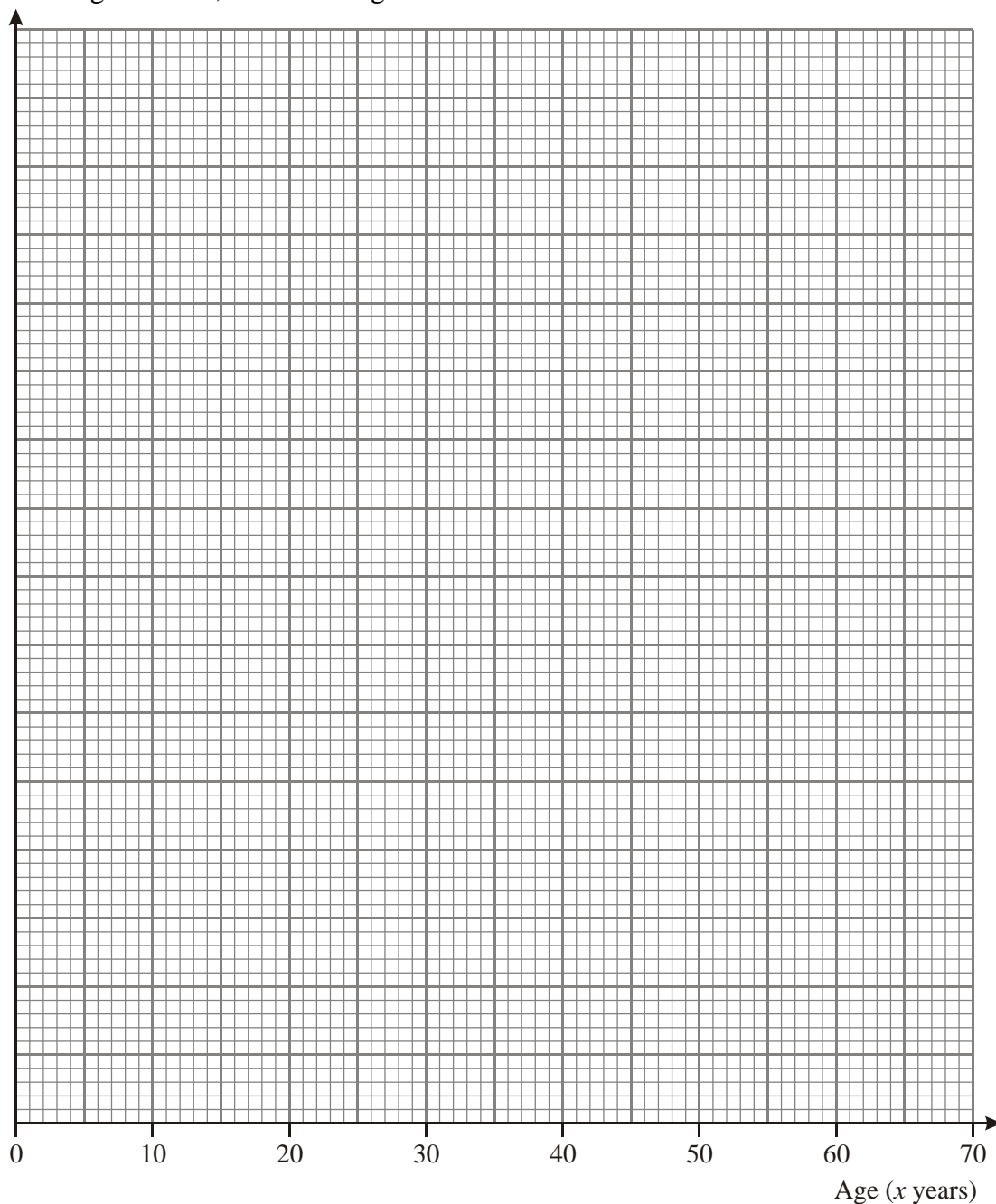

(Total 3 marks)

20.

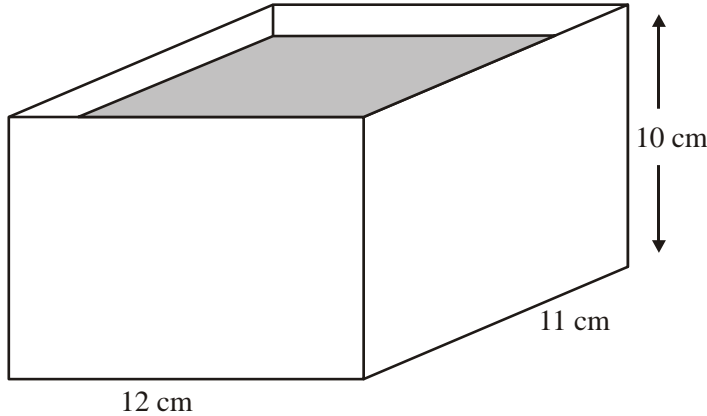
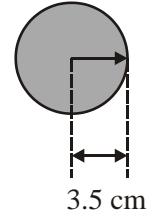

Diagram **NOT** accurately drawn



A rectangular container is 12 cm long, 11 cm wide and 10 cm high. The container is filled with water to a depth of 8 cm.

A metal sphere of radius 3.5 cm is placed in the water. It sinks to the bottom.

Calculate the rise in the water level.
Give your answer correct to 3 significant figures.

.....cm

(Total 4 marks)

21. The table shows some information about the pupils at Statson School.

Year group	Boys	Girls	Total
Year 7	104	71	175
Year 8	94	98	192
Year 9	80	120	200
Total	278	289	567

Kelly carries out a survey of the pupils at Statson School. She takes a sample of 80 pupils, stratified by both Year group and gender. Work out the number of Year 8 boys in her sample.

.....
(Total 2 marks)

*22.

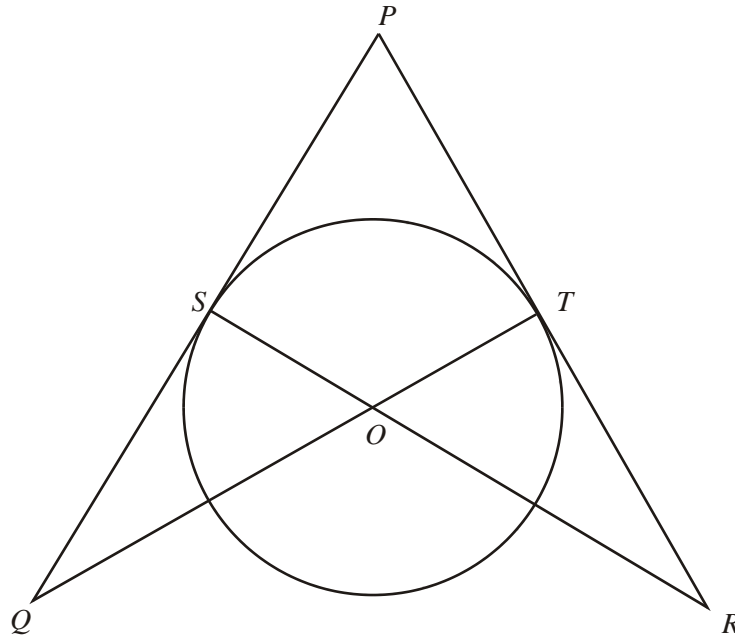

Diagram **NOT**
accurately drawn

S and T are points on a circle, centre O .
 PSQ and PTR are tangents to the circle.
 SOR and TOQ are straight lines.

Prove that triangle PQT and triangle PRS are congruent.

(Total 3 marks)

23. A clay bowl is in the shape of a hollow hemisphere.

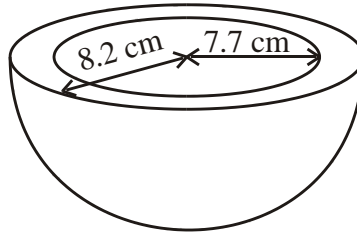

Diagram **NOT**
accurately drawn

The external radius of the bowl is 8.2 cm.

The internal radius of the bowl is 7.7 cm.

Both measurements are correct to the nearest 0.1 cm.

The upper bound for the volume of the clay is $k\pi \text{ cm}^3$.

Find the exact value of k .

$k = \dots\dots\dots$

(Total 4 marks)

24. Solve the simultaneous equations

$$x + y = 4$$

$$x^2 + y^2 = 40$$

$$x = \dots\dots\dots, y = \dots\dots\dots$$

or

$$x = \dots\dots\dots, y = \dots\dots\dots$$

(Total 6 marks)

TOTAL FOR PAPER: 100 MARKS

END