

SECTION A

Answer ALL questions in this section.

1. Figure 1. shows two bar magnets placed with the south poles close together

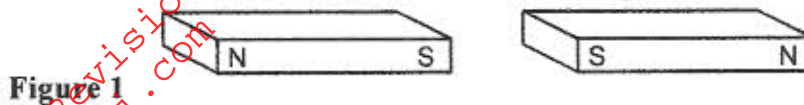

In Figure 1 sketch the magnetic field pattern between the two south poles (1 mark)

2. In a certain pinhole camera, the screen is 10cm from the pinhole. When the camera is placed 6m away from a tree, a sharp image of the tree 16cm high is formed on the screen. Determine the height of the tree. (3 marks)

3. A metallic body shaped as shown in Figure 2. is positively charged and insulated from the ground as shown in the figure.

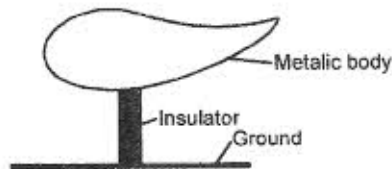

Figure 2

On the figure show the charged distribution. (1 mark)

4. State a reason why the caps of the cells of a lead-acid battery are opened when charging the battery (1 mark)
5. A long coil is attached to a vibrating blade as shown in Figure 3.

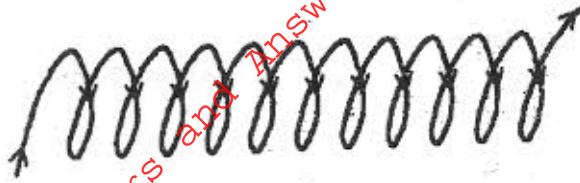

Figure 3.

State the type of mechanical wave generated by the set-up and mark alongside the coil. The length corresponding to the wavelength, λ , of the wave. (2 marks)

6. **Figure 4.** shows a solenoid carrying an electric current.

Figure 4.



Sketch the magnetic field pattern inside and at the ends of the solenoid (1 mark)

7. **Figure 5.** shows wavefronts approaching a concave surface

Figure 5.

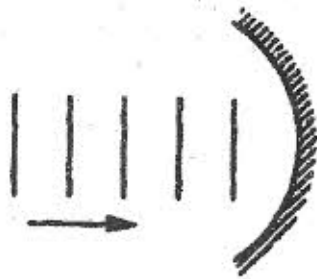

Complete the diagram to show the wavefronts formed after striking the surface. Show how the focal point of the surface is located. (2 marks)

8. A soldier standing some distance from a wall, blows a whistle and hears its echo 1.8 seconds later. How far is the wall from the soldier? (Speed of sound in air is 330ms^{-1}) (3 marks)
9. State one condition under which Ohm's law is obeyed in a metal conductor (1 mark)

Use the information given below to answer questions 10 and 11.

The Kinetic energy (K.E) of an electron, ejected from the surface of a metal illuminated by radiation of frequency, f is given by

$$\text{K.E.} = hf - \theta$$

where h is Planck's constant and θ is the work function of the surface.

10. What is meant by the term work function? (1 mark)

11. In the frequency of the illuminating radiation is just equal to the threshold frequency of the surface. Explain why no photoelectric effect is observed. (2 marks)

Figure 6. shows a tube for investigating the properties of a beam of electrons. Use the information in the figure to answer questions 12 and 13.

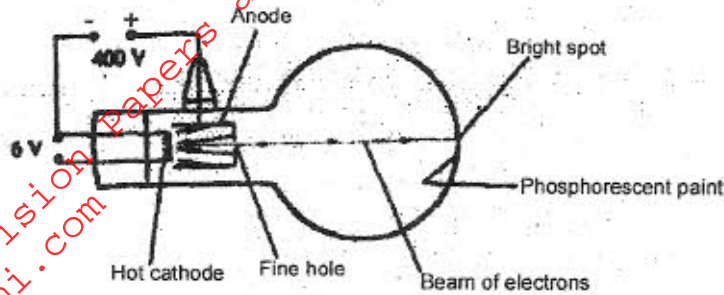
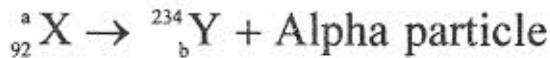

Figure 6.

12. What property of the beam of electrons show that the electrons are travelling at a very high speed? (1 mark)
13. The beam of electrons is subjected to a strong uniform magnetic field which is perpendicular to the path and into the paper. Sketch on the same figure, the new path of electrons. (1 mark)
14. State with a reason the effect on the X-rays produced in an X-ray tube, when the p.d across the tube is increased. (2 marks)
15. A nuclear reaction is represented by the following equation.



(2 marks)

Determine the values of a and b.

16. In an axes provided sketch the current-voltage characteristics for a reverse-biased p - n junction. (1 mark)

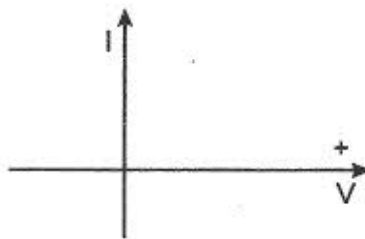

SECTION B

Answer ALL questions in this section.

17. Figure 7. shows a circuit where a battery of emf 4.5V, switches A and B, two capacitors $C_1 = 0.3\mu\text{F}$ and $C_2 = 0.5\mu\text{F}$ and a voltmeter are connected.

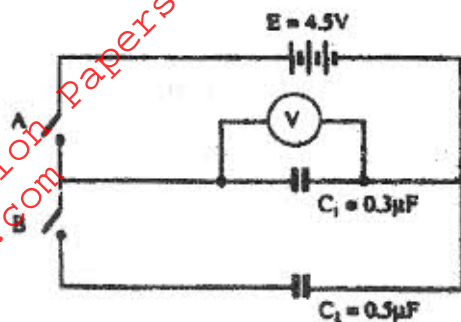
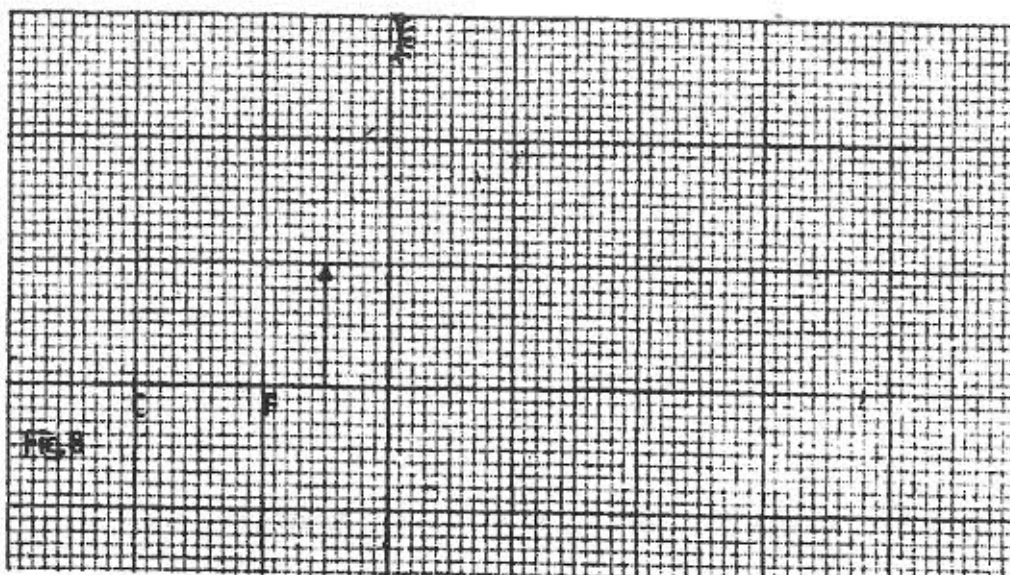

Figure 7.

- (a) Determine the charge on C_1 when switch A is closed and switch B is open. (3 marks)
- (b) What is the effective capacitance C_T when both switches A and B are closed? (2 marks)
- (c) State what is observed on the voltmeter when
- (i) Switch A is closed and switch B is open (1 mark)
 - (ii) Switch A is closed and opened, and then B is closed (1 mark)
 - (iii) Explain the observation made in c (ii) above (2 marks)
18. Figure 8. shows an object placed in front of a concave mirror of focal length 10cm. C is the centre of curvature.



- (i) On the same figure draw a ray diagram showing the location of the image (4 marks)

Use the ray diagram drawn in (i) above to determine the

- (ii) image distance (2 marks)
(iii) magnification (2 marks)

- (b) A vertical object is placed 20cm in front of a convex lens of focal length 5 cm.

- (i) Determine
I the image distance (3 marks)

II the magnification (2 marks)

- (ii) State two characteristics of the image (2 marks)

19. (a) Define the refractive index of a substance (1 mark)

- (b) In an experiment to determine the refractive index of a liquid, the liquid was poured into a measuring cylinder. A pin was placed at the bottom of the cylinder and another pin was used to locate the apparent position of the first pin. The real depth and apparent depth were measured. The experiment was repeated with other values of real depth. The table below shows the results obtained.

Real depth (cm)	5	10	15	20	25
Apparent depth (cm)	3.3	6.7	10	13.3	16.7

- (i) Plot the graph of real depth against apparent depth (5 marks)

- (ii) From the graph determine the refractive index of the liquid (4 marks)

- (c) **Figure 9.** Shows a ray of light incident on a glass-air interface.

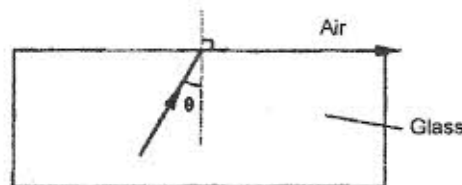

- Given that the refractive index of the glass is 1.6, determine angle θ . (3 marks)

20. **Figure 10.** shows a simple electric generator.

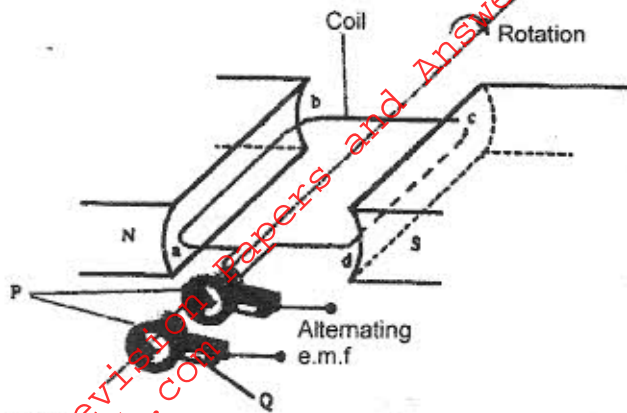

Figure 10

(a) (i) Name the parts labelled P and Q (2 marks)

(ii) The emf generated as the coil rotates is represented in the graph in **Figure 11.**

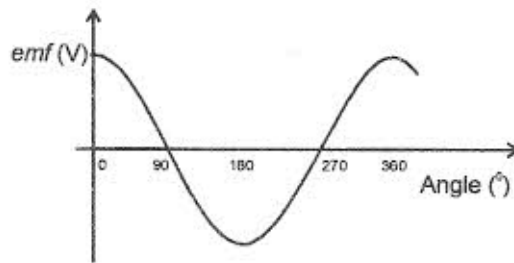

Figure 11

Give reasons for the changes in the emf as the coil rotates from 0° to 90° and 90° to 180° (3 marks)

(b) The primary coil of a transformer has 1200 turns and the secondary coil has 60 turns. The transformer is connected to a 240V a.c. source.

Determine

(i) The output voltage (2 marks)

(ii) The output current when the primary coil has a current of 0.5 A (Assume there are no energy losses) (3 marks)

21. (a) Figure 12. shows a section of a house wiring system.

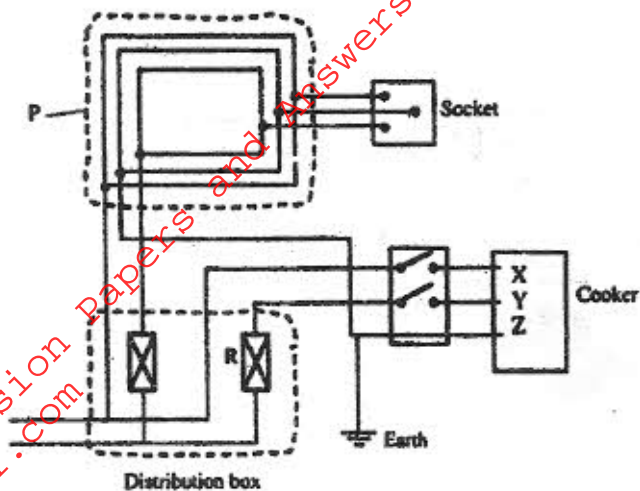

Figure 12.

(i) Name:

The circuit labelled P _____ (1 mark)

The terminals labelled X and Y.

X _____ Y _____ (2 marks)

(ii) I State the purpose of R in the circuit (1 mark)

II Give a reason why R is connected to Y but not to X (1 mark)

(iii) Why is the earthing necessary in such a circuit? (1 mark)

(b) Determine the cost of using an electric iron rated 1500W, for a total of 30 hours given that the cost of electricity per kWh is Ksh.8 (2 marks)