

K.C.S.E. MATHEMATICS PAPER 121/1 2004

SECTION I (52 marks)

Answer *all* the questions in this section

1. Without using logarithm tables, evaluate

$$\frac{0.015 + 0.45 + 1.5}{4.9 \times 0.2 + 0.07}$$

giving the answer in decimal form.

(2 marks)

2. The size of an interior angle of a regular polygon is 156° . Find the number of sides of the polygon.

(2 marks)

3. Simplify the expression:

$$\frac{2a^2 - 3ab - 2b^2}{4a^2 - b^2}$$

(3 marks)

4. Point C divides the line AB given below externally in the ration 5 : 2

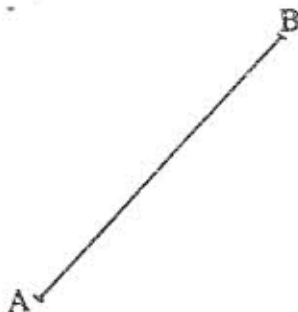

By construction, determine the position of point C.

(3 marks)

5. Use tables of reciprocals only to work out

$$\frac{3}{0.6735} + \frac{13}{0.156}$$

(3 marks)

6. In the figure below PQRS is a trapezium with SR parallel to PQ. SR = 5 cm, RQ = 4 cm, QS = 8 cm and PQ = 10 cm.

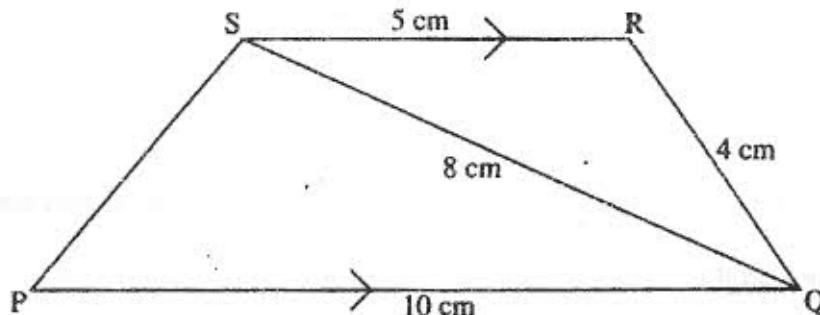

Calculate:

- (a) the size of angle QSR

(2 marks)

- (b) the area of triangle PQS

(2 marks)

7. The figure below represents a hexagonal prism whose height is 20 cm. The cross-section of the prism is a regular hexagon of side 5 cm.

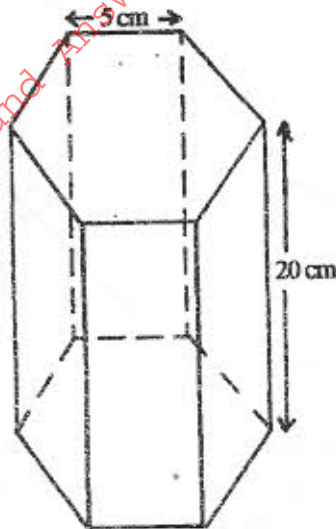

Find the volume of the prism.

(4 marks)

8. The figure below shows a circle, centre O, of radius 7 cm. TP and TQ are tangents to the circle at points P and Q respectively. OT = 25 cm.

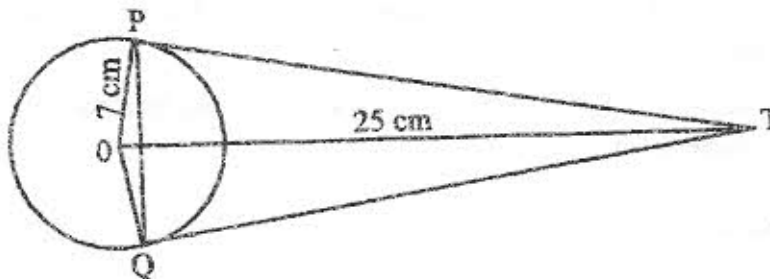

Calculate the length of the chord PQ

(3 marks)

9. P(5, -4) and Q(-1, -2) are points on a straight line. Find the equation of the perpendicular bisector of PQ; giving the answer in the form $y = mx + c$

(4 marks)

10. Use logarithms to evaluate $\frac{34.33}{\sqrt{5.25 \times 0.042}}$

(4 marks)

11. The marked price of a car in a dealer's shop was sh. 400 000. Wekesa bought the car at 8% discount. The dealer still made a profit of 15%. Calculate the amount of money the dealer had paid for the car.

(3 marks)

12. Two trains T_1 and T_2 travelling in opposite directions, on parallel tracks, are just beginning to pass one another. Train T_1 is 72m long and is travelling at 108 km/h. T_2 is 78 m long and is travelling at 72km/h. Find the time, in seconds, the two trains take to completely pass one another.

(4 marks)

13. A group of 5 people can do a piece of work in 6 hours. Calculate the time a group of 8 people, working at half the rate of the first group would take to complete the same work.

(3 marks)

14. In the figure below ABCDE is a cross-section of a solid. The solid has uniform cross-section. Given that BG is a base edge of the solid, complete the sketch, showing the hidden edges with broken lines. (3 marks)

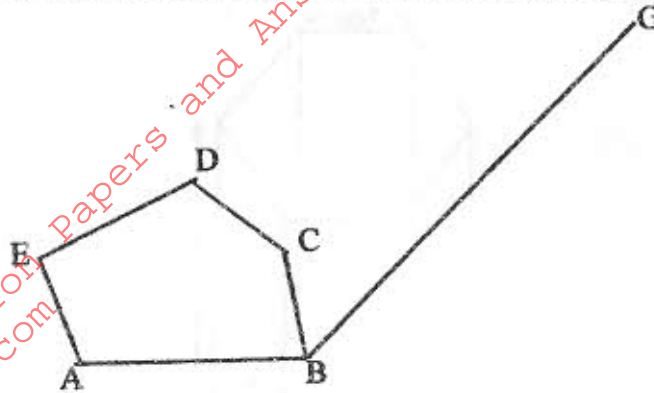

15. In this question, mathematical tables should not be used.
A Kenyan bank buys and sells foreign currencies as shown below:

	Buying (Kenya shillings)	Selling (Kenya shillings)
1 Euro	84.15	84.26
100 Japanese yen	65.37	65.45

A Japanese travelling from France arrives in Kenya with 5000 Euros. He converts all the 5000 Euros to Kenya shilling at the bank.

While in Kenya he spends a total of Kenya shillings 289 850 and then converts the remaining Kenya shillings to Japanese yen at the bank.

Calculate the amount in Japanese yen, that he receives. (4marks)

16. Form the three inequalities that satisfy the given region R. (3marks)

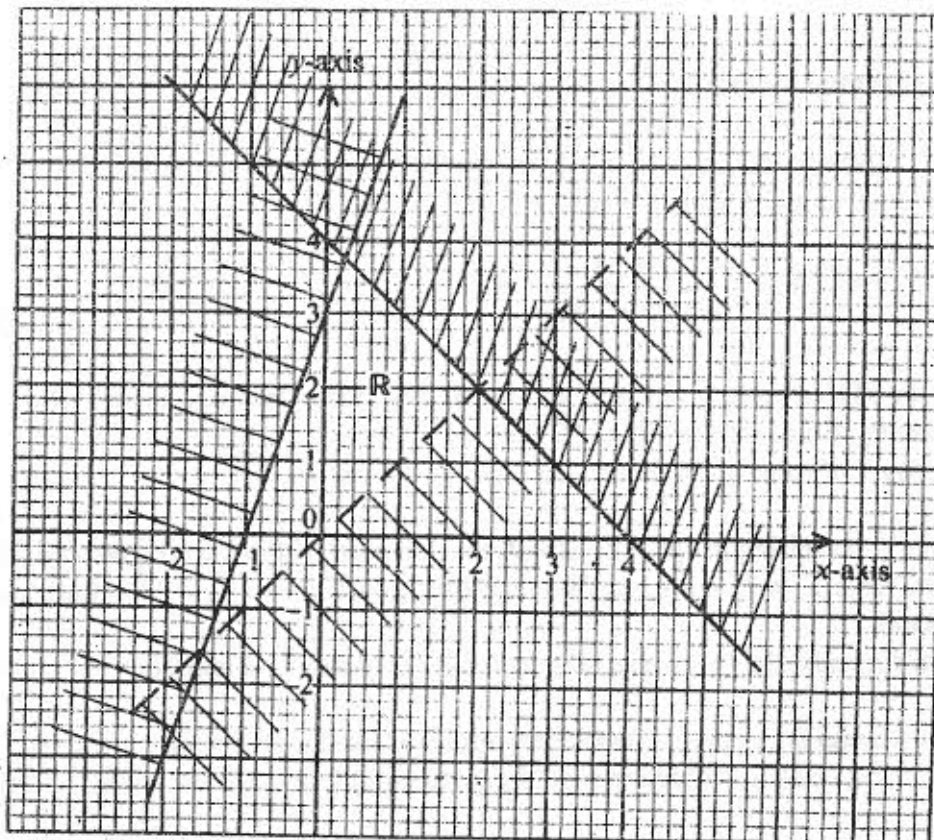

SECTION II

Answer any six questions from this section

17. The figure below represents a model of a solid structure in the shape of a frustum of a cone with a hemispherical top.

The diameter of the hemispherical part is 70 cm and is equal to the diameter of the top of the frustum. The frustum has a base diameter of 28 cm and slant height of 60 cm.

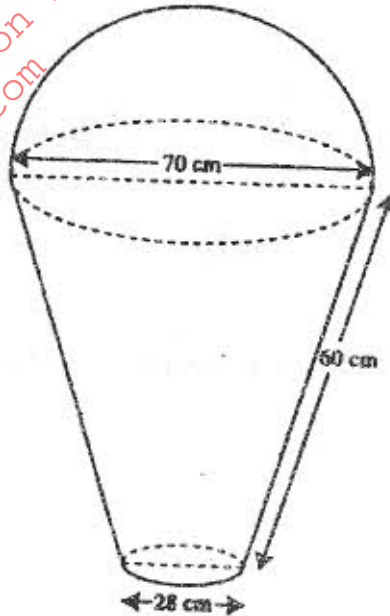

Calculate:

- (a) the area of the hemispherical surface (2 marks)
- (b) the slant height of the cone from which the frustum was cut (2 marks)
- (c) the total surface area of the model. (4 marks)
18. The simultaneous equation below, are satisfied when $x = 1$ and $y = p$.
- $$-3x + 47 = 5$$
- $$qx^2 - 5xy + y^2 = 0$$
- (a) Find the values of p and q . (4 marks)
- (b) Using the value of q obtained in (a) above, find the other values of x and y which also satisfy the given simultaneous equations. (4 marks)
19. A triangular plot ABC is such that the length of the side AB is two thirds that of BC. The ratio of the lengths AB : AC = 4 : 9 and the angle at B is obtuse.
- If the perimeter of the plot is 38 m, calculate
- (a) the length of the side BC (3 marks)
- (b) (i) the area of the plot (3 marks)
- (ii) the size of $\angle ABC$ (2 marks)

20. A farmer has two tractors A and B. The tractors, working together can plough a farm in $2\frac{1}{2}$ h. One day, the tractors started to plough the farm together. After 1 h 10 min, tractor B broke down but A continued alone and completed the job after a further 4 h.

Find:

- (a) the fraction of the job done by the tractors, working together for one hour (1 mark)
- (b) the fraction of the job done by tractor A after B broke down (3 marks)
- (c) the time each tractor working alone would have taken to plough the farm. (4 marks)

21. Four electricity posts A, B, C and D stands on a level ground such that B is 21m on a bearing of 060° from A, C is 15m to the south of B and D is 12m on a bearing of 140° from A.

- (a) (i) Using a scale of 1 cm to represent 3 metres, draw a diagram to show the relative positions of the posts. (3 marks)
- (ii) Find the distance and the bearing of C from D. (2 marks)
- (b) The height of the post at A is 8.4m. On a separate scale drawing, mark and determine the angle of depression of the foot of the post at C from the top of the post at A. (3marks)