

Ma

KEY STAGE
3

TIER
6–8

2005

Mathematics test

Paper 1

Calculator not allowed

Please read this page, but do not open your booklet until your teacher tells you to start. Write your name and the name of your school in the spaces below.

First name _____

Last name _____

School _____

Remember

- The test is 1 hour long.
- You **must not** use a calculator for any question in this test.
- You will need: pen, pencil, rubber, ruler and a pair of compasses.
- Some formulae you might need are on page 2.
- This test starts with easier questions.
- Try to answer all the questions.
- Write all your answers and working on the test paper – do not use any rough paper. Marks may be awarded for working.
- Check your work carefully.
- Ask your teacher if you are not sure what to do.

For marker's
use only

Total marks

--

Instructions

Answers



This means write down your answer or show your working and write down your answer.

Calculators



You **must not** use a calculator to answer any question in this test.

Formulae

You might need to use these formulae

Trapezium

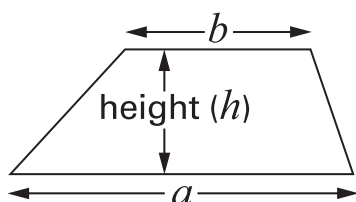

$$\text{Area} = \frac{1}{2}(a + b)h$$

Prism

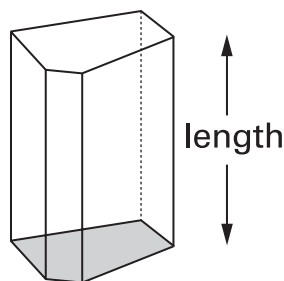

$$\text{Volume} = \text{area of cross-section} \times \text{length}$$

1. (a) P is the **midpoint** of line AB.

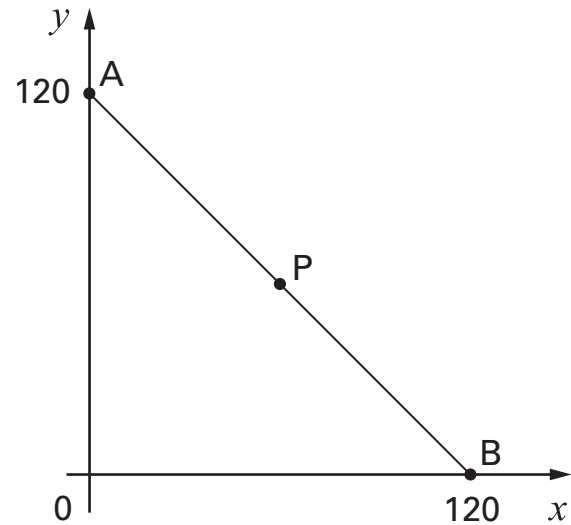

What are the coordinates of point P?



P is (..... ,)

.....
1 mark

- (b) Q is the **midpoint** of line MN.

The coordinates of Q are (30, 50)

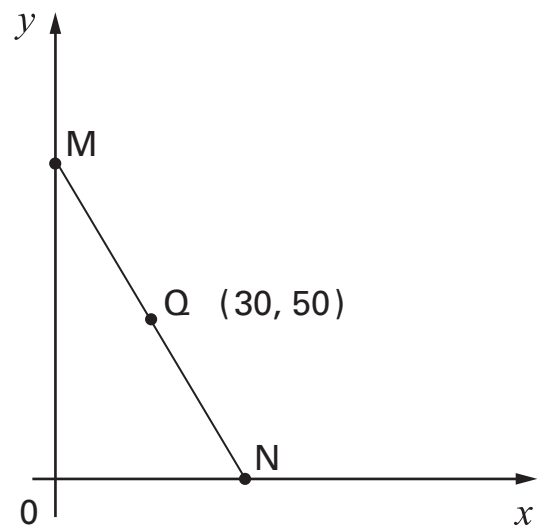

What are the coordinates of points M and N?



M is (..... ,)

.....
1 mark

N is (..... ,)

.....
1 mark



2. The diagram shows a **square**.
 Two straight lines cut the square into four rectangles.
 The area of one of the rectangles is shown.

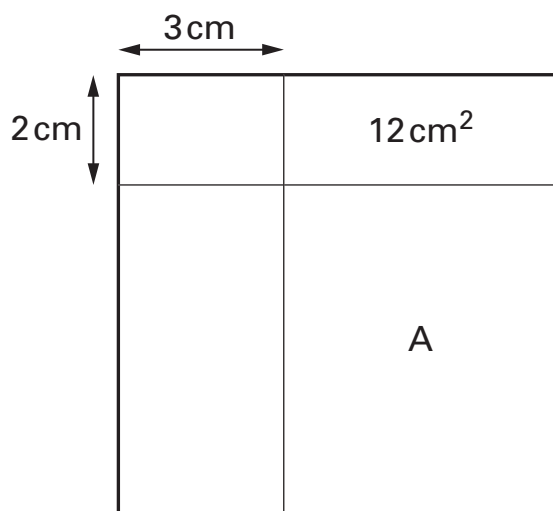

Not drawn accurately

Work out the area of the rectangle marked A.



..... cm²

.....

 2 marks

3. (a) Look at this information.

Two numbers **multiply** to make zero.

One of the statements below is true.

Tick (✓) the true statement.



- Both numbers must be zero.
- At least one number must be zero.
- Exactly one number must be zero.
- Neither number can be zero.

.....
1 mark

(b) Now look at this information.

Two numbers **add** to make zero.

If **one** number is **zero**, what is the other number?



.....

.....
1 mark

If **neither** number is **zero**, give an example of what the numbers could be.



..... and

.....
1 mark



4. I join six cubes face to face to make each 3-D shape below.

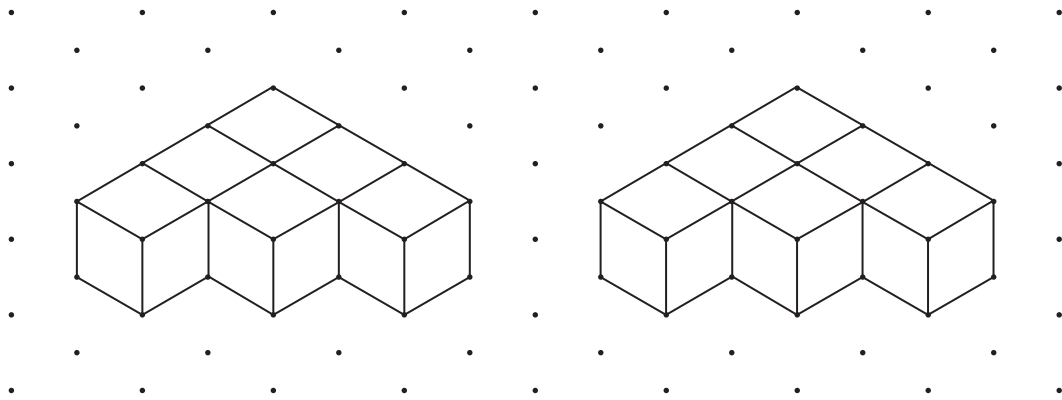

Isometric grid

Then I join the 3-D shapes to make a **cuboid**.

Draw this cuboid on the grid below.

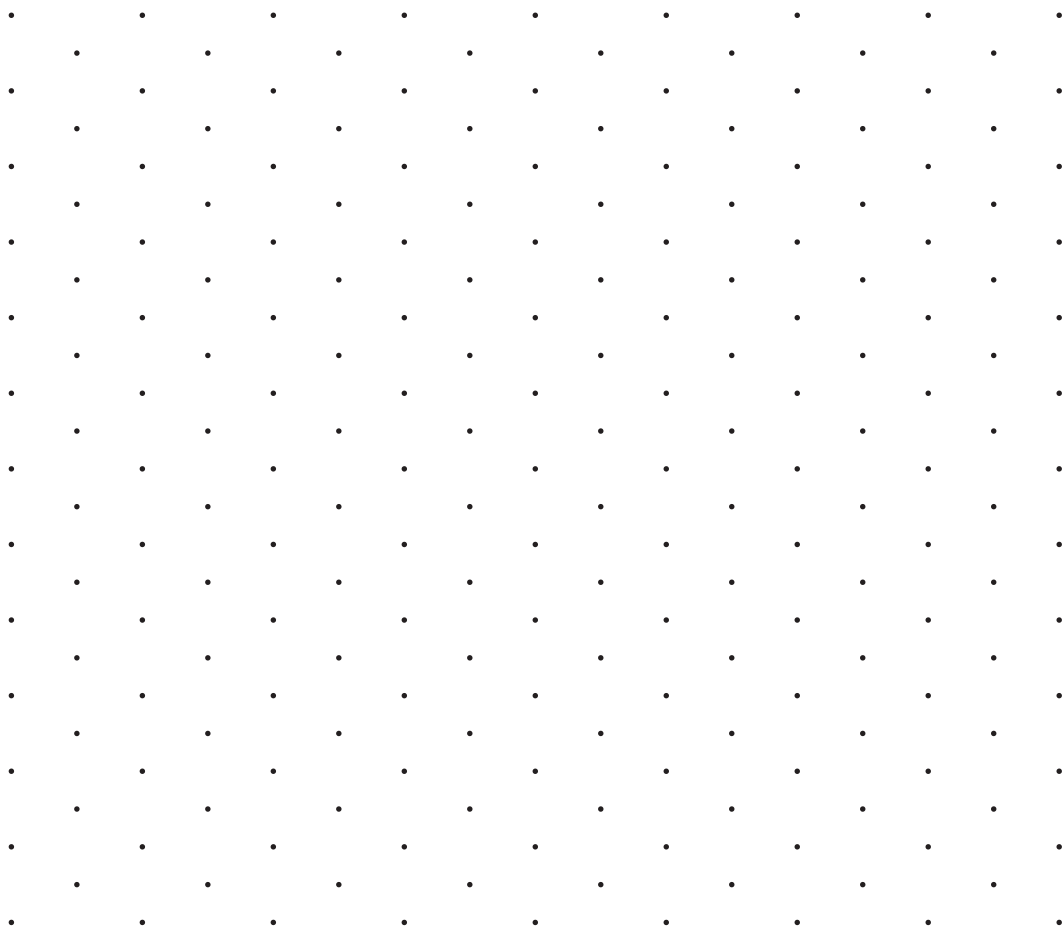

2 marks

Isometric grid

5. How many eighths are there in one quarter?



.....

Now work out $\frac{3}{4} \div \frac{1}{8}$



.....

 3 marks

6. Solve this equation.

$$75 + 2t = 100 - 2t$$



$t =$

.....

 2 marks



7. This shape has been made from two congruent **isosceles** triangles.

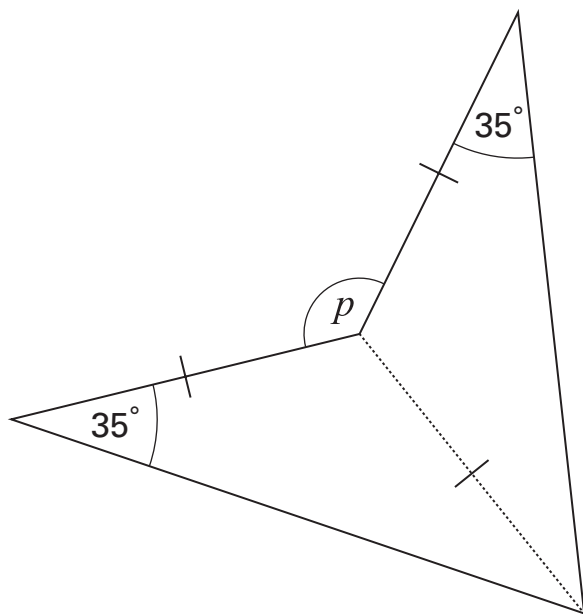

Not drawn accurately

What is the size of angle p ?



$p = \dots\dots\dots^\circ$

.....
.....
2 marks

8. Bumps are built on a road to slow cars down.

The stem-and-leaf diagrams show the speed of **15 cars** before and after the bumps were built.

Key:

2 | 3 means 23 mph

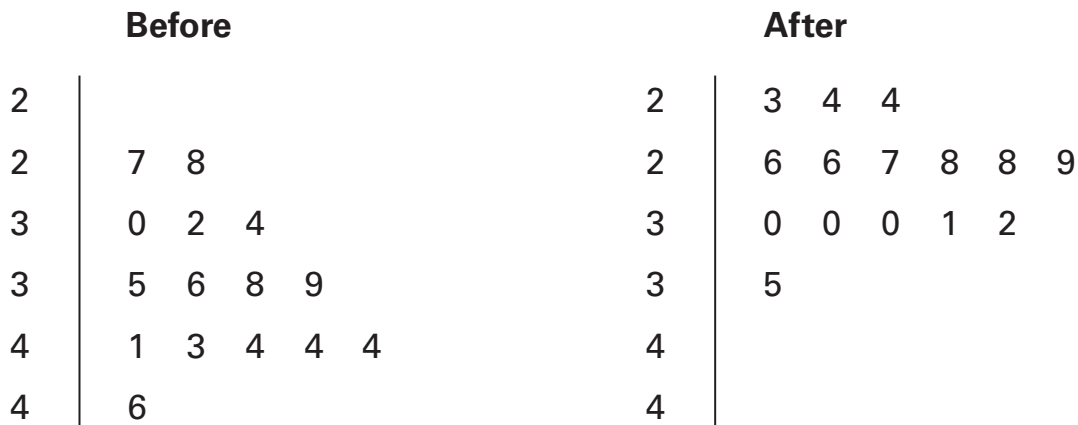

- (a) Use the diagrams to write the missing **numbers** in these sentences.



Before the bumps:

The maximum speed was mph, and
 cars went at more than 30mph.

After the bumps:

The maximum speed was mph, and
 cars went at more than 30mph.

.....

 2 marks

- (b) Show that the **median** speed fell by 10 mph.



.....

 1 mark

9. The graph shows the straight line with equation $y = 3x - 4$

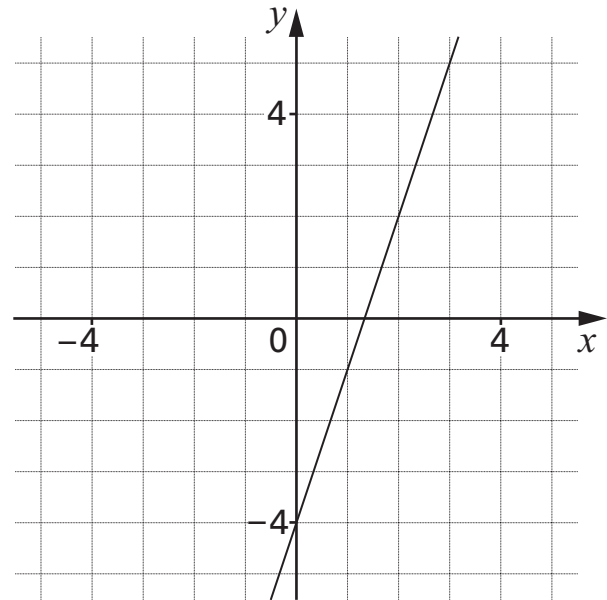

- (a) A point on the line $y = 3x - 4$ has an **x -coordinate of 50**
What is the y -coordinate of this point?



.....

.....
1 mark

- (b) A point on the line $y = 3x - 4$ has a **y -coordinate of 50**
What is the x -coordinate of this point?



.....

.....
1 mark

- (c) Is the point $(-10, -34)$ on the line $y = 3x - 4$?



Yes

No

Show how you know.



.....
1 mark

10. Here is an equation.

$$x^y = 64$$

Give four **different** pairs of values that satisfy this equation.



First pair	$x = \dots\dots\dots$	$y = \dots\dots\dots$
Second pair	$x = \dots\dots\dots$	$y = \dots\dots\dots$
Third pair	$x = \dots\dots\dots$	$y = \dots\dots\dots$
Fourth pair	$x = \dots\dots\dots$	$y = \dots\dots\dots$

.....
.....
.....
3 marks

11. A teacher said to a pupil:

To the nearest per cent, $\frac{1}{6}$ is **17%**

The pupil said:

So, to the nearest per cent, $\frac{2}{6}$ must be **34%**

Show that the pupil is **wrong**.



1 mark

12. Car tyres are checked for safety by measuring the tread.

The tread on a tyre and the distance travelled by that tyre were recorded for a sample of tyres. The scatter graph shows the results.

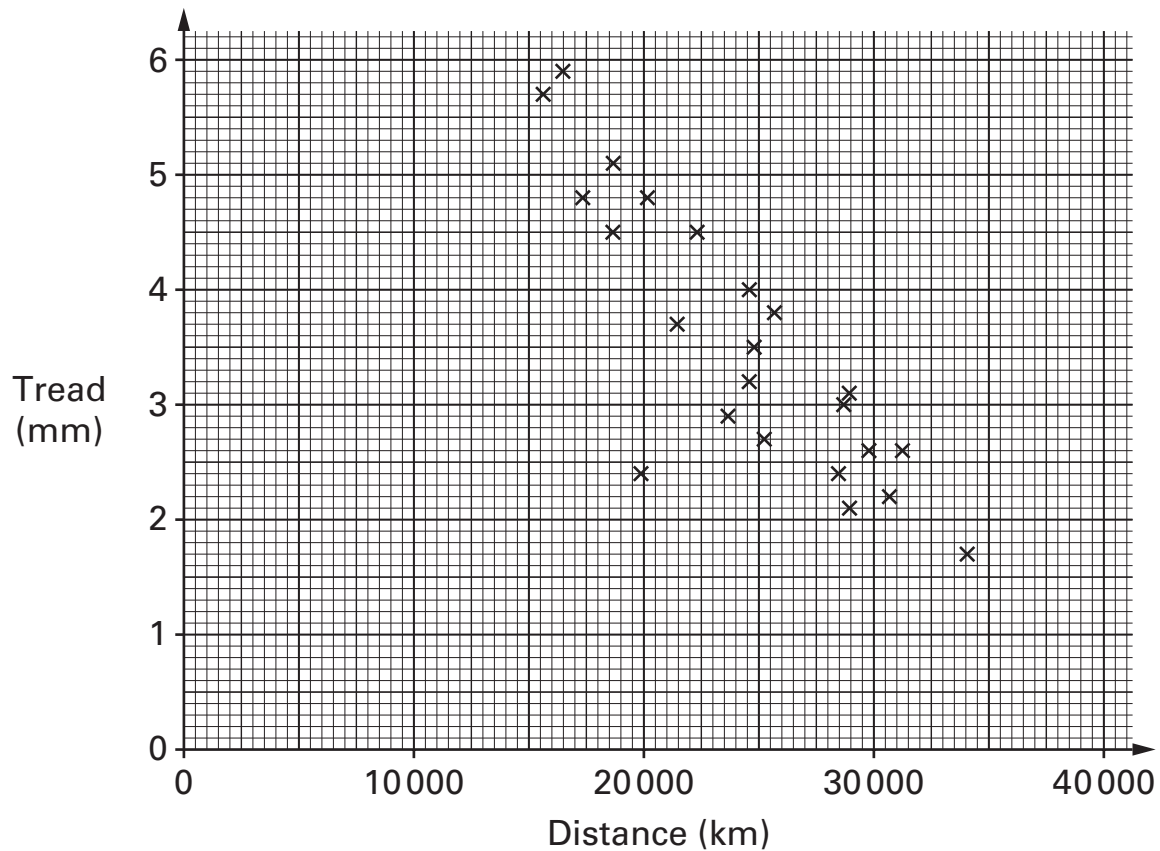

Tyres with a tread of **less than 1.6mm** are illegal.

Suppose the government changes this rule to **less than 2.5mm**.

- (a) How many of these tyres would now be illegal?



.....

1 mark

- (b) About **how many fewer kilometres** would you expect a tyre to last before it was illegal?



.....

1 mark



13. (a) In which triangle below does $a^2 + b^2 = c^2$?

Tick (✓) the correct triangle.

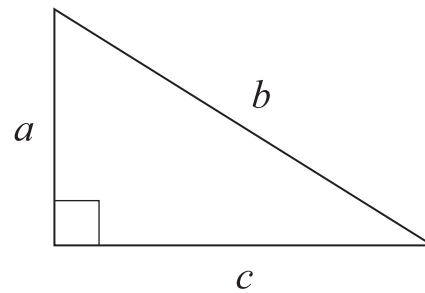
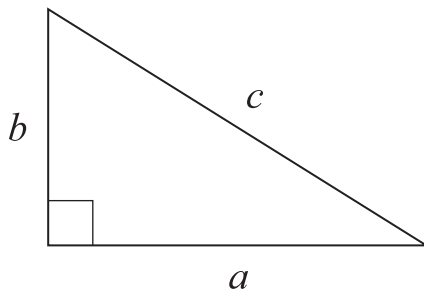

For the **other** triangle, write an equation linking a , b and c



1 mark

(b) In which triangle below does $a^2 + b^2 = c^2$?

Tick (✓) the correct triangle.

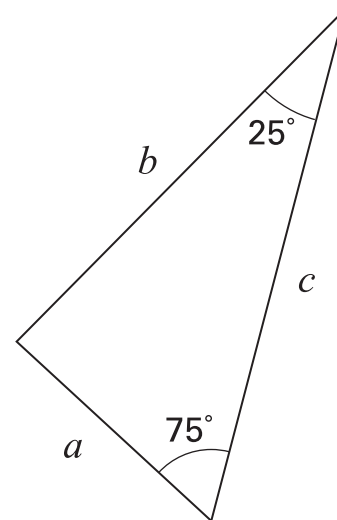
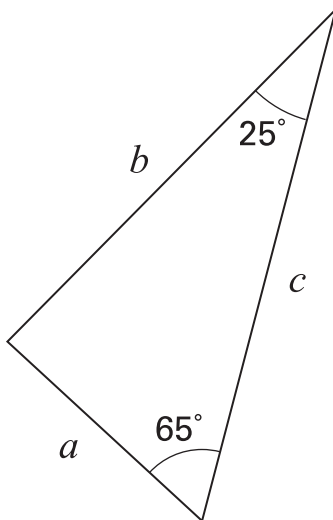

Not drawn accurately

For the **other** triangle, explain why $a^2 + b^2$ does not equal c^2



1 mark

14. Meg and Ravi buy sweet pea seeds and grow them in identical conditions.

Meg's results:

Number of packets	Number of seeds in each packet	Number of seeds that germinate from each packet
5	20	18, 17, 17, 18, 19

Ravi's results:

Number of packets	Number of seeds in each packet	Total number of seeds that germinate
10	20	170

- (a) Using Meg's results and Ravi's results, calculate two different estimates of the **probability** that a sweet pea seed will germinate.



Using Meg's results:

1 mark

Using Ravi's results:

1 mark

- (b) Whose results are likely to give the better estimate of the probability?



Meg's Ravi's

Explain why.



1 mark

15. A three-digit number is **multiplied** by a two-digit number.
How many digits could the answer have?

Write the minimum number and the maximum number of digits that the answer could have.

You **must** show your working.



minimum number of digits

maximum number of digits

.....

.....

2 marks

16. Solve these simultaneous equations using an algebraic method.

$$4x + 3y = 21$$

$$2x + y = 8$$

You **must** show your working.



$$x = \dots\dots\dots \quad y = \dots\dots\dots$$

.....

.....

.....

3 marks



17. In the diagram, lines AB and AC are straight lines.

Using compasses and a straight edge, construct the angle bisector of angle BAC.

You **must** leave in your construction lines.

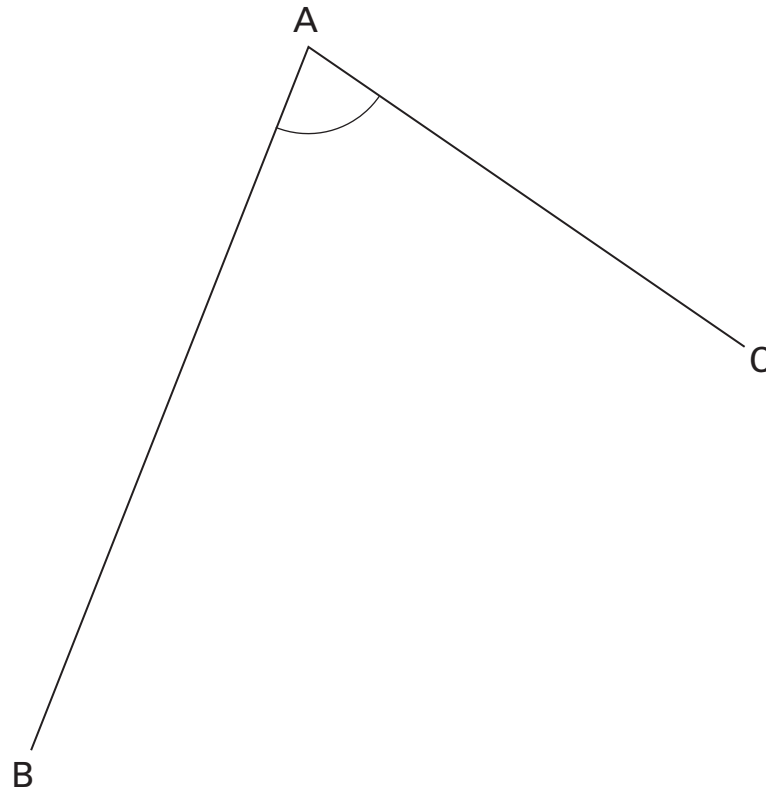

.....

.....
2 marks

18. The diagram shows two shapes that are mathematically similar.

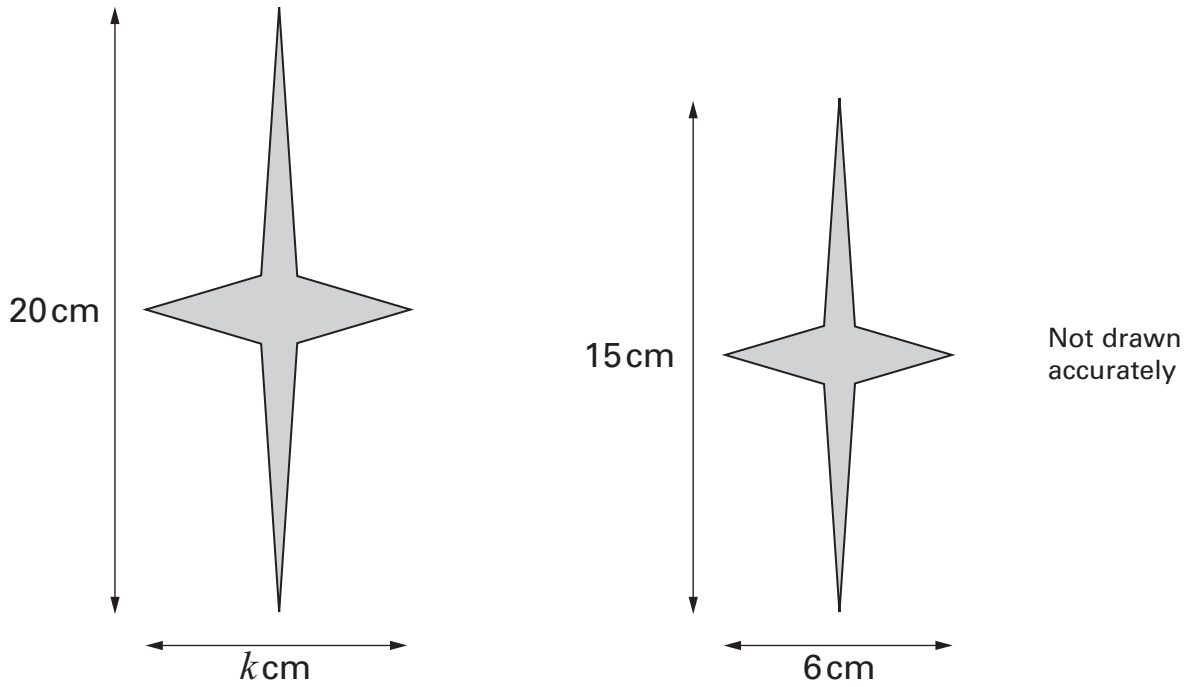

(a) What is the value of k ?



.....

.....
1 mark

(b) I want to draw another shape that is mathematically similar to the ones in the diagram, but of a different size.

Give the length and width of a shape I could draw.



length cm

width cm

.....
1 mark



19. The diagram shows the straight line with equation $y = 4(x - 2)$

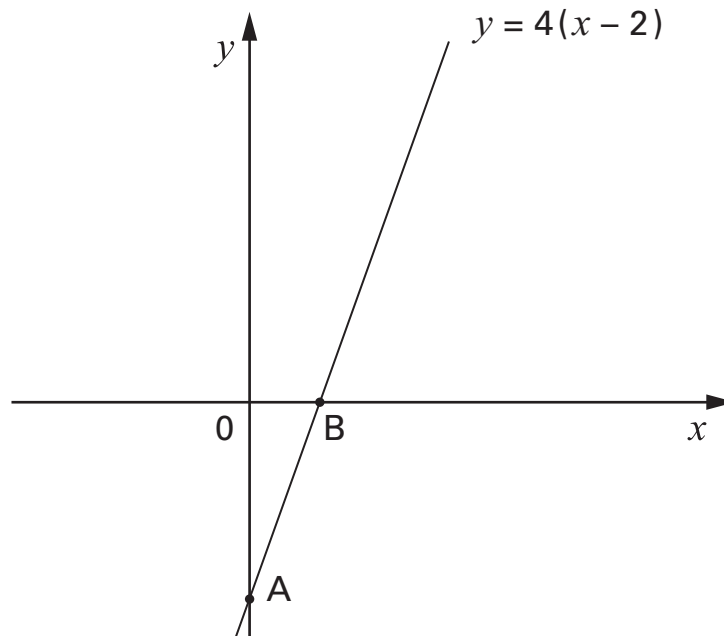

Not drawn accurately

- (a) Work out the coordinates of the points marked A and B.



A is (..... ,)

.....
1 mark

B is (..... ,)

.....
1 mark

- (b) A different straight line goes through the points $(0, 0)$ and $(3, 6)$

Write the equation of this line.



.....
1 mark

20. Two groups of pupils collected a sample of acorns from the same oak tree.

The box plots summarise the two sets of results.

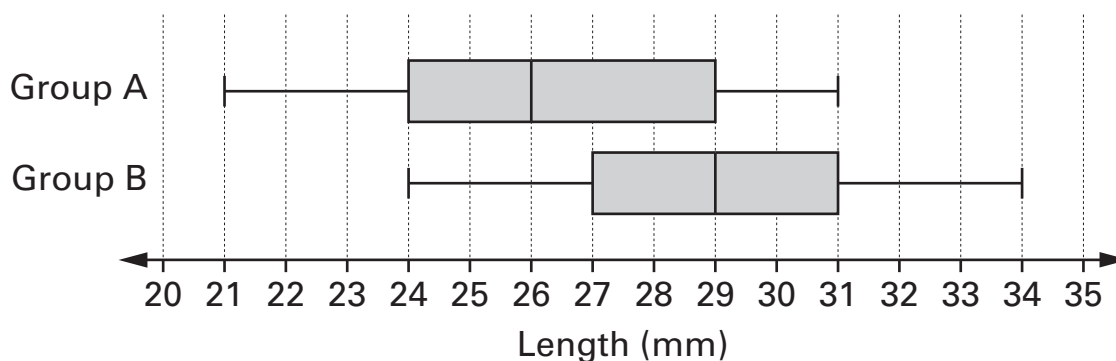

- (a) Explain how the box plots show the **median** of group B is **3mm more** than the median of group A.



1 mark

- (b) Which group has the bigger **inter-quartile range**?



A

B

Explain your answer.



1 mark

- (c) The results from the two groups of pupils are very different.
Give a reason why the results might have been different.



1 mark

21. (a) Show that $(4 \times 10^8) \times (8 \times 10^4) = 3.2 \times 10^{13}$



.....
1 mark

(b) What is $(4 \times 10^8) \div (8 \times 10^4)$?

Write your answer in standard form.



.....
.....
2 marks

22. Here is information about a data set.

There are 100 values in the set.

The median is 90

The mean is 95

I **increase** the **highest value** in the data set **by 200**

Now what are the median and the mean of the data set?



median =

mean =

.....
.....
2 marks



23. The diagram shows a sketch of a **rhombus**, side length **8 cm**.
The length of one diagonal is **10 cm**.

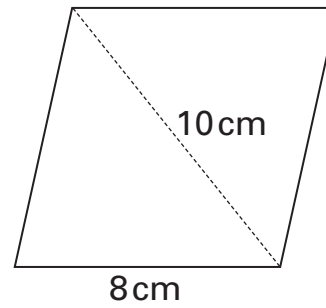

Not drawn accurately

Use compasses and a straight edge to make an accurate drawing of the rhombus.

You can use the 8 cm and 10 cm lines to set your compasses.

You **must** leave in your construction lines.

8 cm

10 cm



.....

.....
2 marks

24. In this question, a and b are numbers where $a = b + 2$
The **sum** of a and b is **equal to** the **product** of a and b

Show that a and b are **not integers**.



.
.
.
3 marks



25. To change temperatures measured in °C to °F you can use an exact formula or an approximate formula.

Exact formula

$$F = \frac{9C}{5} + 32$$

Approximate formula

$$F = 2C + 30$$

F is the temperature in °F

C is the temperature in °C

At what temperature in °C do these formulae give an **equal** value for F?

You **must** show an algebraic method.



..... °C

.....
.....
2 marks

END OF TEST



