

Ma

KEY STAGE

2

LEVELS

3-5

Mathematics test

Test A

Calculator not allowed

First name _____

Last name _____

School _____

DfE no. _____

2011

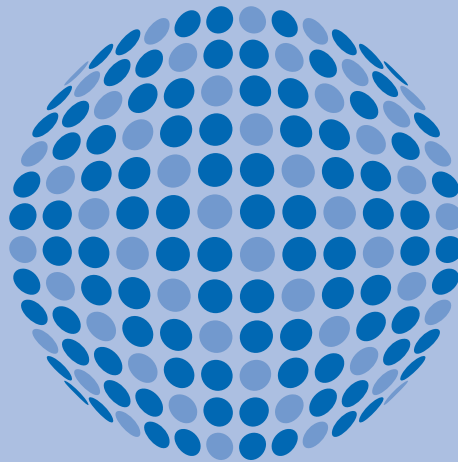

For marker's use only

Page	Marks
5	
7	
9	
11	
13	
15	
17	
19	
21	
23	
TOTAL	

These three children appear in some of the questions in this test.

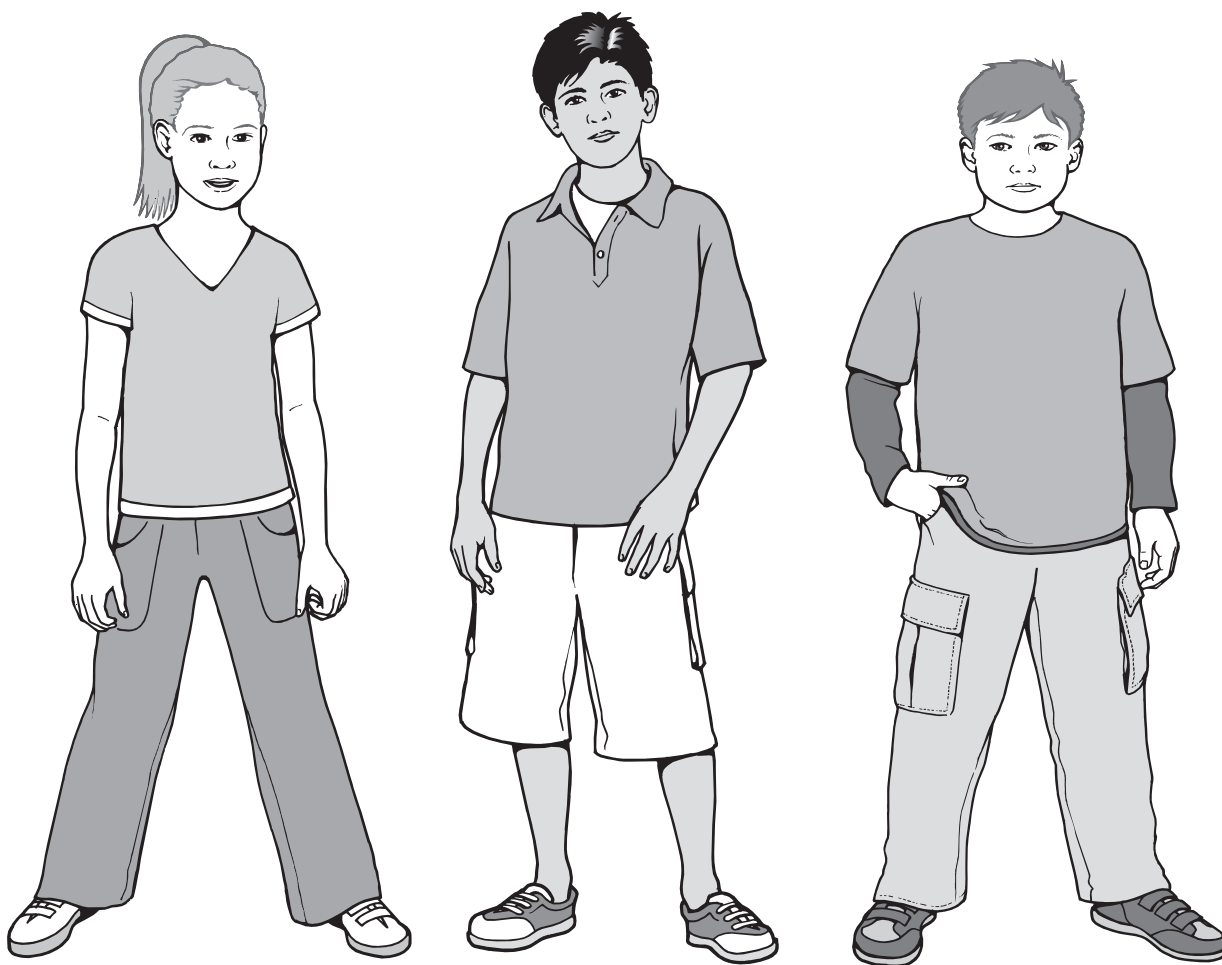

Holly

Dev

Joe

Instructions

You **may not** use a calculator to answer any questions in this test.

Work as quickly and as carefully as you can.

You have **45 minutes** for this test.

If you cannot do one of the questions, **go on to the next one**.

You can come back to it later, if you have time.

If you finish before the end, **go back and check your work**.

Follow the instructions for each question carefully.



This shows where you need to put the answer.

If you need to do working out, you can use any space on a page.

Some questions have an answer box like this:

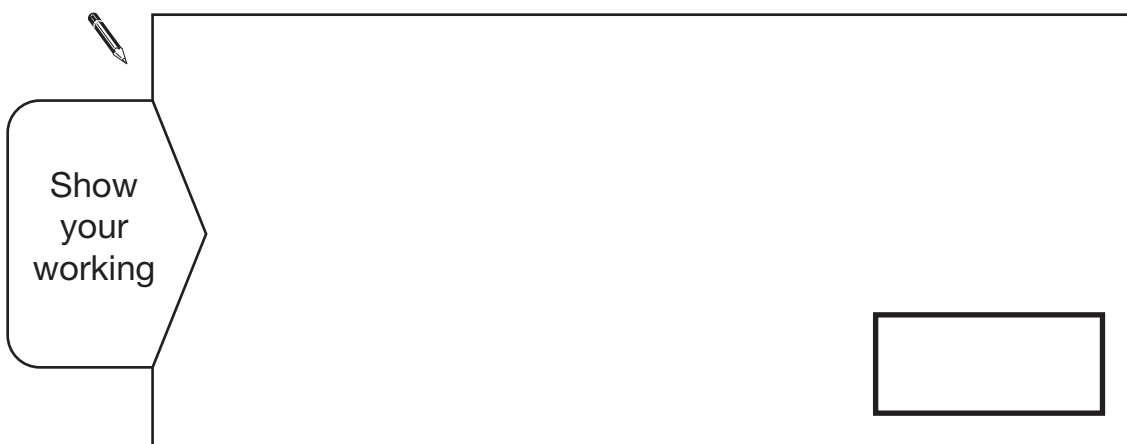

For these questions you may get a mark for showing your working.

1

Holly made a number using these digit cards.

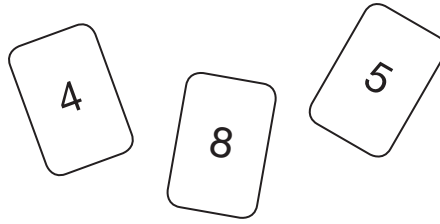

The **hundreds** digit is greater than 4

Holly's number is **odd**.

What number did Holly make?

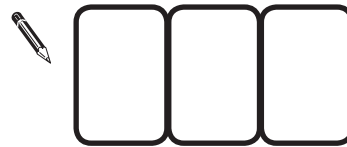

1
1 mark

2

Write one number from each circle to make this calculation correct.

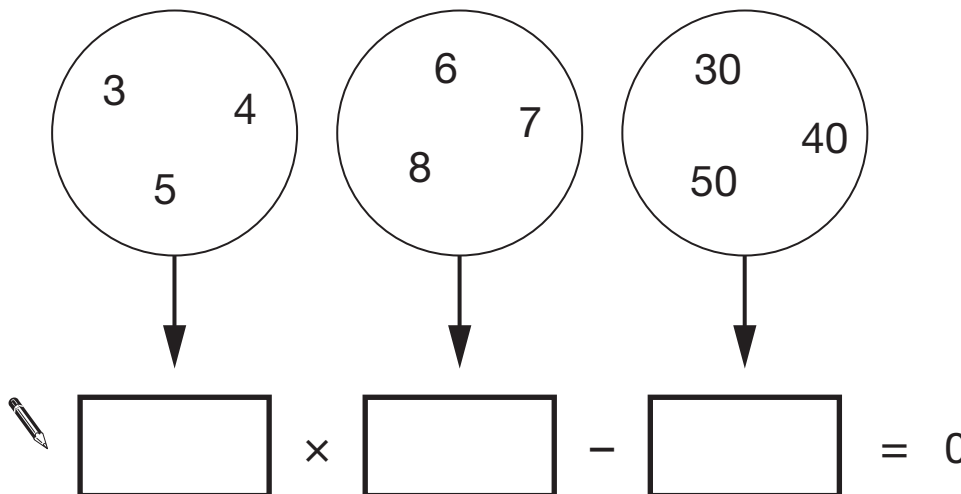

$\square \times \square - \square = 0$

2
1 mark

3

Class 6 collect litter from a park.

This chart shows some of the litter they have collected so far.

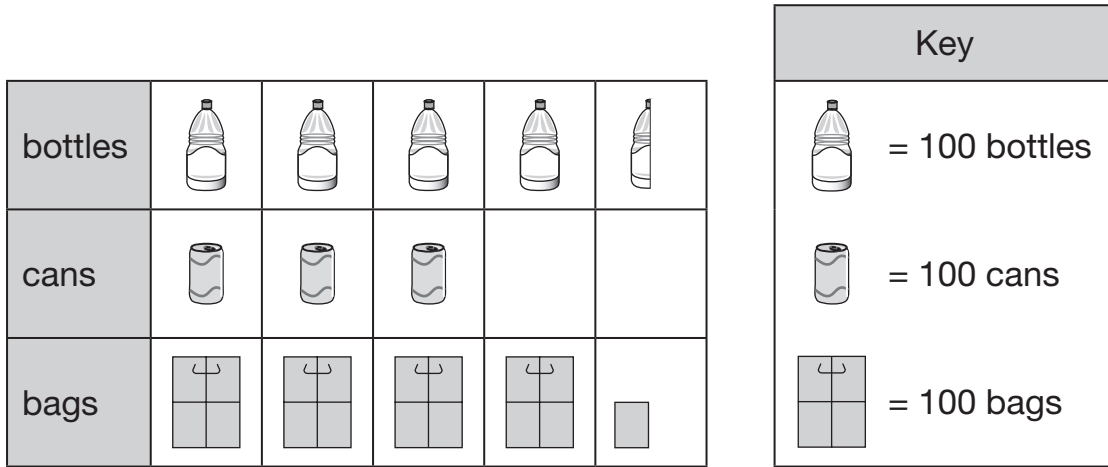

How many bottles have Class 6 collected?



3a

1 mark

How many **more** bags than cans have they collected?



3b

1 mark

4

Dev has five coins.

He has £1.60 altogether.

Write what the five coins could be.



4

1 mark

5

Here are six shapes on a square grid.

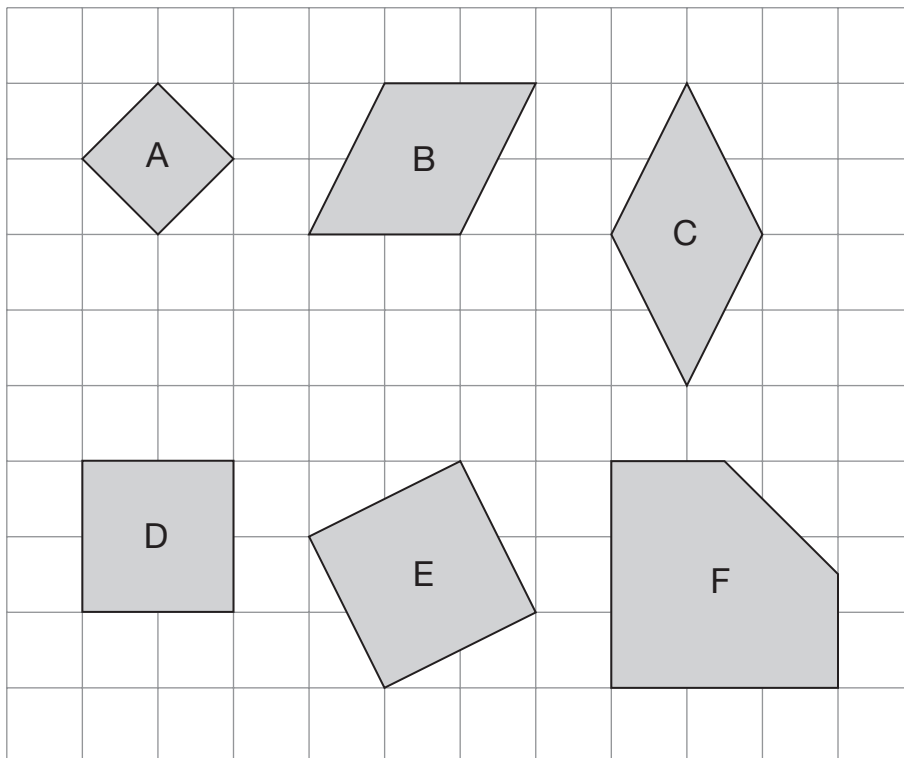

Write the letters of **all** the shapes that are squares.



5

1 mark

6

Joe has a box of 72 chocolates.



He gives 18 of the chocolates to his friends.

How many chocolates are left in the box?



6a

1 mark

Holly has a box of mints.



She has 10 friends.

She gives them 5 mints each.

She has 13 mints left.

How many mints were in the box at the start?



6b

1 mark



Holly takes **half an hour** to walk from home to school.

She arrives at school at 8:25 am.

At what time did she leave home?



am

7a

1 mark



Dev leaves school at half past three.

He arrives home at ten past four.

How many minutes did it take him to get home?



minutes

7b

1 mark

8

The four sums below can be completed using only the numbers 1 to 8

Use each number **once** to complete the sums.

One sum has been done for you.

1 2 3 4 ~~5~~ ~~6~~ 7 8

$$1 + \boxed{5} + \boxed{6} = 12$$

$$\img alt="pencil icon" data-bbox="265 366 295 395"/> 2 + \boxed{} + \boxed{} = 12$$

$$3 + \boxed{} + \boxed{} = 12$$

$$6 + \boxed{} + \boxed{} = 12$$

8i

8ii

2 marks

9

Here is part of a number sequence.

The numbers in the sequence increase by 25 each time.

50 75 100 125 ...

Circle **all** of the numbers below that will appear in the sequence.



255 650 735 900 995

9

1 mark

10

Shade **two** squares and **one** triangle to make this design symmetrical about the mirror line.

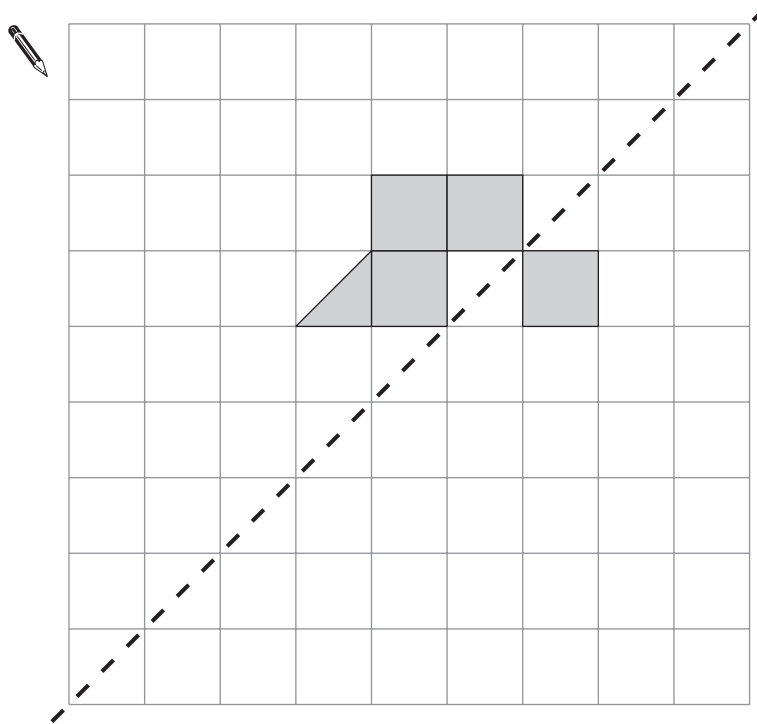

mirror line

10

1 mark



9×3 8×4

$9 - 3$ $8 - 4$

$9 + 3$ $8 + 4$

$9 \div 3$ $8 \div 4$

11i

11ii

2 marks

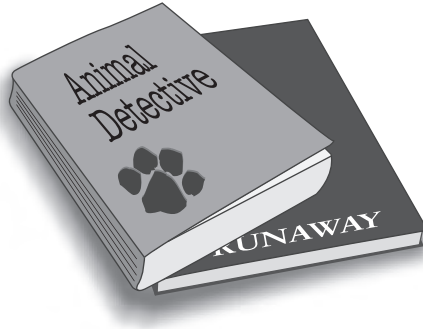

Dev and Joe each buy a book.

Dev pays with a £5 note and gets £1.05 change.

Joe's book costs £7

How much **more** does Joe's book cost than Dev's book?



Show
your
working

£

12i

12ii

2 marks

13

Here are some shapes on a 1 cm square grid.

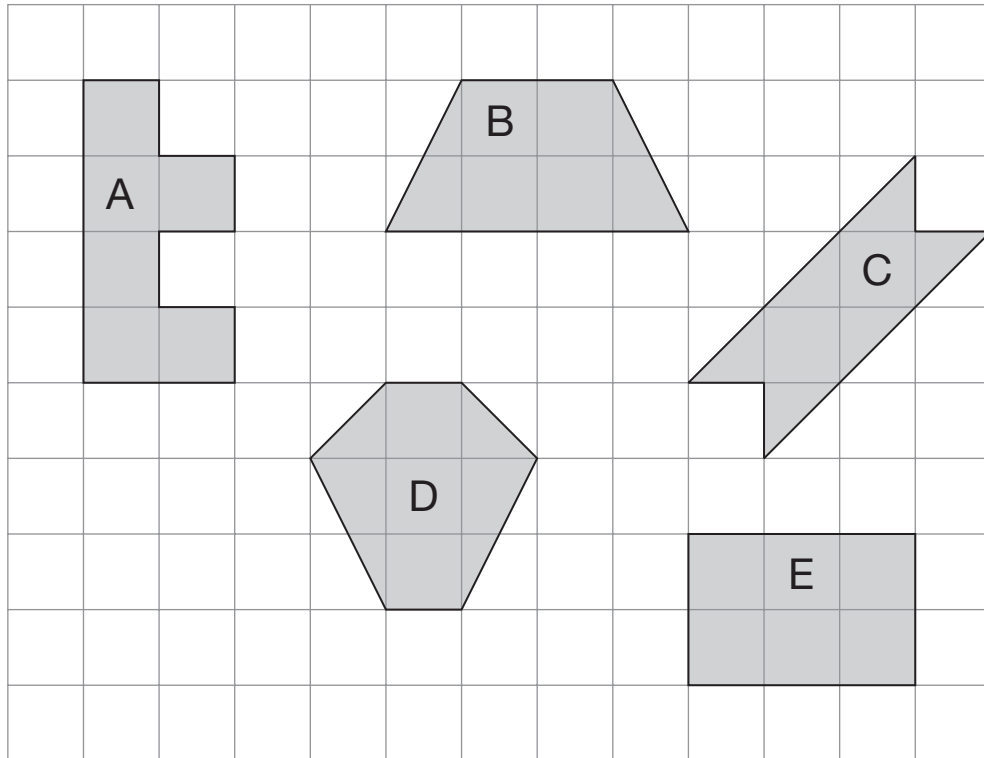

What is the **perimeter** of shape A?



13a

1 mark

Write the letter of the shape that has the **smallest area**.



13b

1 mark

14

Joe places some apples on a weighing scale.

The pointer shows the mass of the apples.

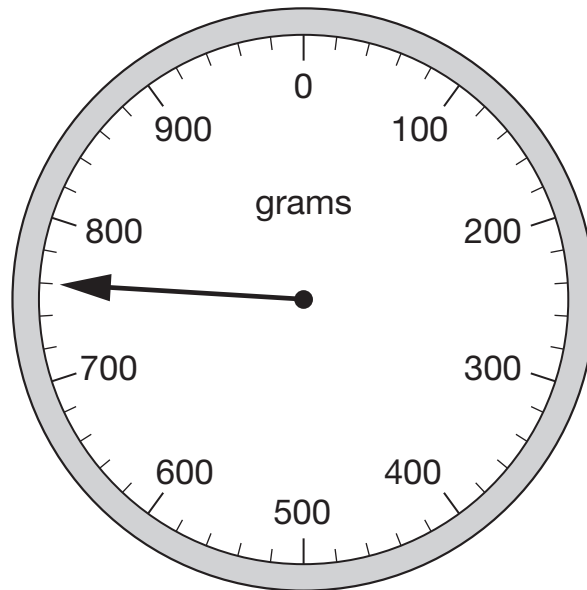

He takes away one apple.

The mass goes down by 120 grams.

Draw the pointer in its new position on the scale below.

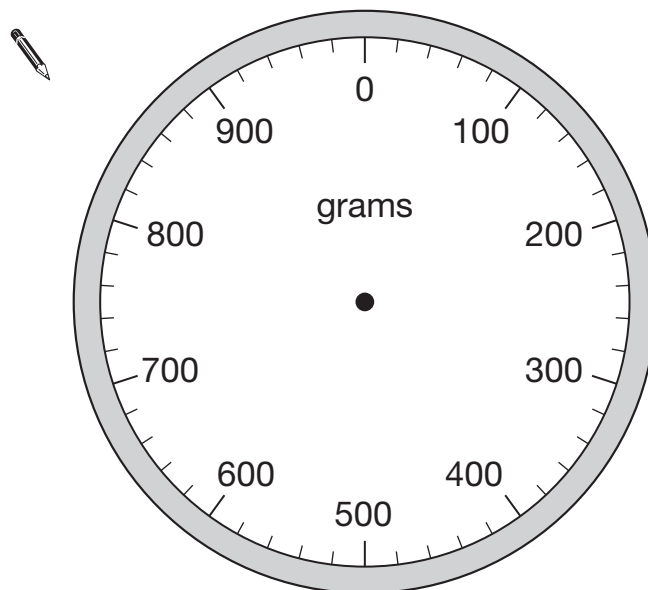

14

1 mark

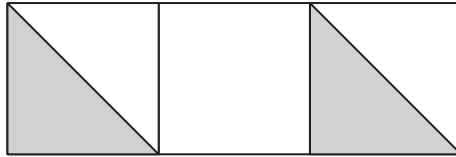

Holly says,

'One-third of this shape is shaded'.

Is Holly correct?
Circle **Yes** or **No**.

 Yes / No

Explain how you know.



15

1 mark

This chart shows the favourite snacks of some boys and girls.

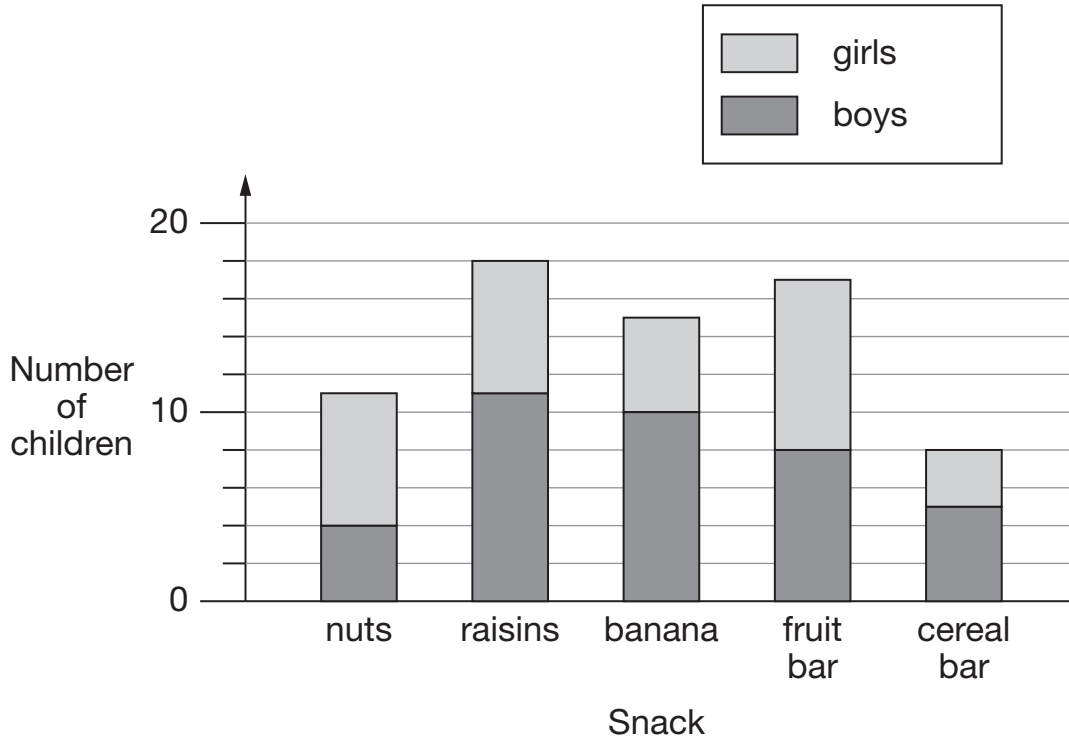

How many snacks were chosen by more girls than boys?



16a

1 mark

How many more boys than girls chose raisins?



16b

1 mark

Which snack was chosen by twice as many boys as girls?



16c

1 mark

17

Calculate $3.81 + 18.3$



17

1 mark

18

Dev has three discs.

Each disc has a 7 on one side and an 8 on the other side.



He spins all the discs and adds the three scores together.

How many **different totals** can he get using the three discs?



18

1 mark

19

500 children started a 20 kilometre sponsored cycle ride.

This graph shows how far they cycled.

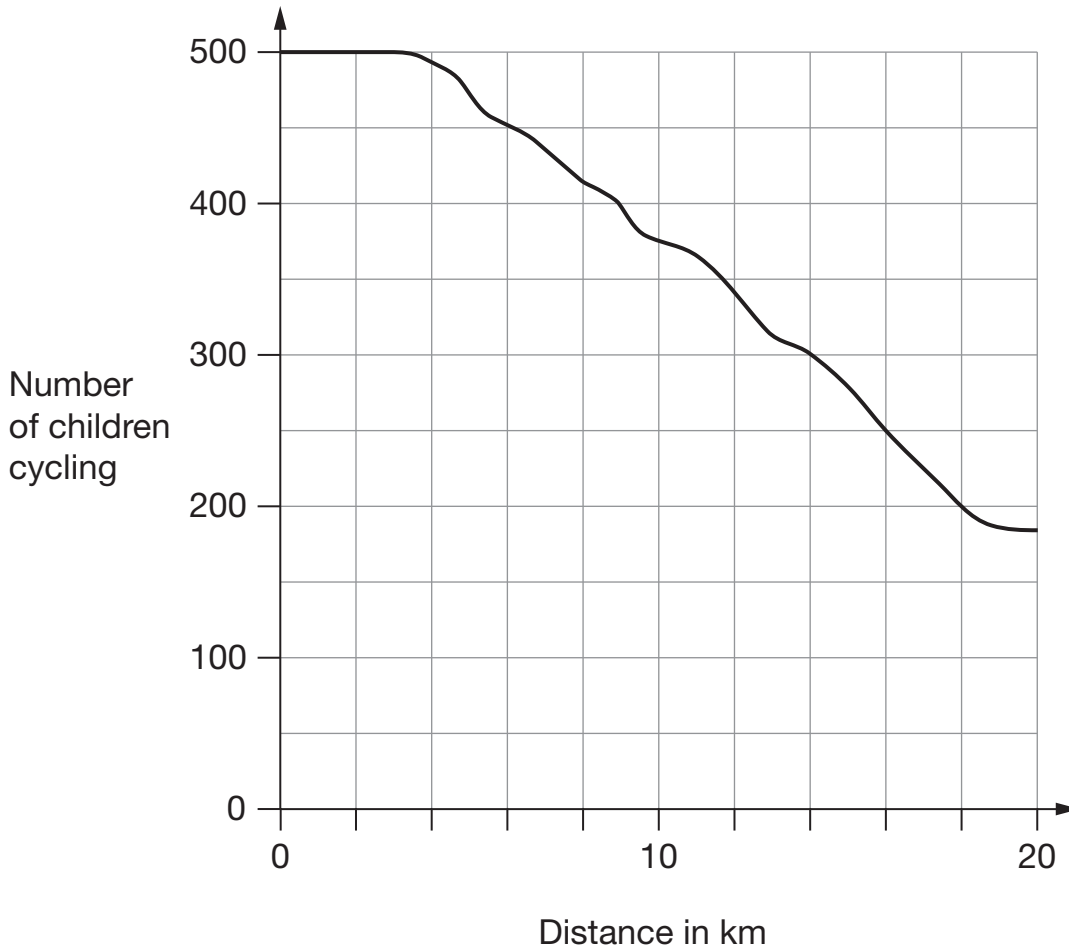

At what distance were exactly half of the children still cycling?



19a

1 mark

Estimate how many children completed the 20 kilometre cycle ride.



19b

1 mark

20

Here are five number cards.

0.47

10

100

1000

4.07

Use **four** of the cards to complete these calculations.

 $47 \div \boxed{} = \boxed{}$

$\boxed{} \times \boxed{} = 40.7$

20

1 mark

21

Calculate $544 \div 32$



Show
your
working

21i

21ii

2 marks

22

This cube has shapes drawn on three of its faces.

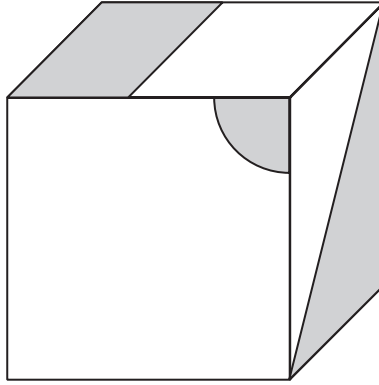

The cube is turned to look like this.

Draw and shade the missing shapes.

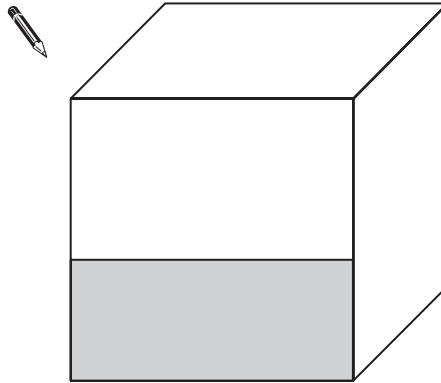

22a

1 mark

22b

1 mark

24

Here is a sketch of a quadrilateral.

It is not drawn to scale.

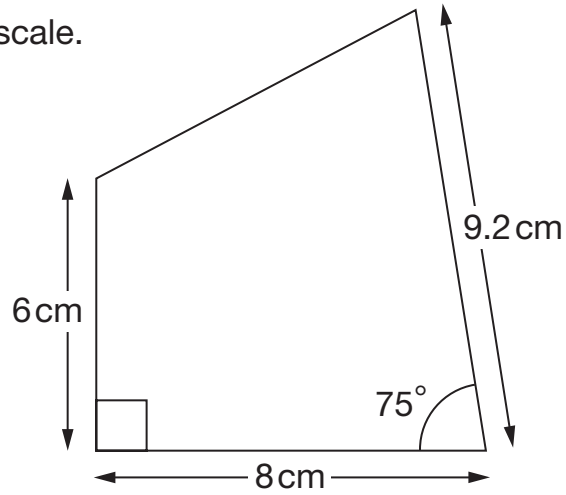

Draw the full-size quadrilateral **accurately** below.

Use a protractor (angle measurer) and a ruler.

Two of the lines have been drawn for you.

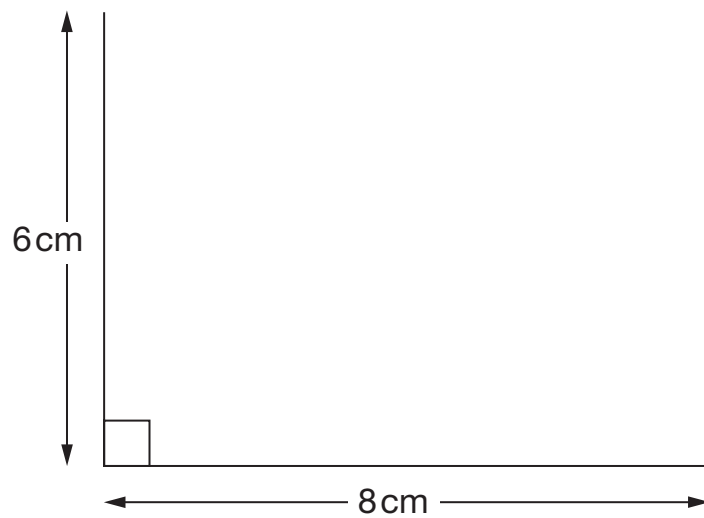

24i

24ii

2 marks

25

Joe has two strips of card.

Each strip is 36 centimetres long.

One strip is divided into three equal parts.

The other strip is divided into four equal parts.

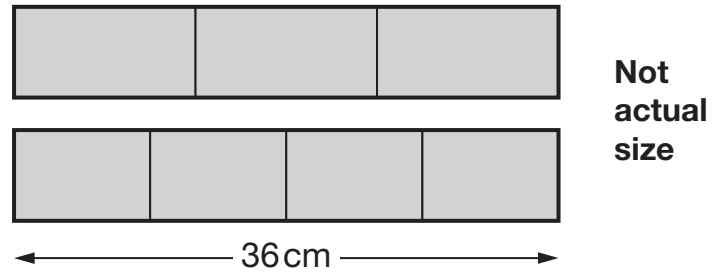

Joe uses the two strips to make this shape.

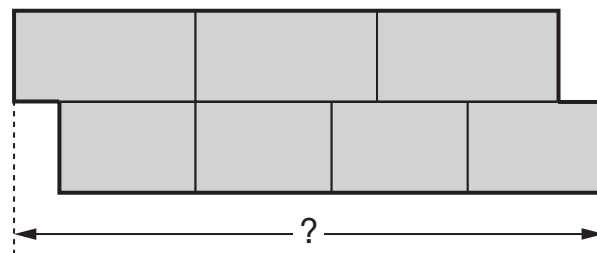

What is the total length of Joe's shape?

Show your working

cm

25i

25ii

2 marks

