

LEVEL 6
TESTS

ANSWER
BOOKLET

MATHEMATICS TEST

LEVEL 6 TESTS

Ma

Paper 1 – calculator not allowed

First name			
Middle name			
Last name			
Date of birth	Day	Month	Year
Please circle one	Boy	Girl	
Year group			
School			

YOU MAY NEED

- Pens, pencils and a rubber.
- A ruler.
- A pair of compasses.
- A protractor or angle measurer.
- Tracing paper.
- A mirror.

REMEMBER

- You have 30 minutes to complete this test paper.
- You may not use a calculator for any question in this test paper.
- Try to answer all the questions.
- Write all your answers and working on the test paper – do not use any rough paper. Marks may be awarded for working.
- Check your work carefully.
- Ask your teacher if you are not sure what to do.

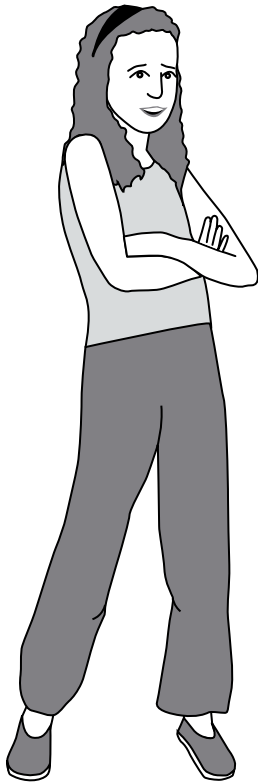

Lisa

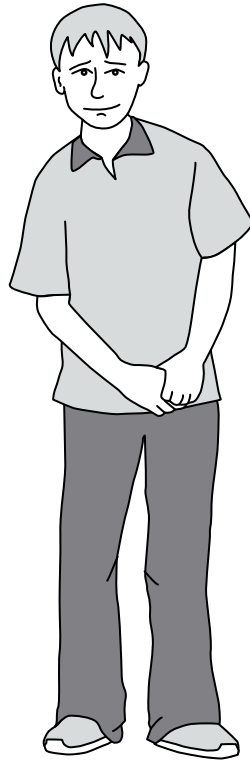

Nik

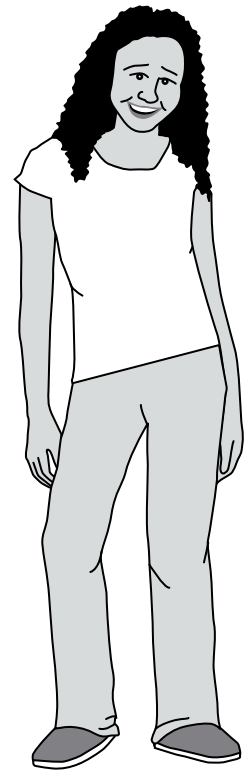

Kemi

You might need to use this formula.

Trapezium

$$\text{Area} = \frac{1}{2}(a + b)h$$

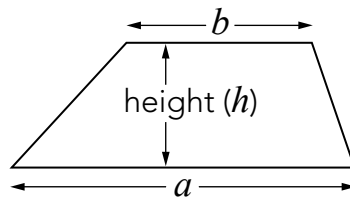

Instructions

You **may not** use a calculator to answer any questions in this test paper.

- Work as quickly and as carefully as you can.
 - You have 30 minutes for this test paper.
 - If you cannot do one of the questions, **go on to the next one**. You can come back to it later, if you have time.
 - If you finish before the end, **go back and check your work**.
-

Follow the instructions for each question carefully.



This shows where you need to put the answer.

If you need to do working out, you can use any space on a page.

Some questions have an answer box like this:



The diagram illustrates a question box layout. It consists of a large outer rectangle. On the left side, there is a smaller rounded rectangle with a pencil icon above it and the text "Show your working". To the right of this rounded rectangle is a large empty space. In the bottom right corner of the large outer rectangle, there is a smaller empty rectangular box.

For these questions you may get a mark for showing your working.

1

Here is information about pupils in a class.

- The total number of pupils is 30
- 26 of the pupils do not wear glasses.
- A quarter of the pupils who do wear glasses are boys.
- There are 2 more boys than girls.

Use the information to fill in the missing numbers in the table below.



	Number who do wear glasses	Number who do not wear glasses	Total
Number of boys			
Number of girls			
Total			30

(2 marks)

2

The shaded shape is a **square**.

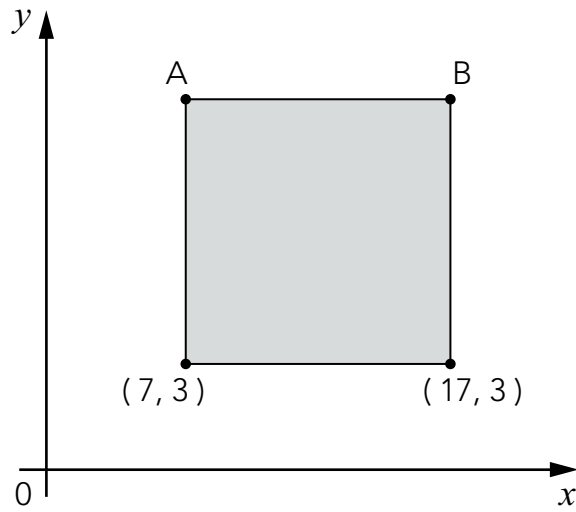

Not drawn accurately

What are the coordinates of A and B?



A (_____ , _____) B (_____ , _____) (2 marks)

3

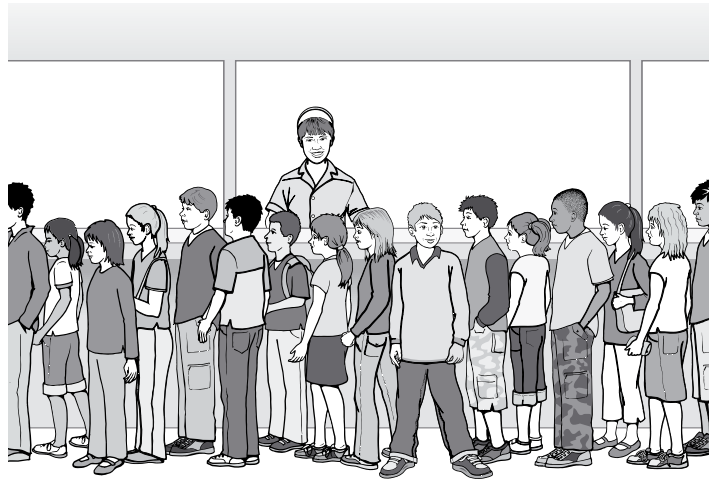

There are 25 children in the lunch queue, including Nik.

Nik says,

'There are twice as many children in front of me as there are behind me.'

How many children are **in front** of Nik?



Show
your
working

children

(2 marks)

4

These patterns are drawn on square grids.

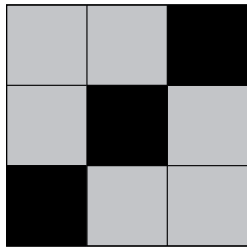

Pattern A

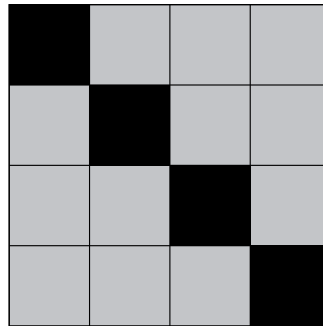

Pattern B

In pattern A, the **ratio** of black squares to grey squares is **1 : 2**

What is the ratio of black squares to grey squares in pattern B?



1 :

(1 mark)

Now look at this new pattern.

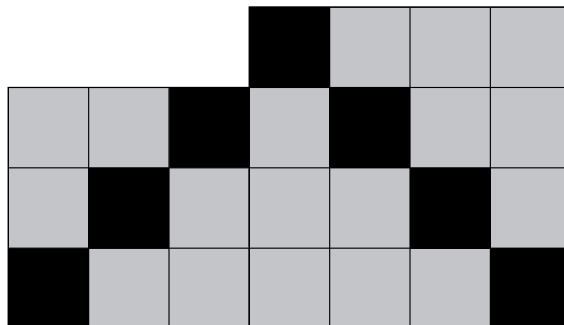

What **percentage** of the new pattern is **black**?



	%
--	---

(1 mark)

5

Here are three equations.

$$a + b + c = 30$$

$$a + b = 24$$

$$b + c = 14$$

What are the values of a , b and c ?



$a =$ $b =$ $c =$ (2 marks)

6

The diagrams show a rectangle divided into different parts.

On each, **shade the area** represented by the expression.

The first one is done for you.

ac

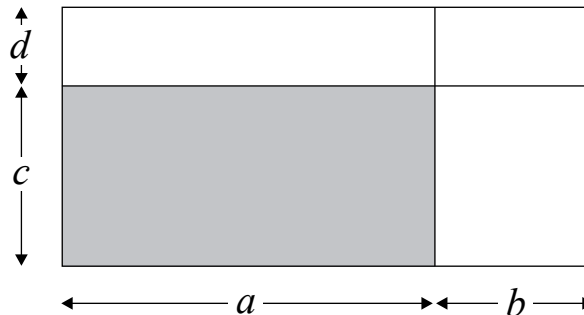

$ad + bd$

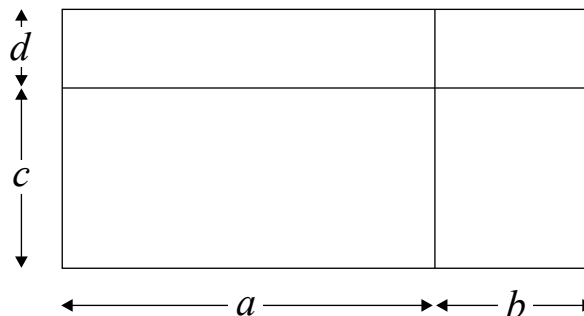

(1 mark)



$b(c + d)$

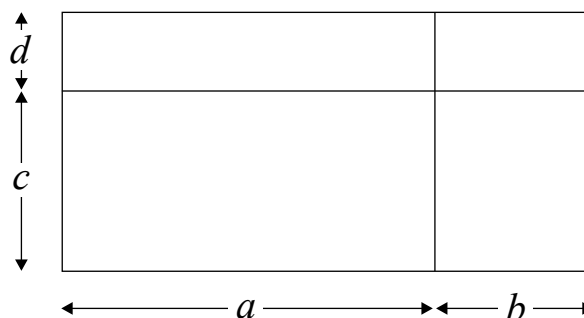

(1 mark)

7

Here are three scatter diagrams, labelled A, B and C.

Scatter diagram A

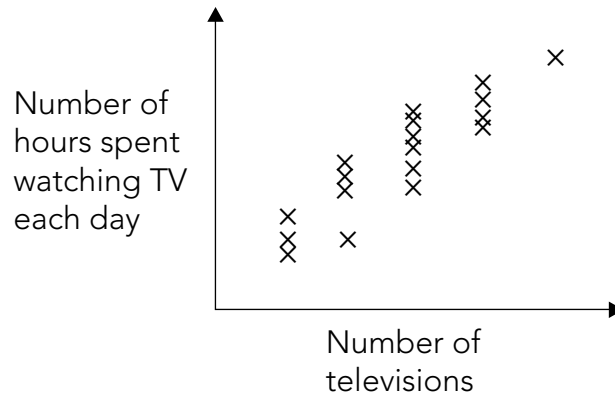

Scatter diagram B

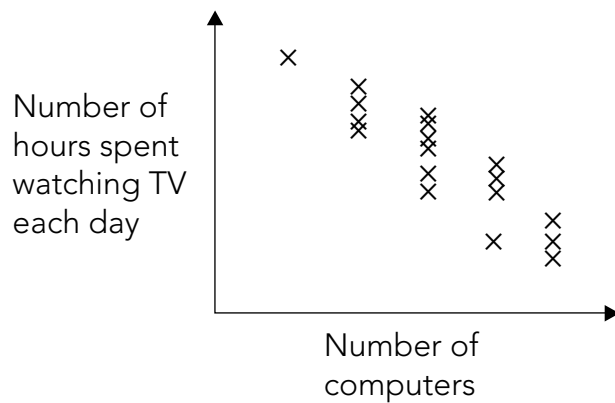

Scatter diagram C

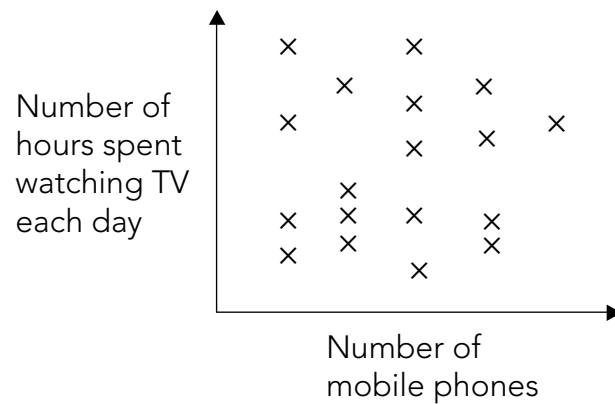

The questions are on the next page.

Kemi writes:

Scatter diagram **A** shows that the more televisions a person has in
their home the more hours they spend watching television.

Now complete the sentences below.



Scatter diagram **B** shows that _____

_____ (1 mark)



Scatter diagram **C** shows that _____

_____ (1 mark)

8

The diagram shows a pentagon.

Not drawn accurately

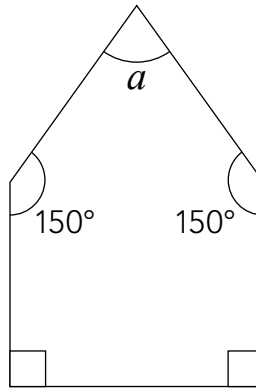

Each side of the pentagon is the **same length**.

Is the shape a **regular** pentagon?

Circle Yes or No.



Yes / No

Explain your answer.



A large, cloud-shaped area provided for the student to write their explanation.

(1 mark)

Work out the size of angle a



Show your working

A large rectangular area for showing the student's working. At the bottom right, there is a box for the answer: $a =$ followed by a rectangular box with a degree symbol $^\circ$ inside.

(2 marks)

9

The diagram shows four straight lines, A, B, C and D.

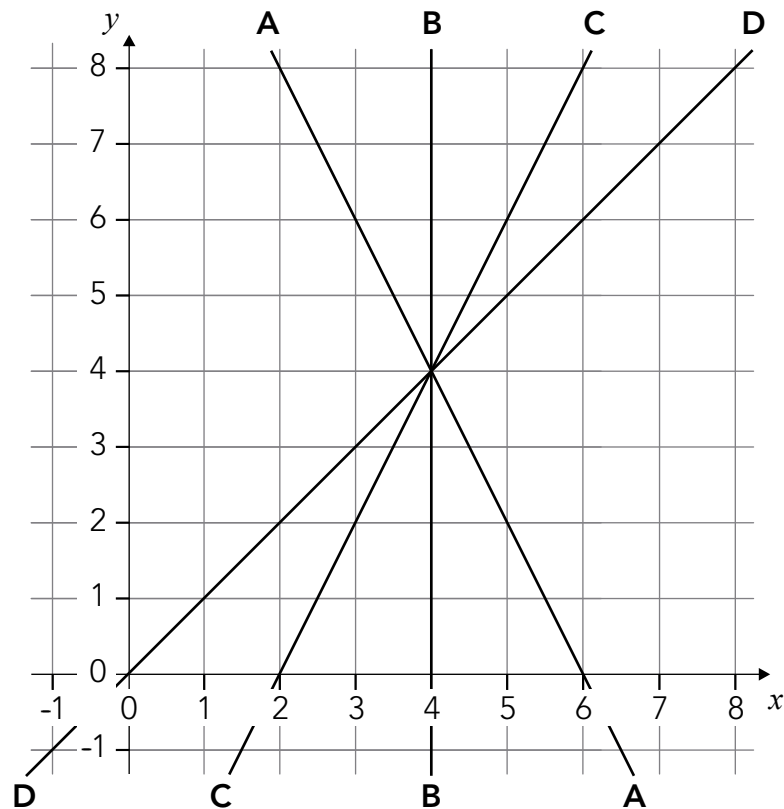

Which line has the equation $y = x$?

Circle A, B, C or D.



A / B / C / D

Which line has the equation $x = 4$?

Circle A, B, C or D.



A / B / C / D (1 mark)

Draw a horizontal straight line through the point (4, 4) and **write its equation.**



(1 mark)

10

Here is a triangle.

Two of its sides are 4cm and **two** of its angles are 45°

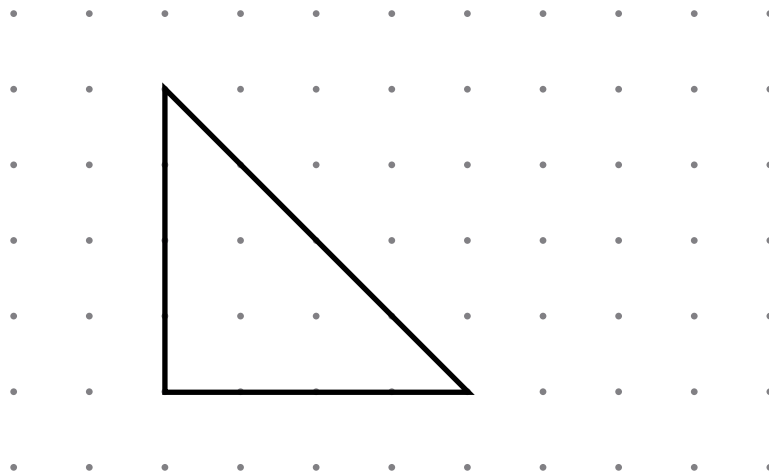

Join dots to make a different triangle.

Make **only one** of its sides 4cm and **only one** of its angles 45°



(1 mark)

11

Write the missing numbers.



$$\frac{\boxed{}}{160} = 0.1$$

(1 mark)



$$\frac{160}{\boxed{}} = 0.2$$

(1 mark)

12

Here are four numbers.

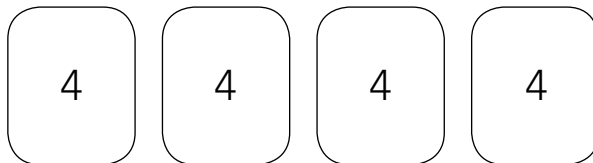
Their **mean** is 4 and their **range** is 0Write four numbers that have a **mean** of 4 and a **range** of 4

□ □ □ □

(1 mark)

13

A dragon lived in a cave.

The dragon **doubled** in size every day.

After **20 days** the dragon filled the cave.

After how many days did the dragon **half-fill** the cave?



After days

(1 mark)

14

I am thinking of a number that is not zero.

I **multiply** my number by **-5**

Tick (✓) the statement below that is true.



The answer must be positive.

The answer must be negative.

The answer could be positive or negative.

Explain how you know.



Large cloud-shaped area for writing an explanation.

(1 mark)

END OF TEST

DO NOT WRITE ON THIS PAGE

DO NOT WRITE ON THIS PAGE

DO NOT WRITE ON THIS PAGE

QCDA/11/5452

Optional level 6 tests | Mathematics paper 1