

**JUNIOR LYCEUM ANNUAL EXAMINATIONS 2007**

Educational Assessment Unit - Education Division

**FORM 5**

**TEXTILES STUDIES**

**TIME: 1h 45min**

Name: \_\_\_\_\_

Class: \_\_\_\_\_

1. Garments can be given shape and movement in different ways.

a. Identify the ways of controlling fullness and giving shape, found in these diagrams.

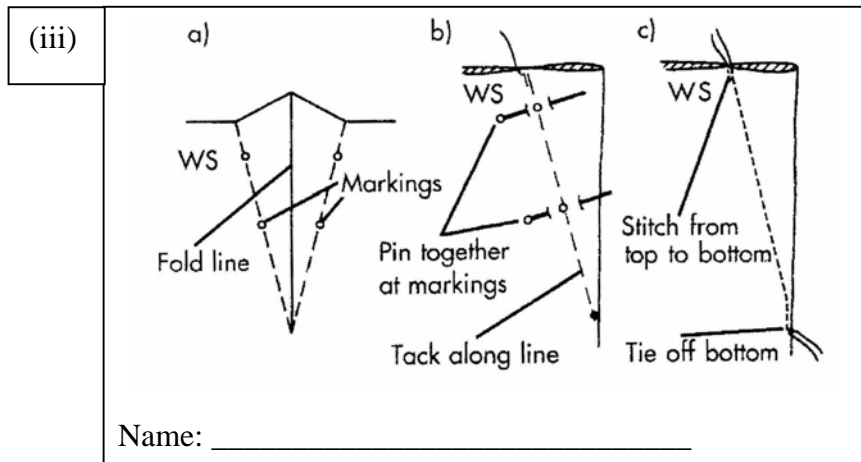
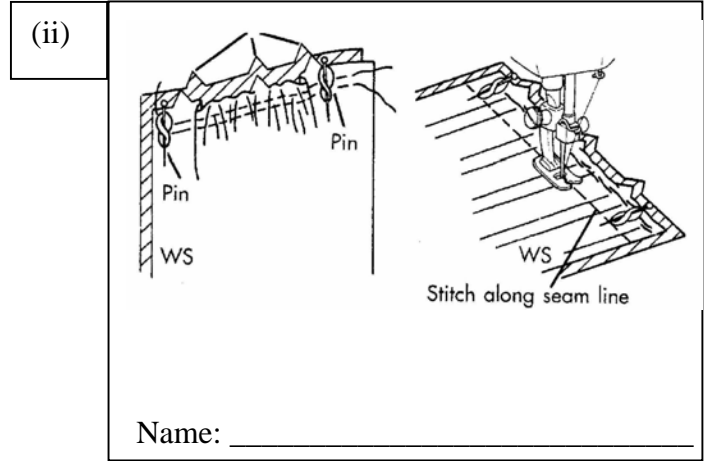
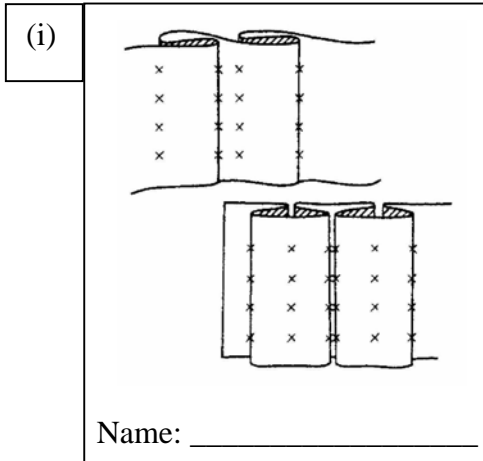

(3 marks)

b. Design **two** garments making use of **two** of the methods in question 1a. Draw front and back views.

	<b>A</b>		<b>B</b>	
<b>Front</b>		<b>Back</b>	<b>Front</b>	<b>Back</b>

(2, 2 marks)

c. Suggest **one** occasion when these garments can be worn.

Garment A: \_\_\_\_\_

Garment B: \_\_\_\_\_ (1, 1 mark)

d. (i) Indicate for which figure type you would suggest each outfit.

Figure Type **Garment A** \_\_\_\_\_

**Garment B** \_\_\_\_\_ (1, 1 mark)

(ii) Give a reason for each choice

**Reason A** \_\_\_\_\_  
\_\_\_\_\_ (2 marks)

**Reason B** \_\_\_\_\_  
\_\_\_\_\_ (2 marks)

e. From the methods of controlling fullness found in question 1a, identify a method suitable for children's garments, and a method which is not suitable for children's garments.

(i) Method suitable for children's garments. \_\_\_\_\_

(ii) Method not suitable for children's garments. \_\_\_\_\_  
(1, 1 mark)

2a. Sketch a pair of fashionable trousers suitable for a teenager.  
Include a pocket / pockets and a waistband or facing.  
Draw front and back views.

**Trousers**

**Front**



**Back**



(1, 1 mark)

b. List **three** measurements needed to make these trousers.

(i) \_\_\_\_\_ (ii) \_\_\_\_\_

(iii) \_\_\_\_\_ (3 marks)

c. Calculate the amount of fabric needed to make these trousers.

Give the width of the fabric.

**Amount of fabric** \_\_\_\_\_ **Width** \_\_\_\_\_ (1/2, 1/2 mark)

d. Draw the pattern pieces which make up the pattern. Label each pattern piece.

(4 marks)

e. Draw the pattern layout of the trousers on 150cm wide plain fabric. Mark the fold and selvedge.

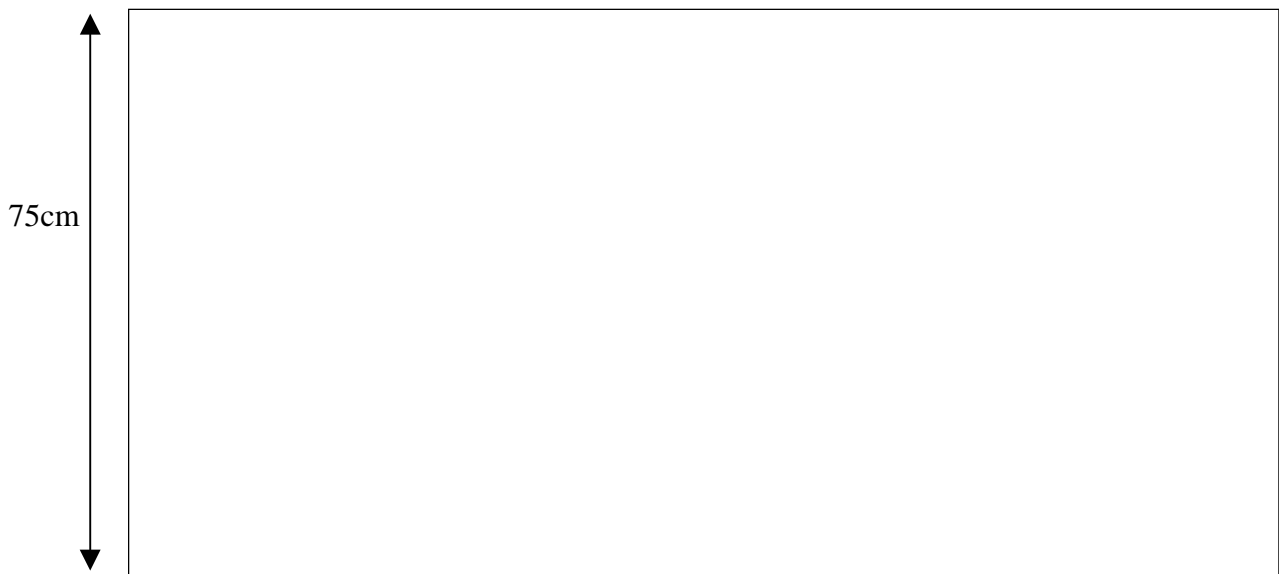

(4, 2 marks)

f. Complete the flowchart below, to explain the making up of this pair of trousers.

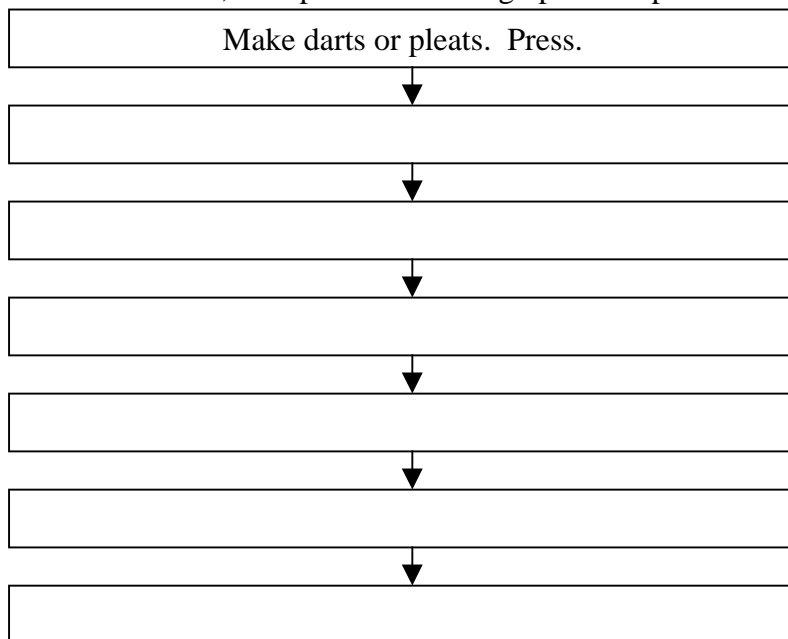

(6 marks)

3a. Modern irons have three temperature settings indicated by one, two or three dots. Complete this diagram by filling in the necessary details.

	160°C	warm	<hr/> <hr/>
	_____°C	_____	acrylic nylon

(5 marks)

b. When ironing and pressing different items, care should be taken to determine (*find out*) what fabric the item is made from.

Explain, by giving **two** reasons for this.

(i) \_\_\_\_\_

(ii) \_\_\_\_\_

(2 marks)

c.

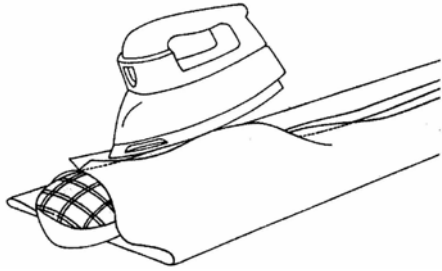

The diagram shows a seam roll.

Give the use of a seam roll.

Use \_\_\_\_\_

(1 mark)

d. As a consumer, what points should you consider before purchasing a new steam iron? List **three** points.

(i) \_\_\_\_\_

(ii) \_\_\_\_\_

(iii) \_\_\_\_\_

(3 marks)

4.

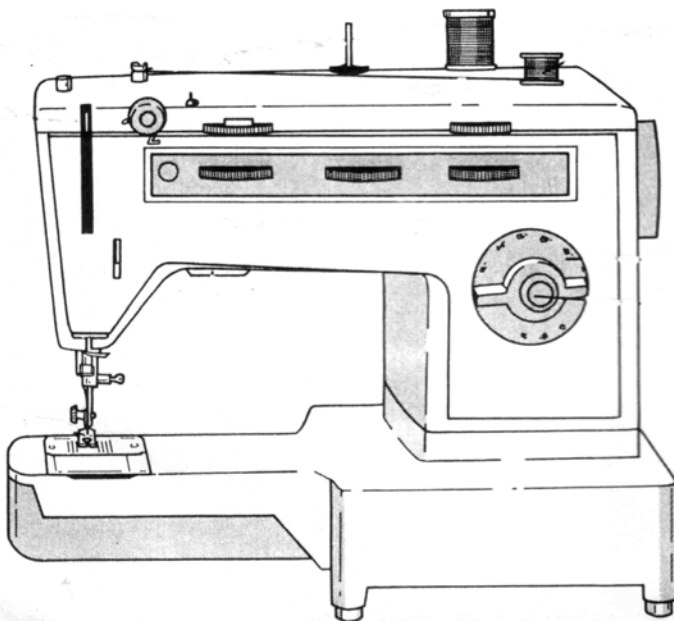

a. Thread the sewing machine in the diagram.

(5 marks)

b. Why is it important to thread the machine correctly?

\_\_\_\_\_  
\_\_\_\_\_ (2 marks)

c.

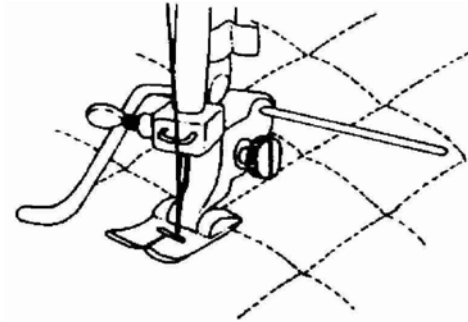
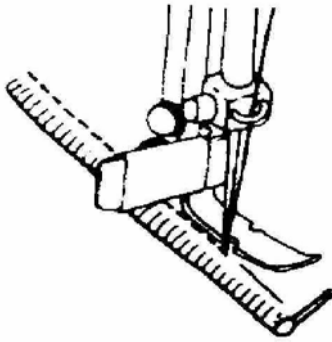

Name these **two** sewing machine attachments.  
Explain the use of each attachment.

**Name** \_\_\_\_\_

**Use** \_\_\_\_\_

**Name** \_\_\_\_\_

**Use** \_\_\_\_\_

(2, 2 marks)

5a. Name **three** ways in which fabric finishes contribute to the efficiency and safety of textiles in the home.

(i) \_\_\_\_\_

(ii) \_\_\_\_\_

(iii) \_\_\_\_\_

(3 marks)

b. Name a different fabric finish which can be applied to these items.

(i) Cushion cover \_\_\_\_\_

(ii) Anorak \_\_\_\_\_

(iii) Summer cotton shirt \_\_\_\_\_

(3 marks)

c. Give **one** important factor to be kept in mind when washing items which have a special finish.

\_\_\_\_\_ (2 marks)

d. Another method of improving fabric efficiency (*performance*) is to create a fabric blend.  
Name **two** popular fabric blends.

(i) \_\_\_\_\_ (ii) \_\_\_\_\_ (2 marks)

6. Look at this creative collage, and the sketch provided.

This worked sample shows how it was made into a creative collage. (*Diagram 1*)

This sketch shows simple shapes of poppy / seed heads and stems. (*Diagram 2*)

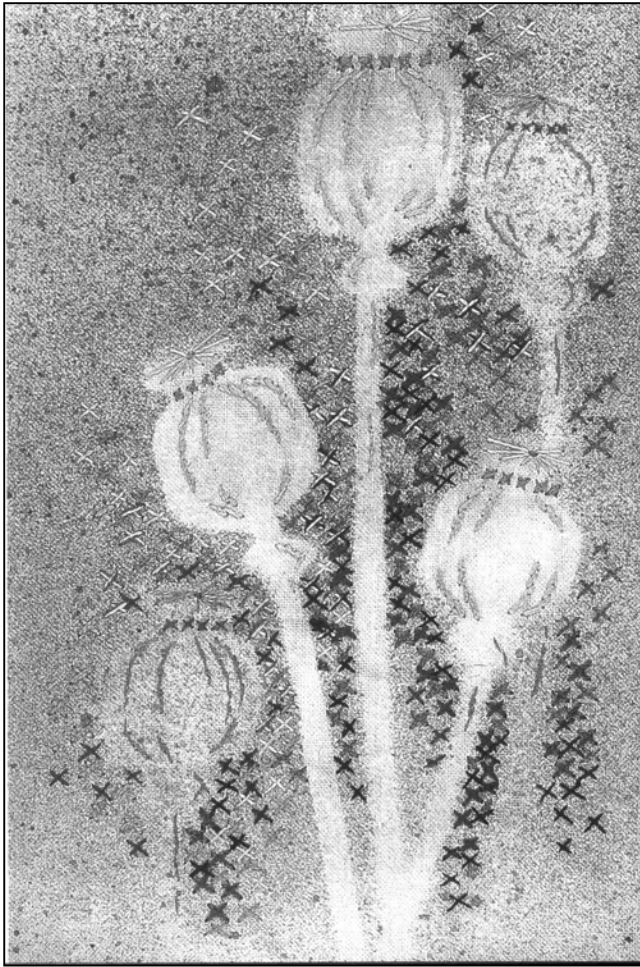

**Worked Sample Diagram 1**

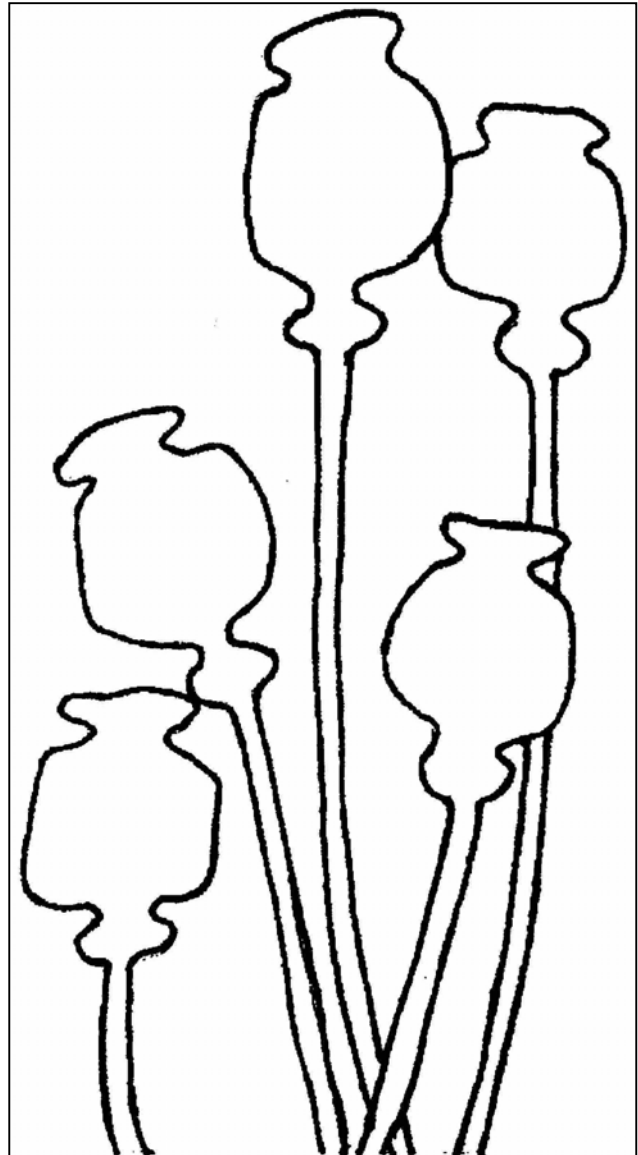

**Sketch Diagram 2**

a. Using the basic sketch, show how this simple design (*Diagram 2*) can be turned into another attractive wall hanging.

You can do this by:

(i) Adding leaves, shapes and lines to complete the design. (3 marks)

(ii) Create a colour scheme using **four** basic colours. (2 marks)

(iii) On this sketch:

Fill in **three** different embroidery stitches.

Name and draw each stitch. (3, 3 marks)

(iv) Fabrics can be applied to the sketch using the appliqué method.

Name **two** suitable fabrics that you can use. Label each fabric on the sketch (*Diagram 2*), showing the colour of each fabric and where it will be used. (1½, 1½ marks)

b. Using simple diagrams and notes, explain how appliqué is worked.

**Diagram**

**Notes**

(i) \_\_\_\_\_

(ii) \_\_\_\_\_

(iii) \_\_\_\_\_

(iv) \_\_\_\_\_

(2, 4 marks)

c. Where would you put this wall hanging?

\_\_\_\_\_ (1 mark)

d. Name **two** other decorations that can be used to enhance (*make nicer*) the design.

(i) \_\_\_\_\_ (ii) \_\_\_\_\_ (2 marks)

7. Recycling of textiles is considered very important as textiles can harm the environment.

a. How would you recycle the following items? Give ideas how to re-use the fabric. Draw sketches of your ideas.

**Sketches**

(i) a pair of curtains

**New Item** \_\_\_\_\_

(ii) a man's shirt

**New Item** \_\_\_\_\_

(iii) the fabric from a broken umbrella

**New Item** \_\_\_\_\_

(3, 3 marks)