

# JUNIOR LYCEUM ANNUAL EXAMINATIONS 2007

Educational Assessment Unit – Education Division

**Form 2**

**TEXTILES STUDIES**

**Time: 1h 30min**

Name: \_\_\_\_\_

Class: \_\_\_\_\_

1a. This is the design of a skirt.

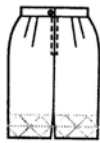
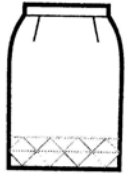

(i) Name the skirt

\_\_\_\_\_

(1 mark)

(ii) Suggest a suitable fabric for the skirt.

\_\_\_\_\_

(1 mark)

(iii) Give a reason for your choice

\_\_\_\_\_ (2 marks)

b. Using the template to help you, draw **two** other types of skirts. Name each skirt.



**Name:** \_\_\_\_\_

**Name:** \_\_\_\_\_

(2, 2 marks)

c. For which occasion would you use each skirt?

**Skirt 1:** \_\_\_\_\_

**Skirt 2:** \_\_\_\_\_

(2 marks)

d. The sides of the skirt are stitched using a plain seam. Draw diagrams and write how this seam is made up.

**Diagrams**

**Notes**

- (i) \_\_\_\_\_
- (ii) \_\_\_\_\_
- (iii) \_\_\_\_\_
- (iv) \_\_\_\_\_

(2, 4 marks)

e. Name this method of finishing a seam.

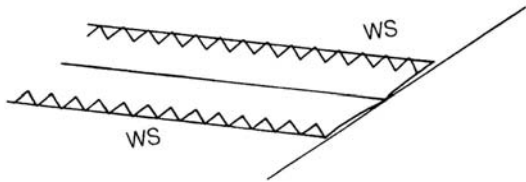

**Name:** \_\_\_\_\_ (1 mark)

f. Name **two** sewing notions needed to make the skirt.

- (i) \_\_\_\_\_
  - (ii) \_\_\_\_\_
- (2 marks)

g. The diagram shows the **three** measurements needed to make a skirt.

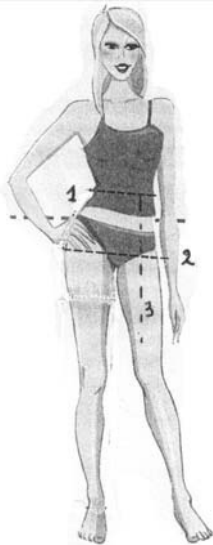

(i) Name the **three** measurements.

- 1. \_\_\_\_\_
- 2. \_\_\_\_\_
- 3. \_\_\_\_\_

(3 marks)

(ii) Name the tool used to take body measurements.

\_\_\_\_\_ (1 mark)

(iii) Name **one** important point to keep in mind when taking measurements.

\_\_\_\_\_ (1 mark)

h. Name and draw **three** permanent stitches.

	<b>Name</b>	<b>Draw</b>
(i)	_____	
(ii)	_____	
(iii)	_____	

(3, 3 marks)

i. Name these fasteners.

- (i) \_\_\_\_\_
- (ii) \_\_\_\_\_

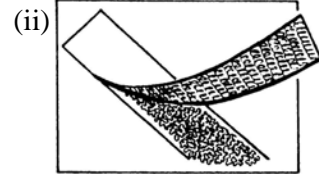
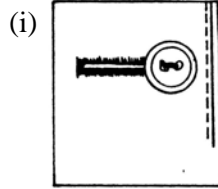

(2 marks)

j. Where would you use each fastener?

- (i) **Use** \_\_\_\_\_  
**Reason** \_\_\_\_\_

(1, 2 marks)

- (ii) **Use** \_\_\_\_\_  
**Reason** \_\_\_\_\_

(1, 2 marks)

2a. Thread the sewing machine in the picture.

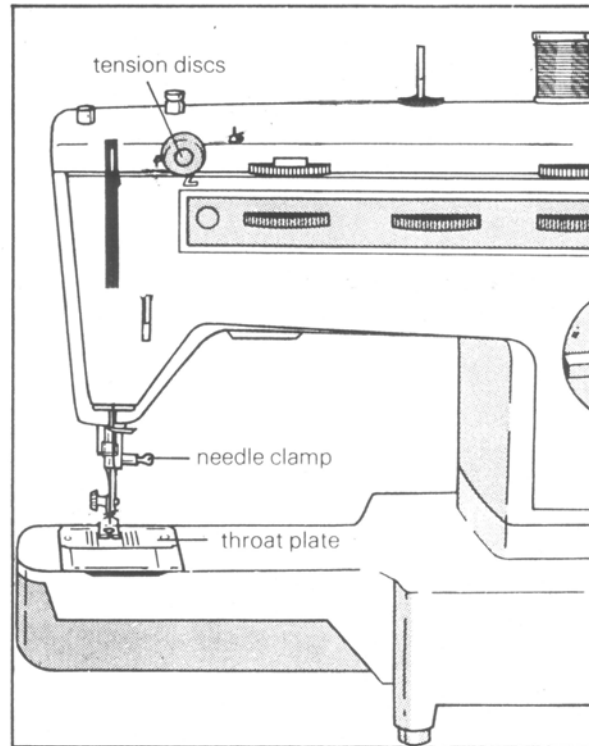

(5 marks)



b. Write **five** safety rules to be observed when using a sewing machine and/or an iron.

- (i) \_\_\_\_\_
- (ii) \_\_\_\_\_
- (iii) \_\_\_\_\_
- (iv) \_\_\_\_\_
- (v) \_\_\_\_\_

(5 marks)

3a. Last year's jeans is not fashionable anymore. Using these diagrams explain how you can recycle it by turning it into a gypsy skirt, using left over material to make the frills.

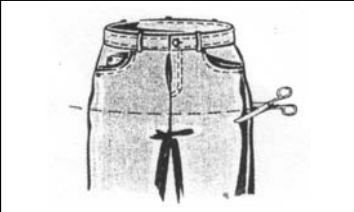
**JEANS MEET SKIRT**  
Creative recycling to give an old pair of your jeans a new lease on life ...

(i) \_\_\_\_\_  
 \_\_\_\_\_  
 \_\_\_\_\_

(ii) \_\_\_\_\_  
 \_\_\_\_\_  
 \_\_\_\_\_

(iii) \_\_\_\_\_  
 \_\_\_\_\_  
 \_\_\_\_\_

(6 marks)

b. List **three** things a consumer should think about when buying ready made clothes.

(i) \_\_\_\_\_  
 (ii) \_\_\_\_\_  
 (iii) \_\_\_\_\_

(3 marks)

c. Fashion changes very quickly. Give **two** reasons why you think this happens.

\_\_\_\_\_  
 \_\_\_\_\_

(2 marks)

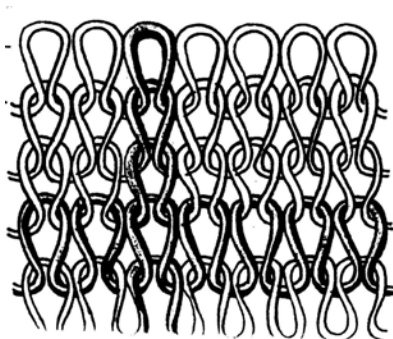

4a. Name the fabric construction in the diagram.

\_\_\_\_\_ (1 mark)

b. List **two** items of clothing that can be made with this method.

(i) \_\_\_\_\_  
 (ii) \_\_\_\_\_

(2 marks)

c. Many fabrics are made by weaving. Name and draw **two** different types of weaves.

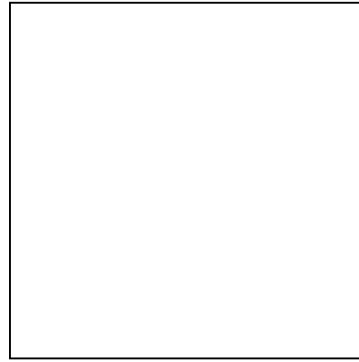
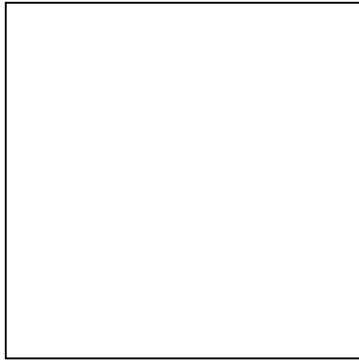

(i) \_\_\_\_\_

(ii) \_\_\_\_\_

(2, 2 marks)

d. Weaving can be done using ribbons. Name **two** other types of materials (*yarns*) you can use to make weaving.

(i) \_\_\_\_\_

(ii) \_\_\_\_\_

(2 marks)

e. Put these properties about different fabric construction under the right heading.

frays	stretches	ladders
strong	does not fray	clings to the body
has no grain ( <i>warp and weft</i> )	is made of two sets of yarns	tears easily

<b>Weaving</b>	<b>Knitting</b>	<b>Bonding</b>
(i) _____	(i) _____	(i) _____
(ii) _____	(ii) _____	(ii) _____
(iii) _____	(iii) _____	(iii) _____

(9 marks)

5. Tie and dye is a method of colouring fabric. It can be used to colour T-shirts.  
 a. Describe how you would tie and dye this T-shirt.



**Method of Tying**

\_\_\_\_\_ (1 mark)

**Method of Dyeing**

\_\_\_\_\_  
 \_\_\_\_\_  
 \_\_\_\_\_  
 \_\_\_\_\_ (4 marks)

At school you have dyed some cotton fabric. Explain how you can further decorate this design with embroidery stitches.

- b. Draw an item which you can make from this fabric. (2 marks)

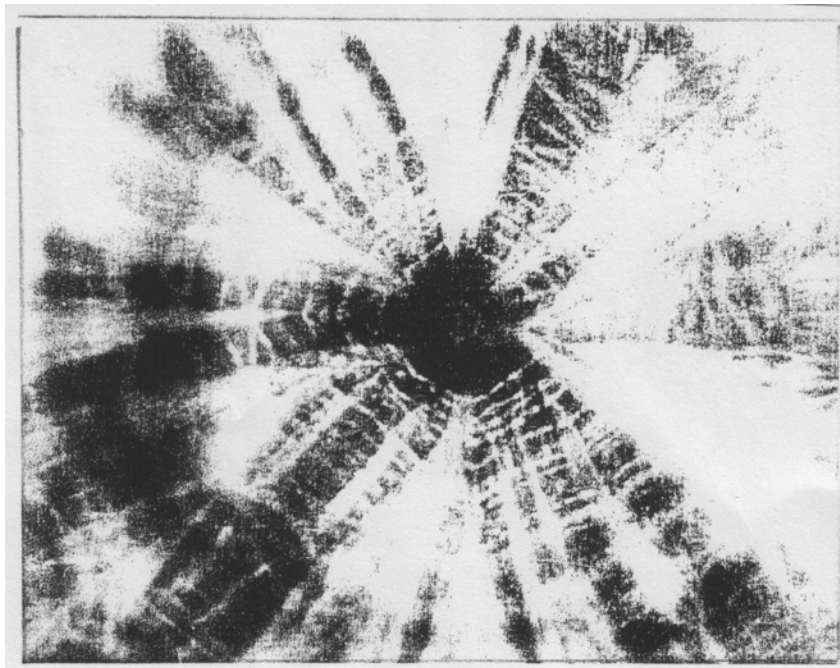

- c. Draw **four** embroidery stitches on the design.  
 d. On the design name each stitch used. (4, 4 marks)

Draw the item you would make from this dyed cloth.



e. How would you make sure that the dyed fabric keeps its colour well?

\_\_\_\_\_ (1 mark)

f. Name **one** other method of colouring fabric.

\_\_\_\_\_ (1 mark)

g. Cotton fabric can shrink the first time it is washed. Describe how you would test a sample of fabric to find out if it shrinks. Draw a diagram to support your answer.

Diagram

Method

(i) \_\_\_\_\_

(ii) \_\_\_\_\_

(iii) \_\_\_\_\_

(iv) \_\_\_\_\_

(2, 4 marks)