

JUNIOR LYCEUM ANNUAL EXAMINATIONS 2005

Educational Assessment Unit - Education Division

FORM 1

TEXTILES STUDIES

TIME: 1h 30min

Name: _____

Class: _____

1. All colours come from Primary Colours. Fill in the colour wheel in this way.

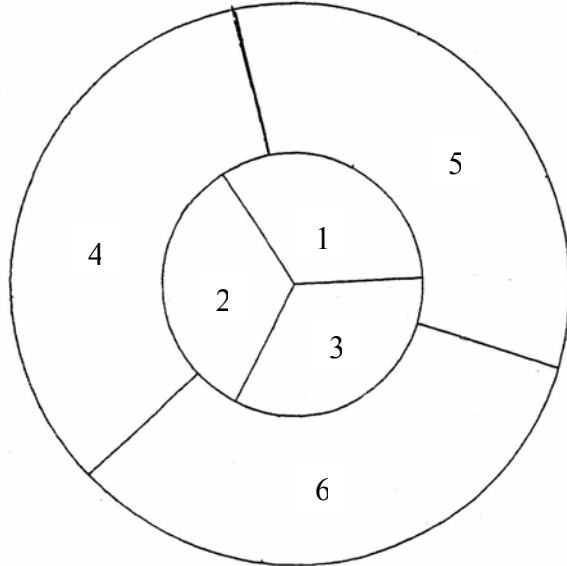

- a. In the centre, colour and name the **three** primary colours. (No. 1, 2, 3) (1½, 1½ marks)
- b. On the outer circle, colour and name the **three** secondary colours. (No. 4, 5, 6) (1½, 1½ marks)
- c. Look at the picture of this living room. This room is rather dark as no sun comes into the room during the winter months. Suggest a colour scheme for the soft furnishings in this room, to make it look brighter and warmer. Colours can be mix and match or one colour.



You need to suggest colours for the fabrics of the:

- (i) Curtain _____
- (ii) Carpet _____
- (iii) Sofas _____
- (iv) Chair covers _____
- (v) Cushions _____

(5 marks)

d. Describe how you would tie and dye a pair of cushions for the chairs. Use the diagrams to help you.

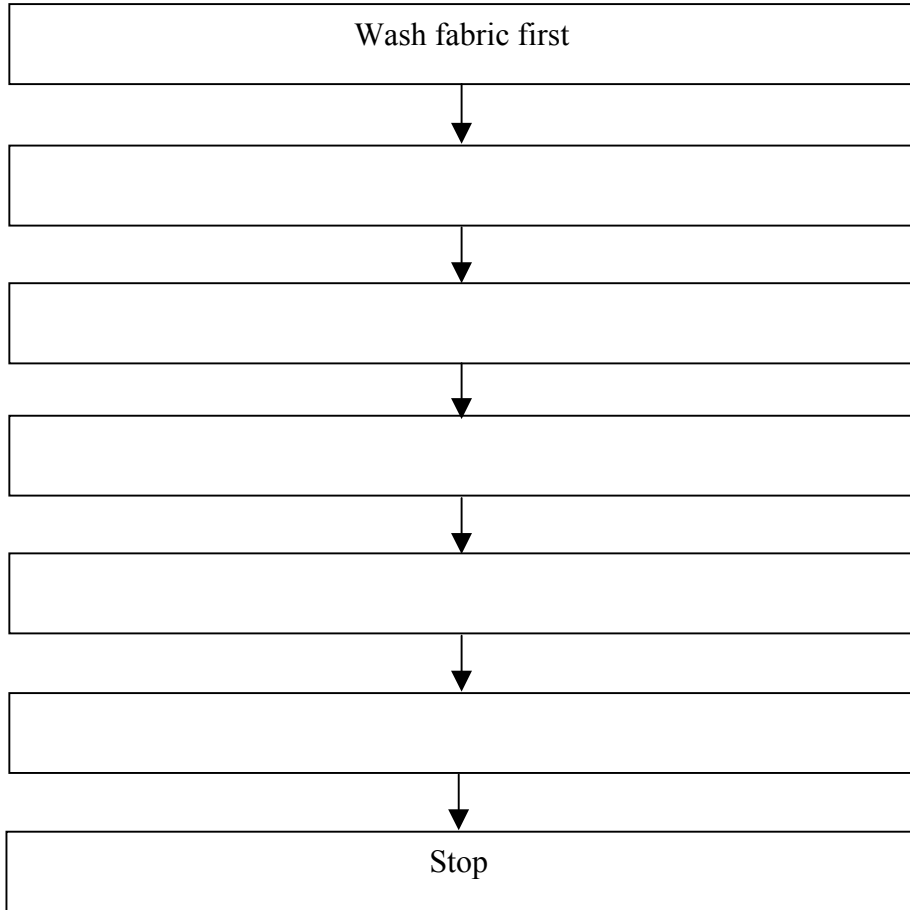
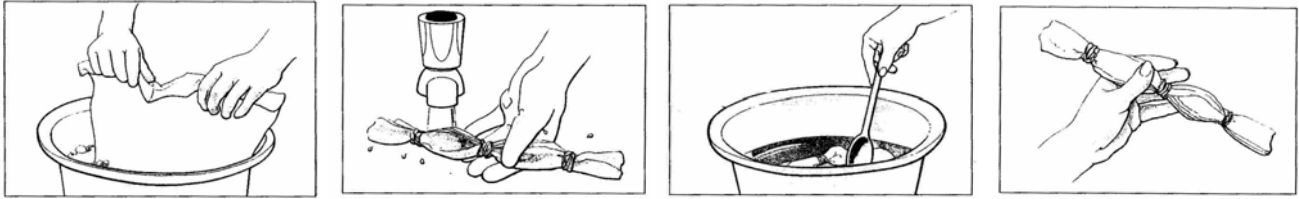

(5 marks)

e. What type of fabric would you choose for dyeing the cushions?
Give **one** reason for your choice.

Fabric _____

Reason _____ (1, 2 marks)

f. Name this label _____



(1 mark)

g. Name **three** types of clothing that are usually made from this fabric.

(i) _____ (ii) _____ (iii) _____ (3 marks)

h. This fibre is very flammable. Describe, with the help of a diagram, an experiment which you can carry out to test the flammability (*burning*) of a fibre.

Diagram

Method

- (i) _____
- (ii) _____
- (iii) _____
- (iv) _____

(2, 4 marks)

i. What should you keep in mind when buying children's toys?

(i) _____

(ii) _____ (2 marks)

2a. Look at this design. Describe how you would make up a wall hanging for the living room using this design.

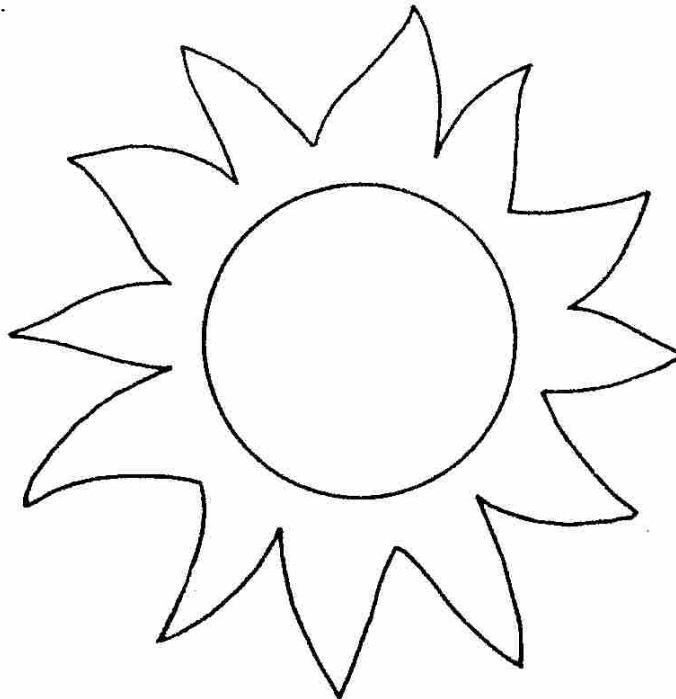

Suggest **two** types of fabrics you can use for the design. Name colour of background and fabric used.

	Type	Colour
Fabric for background	_____	_____
Fabric for sun (<i>design</i>)	(i) _____	_____
	(ii) _____	_____

(3, 3 marks)

b. Draw and name **three** embroidery stitches you can use to work your design. (*draw and name these on diagram*). (3, 3 marks)

c. Name **two** other things (*materials*) you can use to make the design more interesting.

- (i) _____
- (ii) _____

(2 marks)

d. How can you save money and help keep the environment clean when making this collage? Suggest things that can be recycled instead of throwing them away. Give **three** examples. **One** example has been done for you.

Example: Use fabric from old curtains for background of collage.

(i) _____

(ii) _____

(iii) _____

(3 marks)

3a. Draw the soft toy or bag you made at school this year. Suggest a suitable fabric for making this toy/bag. Give a reason for your choice of fabric.

Drawing

Fabric for toy/bag: _____

Reason: _____

(2, 1, 2 marks)

b. Which seam did you use to make this article?
Describe how to make the seam.

Name of seam _____

(1 mark)

Diagram

Notes

(i) _____

(ii) _____

(iii) _____

(iv) _____

(v) _____

(2, 5 marks)

c. Name the seam finish in the diagram.

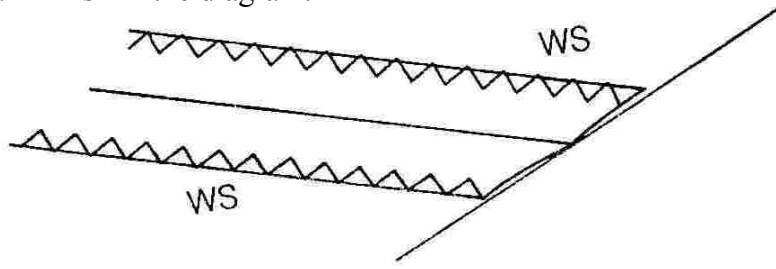

(1 mark)

d. Name **two** consumer rights you are protected with when buying soft toys for children.

(i) _____

(ii) _____ (2 marks)

4a. Name these **four** basic small tools needed when making your own clothes at home. Give the use of each tool.

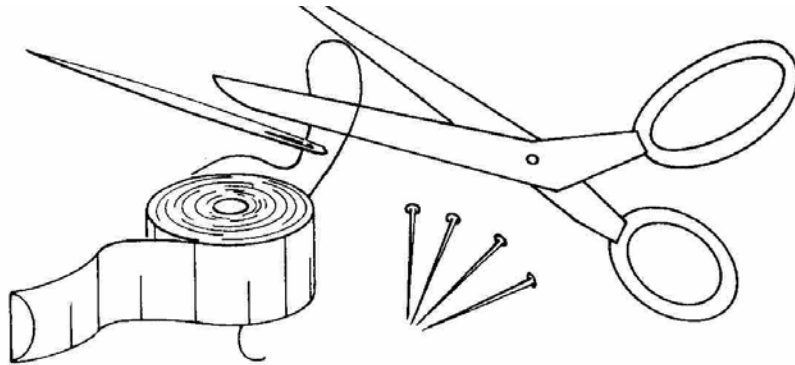

Name

Use

(i) _____

(ii) _____

(iii) _____

(iv) _____

(4, 4 marks)

b. Name and draw **three** other small tools found in the Needlework box.

Name

Use

(i) _____

(ii) _____

(iii) _____

(3, 3 marks)

c. Knowing your sewing machine is important to help you use it properly. Identify (*name*) any **five** parts of the sewing machine marked with an arrow. Give the use of each part. (*mark parts on diagram*).

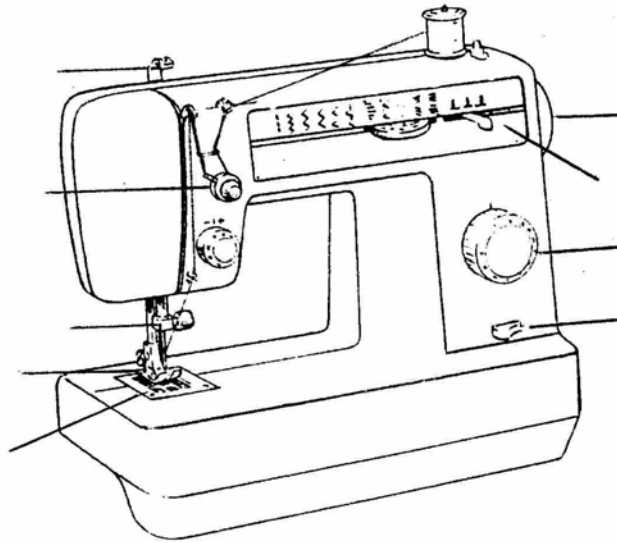

Name of Part	Use
(i) _____	_____
(ii) _____	_____
(iii) _____	_____
(iv) _____	_____
(v) _____	_____

(5, 5 marks)

d. Name **two** sewing machine attachments you might find in your sewing machine tool box.

(i) _____ (ii) _____ (2 marks)

e. Name and draw **two** temporary (*tacking*) stitches.

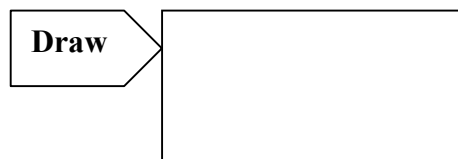
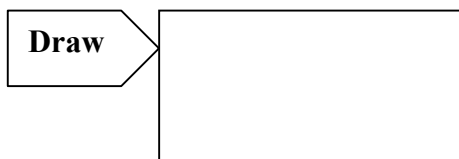

Name _____ Name _____ (2, 2 marks)

f. Name and draw **three** permanent stitches.

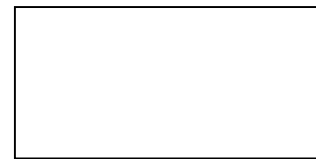

Name _____ (3, 3 marks)