

JUNIOR LYCEUM and SECONDARY SCHOOL
ANNUAL EXAMINATIONS 2006
Educational Assessment Unit – Education Division

FORM 3 (1st year) TECHNICAL DESIGN Time: 2 hours

NAME : _____

CLASS : _____

Instructions

- Write your name and class on all sheets.
- Attempt **ALL** questions.
- All answers are to be drawn accurately, with instruments, unless otherwise stated.
- All construction lines **MUST** be left on each solution to show the method employed.
- Drawing aids may be used.
- **You are required to use one side of your paper for question number 1 only.**
- Colour / shading should be used where appropriate.

Information

- All dimensions are in millimetres.
- Estimate any dimension not given.
- Marks will be awarded for accuracy, clarity and appropriateness of construction.

Question	1	2	3	4	5
Max. mark	45	15	14	10	16
Mark					

1. The figure below shows a pictorial view of a **SLIDE BRACKET**. To the dimensions given and using **First Angle Projection**, draw the following views:

- (a) a front elevation as seen from direction of arrow **A**.
(In this view only insert all hidden details). 15 marks
- (b) an end elevation as seen from direction of arrow **B**. 15 marks
- (c) a complete plan. 11 marks
- (d) the appropriate **Symbol** to show the projection angle used. 3 marks
- (e) The **Scale** used. 1 marks

Note: Hidden details to be shown in view (a) only.

Total 45 marks

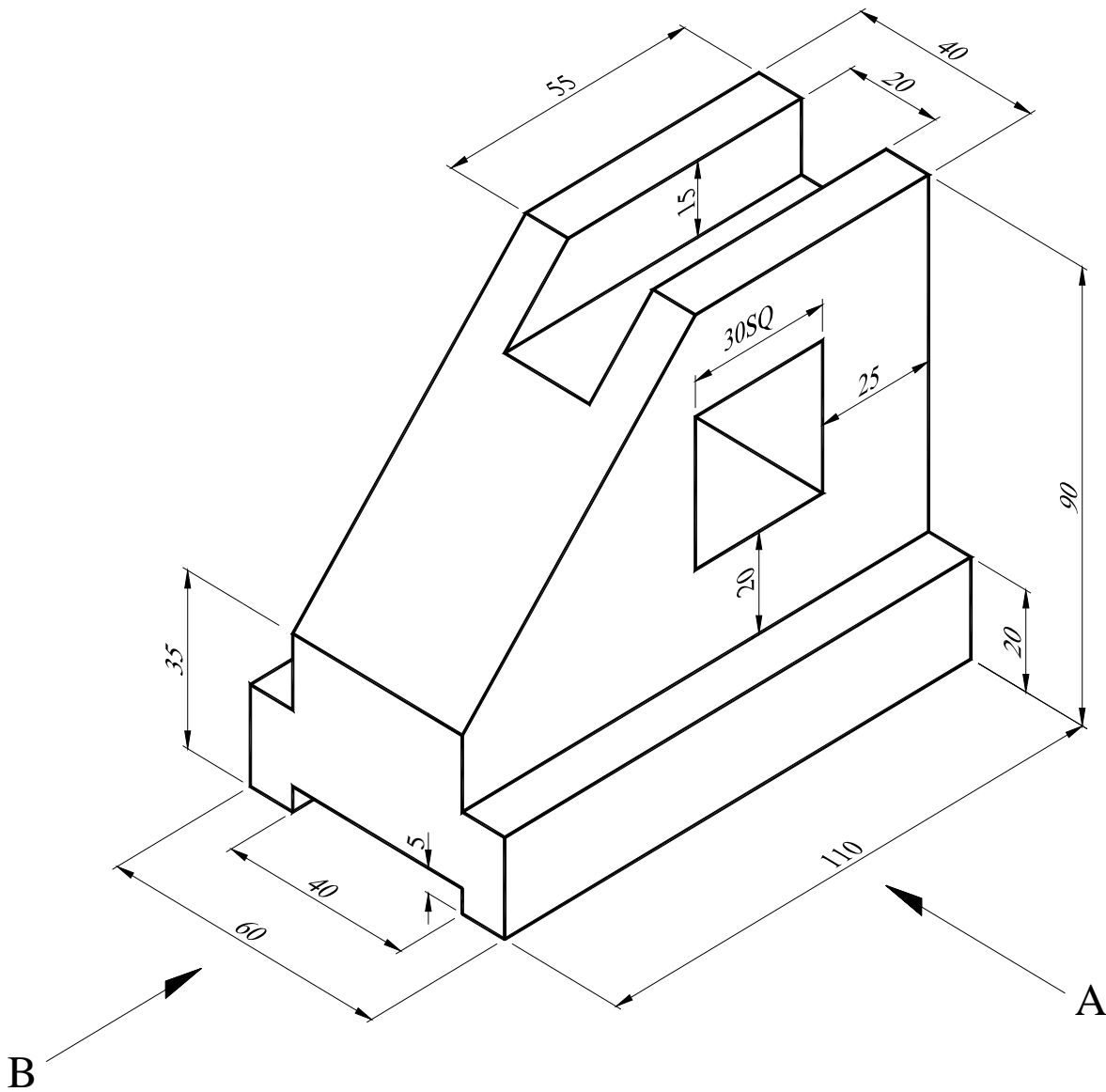

2. (a) Draw a triangle **ABC** having base **AB** 85mm, side **BC** 80mm and base angle **ABC** **45°**.
- (b) Construct the circumscribed circle for the triangle which passes through the points A, B and C.
- (c) Leave all construction lines in your solution to show the method used.

15 marks

3. Figure 2 below shows a solid component in third angle projection. Draw the component in **Cabinet Oblique** projection. Face '**A**' to be drawn in the foreground.

14 marks

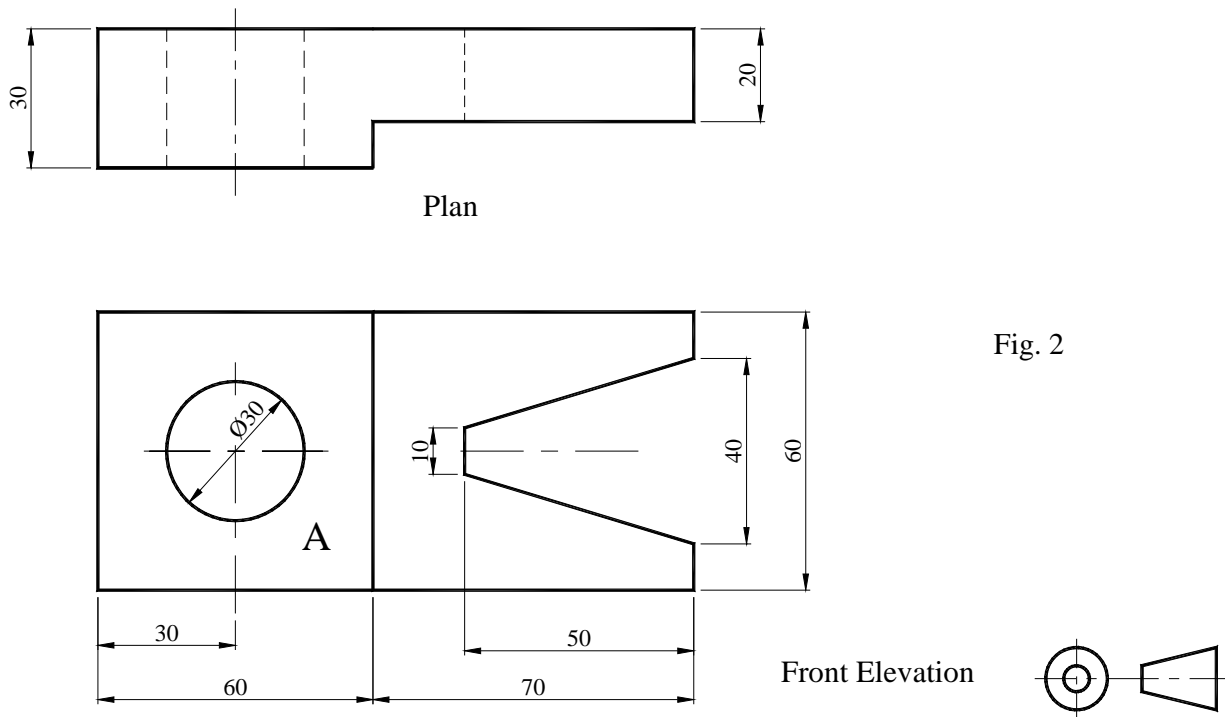
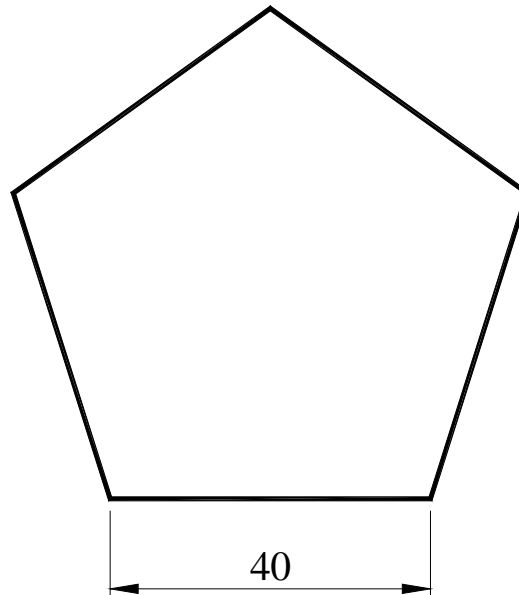

Fig. 2

4. The figure below shows a regular pentagon. Using any method you learned, copy the figure and enlarge it so that the 40mm side is enlarged in the ratio of **5 : 3** while keeping the same proportions.

10 marks



5. The table below shows the number of **BOYS** and **GIRLS** that attended an activity during the scholastic year 2004 / 2005.

	January	February	March	April	May	June
GIRLS	15	45	30	20	30	40
BOYS	30	50	20	35	40	45

- (a) Draw **line graphs** to show a comparison of the attendance by the **Girls** and **Boys** for all the months given.
- (b) Add suitable colour and notation to your graphs.

16 marks