

JUNIOR LYCEUM ANNUAL EXAMINATIONS – 2006

Educational Assessment Unit – Education Division

FORM 5 MATHEMATICS (Non Calculator Paper – Option B) TIME: 20 minutes

Name: _____

Class: _____

Mark

INSTRUCTIONS TO CANDIDATES

- **Answer all questions. There are 20 questions to answer.**
 - **Each question carries 1 mark.**
 - **Calculators, rulers, protractors and other mathematical instruments are not allowed.**
 - **You are not required to show your working. However space for working is provided if you need it.**
-

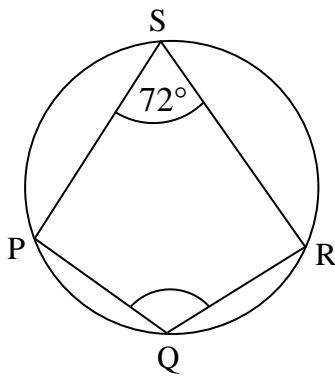
No.	QUESTION	SPACE FOR WORKING (IF REQUIRED)
1.	Find the value of $8 \cdot 3 - 2 \times 4$. Ans:_____	
2.	The exterior angle of a regular polygon is 36° . This regular polygon has: (A) 5 sides (B) 6 sides (C) 8 sides (D) 10 sides. Ans:_____	
3.	What is the next even number after 88 ? Ans:_____	
4.	In a bag there are 4 yellow marbles and 8 green marbles. Kenneth picks a marble at random from the bag. What is the probability that Kenneth picks a yellow marble? Ans:_____	
5.	Given that $58 \times 7.8 = 452.4$, what is the value of 5.8×78 ? Ans:_____	
6.	Which of the following is the best estimate for the volume of a cylinder of radius 4 cm and height 5 cm? (A) 120 cm^3 (B) 240 cm^3 (C) 120 cm^2 (D) 240 cm^2 . Ans:_____	
7.	Given that $f(x) = 7x + 5$ find the value of $f(3)$. Ans:_____	
8.	4% of a certain sum of money is Lm18. What is the value of 6% of the same sum of money? Ans:_____	
9.	 <p>PQRS is a cyclic quadrilateral in which $\angle PSR$ is 72°.</p> <p>What is the size of $\angle PQR$?</p> <p>Ans:_____</p>	

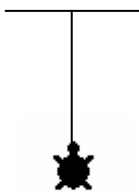
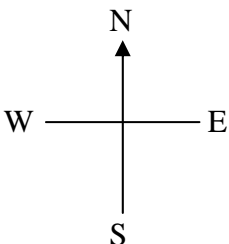
No.	QUESTION	SPACE FOR WORKING (IF REQUIRED)
10.	<p>The turtle starts at the position shown. The turtle is given a set of LOGO commands and draws the figure as shown.</p> <p>PD FD 100 RT 90 FD 50 ____ 100 PU HOME</p> <p>Which one of the following is the missing command? (A) FD (B) BK (C) RT (D) LT.</p> <p>Ans:_____</p>	
11.	<p>Adrian was using a spreadsheet. In cell A1 he typed 30. In cell B1 he typed 32. In cell C1 he typed 34. Choose the correct formula that Adrian would type in cell D1 to obtain the average of the entries in cells A1, B1 and C1.</p> <p>(A) = A1+B1+C1 (B) = A1+B1+C1/3 (C) = A1 B1 C1 / 3 (D) = (A1+B1+C1)/3.</p> <p>Ans:_____</p>	
12.	<div style="display: flex; align-items: center;"> <div style="margin-right: 20px;">  </div> <div> <p>Maria was facing SW. She turned 90° clockwise. What direction is she now facing?</p> <p>(A) NW (B) NE (C) SE (D) SW.</p> <p>Ans:_____</p> </div> </div>	
13.	<p>The marks obtained by 7 pupils in a Mathematics test were 2, 3, 4, 5, 6, 6, 8. John was one of these pupils and he obtained 5 marks. John's mark is the:</p> <p>(A) mean (B) mode (C) median (D) range.</p> <p>Ans:_____</p>	
14.	<p>Which of the following is the best estimate for $\sqrt{64 + 16}$?</p> <p>(A) 12 (B) 9 (C) 8 (D) 4.</p> <p>Ans:_____</p>	

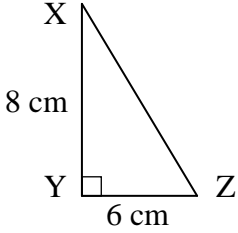
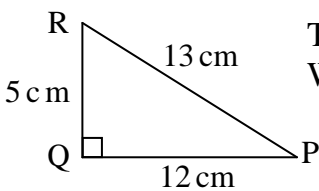
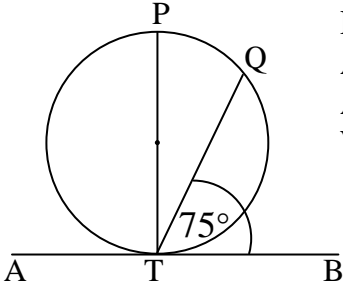
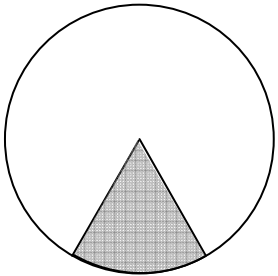
No.	QUESTION	SPACE FOR WORKING (IF REQUIRED)
15.	 <p>Triangle XYZ is right-angled at Y. YZ is 6 cm long and XY is 8 cm long. What is the length of XZ?</p> <p style="text-align: right;">Ans: _____</p>	
16.	<p>The angles of a triangle are in the ratio of 2 : 3 : 4. The size of the smallest angle is:</p> <p>(A) 9° (B) 40° (C) 80° (D) 120°.</p> <p style="text-align: right;">Ans: _____</p>	
17.	 <p>Triangle PQR is right-angled at Q. What is the value of $\cos P$?</p> <p style="text-align: right;">Ans: _____</p>	
18.	 <p>PT is a diameter of the circle. ATB is a tangent to the circle at T. Angle BTQ is 75°. What is the size of angle PTQ?</p> <p style="text-align: right;">Ans: _____</p>	
19.	<p>Does the point with coordinates (2 , 5) lie on the straight line graph of $y = 3x - 1$?</p> <p style="text-align: right;">Ans: _____</p>	
20.	 <p>The area of a circle is 330.6 cm^2. Find the area of the shaded sector of the circle if the angle at the centre is 60°.</p> <p style="text-align: right;">Ans: _____</p>	

JUNIOR LYCEUM ANNUAL EXAMINATIONS – 2006

Educational Assessment Unit – Education Division

FORM 5 MATHEMATICS (Main Paper – Option B) TIME: 1hour 40minutes

1	2	3	4	5	6	7	8	9	10	11	12	13	Total Main	Non- Calculator	GLOBAL MARK

DO NOT WRITE ABOVE THIS LINE

Name: _____

Class: _____

**CALCULATORS ARE ALLOWED BUT ALL NECESSARY WORKING MUST BE SHOWN.
ANSWER ALL QUESTIONS.**

1. a) Write 0.625 as a **fraction in its lowest terms**.

b) (i) Write the following numbers correct to **1 significant figure** to give an **estimate** for **P**.

$$P = \frac{(24.37 \times 39.26)^2}{35.73 \times 79.37}$$

(ii) Use your calculator to work out the value of **P** correct to **3 significant figures**.

_____ (4 marks)

2 a) Complete the sequence:

7, 10, 13, 16, _____, _____.

b) The n th term for the sequence above is $3n + 4$. Find the 20th term of the sequence.

_____ (4 marks)

3. a) A shopkeeper bought a washing machine for Lm240. He then sold it at a profit of 15%.

Work out:

(i) the selling price of the washing machine

(ii) the profit.

b) Aaron used a spreadsheet to calculate the interest on his Savings Account.

He entered the following data:

	A	B	C	D	E
1	Principal (Lm)	Rate (%)	Time (Years)	Interest (Lm)	
2	800	1.5	2	= A2*B2*C2/100	
3					

What value did Aaron obtain in cell **D2**?

(5 marks)

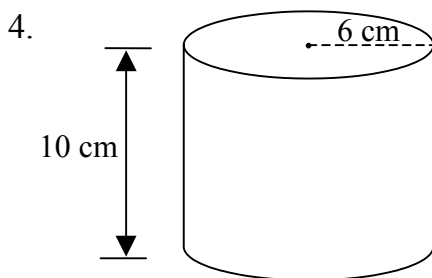

A cylinder has a radius of 6 cm and a height of 10 cm.

Work out:

a) the **volume** of the cylinder, correct to the **nearest whole number**

b) the **curved surface area** of the cylinder, correct to **one decimal place**.

(4 marks)

5. The formula for the area of a trapezium is: $A = \frac{1}{2}(a + b)h$.

a) Work out the area of a trapezium when $a = 12.5$ cm, $b = 17.5$ cm and $h = 8$ cm.

b) Make h the subject of the formula.

(4 marks)

6. *Use ruler and compasses only. All construction lines and arcs must be clearly shown.*

- Construct a triangle ABC in which $AB = 8.5$ cm, $BC = 4$ cm, and $\angle ABC = 90^\circ$.
- Construct the perpendicular bisector of BC. Let this bisector meet AC at D.
- Measure and write down the size of $\angle BDC$.

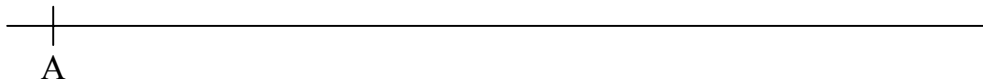

(5 marks)

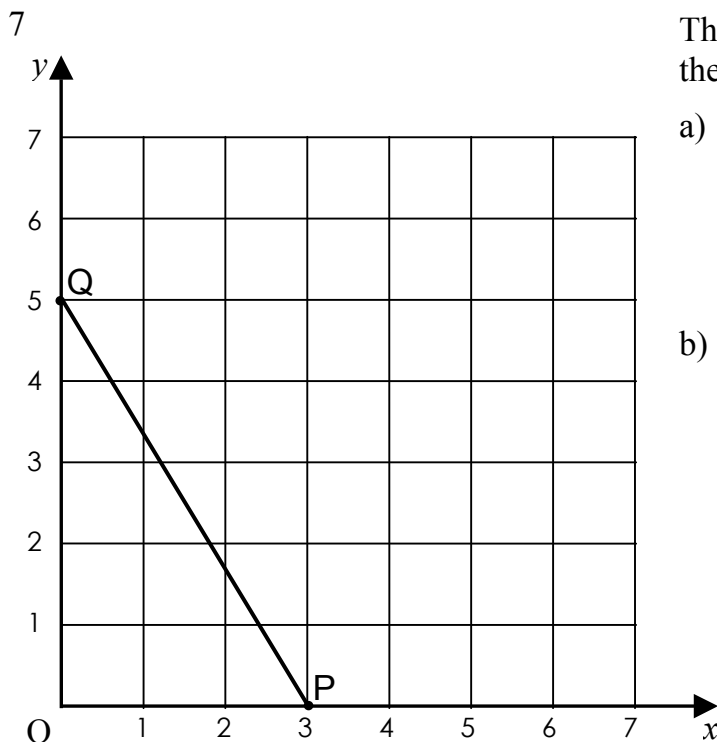

The figure shows a straight line graph that cuts the x -axis at P and the y -axis at Q.

a) Write down:

(i) the coordinates of P $P = (\quad , \quad)$

(ii) the coordinates of Q. $Q = (\quad , \quad)$

b) Work out, showing **all your working**

(i) the area of ΔPOQ

_____ units²

(ii) the length of PQ. (correct to 1 d.p.)

_____ units

(6 marks)

8. Two ordinary 6-sided dice are tossed.

a) **Complete** the possibility space diagram to show all the outcomes.

		2 nd dice					
		1	2	3	4	5	6
1 st dice	1	(1, 1)	(1, 2)	(1, 3)	(1, 4)	(1, 5)	(1, 6)
	2	(2, 1)	(,)	(2, 3)	(2, 4)	(2, 5)	(2, 6)
	3	(3, 1)	(3, 2)	(,)	(3, 4)	(3, 5)	(3, 6)
	4	(4, 1)	(4, 2)	(4, 3)	(,)	(4, 5)	(4, 6)
	5	(5, 1)	(5, 2)	(,)	(5, 4)	(5, 5)	(5, 6)
	6	(,)	(6, 2)	(6, 3)	(6, 4)	(6, 5)	(6, 6)

b) Use the possibility space diagram to find the probability of obtaining:

(i) a **double** _____

(ii) a **total score** of 8 _____

(iii) at **least one** prime number. _____

(6 marks)

9. A ship sails 30 km on a bearing of 030° from A to B.

The ship then sails 10 km from B to C.

a) How far is B East of A? (distance x)

b) C is 22 km East of A.

(i) How far is C East of B? (distance y)

(ii) Work out the bearing of C from B. Give your answer correct to the nearest degree.

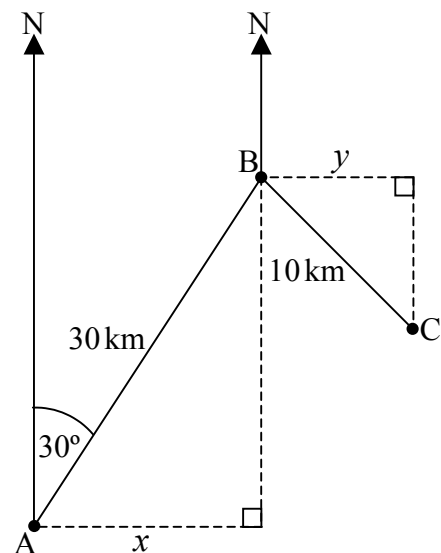
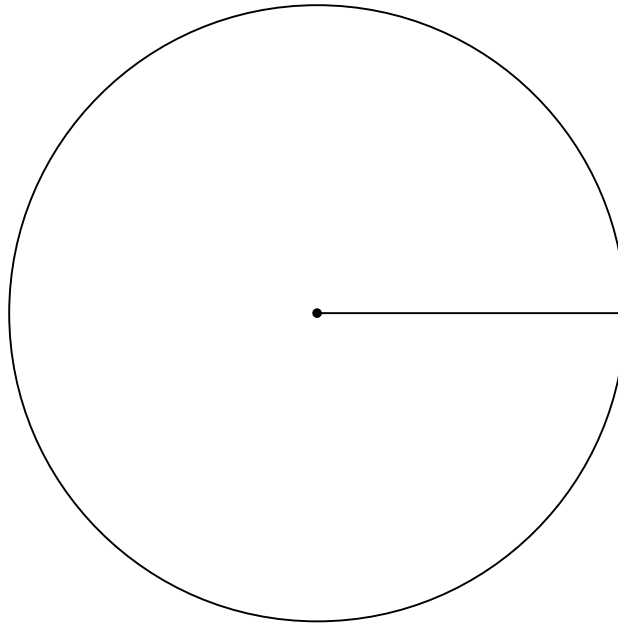

Diagram **NOT** drawn to scale

(6 marks)

10 a) In a local election candidate A received three-eighths of the votes, candidate B received one-third of the votes, candidate C received one-quarter of the votes and candidate D received the remainder.

(i) Draw an accurate and clearly labelled pie chart to represent this information.
Use the circle below.



(ii) If candidate B obtained 320 votes, how many people voted altogether?

b) The mean weight of a group of 17 teenagers is 45.5 kg. Joanne joins the group. The mean weight of the 18 teenagers **now** is 45.9 kg. Work out Joanne's weight.

(9 marks)

- 11 Triangle ABC is an equilateral triangle inscribed in a circle centre O.

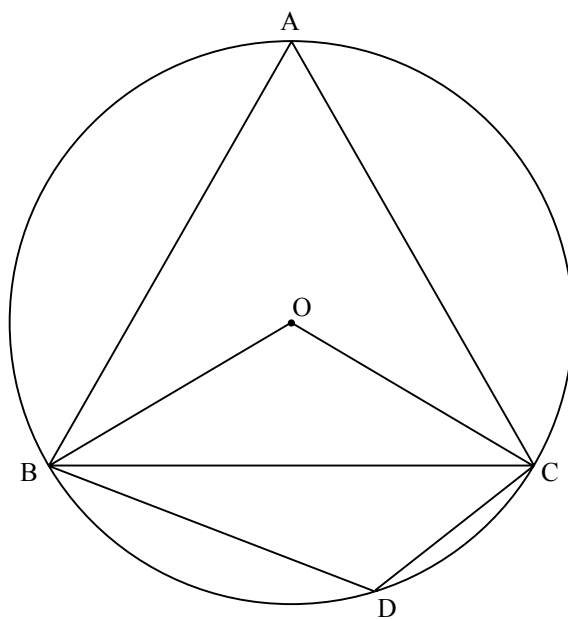

- a) **Show all your working and give reasons for your answers.**
Find each of the following angles:

(i) angle AOB

(ii) angle ADB

- b) The radius of the circle is 5 cm.
Work out, correct to **three significant figures**, the area of the **minor sector OBC**.

(7 marks)

12. a) The diagram shows a ramp of uniform cross-section. $AB = 18$ m, $BC = 16$ m, $CD = 13$ m and $BY = 9$ m.

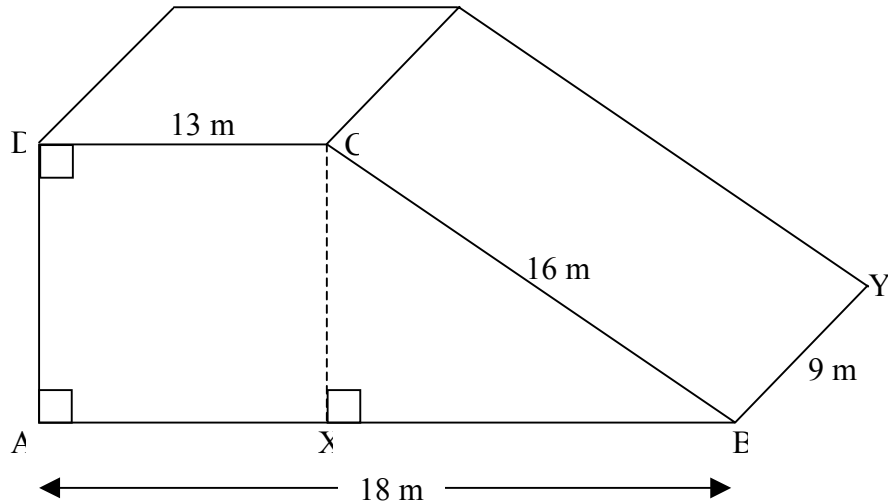

Work out, correct to **three significant figures**:

(i) the height CX

(ii) the area of the cross-section, $ABCD$

(iii) the volume of the ramp.

- b) The figure shows the path traced out by the **LOGO** turtle. The turtle starts at A and travels to D passing through B and C .

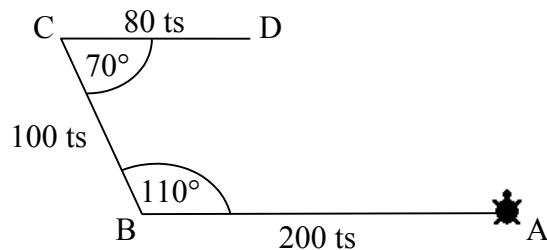

Complete this set of **LOGO** commands to trace this journey.

PD LT 90 FD 200 RT ____ FD 100 ____ 110 FD ____ PU HOME

(9 marks)

13. a) On the grid provided, **plot** and **join** the points A (3 , 2), B(6 , 2) and C(3 , 7) to obtain triangle ABC.
- b) **Reflect** triangle ABC in the y -axis. Label the corresponding vertices of the image A'B'C'.
- c) **Rotate** triangle ABC through 90° clockwise about (0 , 0). Label this image R.
- d) Plot and draw the points (-2 , -4), (-5 , -4) and (-2 , 1) and label this figure T. Write down the column vector by which triangle A'B'C' is **translated** to obtain figure T.

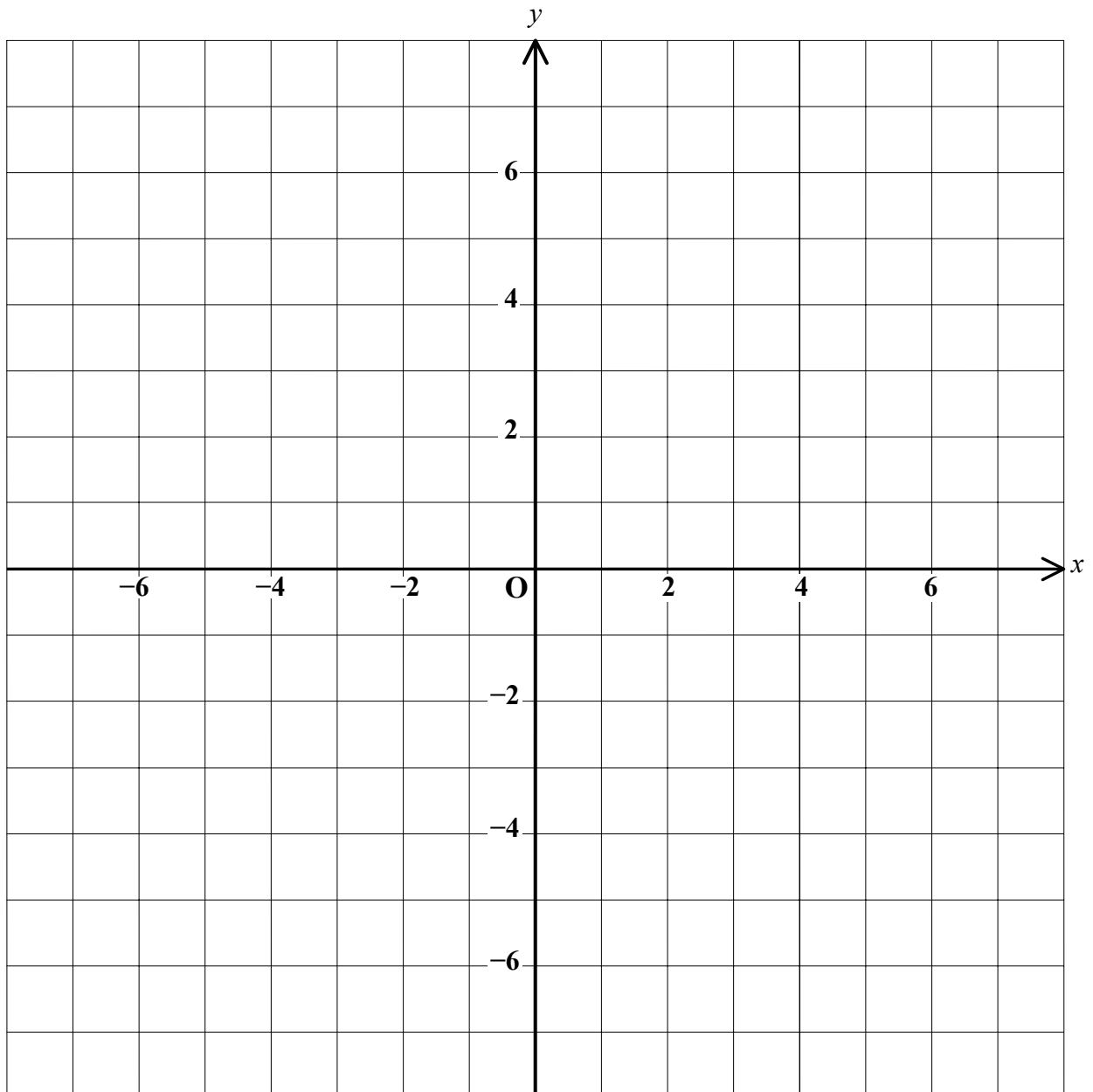

(11 marks)

End of paper