

THE JOINT EXAMINATION BOARD

PAPER P6

INFRINGEMENT AND VALIDITY OF UNITED KINGDOM PATENTS

Tuesday 08th October 2013

10.00 a.m. – 3.00 p.m.

Please read the following instructions carefully. **Time Allowed – 5 HOURS**

1. You should respond to the instructions given at the end of the client's letter.
2. Please note the following:
 - a. Enter the Paper Number (P6) and your Examination number in the appropriate boxes at the top of each sheet of paper;
 - b. The scripts are photocopied for marking purposes. Please write with a **dark inked pen** on one side of the paper only and within the printed margins, and do not use highlighters in your answer;
 - c. Do not state your name anywhere in the answers;
 - d. Write clearly, examiners cannot award marks to scripts that cannot be read;
 - e. **Marks are awarded for the reasoning displayed and the points selected for discussion rather than the conclusions reached.**
 - f. You must number all the pages of your answer script. Once the exam finishes, an **additional** 5 minutes will be allowed for you to do this.
3. Under the Examination Regulations **you may be disqualified from the examination and have other disciplinary measures taken against you if:**
 - a. you are found with unauthorised printed matter or other unauthorised material in the examination room;
 - b. your mobile phone is found to be switched on;
 - c. you copy the work of another candidate, use an electronic aid, or communicate with another candidate or with anyone outside the examination;
 - d. you continue to write after being told to stop writing by the invigilator(s). **NO WRITING OF ANY KIND IS PERMITTED AFTER THE TIME ALLOTTED TO THIS PAPER HAS EXPIRED.**
4. **At the end of the examination assemble your answer sheets in question number order, number all the pages and put them in the WHITE envelope provided.** Do not staple or join your answer sheets together in any way. Any answer script taken out of the examination room will not be marked.

Documents:	Client's letter	(01 page)
	Document A (GB1234567)	(06 pages)
	Document B (Wasteaway Technical Flyer)	(03 pages)
	Document C (US5555555)	(06 pages)

This paper consists of 17 pages in total, including this page.

Client's Letter

Dear Attorney,

Thanks for your help in getting our patent granted (Document A) in two years. Our domestic water cleaning products, which we sell with our standard water butts, are not selling as well as we hoped. However, our commercial products have really taken off, with sales in the UK well ahead of our best predictions. Whilst we hope that UK sales for both products will increase, our focus for now is on expanding sales of the larger capacity units, both in the UK and abroad.

I now have another related matter that I would like your assistance with. Just last week I attended a trade show where I saw a stand for a company called Wasteaway. I had not heard of them before but they were showing a water cleaning apparatus, the CleaniO. I must say that I was not impressed with the CleaniO product, it is cheaply made and not very robust. Also, although the CleaniO is for use with a water butt, Wasteaway don't sell butts. Because of this, the price for a CleaniO is significantly lower than our starting price. I picked up a Technical flyer explaining the CleaniO which I attach for your consideration (Document B).

In conversation with the managing director of Wasteaway I told him about our patent. He seemed a bit shocked that we had a patent but made no further comment. I thought we left on fairly good terms.

Anyway, today I have received a letter from Wasteaway's patent attorney claiming that our patent is invalid over the attached US patent (Document C). The letter also states that I threatened the managing director with patent infringement proceedings!

I can't see that there is anything to be done here but I would welcome your input. I can be at your offices next week to discuss.

Regards

Sol Pipe

You have undertaken further searches and have confirmed that US5555555 (Document C) is the most relevant prior art. Document C does not have any equivalents.

Your task is to prepare a memorandum in advance of the meeting. Your memorandum should include notes on infringement and validity in the UK only and brief notes on possible steps to be taken to help your client.

GB 1234567

(Filed 01 September 2010, Granted 24 September 2012)

5

Water Cleaning

This invention relates to water cleaning apparatus, particularly apparatus for cleaning domestic and other waste water.

10 It is well known that lots of domestic water is wasted. It is also known that rain water is often not harvested by home owners, or indeed from commercial premises, where roof spaces are significantly larger and thus volumes of water to be collected are significantly larger.

15 It is an object of the present invention to provide a simple apparatus to help harvest waste water at source for its re-use.

According to a first aspect of the invention, there is provided apparatus for cleaning water, the apparatus comprising a holding tank with a central aperture through which
20 extends an upstanding pipe, the uppermost edge of which providing a weir, the holding tank having a filter material provided across its top.

The holding tank preferably has a base or lowermost wall which slopes towards the aperture.

25

The filter material is preferably a mesh, typically fabricated from steel or other metal material and having a mesh hole size of 1 to 10 mm, for example from 5 to 10 mm. Advantageously, the mesh extends across the whole of the holding tank to allow
impinging water to flow into the holding tank.

30

The components of the apparatus are preferably all formed from rigid weather and corrosion resistant materials.

The pipe may be movable to help with cleaning of the holding tank.

A second aspect of the invention provides water cleaning and storage apparatus comprising a water storage tank having a top wall through which a pipe extends, the
5 other end of the pipe providing a weir, a peripheral wall upstands from the storage tank to provide a holding tank and wherein a filter material is secured over and between the peripheral wall.

In order that the invention may be more fully understood it will now be described with
10 reference to the accompanying drawings, in which:

Figure 1 is a schematic section through a first embodiment of the invention, and
Figure 2 is a schematic section through a second embodiment of the invention.

Referring first to Figure 1, there is shown water cleaning apparatus 1 according to
15 the invention.

The apparatus 1 comprises a circular holding tank 10 which has a base 11 and a wall 12. The base 11 slopes downwardly towards a central aperture 13. The aperture
20 13 is closed by a vertically disposed and fixed tube 14 which extends both up from and below the aperture.

The cylindrical wall 12 is of a size such that a sizeable volume of water may be held within the holding tank 10. For domestic use that may be, for example 5 to 10 litres. In commercial embodiments it may be significantly more.
25

Provided along the top edge 15 of the holding tank 10 is an annular bracket 20 which is permanently secured to the wall 12 by screws, bolts or the like. The bracket 20 serves two purposes as will be outlined below.

30 Provided on the bracket 20 is a fixing 21 to which a downpipe DP may be secured to ensure the downpipe DP is fixed in relation to the holding tank 10.

Importantly, the bracket 20 has a ledge 22 on which a mesh 23 lies to cover the holding tank 10. The ledge 22 is located at or near the top edge 15.

In use, waste water (for example that flowing off of a roof) flows down downpipe D and flows over the mesh 23. Any relatively large entrained detritus such as moss, leaves and so on will usually be stopped on the mesh 23.

5

The filtered water will run into the holding tank 10 where it will stay until the level of water in the tank is sufficient for the water to run over a weir provided by the upper end of the cylindrical tube 14 whereupon it will flow by gravity into a storage vessel (not shown) such as a water butt for domestic use or a storage tank for commercial use.

10

Because of the time taken for the water to fill the holding tank 10, any smaller particles will settle out from held water, as indicated at SP.

15 The mesh 23 may be easily removed for maintenance purposes, *i.e.* cleaning of the mesh 23 and/or removal of settled out matter SP.

Referring now to Figure 2, there is shown water cleaning and storage apparatus 100 comprising a water storage tank 101 having a side wall 102 and a sloping top wall 103, the side wall 102 has a wall extension 104 which extends beyond the top wall 103 to provide a water settling volume 105.

20

Extending over the wall extension 104 and firmly secured thereto is a mesh 120 with a mesh hole size of approximately 5 mm.

25

Provided within the apparatus 100 is a slidably movable weir 106, the weir 106 being mechanically raisable and lowerable as indicated by arrow A to allow the volume of water capable of being held within the water settling volume 105 to be altered.

30 Located within the wall extension 104 is a valved opening 130.

In use, water flowing either from a down pipe DP or directly impinging the apparatus 100 will flow into the water settling volume 105 via the mesh 120, where significant solid particles will be removed.

The filtered water will remain in the water settling volume 105 for a period of time depending at least in part on the amount of water being captured and the height of the weir 106. The period of time will be selected to allow for settling out of most entrained particles.

Cleaned water will then overflow the weir 106 and flow into the storage tank 101. A typical water flow path is indicated by arrow W. The storage tank 101 will typically be located below ground level and will be permanently plumbed into a water supply system (which may include downstream water purification means or the tank may comprise *in situ* chemicals or other well-known purification systems).

To clean the apparatus 100, the valved opening 130 may be opened to allow the settled particles to flow out of the water settling volume 105. When doing so it is usual for the weir 106 to be lowered to ensure that the volume of retained water is relatively small, but large enough to ensure the settled particles SP are sufficiently fluid to be able to flow out of the valve opening 130.

The mesh 120 may be swept by a person walking thereon and sweeping with a brush or automatically swept by rotating arms (not shown).

The water cleaning apparatus 1 (as shown in Figure 1) and cleaning and storage apparatus 100 (Figure 2) are shown as being circular in plan. Whilst this is advantageous from a manufacturing point of view, the invention is not restricted to such circular forms and square, rectangle and other shapes may also be employed.

Also, each weir (14, 106) is shown as being centrally located. Whilst this is advantageous from a manufacturing point of view it is not necessary in all embodiments. The skilled person will know that variations can be made, according to installation and use requirements.

The downpipe DP need not be connected to roof guttering. It may also be connected to a waste water supply, for example the drain from a washing machine or other appliance or the outflow from an industrial process.

Claims

1. Apparatus for cleaning water, the apparatus comprising a holding tank with a central aperture through which extends an upstanding pipe, the uppermost edge of which providing a weir, the holding tank having a filter material provided across its top.
5
2. Water cleaning and storage apparatus, the apparatus comprising a water storage tank having a top wall through which a pipe extends, one end of the pipe providing a weir, a peripheral wall upstands from the storage tank to provide a holding tank and wherein a filter material is secured over and between the peripheral wall.
10
3. Apparatus according to Claim 1 or 2, comprising a wall sloping from or to the pipe.
15
4. Apparatus according to any preceding Claim, wherein the filter material is a mesh, typically fabricated from steel or other metal material having a mesh hole size of from 1 to 10 mm.
20

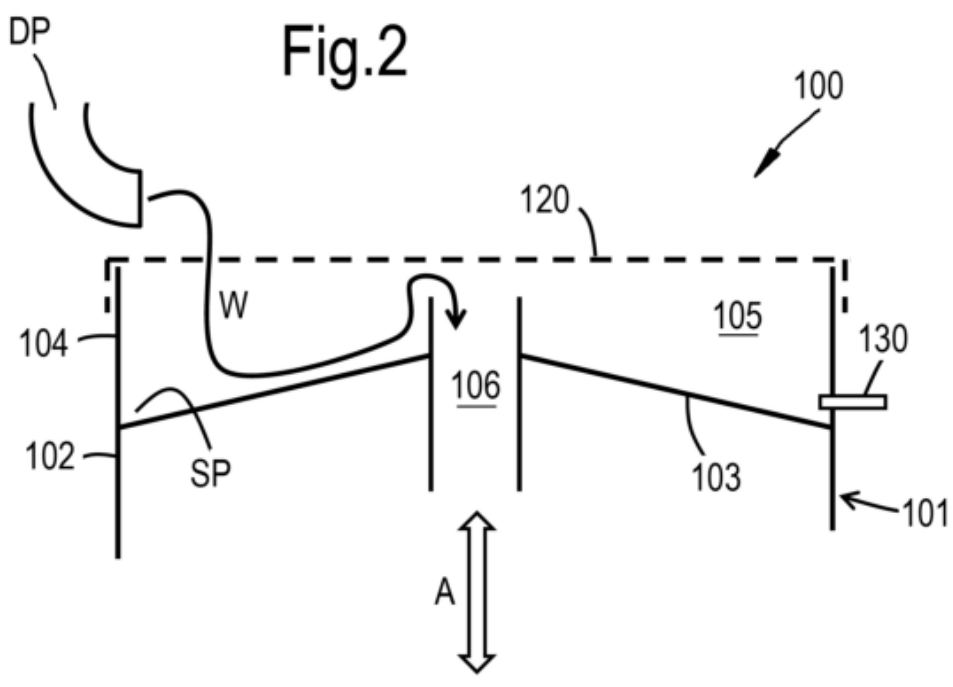
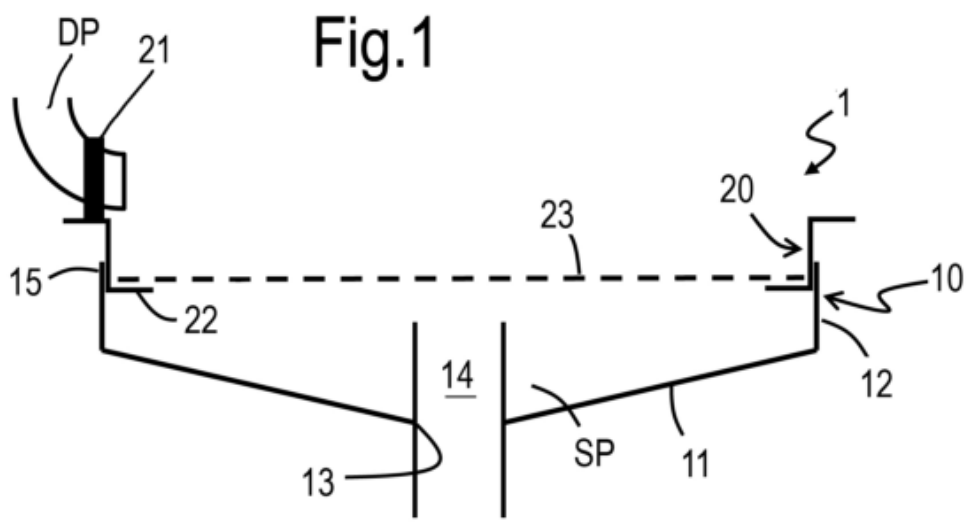

Wasteaway Technical Flyer

Water scarcity is becoming an ever more important issue as high temperatures in the summer months and disruption to rain-fall patterns looks set to increase. As such, people are looking to increase water harvesting in both the domestic and business setting. To meet this need we are the exclusive importers of the new “CleaniO” system. Our aim is for every home to have one – we are well on our way to doing so.

Figures A and B show the CleaniO system in schematic sectional views.

The system 1 is for use with a domestic cylindrical water butt B to aid in the cleaning of the water as it flows into the butt B.

The system 1 (as shown in Figure A) comprises a circular wall 2 which has two vertically separated flexible surfaces 3, 4 attached to the inner surface of the wall 2. The lowermost flexible surface 3 slopes downwardly from the circular wall 2 to a central pipe 5, which extends through the surface 3. The lowermost flexible surface 3 is securely attached to the central pipe 5.

The pipe 5 is provided with a filter F.

The uppermost flexible surface 4 also slopes downwardly from an upper portion of the circular wall 2. Extending through, and joined to, the uppermost flexible surface 4 is an elongate rod 6, having an upper end 6A and a lower end 6B. The rod is secured to the uppermost flexible surface 4 at join 7.

At the lower end 6B of the rod 6 there is provided plural cords 8 through which the rod 6 is secured to the pipe 5. At the upper end 6A of the rod 6 is a grasping handle H.

The circular wall 2 has an aperture 9 just above the point at which the lowermost flexible surface 3 attaches to the circular wall 2.

The uppermost flexible surface 4 is made from a plastics mesh material, the lowermost flexible surface 3 is made from an impermeable plastics sheet material, such as polyethylene.

To use, simply remove the lid from your butt and replace it with the CleaniO system 1.

Water will flow into the CleaniO system 1 either from a gutter or other pipe and will be filtered by the plastics mesh of the uppermost flexible surface 4.

- 5 The filtered water will be held on the impermeable lowermost flexible surface 3 until sufficient water builds up to overflow into the butt B via the pipe 5 and through the filter F. Other matter may settle out of the water held on the lowermost flexible surface 3.

When the system 1 requires cleaning, the handle H is grasped and pulled upwardly, 10 thereby pulling upwardly the rod 6 and hence the uppermost 4 and lowermost 3 flexible surfaces. With the rod 6 displaced upwardly the surfaces 3, 4 will slope downwardly towards the circular wall 2 (see Figure B). Any matter held on the lowermost surface 3 will flow out of the aperture 9 and leaves or other filtered material can be removed, e.g. brushed or washed, from the uppermost flexible 15 surface 4.

This is a cheap and easy solution for the provision of relatively clean water which would otherwise go to waste.

Early in 2014 we shall be importing a commercial version, the CleaniPro, able to hold in excess of 1000 litres on the lowermost flexible surface and having an integral 20 lower tank for storage of cleaned water. In the CleaniPro the raising and lowering of the rod 6 will be done automatically by a mechanical actuator and the aperture 9 will be opened and closed with the raising and lowering of the rod. In the CleaniPro the lowermost surface 3 will be made from extremely heavy duty plastics and the uppermost surface 4 will be made using our patented flexible steel mesh, which has 25 an effective pore size of less than 1 mm but an extremely high flow through rate. The uppermost surface 4 will be periodically swept by a pair of downwardly extending rotating arms which describe a conical sweeping action. We intend to provide the CleaniPro with optional UV or chemical sterilisation equipment to kill bacteria in the water held in the lower tank. We are ready to take orders now.

30

Fig.A

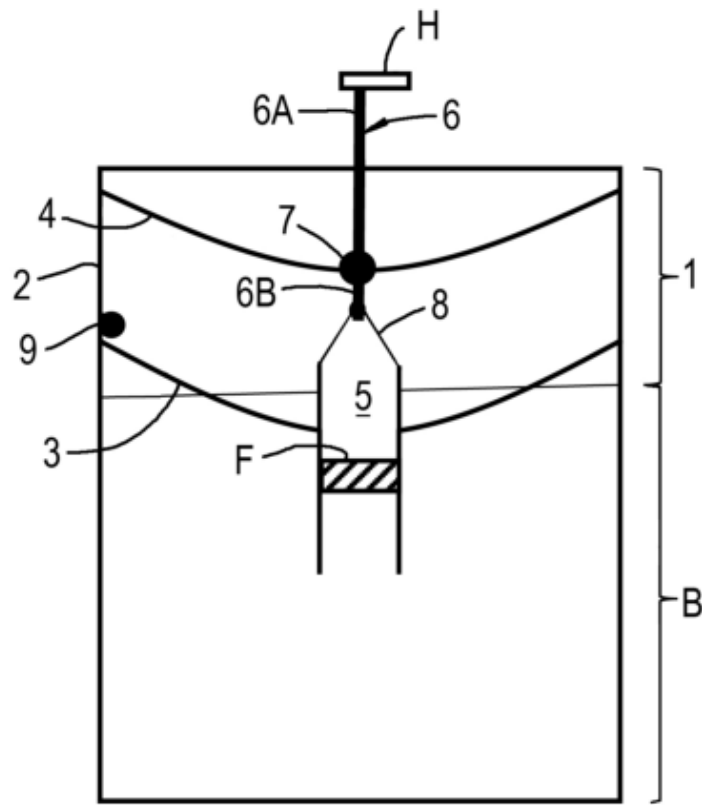
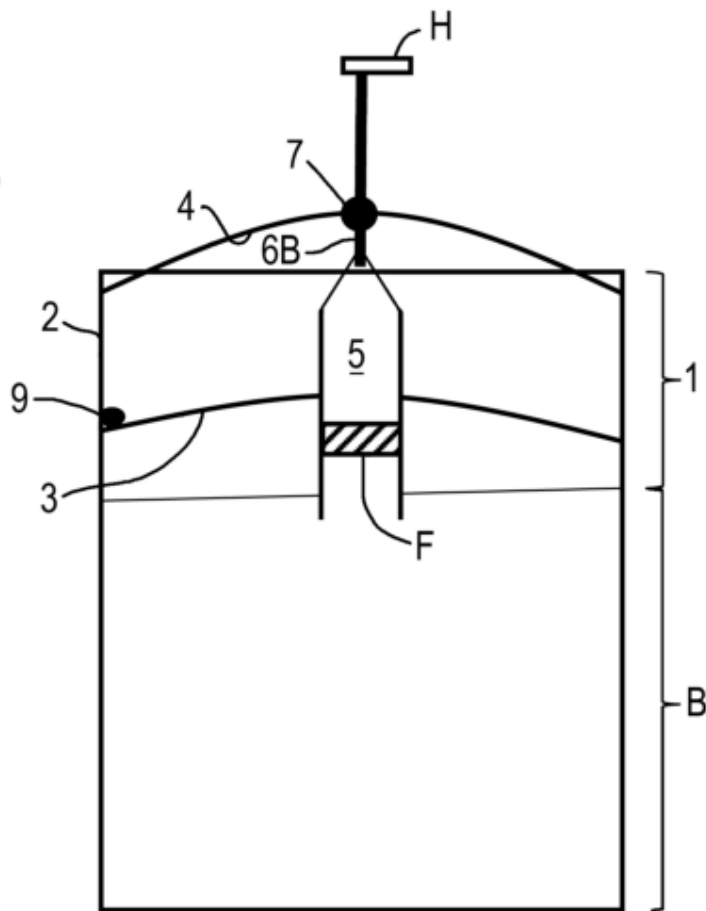

Fig.B



US 5555555

(Filed January 2003, Granted 01 December 2007)

5

WASTE DISPOSAL SYSTEM

This invention relates to a waste disposal system, specifically a waste water system of reduced size, as compared to the prior art.

10 It is known to filter water to remove entrained matter. It is also known to use large tanks, so called settling tanks, to allow water to stand for a period of time to encourage entrained matter to settle from the water. It is further known to use chemical flocculants to increase the removal of entrained matter from settling tanks.

15 In known industrial water cleaning processes the plant typically comprises a series of processing plants: a filter plant, a settling tank and downstream purification plant, each connected by pipework. Clearly such systems are not space efficient and do not lend themselves to miniaturisation for small commercial, or perhaps domestic use.

20 It is an object of the current invention to combine the known water cleaning plant to allow for miniaturisation. In this way further capacity can be added by adding a new inventive apparatus, thereby processing water in plural parallel cleaners.

25 In order to explain the invention, it shall now be described, by way of example only, with reference to the accompanying drawings.

Figure 1 is a schematic sectional view through a first apparatus according to the invention;

Figure 2 is a schematic sectional view through a second apparatus according to the invention;

5 Figure 2A is a sectional view along line A-A of Figure 2.

Referring to Figure 1, there is shown apparatus for cleaning water 1 comprising a tubular tank 10 for holding water to be cleaned, an inlet pipe 11 for supplying water to be cleaned and an outlet pipe 12 to deliver cleaned water. The inlet pipe 11
10 provides dirty water to the top of the tank 10.

Spanning the tank 10 is a funnel portion 15 with a downwardly inclined conical wall 17. The funnel portion 15 has, at its center, a tube portion 18. Provided on the conical wall 17 are a series of baffles, first baffle 19a, second baffle 19b to arrest
15 direct flow of the flowing water in to the tube portion 18. The baffles 19a, 19b are circular, when looked at in plan. Most conveniently, the second baffle 19b is formed as an extension to the tube portion 18, although the second baffle 19b may be located away from the edge of the tube portion 18.

20 Located within the tube portion 18 is a filter 16, typically comprising a relatively fine filter medium. The filter 16 separates the main portion of the tank into an upper portion UP and a lower portion LP. The filter 16 can be formed from a plastics material, preferably a mass of plastics fibres.

25 A circular weir 20 is provided within the tank 10 and defines an outer tank portion 21. The outlet pipe 12 extends from a lowermost portion of the outer wall of the tank 10 to communicate with the outer tank portion 21.

Extending from the central part of the tank 10 is a sludge removal tube 30

5 In use, water to be cleaned is pumped to the tank 10 via inlet pipe 11 and impinges on the conical wall 17. The baffles 19a, 19b ensure that the water cannot run directly onto the filter 16 which removes fine particles from the water. After entering the upper portion UP the water will be forced to run over the baffles 19a, 19b in sequence. The water then runs into the main body of the tank 10 where it starts to fill the tank 10.

10 Once the tank 10 is full, water overflows the weir 20 and fills the peripheral volume 21. Once the peripheral tank is filled to a pre-determined level a valve in the outlet pipe 12 is opened to reduce the volume of water in the peripheral volume 21. The sludge removal tube 30 is periodically actuated to remove any collected solid material from the tank 10.

15

The relatively fine filter 16 provides a restriction to the flow of water entering the lower portion LP. The restriction causes water to back up into the upper portion UP, thereby ensuring entrained particles settle on top of the filter 16. The settled particles form a cake to increase the filter capacity of the filter 16.

20

To improve the settling capacity of material within the lower portion LP of the tank 10 flocculants can be added to the water held in the tank 10.

25 To clean the filter 16 the lid 30 is removed and the filter 16 lifted out to remove any retained material by washing or physical removal.

Accordingly, the first embodiment provides a more space efficient water processing apparatus.

Referring to Figure 2 and Figure 2A there is shown a second apparatus 100 with the same or similar integers as are found in the Figure 1 embodiment are indicated with the same numeral, differentiated by a prime ('). In this embodiment the tank 10' is rectangular (e.g. square), although it could be another shape, such as circular.

5 The first baffle 19a' extends linearly across the upper portion UP'. The second baffle 19b' is circular in plan.

In addition to those components similar or identical to the first embodiment, the upper portion UP' also has a relatively coarse filter CF to remove relatively large

10 particles. The coarse filter CF is well known in the art of water cleaning and comprises a metal frame which sits in the top of the tank 10' on a ledge. The use of such coarse filters CF is advantageous because it removes large particles and allows a finer cake to develop on the filter 16'.

15 The lower portion LP' of the tank 10' is separated by a wall 101 which provides the weir 20'. The wall 101 extends across the tank 10', one side of which 101a is opaque the other side of which 101b is transparent to ultra violet (UV) light. Located between the first 101a and second sides 101b are one or more UV lights 102 which are energised continuously or periodically. Preferably the lights 102 are energised only

20 when water is being supplied over the weir 20' and/or when the outlet pipe 12' is closed.

In use, cleaned water overflows wall 101 and is irradiated by the UV light from the lights 102. The UV radiation sterilises water held in the outer tank 103. Thus the

25 second embodiment provides fully potable water at the outlet pipe 12'.

[Claims Omitted]

Fig.1

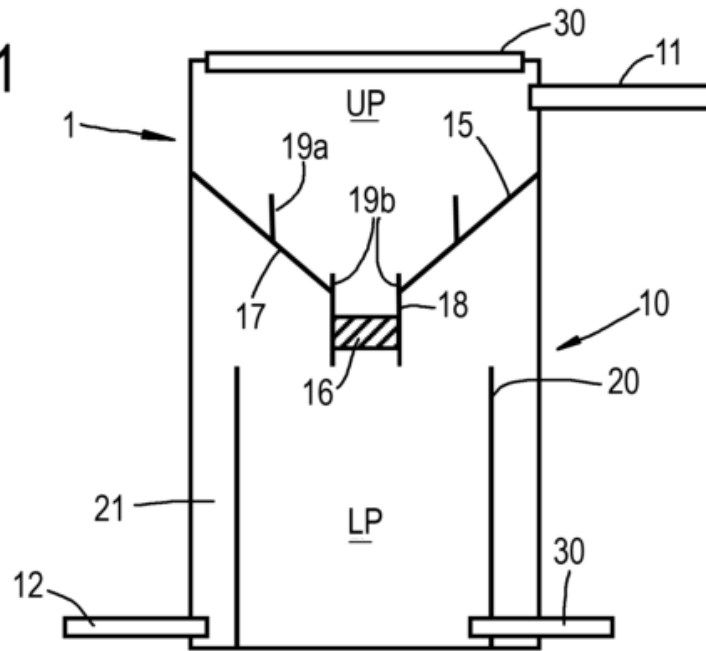

Fig.2

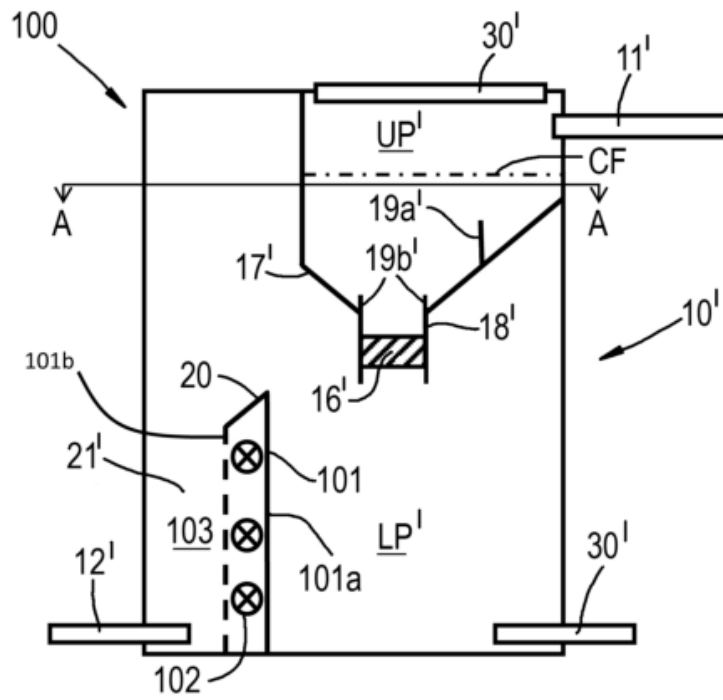

Fig.2A

