

THE JOINT EXAMINATION BOARD

PAPER P3 – Preparation of Specifications for United Kingdom Patents

Thursday 10th OCTOBER 2013

10.00 a.m. – 2.00 p.m.

Please read the following instructions carefully. **Time Allowed – FOUR HOURS**

1. The whole question is to be attempted.
2. Marks to be awarded are given at the end of the question.
3. Please note the following:
 - a. Enter the Paper Number (P3) and your Examination number in the appropriate boxes at the top of each sheet of paper;
 - b. The scripts are photocopied for marking purposes. Please write with a **dark inked pen** on one side of the paper only and within the printed margins, and do not use highlighters in your answer;
 - c. Do not state your name anywhere in the answer;
 - d. Write clearly, examiners cannot award marks to scripts that cannot be read;
 - e. You must number all the pages of your answer script. Once the exam finishes, an **additional** 5 minutes will be allowed for you to do this.
4. Under the Examination Regulations **you may be disqualified from the examination and have other disciplinary measures taken against you if:**
 - a. you are found with unauthorised printed matter or other unauthorised material in the examination room;
 - b. your mobile phone is found to be switched on;
 - c. you copy the work of another candidate, use an electronic aid, or communicate with another candidate or with anyone outside the examination;
 - d. you continue to write after being told to stop writing by the invigilator(s). **NO WRITING OF ANY KIND IS PERMITTED AFTER THE TIME ALLOTTED TO THIS PAPER HAS EXPIRED.**
5. **At the end of the examination assemble your answer sheets in order and put them in the WHITE envelope provided.** Do not staple or join your answer sheets together in any way. Any answer script taken out of the examination room will not be marked.
6. This paper consists of 11 pages, including this page, and comprises 2 pages of the question, 4 pages of client's drawings and a further set of the drawings for use in your answer.

In this question you are asked to draft a specification for filing at the UK Intellectual Property Office with a view to obtaining a UK patent. You should assume that the client's description of the prior art in the field is complete. You should not take into account any other prior art in the field which might be known to you. You should also assume that the client's description of the device and its operation is accurate, i.e. that the device works as described. The allocation of marks is given at the end of the question.

Hi Pat

I'm sure you have fitted a few electrical sockets in your time, though I guess you need to be a bit more careful what you do these days because of the safety regulations. Anyway, my latest idea is directed at the professional electrician, though the occasional D.I.Y. person will find it useful and probably pay a lot more for it.

We install electrical wiring in newly built houses in two stages. Once the basic structure, walls, ceilings, is in place, the electrician fits conduit for the wiring and back boxes for receiving the electrical sockets and light switches, etc. This is called the first fit. It is a lot easier for the electrician to run his wiring through the conduit at this stage and leave the ends coiled up in the back boxes. The plasterer then plasters the walls and will cover the conduit and finish the plaster just proud of the front edge of the back boxes.

The trouble is that the plasterer is in a hurry and so often ends up leaving quite a lot of plaster in the back boxes – which he doesn't bother to clean out. To be fair, it is quite difficult to form a clean edge at the front of the back box – as I expect you have found. The electrician, of course, then has to dig out the dried plaster in order to get to his wires and fit the sockets, switches etc. to the back boxes (this is the second fit). If he is not careful, he can damage the wires, and he gets upset because of the time being wasted. Some electricians don't fit the wiring until after the plasterer has done his bit. Which is fine, but can be a bit trickier to do and it is still necessary to clean out the boxes and he is likely to damage the plaster when he runs his wiring. So, either way, I end up having to make peace between the electrician and the plasterer.

Anyway, to cut a long story short, I have designed a shield which will sit tightly inside the back box to keep the plaster out. The plasterer can plaster up against the shield wall, so he gets a better finish as well. Once the plaster is dried, the electrician pulls out the shield and fits his sockets. So it saves time for everyone. I will make the shield of cardboard, so it is disposable, but will use plastic for the D.I.Y. market. After the electrician has done his first fit, he, or the plasterer, fits the shields into the back boxes.

I'm quite excited by this idea and will be talking to one of the big house builders tonight to see if I can get them to specify that their electricians and plasterers must use my shields.

Please file a UK patent application today. I've attached some drawings to get you started.

Thanks

Jo

P.S. I should have mentioned that there was a product on the market many years ago called Protectabox (I've enclosed a leaflet I still have). It wasn't a success because the side walls and flanges were too flimsy – it fell out of the back box as soon as the plasterer brushed against it and he wouldn't bother to put it back or hold it firm with his free hand. Still, it would be worthwhile covering the old product if you can. It was made of plastic and was quite bulky, whereas mine can be folded flat across a diagonal if I make it of cardboard or thin plastic. My stabiliser pushes the shield walls out tight against the back box to hold it in place and stop the walls caving in when the plasterer plasters up against them. I have added some screw holes so the shield can be screwed to the back box if the shield is a loose fit in the box (the boxes can get out of shape when they are being fitted), but I still use the stabiliser to reinforce the shield walls. The stabiliser means I can make my walls more flexible, so the electrician can squeeze them in to slide the legs into the back box. You get different depths of back box, but the legs can be cut short if need be, and, of course, some boxes are square to take a single socket or switch.

Thanks again
Jo.

Marks will be allocated as follows:

INTRODUCTION AND DESCRIPTION	35 MARKS
CLAIMS	60 MARKS
ABSTRACT	5 MARKS

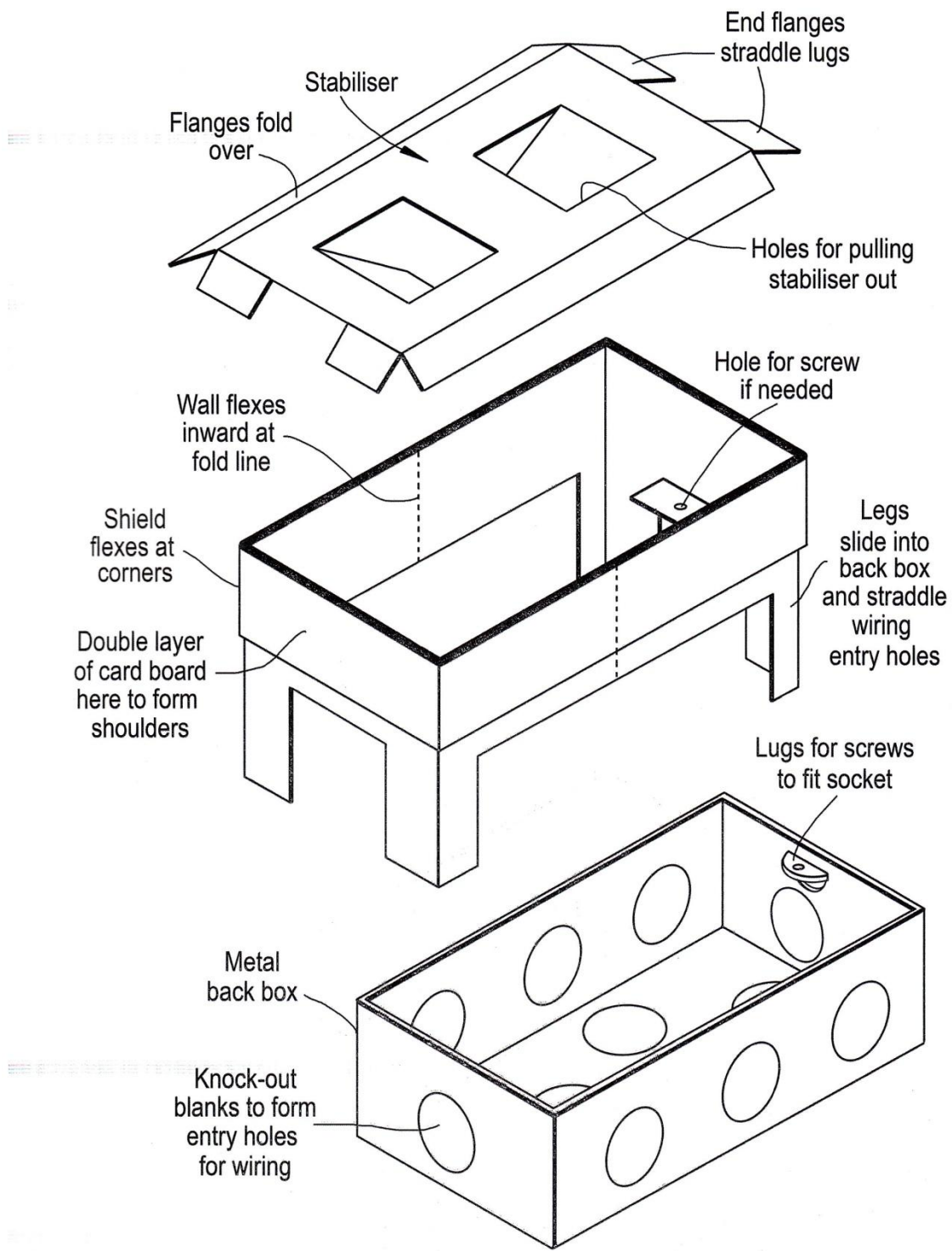

Squeeze sides together and fit in back box

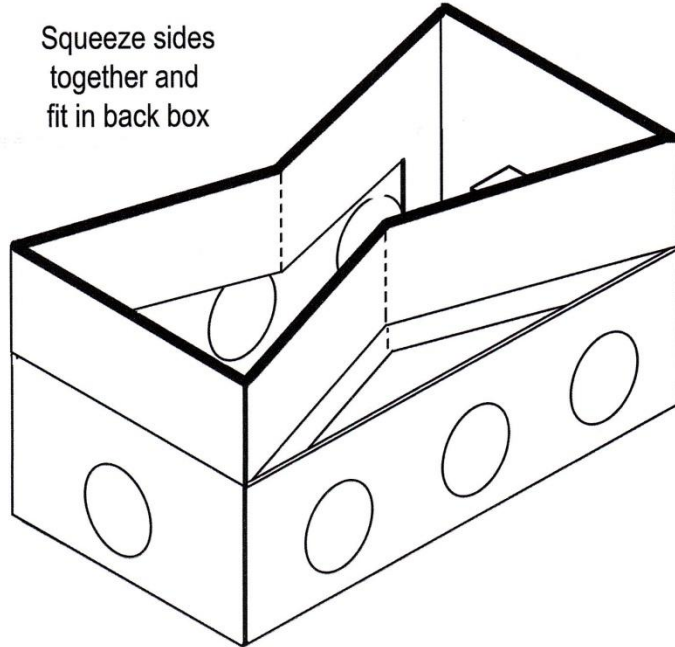

Push stabiliser in to push shield walls out against back box

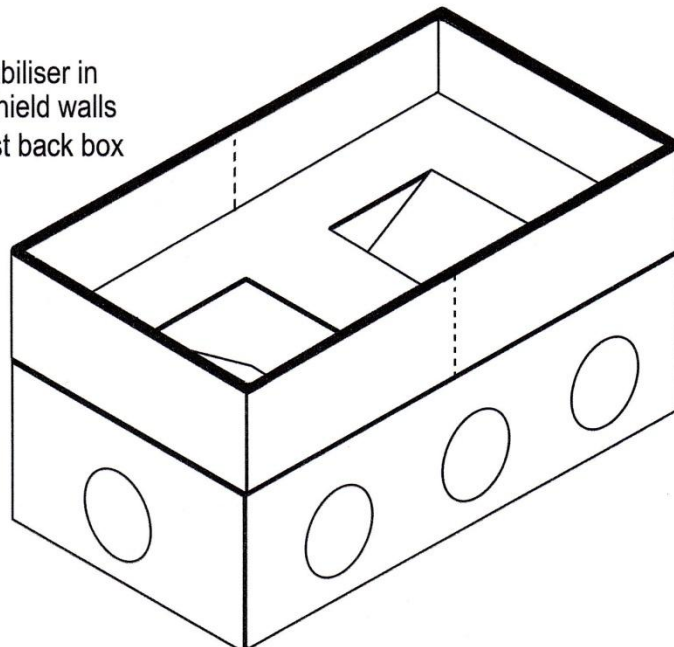

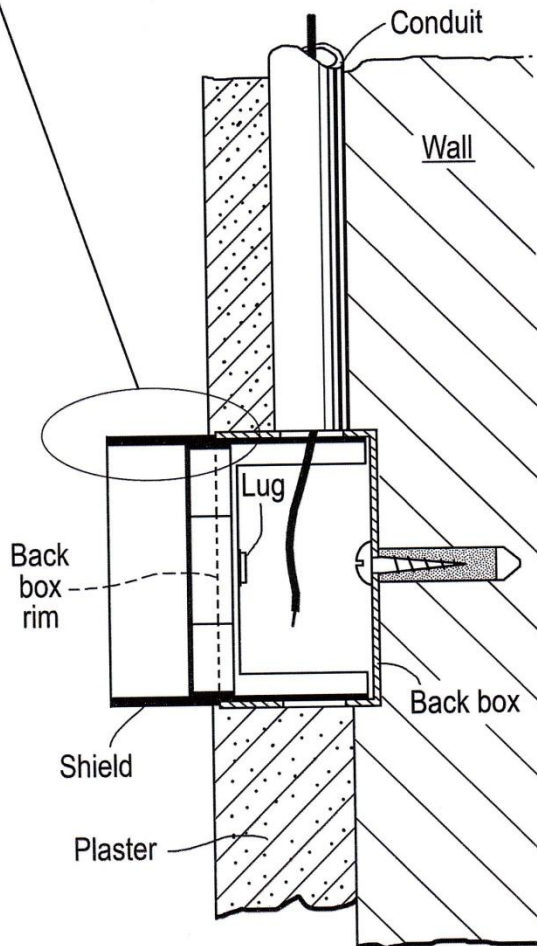
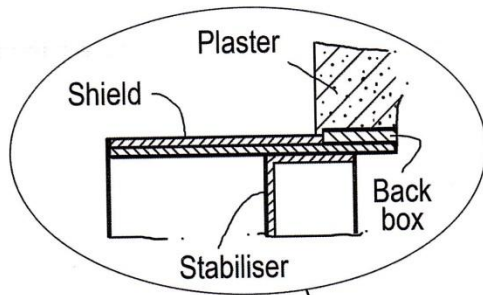

PROTECTABOX

A temporary plastic shield for protecting an electrical back box from ingress of building material, such as plaster, during building work. The shield comprises a frame member which in use provides an extension to the side wall or walls of the box and resilient flanges for retaining the frame member in the box. During use, the back box is mounted in the wall, the shield is attached, the surrounding wall is plastered finally the shield is removed

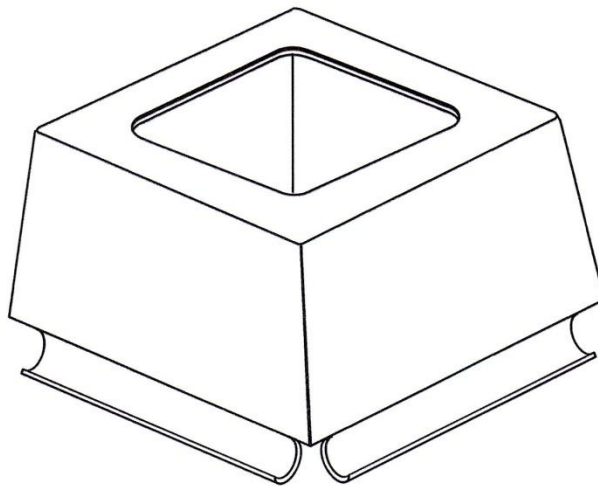

PAPER QUESTION

--	--

SHEET OF-

--	--

CANDIDATE
NUMBER

--

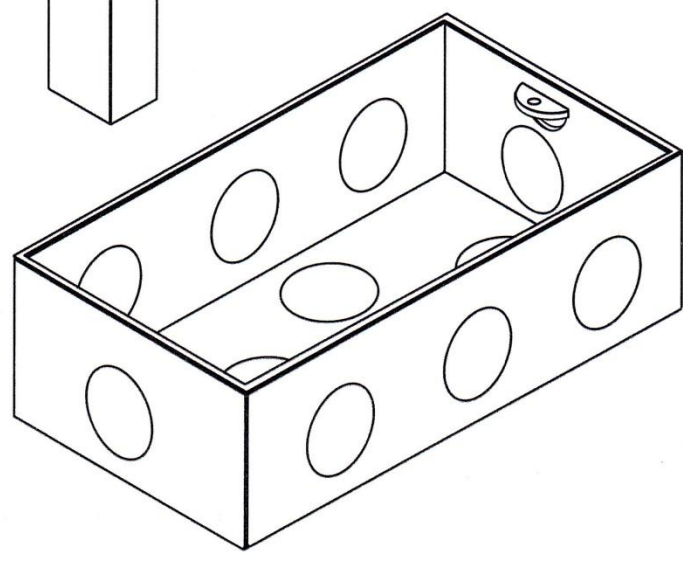
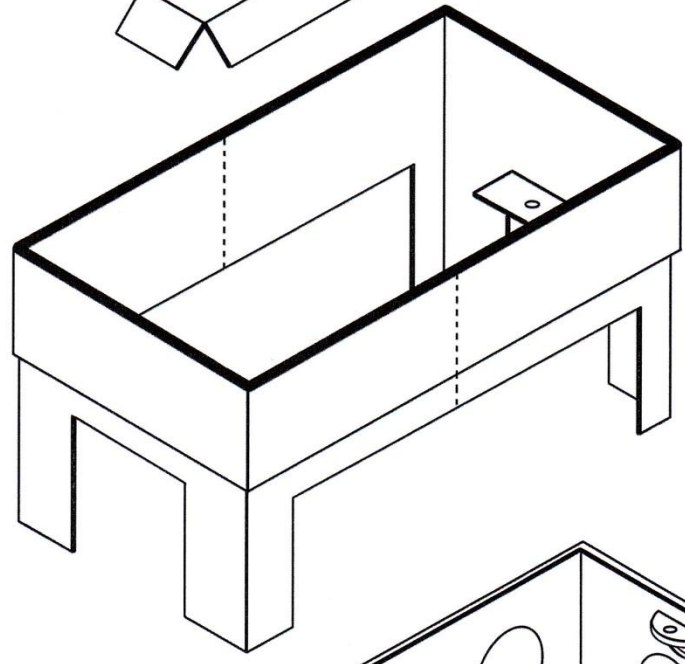
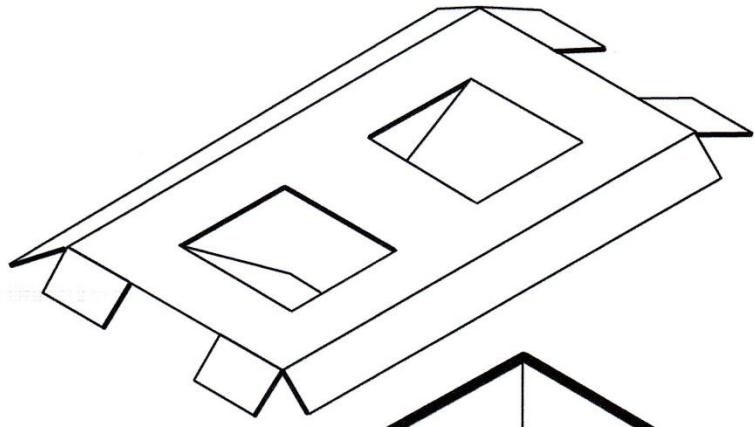

PAPER QUESTION

--	--

SHEET OF-

--	--

CANDIDATE

--

NUMBER

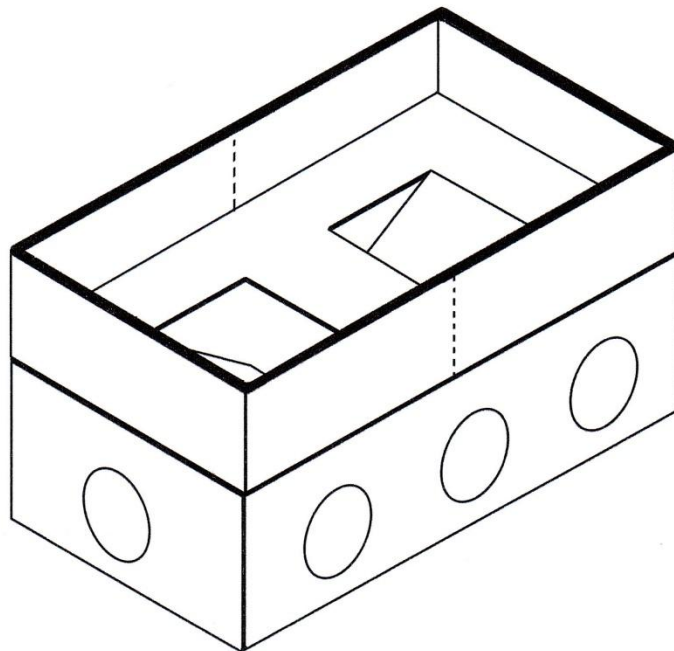
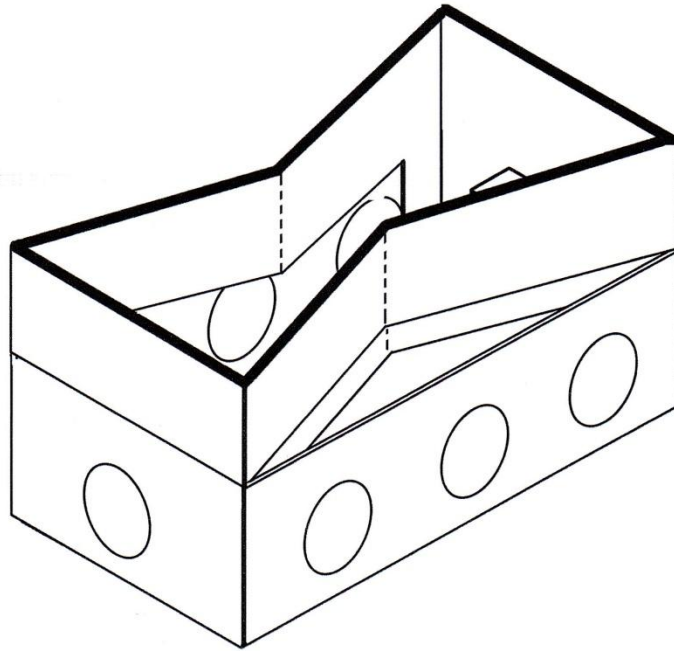

PAPER QUESTION

--	--

SHEET OF-

--	--

CANDIDATE

--

NUMBER

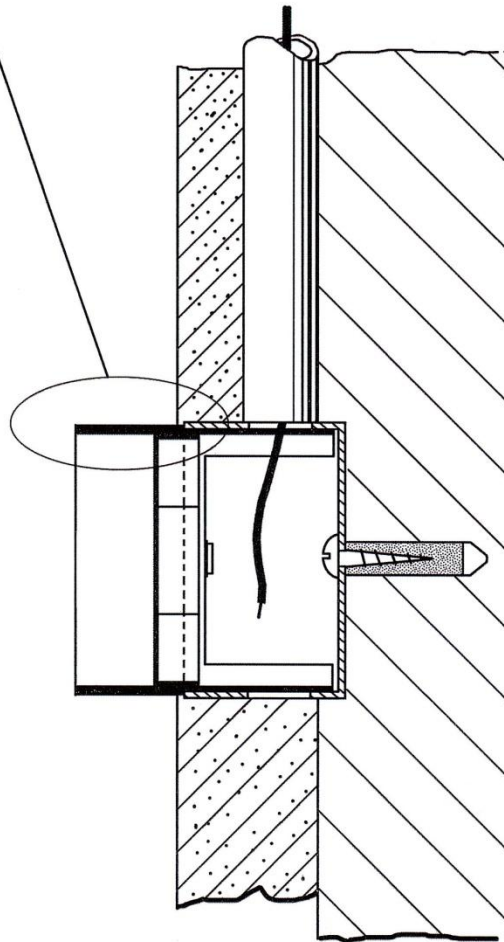
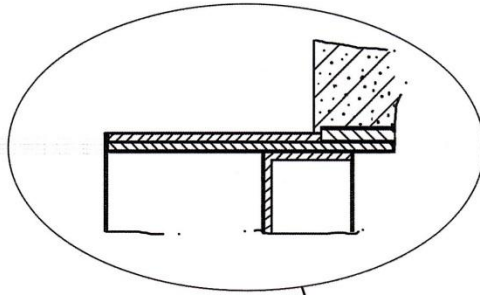

PAPER QUESTION

--	--

SHEET OF-

--	--

CANDIDATE

--

NUMBER

