

C

2009 - PH

Test Paper Code : PH

Time : 3 Hours Maximum Marks : 300

INSTRUCTIONS

- The question-cum-answer booklet has 32 pages and has 25 questions. Please ensure that the copy of the question-cum-answer booklet you have received contains all the questions.
- Write your **Roll Number, Name and the name of the Test Centre** in the appropriate space provided on the right side.
- Write the answers to the objective questions against each Question No. in the **Answer Table for Objective Questions**, provided on Page No. 9. Do not write anything else on this page.
- Each objective question has 4 choices for its answer: (A), (B), (C) and (D). Only **ONE** of them is the correct answer. There will be **negative marking** for wrong answers to objective questions. The following marking scheme for objective questions shall be used :
 - For each correct answer, you will be awarded **6 (six)** marks.
 - For each wrong answer, you will be awarded **-2 (Negative two)** marks.
 - Multiple answers to a question will be treated as a wrong answer.
 - For each un-attempted question, you will be awarded **0 (Zero)** mark.
- Answer the subjective question only in the space provided after each question.
- Do not write more than one answer for the same question. In case you attempt a subjective question more than once, please cancel the answer(s) you consider wrong. Otherwise, the answer appearing last only will be evaluated.
- All answers must be written in blue/black/blue-black ink only. Sketch pen, pencil or ink of any other colour should not be used.
- All rough work should be done in the space provided and scored out finally.
- No supplementary sheets will be provided to the candidates.
- Clip board, log tables, slide rule, calculator, cellular phone, pager and electronic gadgets in any form are NOT allowed.**
- The question-cum-answer booklet must be returned in its entirety to the Invigilator before leaving the examination hall. Do not remove any page from this booklet.

Somesh

Somesh

StudentBounty.com

C

READ INSTRUCTIONS ON THE SIDE OF THIS PAGE CAREFULLY

| ROLL NUMBER | | | | | |
|---------------|--|--|--|--|--|
| | | | | | |
| Name : | | | | | |
| | | | | | |
| Test Centre : | | | | | |
| | | | | | |

Do not write your Roll Number or Name anywhere else in this question-cum-answer booklet.

I have read all the instructions and shall abide by them.

.....

Signature of the Candidate

I have verified the information filled by the Candidate above.

.....

Signature of the Invigilator

Special Instructions / Useful Data

Divergence of a vector \vec{V} in spherical coordinates:

$$\vec{\nabla} \cdot \vec{V} = \frac{1}{r^2} \frac{\partial}{\partial r} (r^2 V_r) + \frac{1}{r \sin \theta} \frac{\partial}{\partial \theta} (\sin \theta V_\theta) + \frac{1}{r \sin \theta} \frac{\partial V_\phi}{\partial \phi}$$

DO NOT WRITE ON THIS PAGE

IMPORTANT NOTE FOR CANDIDATES

- Attempt **ALL** the 25 questions.
- Questions 1-15 (objective questions) carry **six** marks each and questions 16-25 (subjective questions) carry **twenty one** marks each.
- Write the answers to the objective questions in the **Answer Table for Objective Questions** provided on page 9 only.

Q.1 Isothermal compressibility κ_T of a substance is defined as $\kappa_T = -\frac{1}{V} \left(\frac{\partial V}{\partial P} \right)_T$. Its value for n moles of an ideal gas will be

- (A) $\frac{1}{P}$ (B) $\frac{n}{P}$ (C) $-\frac{1}{P}$ (D) $-\frac{n}{P}$

Q.2 A space crew has a life support system that can last only for 1000 hours. What minimum speed would be required for safe travel of the crew between two space stations separated by a fixed distance of 1.08×10^{12} km?

- (A) $\frac{c}{\sqrt{3}}$ (B) $\frac{c}{\sqrt{2}}$ (C) $\frac{c}{2}$ (D) $\frac{c}{\sqrt{5}}$

Q.3 An oscillating voltage $V(t) = V_0 \cos \omega t$ is applied across a parallel plate capacitor having a plate separation d . The displacement current density through the capacitor is

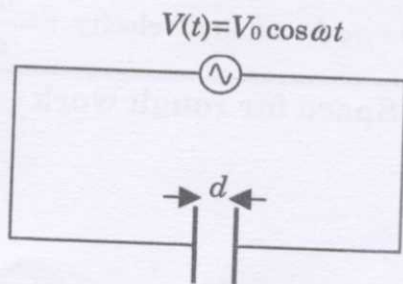

- (A) $\frac{\epsilon_0 \omega V_0 \cos \omega t}{d}$ (B) $\frac{\epsilon_0 \mu_0 \omega V_0 \cos \omega t}{d}$
- (C) $-\frac{\epsilon_0 \mu_0 \omega V_0 \sin \omega t}{d}$ (D) $-\frac{\epsilon_0 \omega V_0 \sin \omega t}{d}$

- Q.4 Two spherical nuclei have mass numbers 216 and 64 with their radii R_1 and R_2 respectively. The ratio $\frac{R_1}{R_2}$ is
- (A) 1.0 (B) 1.5 (C) 2.0 (D) 2.5

- Q.5 In the Fourier series of the periodic function (shown in the figure)

$$f(x) = |\sin x|$$

$$= \sum_{n=0}^{\infty} [\alpha_n \cos nx + \beta_n \sin nx]$$

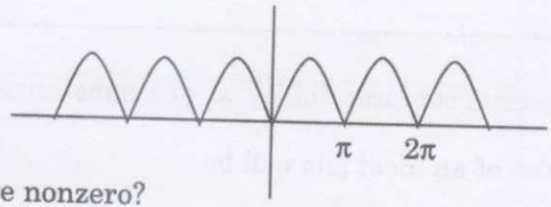

which of the following coefficients are nonzero?

- (A) α_n for odd n (B) α_n for even n
 (C) β_n for odd n (D) β_n for even n
- Q.6 A particle is moving in space with O as the origin. Some possible expressions for its position, velocity and acceleration in cylindrical coordinates (ρ, ϕ, z) are given below. Which one of these is correct?

- (A) position vector $\vec{r} = \rho \hat{\rho} + \rho \phi \hat{\phi} + z \hat{z}$ and velocity $\vec{v} = \frac{d\rho}{dt} \hat{\rho} + \rho \frac{d\phi}{dt} \hat{\phi} + \frac{dz}{dt} \hat{z}$
- (B) velocity $\vec{v} = \frac{d\rho}{dt} \hat{\rho} + \rho \frac{d\phi}{dt} \hat{\phi} + \frac{dz}{dt} \hat{z}$ and acceleration $\vec{a} = \frac{d^2\rho}{dt^2} \hat{\rho} + \frac{d}{dt} \left(\rho \frac{d\phi}{dt} \hat{\phi} \right) + \frac{d^2z}{dt^2} \hat{z}$
- (C) position vector $\vec{r} = \rho \hat{\rho} + z \hat{z}$ and velocity $\vec{v} = \frac{d\rho}{dt} \hat{\rho} + \rho \frac{d\phi}{dt} \hat{\phi} + \frac{dz}{dt} \hat{z}$
- (D) position vector $\vec{r} = \rho \hat{\rho} + \rho \phi \hat{\phi} + z \hat{z}$ and velocity $\vec{v} = \frac{d\rho}{dt} \hat{\rho} + \frac{d}{dt} (\rho \phi \hat{\phi}) + \frac{dz}{dt} \hat{z}$

Space for rough work

Q.7 Which one of the following is an INCORRECT Boolean expression?

- (A) $\overline{P}Q + PQ = Q$
- (B) $(P + \overline{Q})(P + Q) = P$
- (C) $P(P + Q) = Q$
- (D) $(\overline{P}\overline{Q}\overline{R} + \overline{P}\overline{Q}R + P\overline{Q}\overline{R} + P\overline{Q}R) = \overline{Q}$

Q.8 Monochromatic X-rays of wavelength 1 \AA are incident on a simple cubic crystal. The first order Bragg reflection from (311) plane occurs at an angle of 30° from the plane. The lattice parameter of the crystal in \AA is

- (A) 1
- (B) $\sqrt{3}$
- (C) $\sqrt{\frac{11}{2}}$
- (D) $\sqrt{11}$

Q.9 An electric field $\vec{E}(\vec{r}) = \frac{1}{r}(\alpha\hat{r} + \beta\sin\theta\cos\phi\hat{\phi})$ exists in space. What will be the total charge enclosed in a sphere of unit radius centered at the origin?

- (A) $4\pi\epsilon_0\alpha$
- (B) $4\pi\epsilon_0(\alpha + \beta)$
- (C) $4\pi\epsilon_0(\alpha - \beta)$
- (D) $4\pi\epsilon_0\beta$

Space for rough work

Q.10 A thin massless rod of length $2l$ has equal point masses m attached (see figure). The rod is rotating about an axis passing through its centre and making an angle θ with it. The magnitude of the rate of change of its angular momentum $\left| \frac{d\vec{L}}{dt} \right|$ is

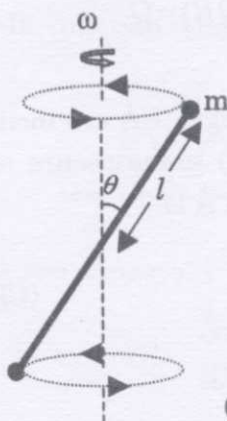

- (A) $2ml^2\omega^2 \sin \theta \cos \theta$ (B) $2ml^2\omega^2 \sin \theta$
 (C) $2ml^2\omega^2 \sin^2 \theta$ (D) $2ml^2\omega^2 \cos^2 \theta$

Q.11 A battery with a constant *emf* ϵ and internal resistance r_i provides power to an external circuit with a load resistance made up by combining resistances R_L and $2R_L$ in parallel. For what value of R_L will the power delivered to the load be maximum?

- (A) $R_L = \frac{r_i}{4}$ (B) $R_L = \frac{r_i}{2}$ (C) $R_L = \frac{2}{3}r_i$ (D) $R_L = \frac{3}{2}r_i$

Space for rough work

Q.14 A box containing 2 moles of a diatomic ideal gas at temperature T_0 and another identical box containing 2 moles of a monoatomic ideal gas at temperature T_0 . There are no thermal losses and the heat capacity of the boxes is negligible. Find the final temperature of the mixture of gases (ignore the vibrational degrees of freedom for the diatomic molecules).

- (A) T_0 (B) $1.5 T_0$ (C) $2.5 T_0$ (D) $3 T_0$

Q.15 Moment of inertia of a solid cylinder of mass m , height h and radius r about an axis (shown in the figure by dashed line) passing through its centre of mass and perpendicular to its symmetry axis is

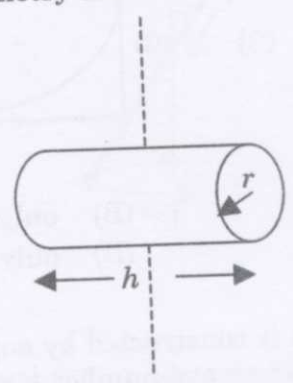

- (A) $\frac{1}{4}mr^2 + \frac{1}{12}mh^2$ (B) $\frac{1}{2}mr^2 + \frac{1}{8}mh^2$
(C) $\frac{1}{2}mr^2 + \frac{1}{12}mh^2$ (D) $\frac{1}{2}mr^2 + \frac{1}{4}mh^2$

Space for rough work

- Q.16 A parallel beam of light of diameter 1.8 cm contains two wavelengths 4999.7 Å and 5000.25 Å. The light is incident perpendicularly on a large diffraction grating with 5000 lines per centimeter.
- (a) Using Rayleigh criterion, find the least order at which the two wavelengths are resolved. (12)
- (b) What will be the angular separation (in radians) of the two wavelengths at order $n = 2$? (9)

- Q.17 A block of mass M is free to slide on a frictionless horizontal floor. The block has a cylindrical cavity of radius R in the middle of it. The centre of mass (CM) of the block is on the dashed line passing through the centre of the cavity (see figure). Initially the CM of the block is at a horizontal distance X_1 from the origin. Now a point particle of mass m is released from point A into the cavity. There is negligible friction between the particle and the cavity surface. When the particle reaches point B, the CM of the block is at a distance X_2 from the origin. Find $(X_2 - X_1)$. (21)

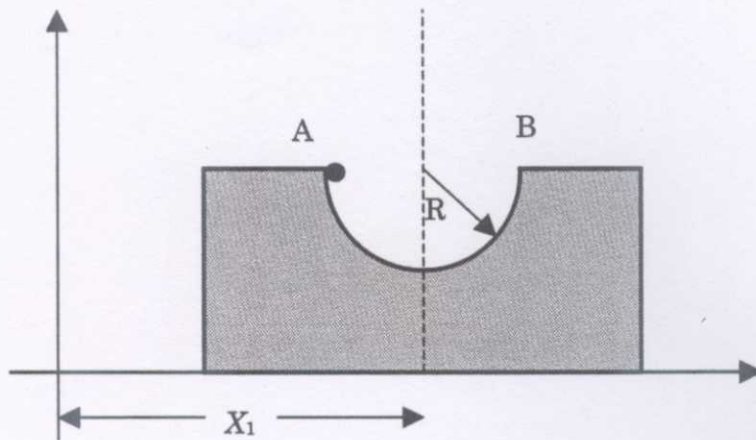

Q.18 The electric field of an electromagnetic wave propagating through vacuum is given by

$$\vec{E}(\vec{r}, t) = E_0 \hat{z} \cos(100\sqrt{3}\pi x - 100\pi y - \omega t).$$

- (a) What is the wave vector \vec{k} ? Hence find the value of ω . (9)
- (b) At the time $t = 0$ there is a point charge q with velocity $\vec{v} = v_0 \hat{x}$ at the origin. What is the instantaneous Lorentz force acting on the particle? (12)

- Q.19 Consider two infinitely long wires parallel to the z -axis carrying the same current. One wire passes through the point L with coordinates $(-1, 1)$ and the other through M with coordinates $(-1, -1)$ in the XY plane as shown in the figure. The direction of the current in both the wires is in the positive z -direction.

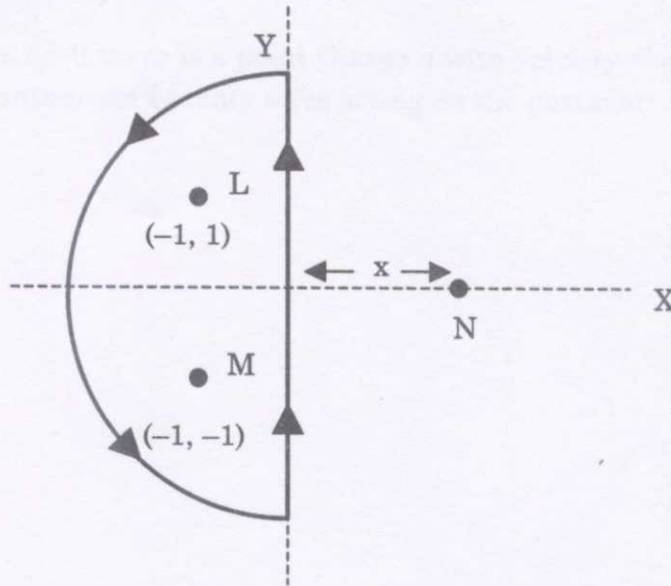

- (a) Find the value of $\oint \vec{B} \cdot d\vec{l}$ along the semicircular closed path of radius 2 units shown in the figure. (9)
- (b) A third long wire carrying current I and also perpendicular to the XY plane is placed at a point N with coordinates $(x, 0)$ so that the magnetic field at the origin is doubled. Find x and the direction of the current in the third wire. (12)

Q.20 A particle of mass m is confined in a one-dimensional box of unit length. At $t=0$ the wavefunction of the particle is $\Psi(x,0) = A \sin 2\pi x \cos \pi x$, where A is a normalization constant.

- (a) Write the wavefunction $\Psi(x, t)$ at a later time t .
- (b) Find the expectation values of momentum and energy at $t = 0$.

Q.21 For the transistor circuit shown in the figure $\beta_{dc} = 100$ and $V_{BE} = 0.7$ V. Determine the base current I_B , the collector-emitter voltage V_{CE} , the emitter voltage V_E , the voltage V_B and the saturation current I_{Csat} .

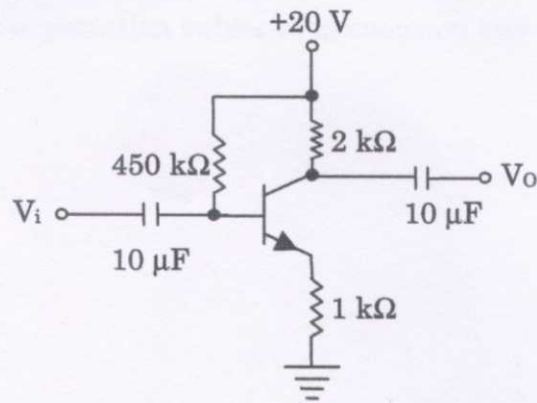

Q.22 The equation of state of one mole of a van der Waals gas is $\left(p + \frac{a}{V^2}\right)(V - b) = RT$ and its internal energy $U(T, V)$ is given by $U(T, V) = U_0 + C_V T - \frac{a}{V}$, where U_0 and C_V can be taken as constants.

- (a) Prove that in a reversible adiabatic process the temperature and volume satisfy the equation $T(V - b)^{\gamma} = \text{constant}$. (12)
- (b) Calculate the change in entropy of the gas when it undergoes a reversible isothermal expansion from volume V_0 to $2V_0$. (9)

- Q.23 (a) Find the normalized eigenvector α of the matrix $M = \begin{bmatrix} 0 & 1 \\ 1 & 0 \end{bmatrix}$, corresponding to the positive eigenvalue.
- (b) The normalized eigenvectors of the matrix $N = \begin{bmatrix} 0 & -i \\ i & 0 \end{bmatrix}$ are β_1 and β_2 with the eigenvalues λ_1 and λ_2 , respectively and $\lambda_1 > \lambda_2$. If the eigenvector α obtained in part (a) is expressed as $\alpha = P\beta_1 + Q\beta_2$, find the constants P and Q . (12)

3

Q.24 A particle of mass m is thrown vertically up from the ground with initial speed v_0 . As it moves it experiences a drag force $|F_{drag}| = kv^2$, where v is the speed of the particle and k is a constant. Up to what height does the particle go and what is its speed when it reaches the ground again? (21)

Q.25 Consider the radioactive transformation $A \rightarrow B \rightarrow C$ with decay constants λ_A and λ_B for elements A and B ; C is a stable element. Assume that at $t=0$, $N_A=N_0$, $N_B=0$ and $N_C=0$, where N_A , N_B and N_C are the number of atoms of A , B and C , respectively.

(a) Show that at any later time t the number of atoms N_B of element B will be

$$N_B(t) = \frac{N_0 \lambda_A}{\lambda_B - \lambda_A} [e^{-\lambda_A t} - e^{-\lambda_B t}]. \quad (12)$$

(b) Sketch qualitatively the variation of N_A , N_B and N_C with time on three separate plots. (9)