



**Coimisiún na Scrúduithe Stáit**  
**State Examinations Commission**

**Leaving Certificate 2016**

**Marking Scheme**

**Technology**

**Higher Level**

### **Note to teachers and students on the use of published marking schemes**

Marking schemes published by the State Examinations Commission are not intended to be standalone documents. They are an essential resource for examiners who receive training in the correct interpretation and application of the scheme. This training involves, among other things, marking samples of student work and discussing the marks awarded, so as to clarify the correct application of the scheme. The work of examiners is subsequently monitored by Advising Examiners to ensure consistent and accurate application of the marking scheme. This process is overseen by the Chief Examiner, usually assisted by a Chief Advising Examiner. The Chief Examiner is the final authority regarding whether or not the marking scheme has been correctly applied to any piece of candidate work.

Marking schemes are working documents. While a draft marking scheme is prepared in advance of the examination, the scheme is not finalised until examiners have applied it to candidates' work and the feedback from all examiners has been collated and considered in light of the full range of responses of candidates, the overall level of difficulty of the examination and the need to maintain consistency in standards from year to year. This published document contains the finalised scheme, as it was applied to all candidates' work.

In the case of marking schemes that include model solutions or answers, it should be noted that these are not intended to be exhaustive. Variations and alternatives may also be acceptable. Examiners must consider all answers on their merits, and will have consulted with their Advising Examiners when in doubt.

### **Future Marking Schemes**

Assumptions about future marking schemes on the basis of past schemes should be avoided. While the underlying assessment principles remain the same, the details of the marking of a particular type of question may change in the context of the contribution of that question to the overall examination in a given year. The Chief Examiner in any given year has the responsibility to determine how best to ensure the fair and accurate assessment of candidates' work and to ensure consistency in the standard of the assessment from year to year. Accordingly, aspects of the structure, detail and application of the marking scheme for a particular examination are subject to change from one year to the next without notice.



*Leaving Certificate Examination, 2016*

***Technology***

*Higher Level*

***Marking Scheme***

***Section A - Core*** (72 marks)

**Section A.** Answer *any twelve* questions. All questions carry 6 marks.

1. *Product evolution* is seen in the development of mobile phone technology.

(i) Identify a recent development in the evolution of mobile phone technology.

**Reducing phone size, video, wifi, bluetooth, touchscreen, etc.**

(ii) Outline **one** impact of continuous evolution on product lifecycle.

**Shorter lifecycle, more waste/pollution, regular improvements can maintain product attractiveness, etc.**



(3+3 marks)

2. Infrared technologies are used in industrial, scientific and medical applications.

(i) Describe **one** advantage of infrared technology.

**Instant thermal inspection, wireless transmission, less prone to interference, low power requirement, etc.**

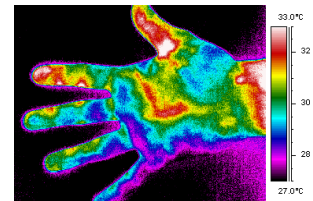

(ii) Outline how infrared technology can be used in communication applications.

**IR data transmission is employed in short-range communication among computer peripherals and personal digital devices. Remote control devices use infrared LEDs to emit infrared radiation that is focused by a plastic lens into a narrow beam.**

(3+3 marks)

3. *Food miles* is the distance food travels from the farm to our plates. Energy is used to grow, process, transport and store food.

Analyse the impact of the food miles concept using the following headings:

(i) Packaging and transport.

**Packaging must be able to withstand long transport trips and keep food fresh.  
Transport costs use energy, refrigeration and fuel to move food from source to customer.  
Increased carbon footprint, etc.**

(ii) Seasonal production of food.

**Seasonal production reduces carbon footprint by only using food that is in season/ not refrigerated or transported long distances, less preservatives required, etc.**

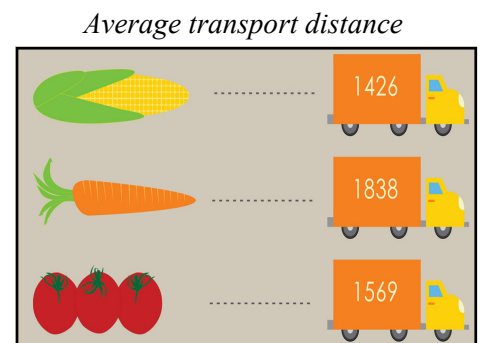

(2+2+2 marks)

4. *Skylock* is a keyless bike lock that uses multi-sensor technology to provide *remote monitoring* and crash alerts to keep you and your bike safe. The lock includes solar charging capability, can be activated using a mobile phone. It is made from *hardened* steel with an impact resistant rubber shell.

(i) Explain the term remote monitoring.

**Allows an alert to be transmitted from the device to the user's phone/ipad, etc. when the device is tampered with.**



(ii) Explain what is meant by hardness as a material property?

**The ability of a material to resist scratching or indentation.**

(3+3 marks)

5. Australian designer, Marc Newson, designed his 'Gluon Chair and Ottoman' in 1993. The sides of the chair are made from lacquered *polyurethane*.

Suggest **two** reasons for the selection of polyurethane as a suitable material.

**Can have a shiny finish in a range of colours, relatively tough and hard thermoset plastic, can be cast or moulded into shape, etc.**



(3+3 marks)

6. A resistor with a gold band denotes a 5% tolerance.

(i) State the minimum and maximum values of a 470Ω resistor with a gold band.

Minimum value: <b>446.5 Ω</b>	Maximum value: <b>493.5 Ω</b>
-------------------------------	-------------------------------

(ii) If the total resistance in the circuit is 24Ω, calculate the value of resistor

Calculation:	
$\frac{1}{R_t} = \frac{1}{R_2} + \frac{1}{R_3}$	$R_1 = 24 - R_t$
$\frac{1}{4} = \frac{1}{5} + \frac{1}{20}$	$= 24 - 4 = 20 \Omega$
$R_t = 4 \Omega$	<b>Answer: R1= 20Ω</b>

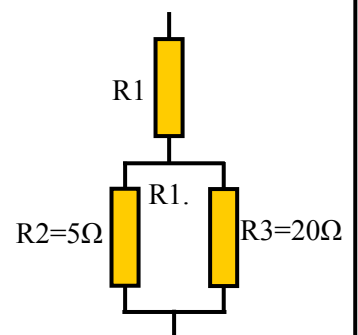

(2+4 marks)

7. Analyse the environmental impact of manually soldering a circuit as part of a technology project in terms of:

(i) Energy use.

**Heat must be generated in order to use a soldering iron to melt the solder, this is usually supplied by electricity. Fumes may need to be extracted using electric fans.**

(ii) Soldering materials used.

**Solder is made from lead and tin, they are both difficult and expensive to mine and process. Tin is a relatively rare metal. Lead mining and lead use leaves a toxic residue that needs to be dealt with carefully.**

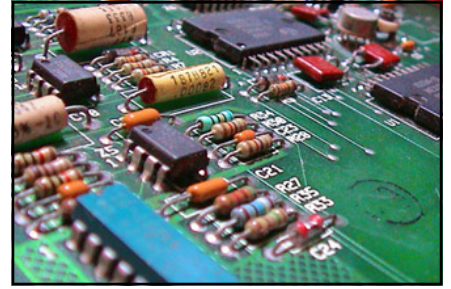

(3+3 marks)

8. *Product reliability* is often charted as a ‘bathtub’ graph with three distinct phases. Describe **each** of these phases.

Phase 1

**Early failures gradually are solved and reduced as the product gets established.**

Phase 2

**A reasonably constant failure rate with only random failures.**

Phase 3

**The product becomes less reliable with wear-out failure a feature of this stage.**

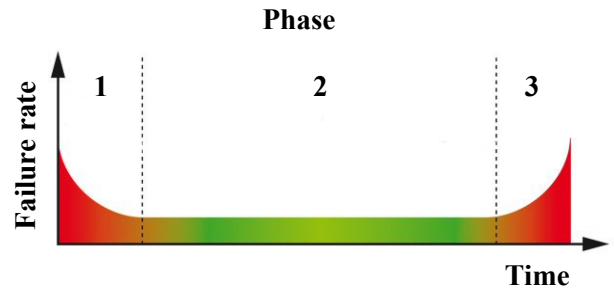

(2+2+2 marks)

9. The testing machine shown uses a *cam* and *follower*.

(i) Name the type of follower shown.

**Plate or flat follower.**

(ii) Sketch the typical profile of a snail cam (drop cam).

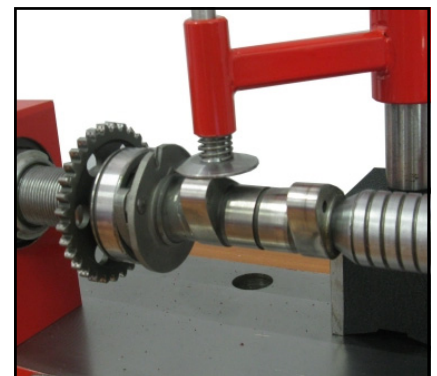
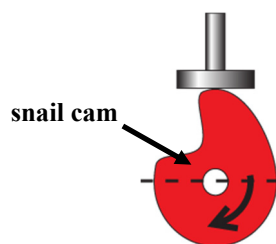

(2+4 marks)

10. (i) Identify the *class of lever* used in the bicycle brake mechanism shown.

**Class 1 lever.**



- (ii) Calculate the effort required for the lever shown below.

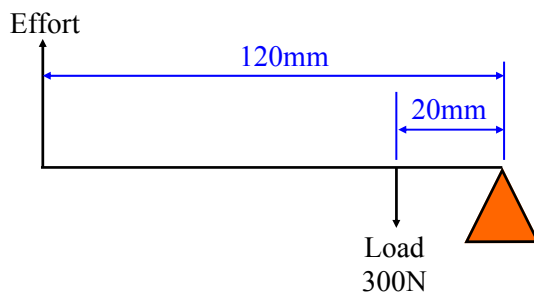

Calculation:

$$\text{Effort} \times 0.12\text{m} = 300\text{N} \times 0.02\text{m}$$

$$\text{Effort} = 50 \text{ N}$$

(2+4 marks)

11. (i) Explain the term *Computer Aided Manufacturing*.

**Computer-aided manufacturing (CAM) is an application technology that uses computer software and machinery to facilitate and automate manufacturing processes.**

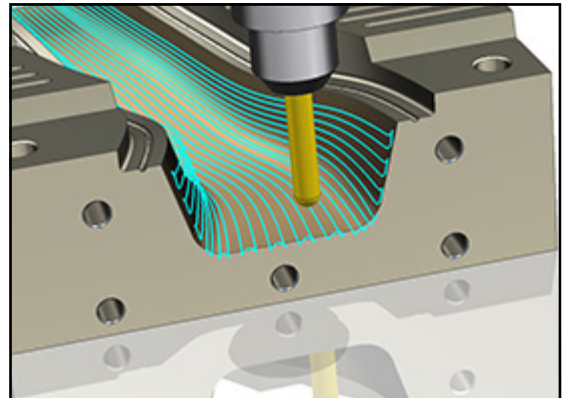

- (ii) Describe a specific use of **each** of the following computerised technologies:

CNC lathe.

**CNC lathes can machine cylindrical materials to a predetermined profile/shape, e.g shafts, bolts, knobs, etc.**

3D printing.

**3D printing creates products layer by layer using a printing head in a range of materials (additive process). Examples include prototypes, toys, individual parts, etc.**

(2+4 marks)

12. (i) Arrange the following units in order of **increasing** size:

1. **100 kilobyte**
2. **1 gigabyte**
3. **1 terabyte.**



(ii) 1000 bytes is commonly referred to as 1 kilobyte.  
State the number of bytes in each of the following:

A document of 196 KB                    **196,000 bytes.**

A photograph of 4 MB                    **4,000,000 bytes.**

*(3+3 marks)*

13. An exploded view of a hairdryer is shown.  
Make a well-proportioned freehand sketch of **one** orthographic view of the **assembled** hairdryer.

**Any one orthographic view (elevation, plan, either end view) of assembled hairdryer.**



*(6 marks)*



**14.** The wind-up torch shown incorporates a number of ergonomic design considerations.

Identify **two** ergonomic features of the wind up torch shown and explain the function of each feature identified.

**The strap prevents you dropping the torch on the floor if you lose grip on the handle. It also allows the torch to be hooked onto a belt.**

**The handle has a textured surface to prevent slipping and is moulded to the shape of the hand. The diameter makes it easy to hold.**

**The wind-up handle is long enough to make winding easy, it can also fold away easily.**

**The shape of the torch body is comfortable to hold.**

**The lens cover is serrated to allow easy opening and closing of the torch cover.**



*(3+3 marks)*

**15.** Use **two** graphic techniques to enhance the representation of the remote control shown.

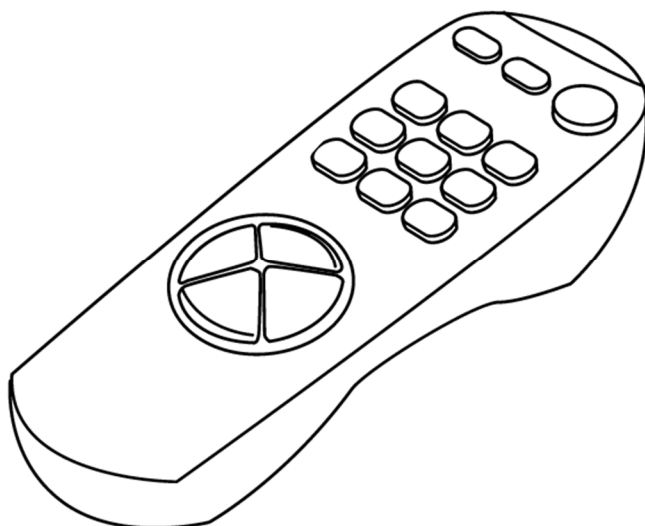

**Two distinct graphic techniques required.**

*(3+3 marks)*

Blank Page



***Leaving Certificate Examination, 2016***

# ***Technology***

***Higher Level***

## ***Marking Scheme***

### ***Section B - Core*** (48 marks)

*Answer both questions.*

*Each question in Section B carries 24 marks.*

### ***Section C - Options*** (80 marks)

*Answer two of the five options presented.*

*All questions in Section C carry 40 marks.*

## Section B - Core - Answer Question 2 and Question 3.

**Question 2 - Answer 2(a) and 2(b)** (a) - 8 marks, (b) - 10 marks, (c) OR (d) - 6 marks

2(a) (i) Outline **two** communication technologies that could be used in telemedicine.  
**Email, teleconferencing, remote monitoring of symptoms equipment, smart watches, etc.**

(ii) Suggest **two** benefits of the widespread use of telemedicine techniques.  
**The use of expertise is not limited by location or time, less hospital time as more patients can be treated at home, on-going monitoring of lifestyle, etc.** (8 marks, 4+4)

2(b) (i) Name **one** type of motion demonstrated in the prosthetic hand shown.  
**Oscillating motion.**

(ii) Describe, using annotated sketches, the electro-mechanical operation of the pinching movement of the thumb and finger of the hand shown opposite.  
**Miniature motors/servo can be connected to the linkages and move these linkages causing the fingers to open and close, etc.**

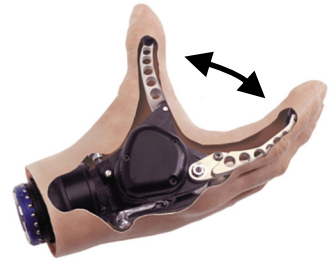

(iii) Suggest a suitable material for the linkages in the prosthetic hand. Justify your answer making reference to material properties.

**Suggestion: Titanium is lightweight, bio-compatible and strong.**  
**Stainless steel- non-reactive, corrosion resistant, clean, etc.**

(10 marks, 2+4+4)

**Answer 2(c) or 2(d)**

2(c) (i) Explain the term 'Factor of Safety of 5' and outline why is it critical in the design of prosthetic devices.  
**The factor of safety means that the parts of the hand can withstand 5 times the force necessary to operate the device. This is necessary to cater for other external forces that may act on the hand.**

(ii) Describe, with the aid of annotated sketches, a typical circuit to operate a motor providing an 'open and close' pinching movement.

**The motor is likely to be controlled by:**  
**programmable microcontroller circuit/ servo motor,**  
**DPDT switch/relay, etc.**



(6 marks, 3+3)

**OR**

2(d) (i) Distinguish between the processes of 3D scanning and 3D printing.

**3D scanning will collect data and analyse an object to construct a computerised 3 dimensional model of the object. A 3D printer can take this model to manufacture an actual model of the object.**

(ii) Outline the impact of open source, 3D scanning and 3D printing on the affordability of prosthetic hands.

**Open source refers to a program in which the source code is available to the general public for use and/or modification from its original design free of charge. This allows users to modify and improve the original software without the expense of buying software making design of devices more affordable.**

**3D scanning allows prosthetic devices to be customised for individual users making them more comfortable and versatile.**

**3D printing allows users to print the latest designs from any location at a fraction of the cost**

(6 marks, 3+3)

**Question 3 - Answer 3(a) and 3(b)**

(a) - 8 marks, (b) - 10 marks, (c) OR (d) - 6 marks

- 3(a) (i) Outline **two** advantages of the use of carbon fibre in the design of the Alex roadster.  
**Carbon fibre is lightweight, can be moulded into intricate shapes, strong, etc.**
- (ii) Describe **one** significant challenge which has limited the success of electric car technology to date.  
**Battery life has impacted on range of trips possible. Battery size has added considerably to the weight of electric cars. Charging points are limited at present, carrying capacity, etc.** (8 marks, 4+4)
- 3(b) (i) Calculate the cost of operating an 80kW machine, at full load, for 2 hours if a unit of electricity costs 18.5 cent.  
**Power = 80kW x 2 hours = 160 kWh**  
**Cost = 160 x 0.185 = €29.60**
- (ii) Suggest **two** sources of loss of energy in an electric motor.  
**Heat generated due to moving parts, friction absorbs energy, eddy currents losses, etc.**
- (iii) Explain the possible role of the solar panels on this car.  
**Solar panels could be used to assist in charging the car battery system and prolong journey range.** (10 marks, 4+4+2)

**Answer 3(c) or 3(d)**

- 3(c) (i) Using annotated sketches, suggest an aerodynamic body-profile for the car to improve its efficiency and speed.  
**Air drag and body form to reduce turbulence are key factors in car aerodynamics, etc.**
- (ii) Outline the **advantages** of both:
- a chain and sprocket drive *and*  
**Strong drive, not likely to break or slip.**
  - a toothed belt drive



(6 marks, 2+4)

**OR**

- 3(d) (i) Explain the purpose of compiling a Gantt chart as part of the planning process for the production of the prototype race car.  
**Plan and schedule the individual parts of a project to maximise efficiency and reduce waste.**
- (ii) **Draw Gantt chart:**

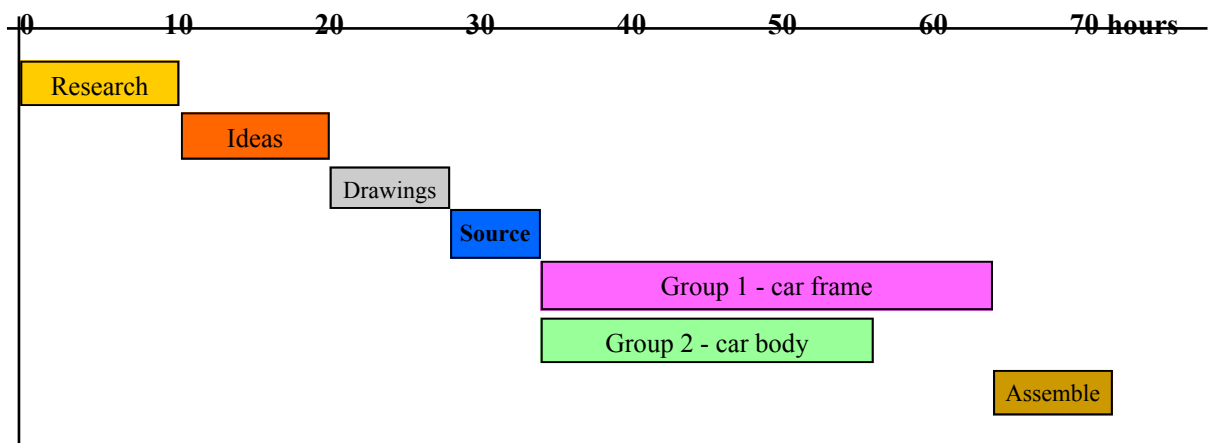

(6 marks, 2+4)

# Section C - Options - Answer any two of the Options.

## Option 1 - Applied Control Systems - Answer 1(a) and 1(b)

(a) - 10 marks, (b) - 16 marks, (c) OR (d) - 14 marks

1(a) (i) Name **two** products that use microcontrollers.

**Telephone systems, washing machines, car control systems, computer games, etc.**

(ii) Suggest **two** input devices and **two** output devices used with microcontrollers.

**Inputs - switches, timing devices, LDR, thermistor, motion sensors, etc.**

**Outputs - lights, motors, fans, pumps, etc.**

(10 marks, 6+4)

1(b) (i) **Complete flowchart:**

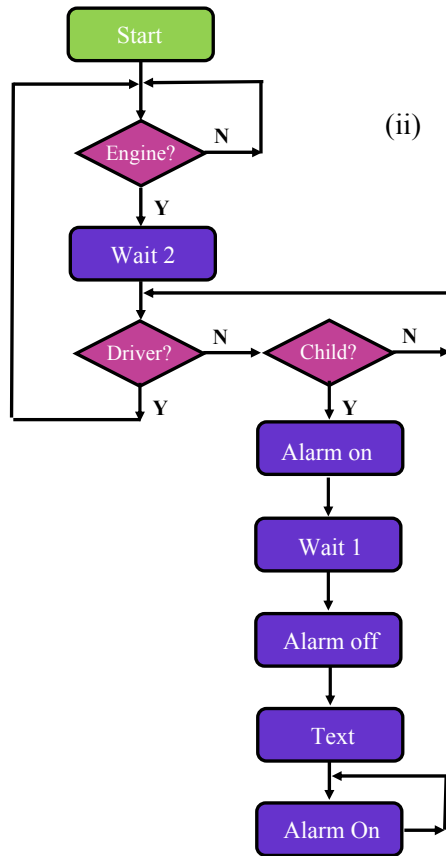

(ii) Suggest a suitable sensing system to check for the presence of the child in the car seat.

**Pressure switch on bottom of seat, heat or motion sensor, etc.**

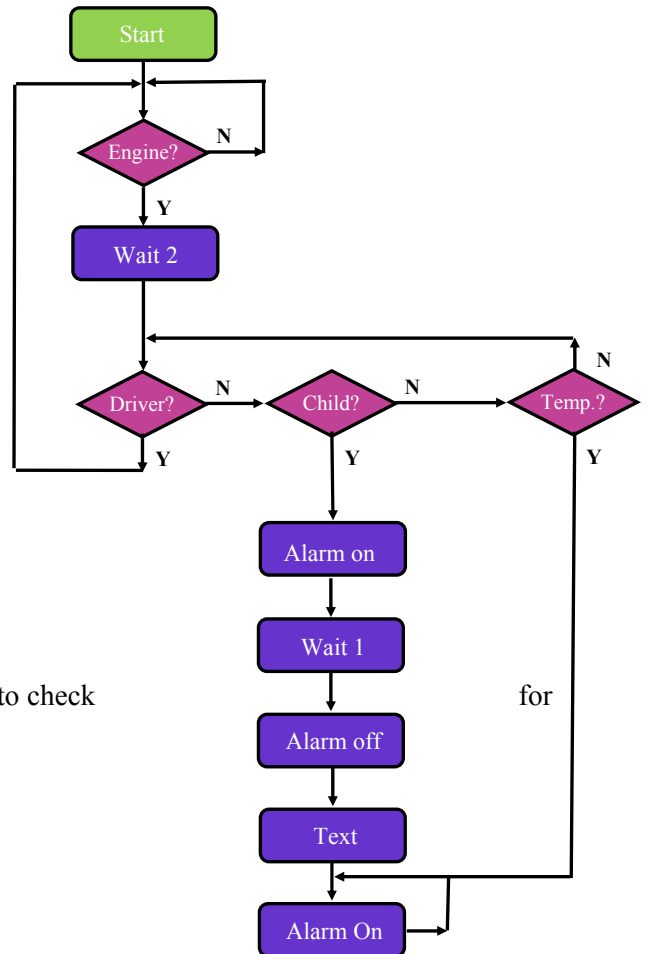

(iii) Suggest a modification to your flowchart sequence to check excessive build-up of heat in the car.

**Temperature rise to sound alarm.**

**Any valid alternative solution accepted.**

(16 marks, 10+2+4)

*Answer 1(c) or 1(d)*

**1(c)** (i) Name and describe the main features of the robotic arm shown.

**The SCARA robot has two parallel revolute joints and a prismatic joint to move vertically. It can be programmed to grasp or place objects, lift from one place to another and move in a cylindrical motion. They are relatively easy to set up and may be used to ‘pick and place’ objects.**

(ii) Describe, using annotated sketches, the work envelope of the robotic arm shown.

**It can be described as a kidney shaped prism, the work envelope of a scara robot covers a large area horizontally but can be limited vertically, etc.**

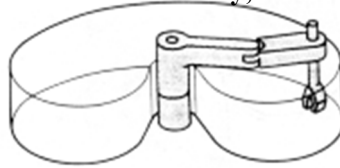

*(14 marks, 8+6)*

**OR**

**1(d)** (i) Suggest **two** reasons why pneumatic control systems are sometimes used in preference to electrical systems.

**Reduced fire hazard, strong drive delivered, reliability with reduced moving parts, etc.**

(ii) Draw a diagram of a pneumatic circuit for dispensing the table tennis balls.

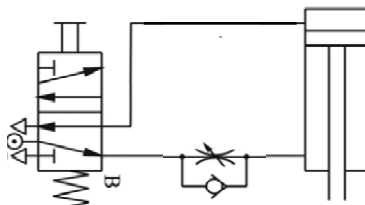

*(14 marks, 6+8)*

## Option 2 - Electronics and

(a) - 10 marks, (b) - 16 marks, (c) OR (d) - 14 marks

- 2(a) (i) Outline **two** home automation systems that can be controlled to enhance convenience, energy efficiency or security.

**Remote control of security systems allows alarms to be set and status checked, heating systems can be set in advance of returning home and sensors can maintain heat at a suitable level, etc.**

- (ii) Discuss some privacy concerns arising from automation and the automatic capture of large amounts of data (Big Data).

**Large volume of valuable information is captured with concerns such as lack of anonymity, embarrassment due to breaches of privacy, data analysis may not be accurate,**

(10 marks, 6+4)

- 2(b) (i) Name the main components and give the function of each.

**Input - LDR, potential divider. Process - Op-amp. Output - LED**

- (ii) Describe the operation of this circuit

**The basic principle of this circuit is to compare the voltages at the Op-Amp. The potential divider at R1 and R2 provides a reference voltage. The LDR and resistor provide a potential divider circuit with the voltage from this part of the circuit feeding into the Op-Amp. As light level changes, the resistance of the LDR changes. When the voltage into the Op-Amp rises, the output of the IC is**

- (iii) Redraw the circuit diagram to include a relay which controls a 220V oil pump.

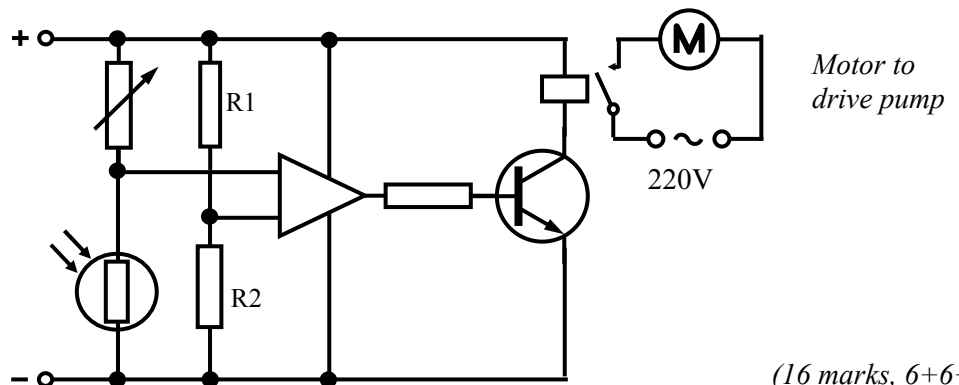

(16 marks, 6+6+4)

Answer 2(c) or 2(d)

- 2(c) (i) State the purpose of the de-bounce stage.

**Manual switching into a digital circuit may give multiple inputs from a single press, the de-bounce stage will counteract this.**

- (ii) Describe the operation of suitable components for the following:

- entry switching  
**A microswitch attached to the turnstile can be used to record entry, pressure pads, etc.**
- display device  
**The LED counter display will record and count entry and give a visual output display.**

(14 marks, 6+8)

**OR**

- 2(d) (i) Name the logic gates 1, 2 and 3 in the circuit shown.

- (ii) **Draw truth table**

1. **NOT/Inverter**
2. **AND gate**

3. **OR gate.**

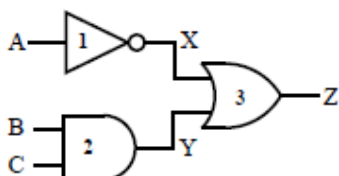

(14 marks, 6+8)

A	B	C	X	Y	Z
0	0	0	1	0	1
0	0	1	1	0	1
0	1	0	1	0	1
0	1	1	1	1	1
1	0	0	0	0	0
1	0	1	0	0	0
1	1	0	0	0	0
1	1	1	0	1	1



### Option 3 - Information and

(a) - 10 marks, (b) - 16 marks, (c) OR (d) - 14 marks

3(a) (i) Describe briefly what is meant by cloud computing.

**The use of a network of remote servers hosted on the Internet to store, manage and process data, rather than a local server or a personal computer.**

(ii) Outline, using appropriate examples, the benefits and limitations of using remote systems for storing electronic files.

**Benefits: Cost savings on storage devices, reliable and consistent storage, eliminate updates and maintenance, etc.**

**Limitations: If internet connection fails data cannot be accessed, responsibility for security of data is transferred to provider, vendor lock-in has not yet been** (10 marks, 4+6)

3(b) (i) Distinguish between the function of *registers*, *cache* and *main memory* as types of primary storage.

**Registers: A quickly accessible location available to a digital processor's central processing unit. Registers usually consist of a small amount of fast storage.**

**Cache: A high-speed storage mechanism which can be either a reserved section of main memory or an independent high-speed storage device.**

**Main memory: The primary memory of a computer, it stores the programs and data while they are being processed.**

(ii) Describe **two** modes of long term data storage making reference to capacity, volatility and accessibility.

**Optical storage devices such as CD and DVD have relatively low storage capacity (4.7GB), are non-volatile and with slow write, fast read accessibility.**

**External disk drives have large storage capacity (1TB), are non-volatile and have reasonable write, fast read accessibility.**

(iii) Outline the main features of a *compressed* file.

**File is made smaller allowing the file to be sent faster and needs less bandwidth.**

**The file needs to be decompressed to normal size when accessed.** (16 marks, 6+6+4)  
*Answer 3(c) or 3(d)*

3(c) (i) Distinguish, with examples, between LAN and WLAN.

**LAN: Local Area Network (computers networked together), uses electric signals to transmit data, has wired connections.**

**WLAN: Wireless Local Area Network (computers networked together without a cable), uses high energy radio frequency waves to transmit data, can be subject to interference.**

(ii) Explain *interference*, *absorption* and *reflection* as influences on the performance of a wireless network.

**Interference: Signals operating at similar frequencies can cause interference with each other and have a significantly negative effect on the performance of the network.**

**Absorption: This is the weakening of a wireless signal that occurs as it passes through objects especially those made of metal or water.**

**Reflection: Some of the signal power may be reflected back to its origin ra-** (14 marks, 8+6)

### OR

3(d) (i) Distinguish between *bitmap* and *vector* graphics in terms of image encoding, file size and editing.

**Bitmap: These graphics use less processing power than vector, takes up more memory due to large file size and is less precise.**

**Vector: These graphics are created by mathematical calculations, can be edited without loss of clarity with individual parts edited independently and grouped.**

(ii) Give a typical file extension for **each** of these multimedia elements.

<b>Text:</b>	<b>.wps, .doc, .txt</b>	<b>Sound:</b>	<b>.mp3, .wav</b>
<b>Images:</b>	<b>.bmp, .jpg, .gif</b>	<b>Video:</b>	<b>.avi, .mpg, .wmv</b>

## Option 4 - Manufacturing Systems - Answer 4(a) and 4(b)

(a) - 10 marks, (b) - 16 marks, (c) OR (d) - 14 marks

4(a) (i) Outline the main stages in the life cycle of a mass-produced electronic product.

**Introduction:** After all research and development is complete, the product is launched. The product may have few competitors and sales may remain low and it may take time for the market to accept the new product.

**Growth:** The market has accepted the product and sales begin to increase. The company may want to make improvements to the product to stay competitive.

**Maturity:** Sales will reach their peak. Other competitors enter the market with alternative solutions and increasing competition.

**Decline:** Sales begin to decline as the product reaches its saturation point. Most products are phased out of the market at this point due to the decrease in sales and because of competitive pressure. The market will see the product as old and no longer in demand.

(ii) *Re-branding* a product or service can impact on its life cycle. Suggest **two** benefits for the business and **two** benefits for the consumer of redeveloping and re-launching a brand identity following a process of market research.

**Benefits for the business:**

Brand loyalty will still exist, revitalisation of product or service with a new image, market repositioning can generate sustained growth, long term success due to relaunch, etc.

**Benefits for the consumer:**

(10 marks, 6+4)

4(b) (i) Explain the terms UCL and LCL.

**UCL:** Upper Control Limit

**LCL:** Lower Control Limit

(ii) Using the control chart shown, describe where the process is *out of control*. Suggest **one** indicator that predicts that the process may not remain in control.

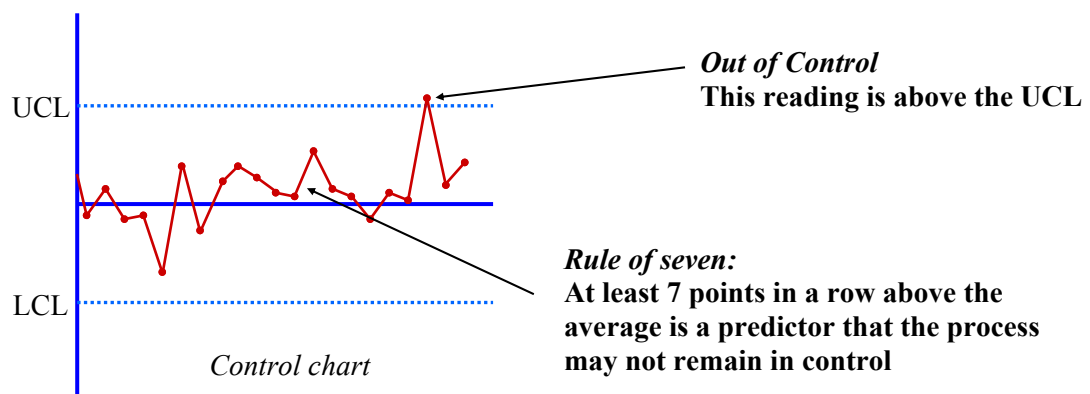

(iii) Distinguish between *Quality Control* and *Quality Assurance* in a manufacturing context.

**Quality Control:** This ensures products and services meet consumer expectations, it is product oriented and focuses on defect identification.

**Quality Assurance:** This is the process or set of processes used to measure and assure the quality of a product and focuses on defect prevention. (16 marks, 4+6+6)

Answer 4(c) or 4(d)

4(c) (i) Draw a graph to show the cost of each packaging method.

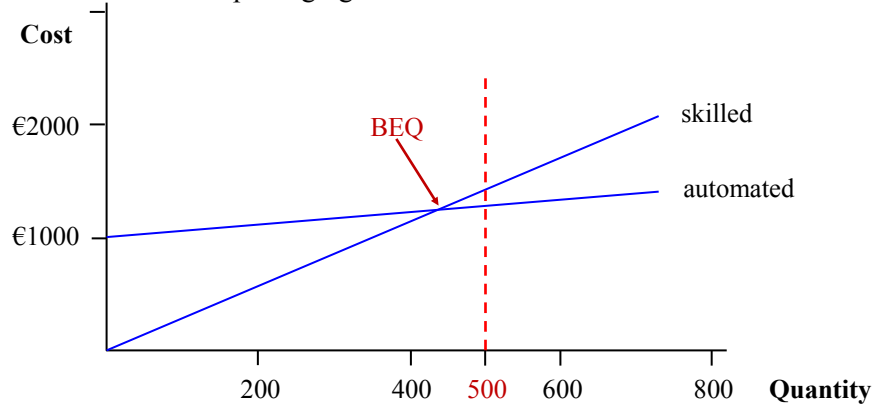

(ii) Break-even quantity (BEQ) =  $\frac{\text{Set-up cost}}{\text{Manual cost/item} - \text{Automated cost/item}} = \frac{1000}{2.5 - 0.1} = 417 \text{ units}$  (14 marks, 10+4)

OR

4(d) (i) Describe, using annotated sketches, two types of facility layout.

**Product layout**

- Activities arranged in sequence.
- Line set up to make one product
- Machines are specialised
- Automated process suitable for mass production
- Efficient with flow to minimise congestion

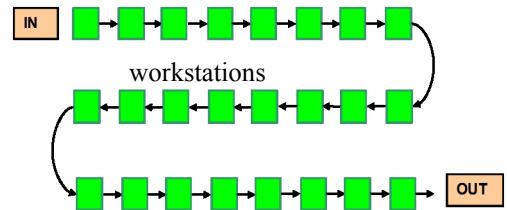

**Process layout**

- Work areas group similar activities
- Used for low volume or batch production
- Products are flexible
- Prone to storage of large volumes of materials

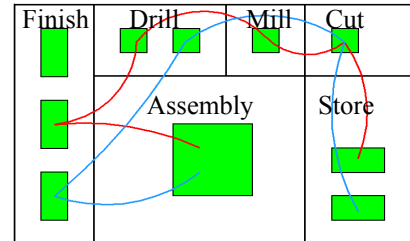

(ii) Suggested solution for a facility layout in the production of fuse-boxes

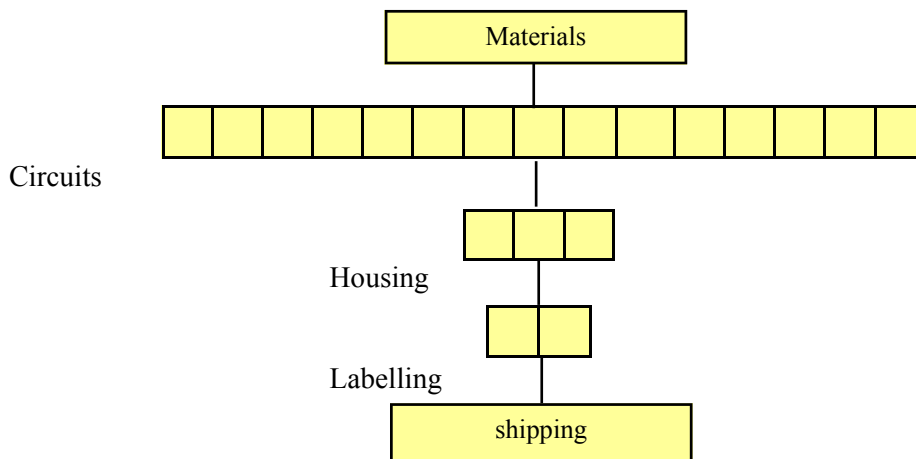

(14 marks, 8+6)

## Option 5 - Materials Technology - Answer 5(a) and 5(b)

(a) - 10 marks, (b) - 16 marks, (c) OR (d) - 14 marks

- 5(a) (i) Outline **three** properties of plywood that make it a suitable material for the manufacture of hoverboard or skateboard decks.  
**Strength of material, can be bent to shape, cuts to shape easily, finishes well, flexible, etc.**

- (ii) Describe a simple material test which could be used to determine if a given material is suitable for use in skateboard wheels.

**Load a material test sample against a rotating wheel and then deposit sand of controlled grit size, composition, and flow rate between them.**

**The mass of the test sample is recorded before and after conducting the test and the difference between the two values is the resultant mass. This can be compared to other samples.**

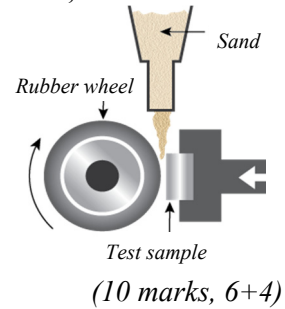

- 5(b) (i) Select a suitable material for the anti-slip surface on the pedal pads. Justify your answer.  
**Rubber. It is a reasonably soft material that wears well giving good grip.**

- (ii) Describe, using annotated sketches, a suitable production method for the plastic housing.

**Injection moulding: plastic pellets are loaded from the hopper through the heated chamber. It is pushed into the housing shaped mould by the rotating screw.**

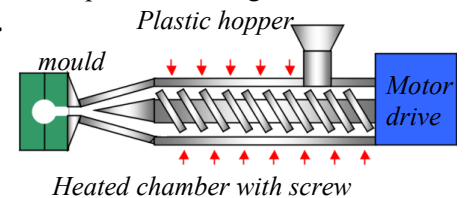

- (iii) Outline, using annotated sketches, a method of joining these parts together while accommodating



**Cylinder has splayed edges to prevent the two parts splitting**



**The chassis can be made in two separate parts that are joined together by an internal cylinder. This allows both parts to rotate.**

(16 marks, 4+6+6)

Answer 5(c) or 5(d)

- 5(c) (i) Why are *batch production* techniques appropriate for this limited edition?

**Reduced initial and operating costs, greater flexibility producing smaller quantities rather than continuous manufacturing processes, etc.**

- (ii) Describe appropriate processes for the safe manufacture of this deck.

**The shape is marked out on the plank of oak. It can be cut with a band saw and then planed to shape. The wood can then be sanded by machine sanding and followed by hand sanding. When smooth, a series of coats of exterior varnish is applied with each layer allowed**

(14 marks, 6+8)

OR

- 5(d) (i) Suggest **two** alternative materials for takeaway coffee cups which can be recycled or will biodegrade.  
**Paper, cardboard, glass, PLA-lined cups, etc.**

- (ii) Describe **two** advantages of incineration as a method of disposing of expanded polystyrene.

**Saves sending to landfill, waste disposal for long life material, acts as a fuel for incineration, etc.**

(14 marks, 6+8)

Blank Page

Blank Page

Blank Page

