



*Leaving Certificate Examination, 2012*

# *Technology*

## *Higher Level*

*Friday, 22 June*  
*Afternoon, 2:00 - 4:30*

### ***Section B - Core*** (48 marks)

*Answer both questions.*

*Each question in Section B carries 24 marks.*

### ***Section C - Options*** (80 marks)

*Answer two of the five options presented.*

*All questions in Section C carry 40 marks.*

#### ***Instructions:***

- (a) *Answer these questions in the answerbook provided.*
- (b) *Write your examination number on the answerbook.*
- (c) *Draw all sketches in pencil.*
- (d) *Hand up the answerbook at the end of the examination.*

## Section B - Core - Answer Question 2 and Question 3.

### Question 2 - Answer 2(a) and 2(b)

2(a) The launch of the Olympic stadium in London featured a 3D model of the new structure. The model was produced directly from a CAD file using a 3D printer.

- (i) Outline **two** reasons for producing a model of the stadium.
- (ii) Outline **two** ways in which technology assists athletes in preparation for the Olympic games.



2(b) A PCB board for a novelty Olympic games themed toy is shown.

- (i) Name the components **A**, **B** and **C**.
- (ii) Component **B** can be *polarised*. Explain the term polarised.
- (iii) State **two** advantages of using LEDs rather than light bulbs in this toy.

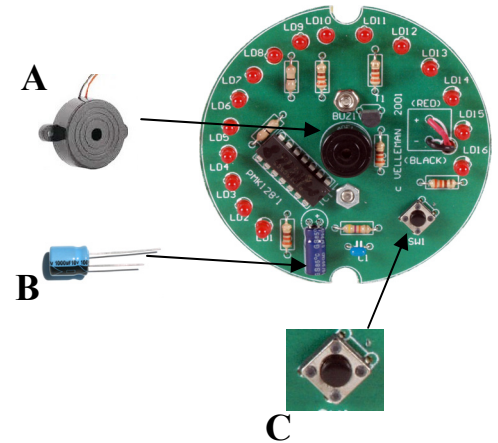

### Answer 2(c) or 2(d)

2(c) Newly introduced models of smartphones go through a sequence of stages known as a *product life cycle*.

- (i) Explain the term product life cycle.
- (ii) Using a smartphone as an example, describe the **four** stages of the product life cycle.

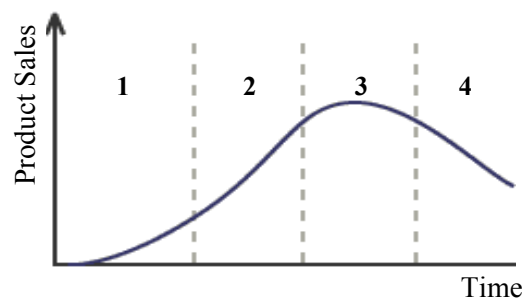

OR

2(d) Traditionally, posters and billboards were used to advertise products and services at major sporting events and festivals. In recent years technology has changed many aspects of the advertising industry.

- (i) Explain what is meant by "*Product Placement*" and give an example of where it might be used.
- (ii) Outline **two** forms of promotion that use online advertising.

**Question 3 - Answer 3(a) and 3(b)**

**3(a)** In recent years, the Irish government has encouraged the use of diesel and *hybrid* cars through tax incentives.

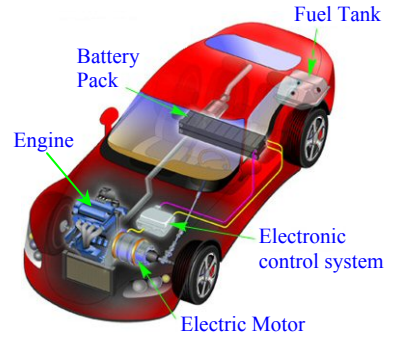

- (i) State the meaning of the term hybrid.
- (ii) Outline **two** advantages of choosing to purchase a hybrid car rather than a petrol car.

**3(b)** A combination of *linkages* and *levers* is used to control the amount of petrol released into the car carburettor shown.

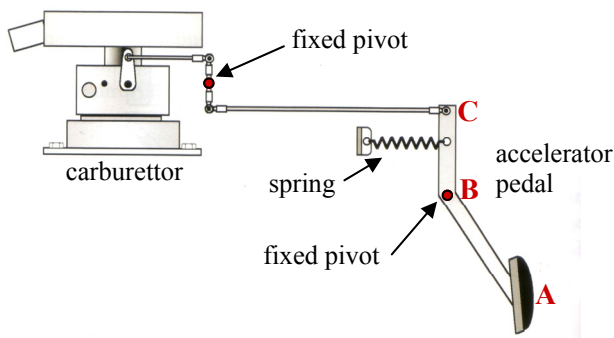

- (i) Distinguish between a linkage and a lever.
- (ii) What is the function of the spring?
- (iii) Determine the class of lever of the accelerator pedal and calculate the mechanical advantage if  $AB = 165\text{mm}$  and  $BC = 55\text{mm}$ .

**Answer 3(c) or 3(d)**

**3(c)** At the design and prototyping stage of car manufacture, methods such as computer simulation and wind tunnel testing are employed.

- (i) Outline **two** reasons for using computer simulation in car design.
- (ii) Outline **two** aspects of car design that can be tested using prototypes in a wind tunnel.

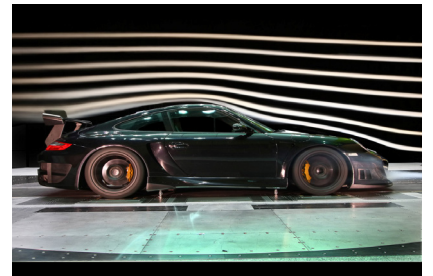

**OR**

**3(d)** The graphic shows an incomplete car steering system.

- (i) Name a mechanism used in a car steering system.
- (ii) Using notes and annotated sketches, describe the mechanism by which the wheels remain parallel as the car is steered.

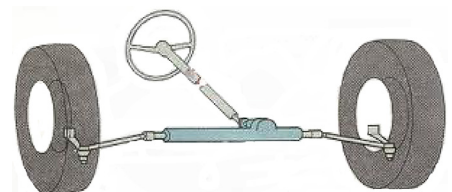

## Section C - Options - Answer any two of the Options.

### Option 1 - Applied Control Systems - Answer 1(a) and 1(b)

- 1(a) (i) Outline **three** advantages of the use of computer-aided manufacturing techniques in industrial production.
- (ii) Describe the role of remote control technology in a life-threatening environment such as a nuclear power station.



- 1(b) (i) Programmable PIC systems can be expensive to design and build, yet are widely used. Outline **three** advantages of using programmable chips.

- (ii) Shown is a hand dryer which is controlled using a PIC programme.

When the main power switch is turned on a green pilot light illuminates. The dryer motor starts automatically when hands are placed in it and remains on until the hands are removed. A touch-free sensor is used to detect the presence of hands in the dryer.

Compile a flowchart for the operation of the dryer.

- (iii) Using notes and annotated sketches, describe a touch-free sensor system suitable for this hand dryer.



### Answer 1(c) or 1(d)

- 1(c) (i) Describe the main features of a cartesian robot making reference to its work envelope and applications.
- (ii) Describe the purpose and operation of an *encoder* in closed-loop control.

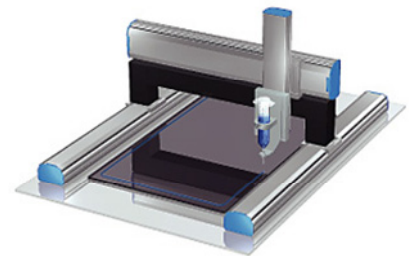

OR

- 1(d) (i) Give **two** common applications of pneumatic control.
- (ii) The graphic shows a pneumatically controlled machine used to test tennis balls by applying a consistent load. The piston compresses the ball when a push-button is pressed. On releasing the push-button, the piston retracts ready to advance the next ball.
- Draw a suitable pneumatic-control circuit for the operation of this machine.

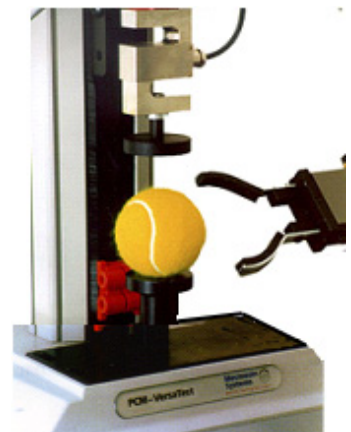

## Option 2 - Electronics and Control - Answer 2(a) and 2(b)

2(a) “Irish roads are safer than they have ever been, but there is no room for complacency”. (RSA, 2011 Annual Report)

- Describe **two** modern technologies that have contributed to making our roads safer.
- Identify **two** electronic safety features which are incorporated into modern cars and explain how they help improve driver safety.



2(b) An emergency breakdown sign is shown. The sign contains a number of LEDs which are controlled by an astable electronic circuit, similar to that shown below.

- Redraw the completed *astable* circuit, labelling all components.
- Distinguish between monostable and astable configurations.
- Calculate the value of R3 if the LED operates at 2V and 20mA.

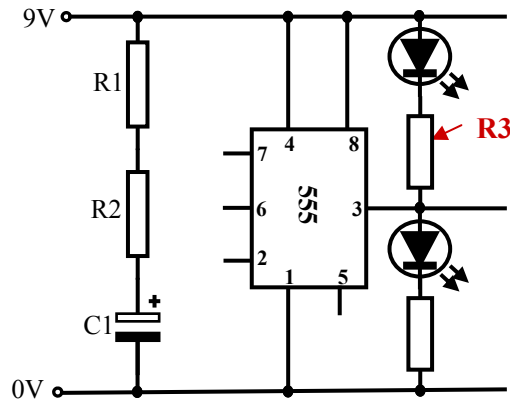

Answer 2(c) or 2(d)

2(c) A motor is interfaced to the logic output circuit shown.

- Name and state the function of **each** of the components A, B and C in this circuit.
- Calculate the gain of component C if the ammeter readings at  $I_B = 0.6\text{mA}$  and  $I_C = 90\text{mA}$ .

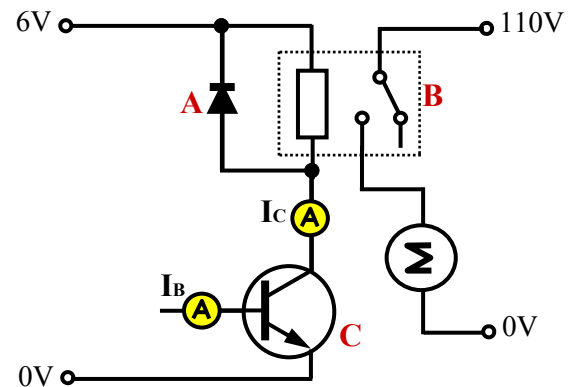

OR

2(d) A gardener builds a device to switch on a heater when there is frost at night. There is an override switch to turn off the device during the warmer summer months.

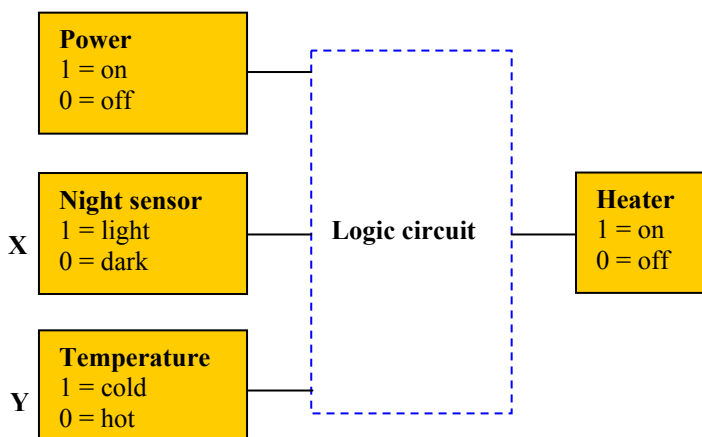

- Draw a logic gate and truth table for this system.
- Identify sensing components for use at X and at Y.

### Option 3 - Information and Communications Technology - Answer 3(a) and 3(b)

- 3(a) (i) Distinguish clearly between a *database* and a *spreadsheet*.
- (ii) Outline **two** factors that have made *tablet computers* one of the fastest growing consumer products in recent years.



- 3(b) (i) Explain the abbreviation **VoIP** making reference to a specific example of software and hardware required for such a system.
- (ii) State **two** advantages of using fibre optic cables instead of traditional copper cables for data transfer.
- (iii) Outline the main features of *peer networks* **and** of *client networks*.



#### Answer 3(c) or 3(d)

- 3(c) The 'motherboard' shown is the main circuit board for a computer system. System devices will be part of this motherboard or will be connected to it.
- (i) Name and state the function of **any three** parts of a computer motherboard.
- (ii) Outline a functional difference between ROM and RAM.



**OR**

- 3(d) (i) Distinguish clearly between computer *worms*, *trojans* and *spyware*.
- (ii) Internet security is a key issue when browsing the internet. Explain the use of *pop up blocker* and *phishing filter* tools to help protect the user from malicious content and fraud.



## Option 4 - Manufacturing Systems - Answer 4(a) and 4(b)

- 4(a) In March 2011, an earthquake in Japan triggered a devastating tsunami and an energy crisis as nuclear power plants were crippled. The world's largest car manufacturer, Toyota, was among the worst affected with the closure of the battery manufacturing and car assembly facilities for the company's hybrid car. In the aftermath of this tragic event, a focus on 'Just-In-Time' (JIT) supply chain practices has been evident.

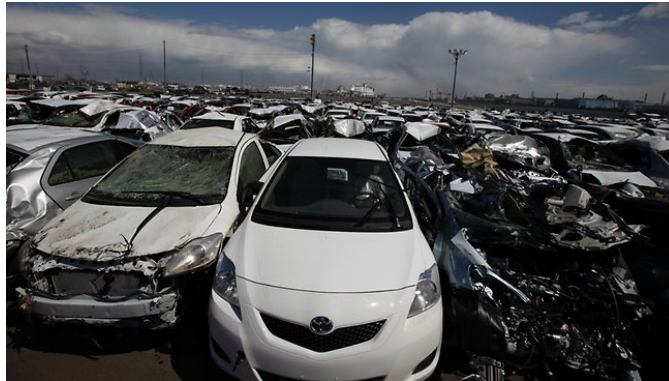

- (i) Describe the essential principles of JIT.
- (ii) Outline **two** implications of a significant break in supply chain for a JIT manufacturing system after an event such as the Japanese earthquake.
- 4(b) Measurement of samples from two manufacturers of the bearings shown yielded the following results:

Manufacturer A: standard deviation 0.0103

Manufacturer B: standard deviation 0.0123

The inner diameter of the bearing must not be smaller than 24.95mm and not bigger than 25.02mm.

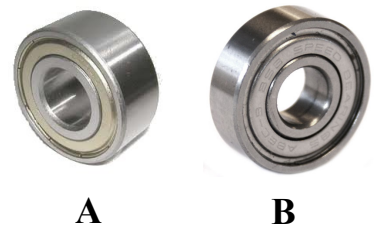

- (i) Calculate the *Process Capability Index* for each manufacturer where  $C_p = \frac{\text{Tolerance Range}}{6\sigma}$
- (ii) Which manufacturer should be chosen so that the bearings will always meet design specifications? Give **one** reason for your answer.
- (iii) Identify the graph which best represents the Process Capability of **each** manufacturer.

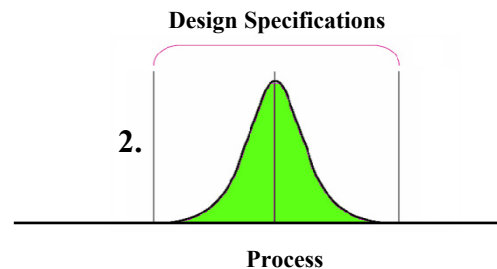
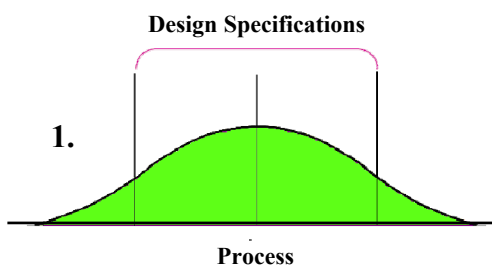

Answer 4(c) or 4(d)

- 4(c) (i) Distinguish between *Quality Control* and *Quality Assurance*.
- (ii) Companies exist to make a profit. Usually there is more than one company offering a particular item or service and therefore companies compete with one another for market share. To be competitive, a company needs to have a *strategy* which provides a focus for decision making.

A strategy consists of four steps:

1. Define a primary task
2. Assess core competencies
3. Determine order qualifiers and order winners
4. Position the firm.

Explain the **four** steps using examples in each case.

**OR**

- 4(d) (i) Name and explain each of the **four** steps of the Deming Cycle.
- (ii) A sports-shop supplies medals for all sporting activities. Blank medals are bought in and engraved manually.

An order for 750 medals was received from a local sports club. Due to the large order, the shop owner is considering buying an automated engraving machine.

The following data describes the choices available:

Engraving machine purchase cost - €390

Unskilled labour to operate the machine - €0.45 per medal

Skilled labour to manually engrave - €1.10 per medal.



For the 750 medals ordered:

- (a) Draw a graph to show the costs of each method of engraving the medals.
- (b) Determine the **BEQ** from the graph or otherwise.



## Option 5 - Materials Technology - Answer 5(a) and 5(b)

5(a) (i) Briefly compare and contrast the items in **each** of the following pairs of materials:

- Natural fabrics and synthetic fabrics
- Thermosetting plastics and thermoplastics
- Non-ferrous metals and ferrous metals.

Use specific examples to support your answer.

(ii) Outline the impact of acid rain on **each** of the following - mild steel, oak, acrylic.

5(b) Wheelchairs offer a significant degree of mobility for people who are incapacitated. There is a variety of models available for different applications.



- Select a suitable material for the frame of a user-powered wheelchair and justify your selection.
- Most frame parts are manufactured in tubular form. Outline **two** advantages of using tubes rather than solid sections.
- Explain, using notes and annotated sketches, a method of assembling the frame for the user-powered wheelchair.

Answer 5(c) or 5(d)

5(c) The plastic casing for the motor on an electric wheelchair is to be manufactured.

- Identify a suitable manufacturing process to make a batch of 100 such casings.
- Describe, using notes and annotated sketches, the process you have selected to produce the casings.



OR

5(d) Up-cycling is the process of converting waste materials or obsolete products into new materials or products of better quality or higher environmental value. Up-cycled products, such as the bags made from bicycle tubes shown, reduce *carbon footprint* and increase the focus on *sustainable design*.

- Explain the terms carbon footprint and sustainable design.
- Distinguish, using examples, between **each** of the elements of the waste disposal hierarchy of 'Reduce, Reuse and Recycle'.



**Blank Page**

**Blank Page**

**Blank Page**