



Leaving Certificate Examination 2008

Technical Drawing
Paper 1 – Ordinary Level
(Plane and Solid Geometry)

(200 Marks)

Friday 13 June
Afternoon, 2.00 - 5.00

Instructions

- (a) Answer four questions.*
- (b) All questions carry equal marks.*
- (c) Construction lines must be shown on all solutions.*
- (d) Write the number of the question distinctly on the answer paper.*
- (e) Work on one side of the paper only.*
- (f) All dimensions on the question paper are given in metres or millimetres.*
- (g) First or third angle projection may be used.*

1. An isometric view of a shaped solid is shown in Fig. 1.

- (a) Draw an elevation of the solid looking in the direction of the arrow.
- (b) Project a plan from the elevation.
- (c) Project a new elevation of the solid from the plan, which will show the true shape of the surface A.

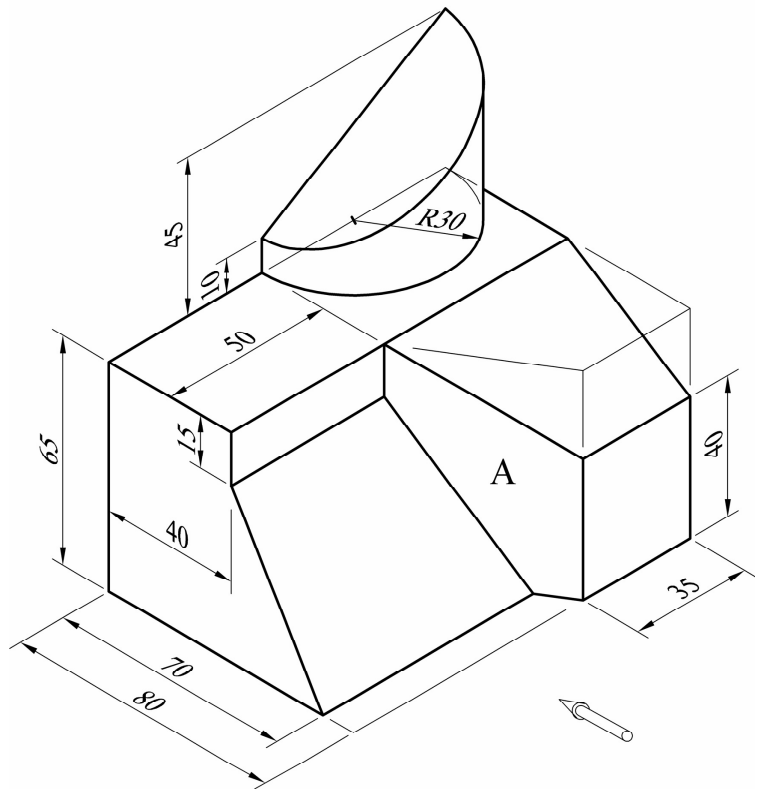

Fig. 1

2. Fig. 2 shows a quadrilateral ABCD which is divided into two triangles.

The sides of the triangle ACD are in a ratio of 2:4:5.

- (a) Draw the given figure, showing clearly the constructions required to locate the point D.
- (b) Draw a square, which shall be half the area of the figure ABCD.

All constructions must be clearly shown on the sheet.

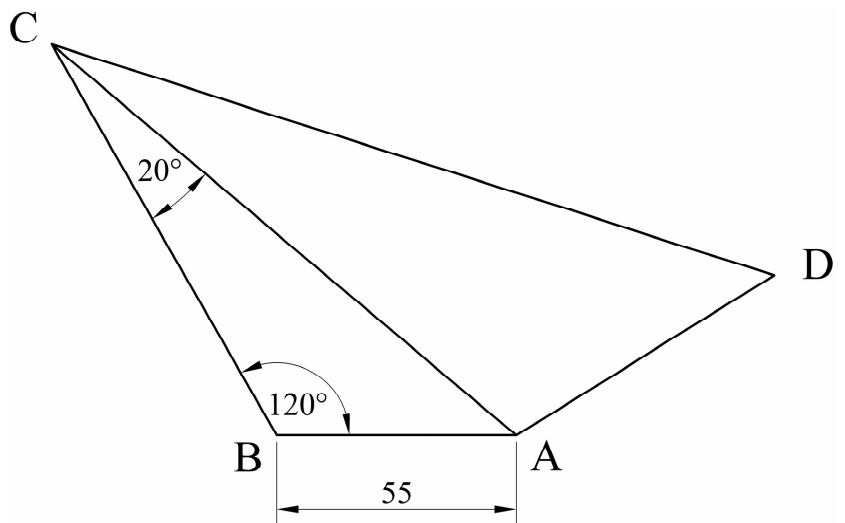

Fig. 2

3. Fig. 3 shows the elevation and plan of a cone A and a sphere B with a point P on its surface. The solids are in contact with each other as shown.

The plan of a sphere C, which rests on the horizontal plane and is in contact with both solids, is also shown.

- Draw the elevation and plan of the cone A and the sphere B.
- Draw the plan and elevation of the sphere C.
- Show the plan and elevation of the point P.

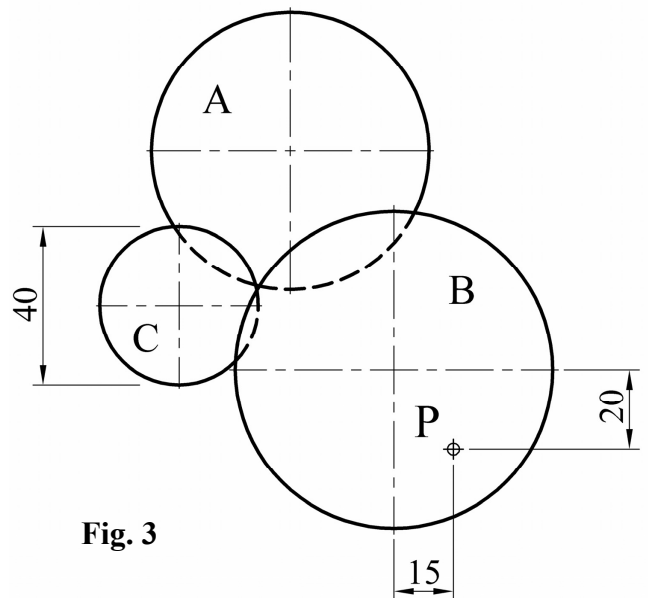
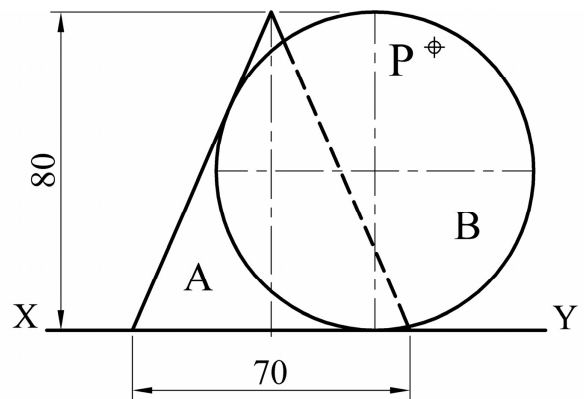

Fig. 3

4. Fig. 4 shows a circle C with a point P on its circumference. A portion of a circle D with a point Q on its circumference is in contact with the circle C as shown.

- Circle C rolls clockwise along the line AB until P reaches the line AB.

Plot the locus of P for this movement.

- Circle D rolls anticlockwise along the line AB until Q reaches the line AB.

Plot the locus of Q for this movement.

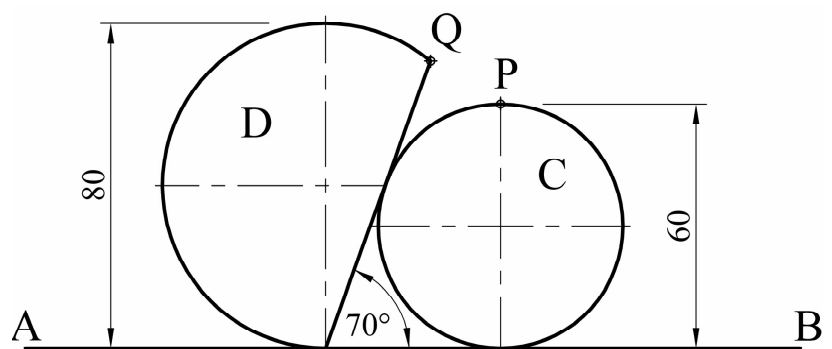

Fig. 4

5. The elevation and plan of a solid, which is to be cut by an oblique plane VTH, are shown in Fig. 5.

- (a) Draw the plan and elevation of the solid when it is cut by the oblique plane VTH.
- (b) Draw the true shape of the cut surface of the solid.

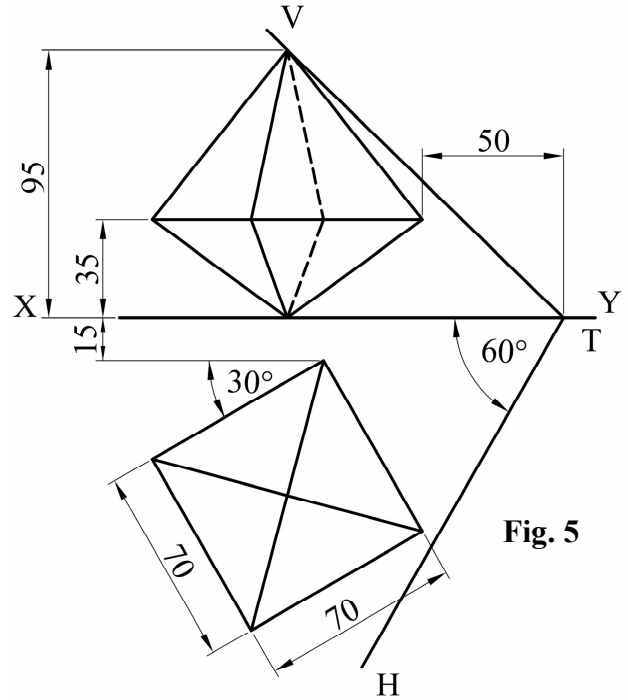

Fig. 5

6. (a) An ellipse has an eccentricity of 0.75. The distance from the focus to the directrix is 45mm. Draw the ellipse.

- (b) Fig. 6 shows the directrix of a parabola. The position of the axis is also shown. The position of a point P on the curve is also shown.

Locate the focus and vertex of the parabola.

Draw a portion of the curve which passes through the given point P.

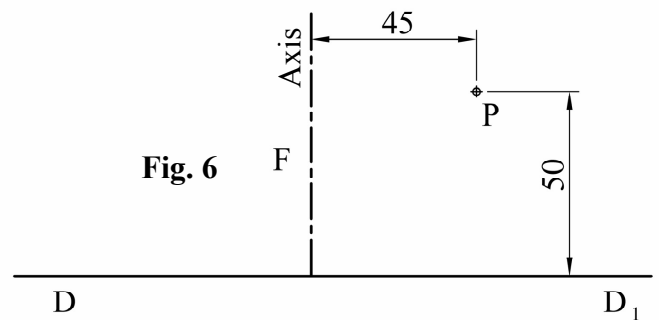

Fig. 6

7. Fig. 7 shows the plan and elevation of a rectangular based prism. It is intersected by a triangular prism.

Draw the plan, elevation and end elevation of the solids showing all lines of interpenetration.

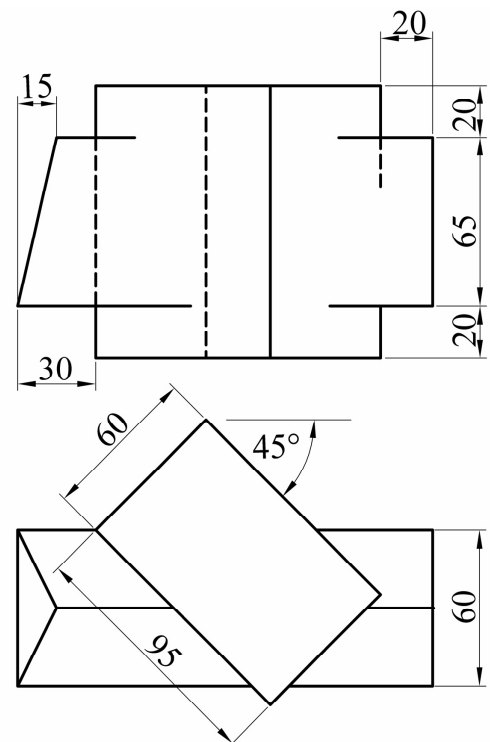

Fig. 7

BLANK PAGE

BLANK PAGE