

Coimisiún na Scrúduithe Stáit
State Examinations Commission

Leaving Certificate 2014

Marking Scheme

Mathematics
(Project Maths – Phase 3)

Foundation Level

Note to teachers and students on the use of published marking schemes

Marking schemes published by the State Examinations Commission are not intended to be standalone documents. They are an essential resource for examiners who receive training in the correct interpretation and application of the scheme. This training involves, among other things, marking samples of student work and discussing the marks awarded, so as to clarify the correct application of the scheme. The work of examiners is subsequently monitored by Advising Examiners to ensure consistent and accurate application of the marking scheme. This process is overseen by the Chief Examiner, usually assisted by a Chief Advising Examiner. The Chief Examiner is the final authority regarding whether or not the marking scheme has been correctly applied to any piece of candidate work.

Marking schemes are working documents. While a draft marking scheme is prepared in advance of the examination, the scheme is not finalised until examiners have applied it to candidates' work and the feedback from all examiners has been collated and considered in light of the full range of responses of candidates, the overall level of difficulty of the examination and the need to maintain consistency in standards from year to year. This published document contains the finalised scheme, as it was applied to all candidates' work.

In the case of marking schemes that include model solutions or answers, it should be noted that these are not intended to be exhaustive. Variations and alternatives may also be acceptable. Examiners must consider all answers on their merits, and will have consulted with their Advising Examiners when in doubt.

Future Marking Schemes

Assumptions about future marking schemes on the basis of past schemes should be avoided. While the underlying assessment principles remain the same, the details of the marking of a particular type of question may change in the context of the contribution of that question to the overall examination in a given year. The Chief Examiner in any given year has the responsibility to determine how best to ensure the fair and accurate assessment of candidates' work and to ensure consistency in the standard of the assessment from year to year. Accordingly, aspects of the structure, detail and application of the marking scheme for a particular examination are subject to change from one year to the next without notice.

Contents

Page

Paper 1

Model Solutions	3
Marking Scheme	19
Structure of the marking scheme	19
Summary of mark allocations and scales to be applied	20
Detailed marking notes	21

Paper 2

Model Solutions	29
Marking Scheme	45
Structure of the marking scheme	45
Summary of mark allocations and scales to be applied	46
Detailed marking notes	47

Marcanna breise as ucht freagairt trí Gaeilge	56
---	----



Coimisiún na Scrúduithe Stáit
State Examinations Commission

Leaving Certificate Examination 2014

Mathematics
(Project Maths – Phase 3)

Paper 1

Foundation Level

Friday 6 June Afternoon 2:00 – 4:30

300 marks

Model Solutions – Paper 1

Note: The model solutions for each question are not intended to be exhaustive – there may be other correct solutions. Any examiner unsure of the validity of the approach adopted by a particular candidate to a particular question should contact his / her advising examiner.

Instructions

There are **two** sections in this examination paper.

Section A	Concepts and Skills	200 marks	8 questions
Section B	Contexts and Applications	100 marks	2 questions

Answer all ten questions.

Write your answers in the spaces provided in this booklet. You may lose marks if you do not do so. There is space for extra work at the back of the booklet. You may also ask the superintendent for more paper. Label any extra work clearly with the question number and part.

The superintendent will give you a copy of the *Formulae and Tables* booklet. You must return it at the end of the examination. You are not allowed to bring your own copy into the examination.

You will lose marks if all necessary work is not clearly shown.

Answers should include the appropriate units of measurement, where relevant.

Answers should be given in simplest form, where relevant.

Write the make and model of your calculator(s) here:

Answer **all eight** questions from this section.

Question 1**(25 marks)**

(a) Use your calculator to answer the following.

(i) Find $\sqrt{3 \times 10^5}$, correct to the nearest whole number.

$$= \sqrt{300000} = 547.72 = 548$$

(ii) Find $\frac{\pi}{12}$, correct to one decimal place.

$$\frac{\pi}{12} = 0.2619047 = 0.3 \quad \text{or} \quad \frac{\pi}{12} = \frac{180}{12} = 15$$

(iii) Find 8% of 910, correct to the nearest whole number.

$$910 \times 0.08 = 72.8 = 73$$

(b) The population of China is 1.351×10^9 people.
Write this as a whole number of people.

$$= 1\,351\,000\,000$$

Question 2**(25 marks)**

- (a) (i) Write 125 as 5^n , where $n \in \mathbb{N}$

$$125 = 5^3$$

- (ii) Find $49^{\frac{1}{2}}$.

$$\sqrt{49} = 7$$

- (b) Simplify $\frac{(a^4)^2}{a^5}$.

$$\frac{a^8}{a^5} = a^3$$

- (c) For each of the following sequences of numbers, use the pattern to continue the sequence for two more terms:

- (i) 2, 6, 18, 54, _____, _____.

$$2, 6, 18, 54, 162, 486$$

- (ii) 1, 3, 6, 10, _____, _____.

$$1, 3, 6, 10, 15, 21$$

Question 3**(25 marks)**

- (a) (i) Write each of the numbers below correct to the nearest whole number.

$$1.8 = \boxed{2} \quad 15.2 = \boxed{15} \quad 4.9 = \boxed{5}$$

- (ii) Use your values from above to estimate the value of $\frac{1.8 \times 15.2}{4.9}$.

$$\frac{\boxed{2} \times \boxed{15}}{\boxed{5}} = \boxed{6}$$

- (iii) Use your calculator to find the actual value of $\frac{1.8 \times 15.2}{4.9}$. Give your answer correct to one decimal place.

$$\frac{1.8 \times 15.2}{4.9} = \frac{27.36}{4.9} = 5.6$$

- (b) (i) Find the difference between the actual value and your estimated value in part (a) (ii).

$$6.0 - 5.6 = 0.4$$

- (ii) Find the percentage error in your estimate. Give your answer correct to one decimal place.

$$\frac{0.4 \times 100}{5.6} = 7.142857 = 7.1\%$$

Question 4**(25 marks)**

- (a) A surveyor needed to find the area of a small piece of land, bounded in part by two straight walls $[AB]$ and $[BC]$. He divided $[AB]$ into five equal parts. Each part is 3 m long. The distance to the boundary from each part is shown in the diagram below. Use the Trapezoidal Rule to find the approximate area of the piece of land.

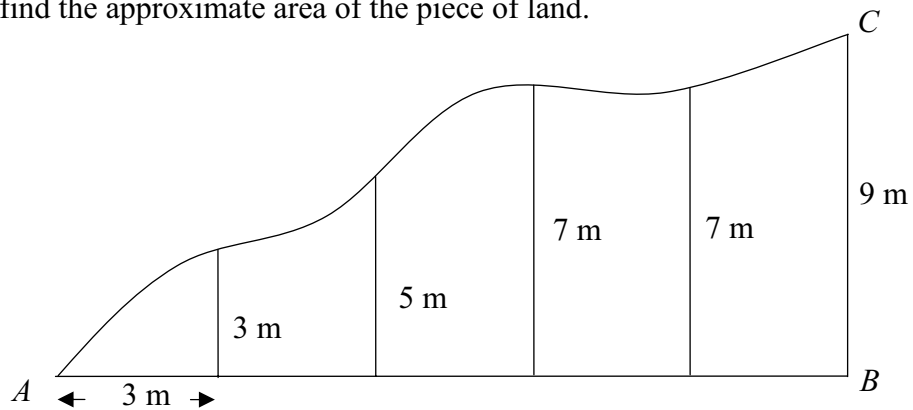

$$\begin{aligned} & \frac{3}{2}[0+9+2(3+5+7+7)] \\ &= \frac{3}{2}[53] \\ &= 79.5 \text{ m}^2 \end{aligned}$$

- (b) (i) The diagram below shows the end wall of a shed. Find the area of the end wall.

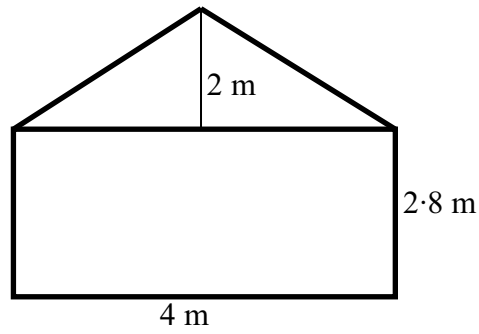

$$A = 4 \times 2.8 + \frac{1}{2} [4 \times 2]$$
$$= 15.2 \text{ m}^2$$

- (ii) The diagram below shows the shed. Find the volume of the shed.

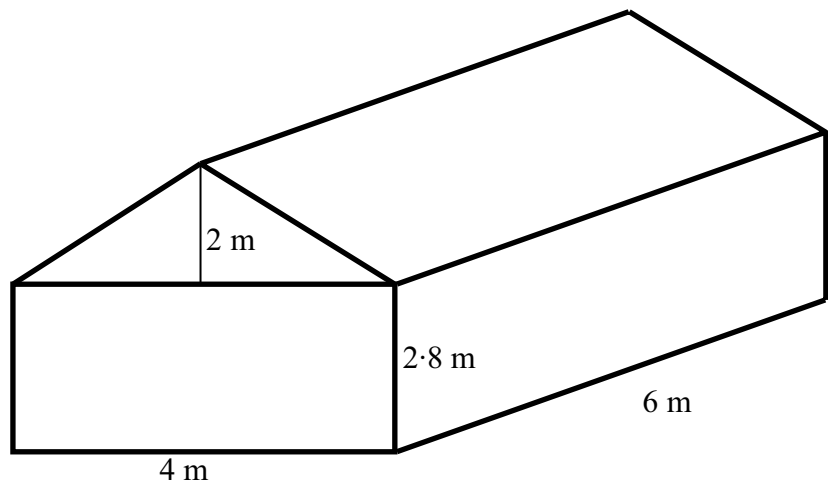

$$15.2 \times 6 = 91.2 \text{ m}^3$$

Question 5**(25 marks)****(a)** In the spaces provided, write down:**(i)** 2 natural numbers

1

and

2

(ii) 2 negative integers

-1

and

-2

(iii) 2 prime numbers

3

and

5

(b) A tractor depreciates in value at a rate of 15% per year.**(i)** Write 15% as a decimal.

0.15

(ii) The tractor was bought for €100 000. Find its value at the end of three years.

= €100 000

- €15 000

= €85 000

- €12 750

= €72 250

- €10 837.50

= €61 412.50

or

$$100\,000(0.85)^3 = €61\,412.50$$

Question 6**(25 marks)**

- (a) Find the value of $x^2 - 2x + 5$ when $x = -3$.

$$\begin{aligned} &9 - 2(-3) + 5 \\ &= 9 + 6 + 5 \\ &= 20 \end{aligned}$$

- (b) Simplify $3(5a - 1) - 4(a - 2)$.

$$\begin{aligned} &= 15a - 3 - 4a + 8 \\ &= 11a + 5 \end{aligned}$$

- (c) Solve the equation $m^2 + 2m - 5 = 0$. Give your answers correct to one decimal place.

$$\begin{aligned} x &= \frac{-2 \pm \sqrt{4 + 20}}{2} \\ &= \frac{-2 \pm \sqrt{24}}{2} \\ &= \frac{-2 \pm 4.8989}{2} \\ x &= 1.449 \quad \text{or} \quad x = -3.4495 \\ x &= 1.4 \quad \text{or} \quad x = -3.4 \end{aligned}$$

Question 7**(25 marks)**

- (a) Solve the equation $3x - 1 = 2x + 5$.

$$3x - 2x = 5 + 1$$
$$x = 6$$

- (b) Write down the natural numbers, x , which satisfy the inequality $9 - 2x > 1$.

$$9 - 1 > 2x$$
$$8 > 2x$$
$$4 > x$$
$$x < 4$$
$$\{1, 2, 3\}$$

- (c) Ruairí is x years of age.

- (i) Alex is 7 years older than Ruairí. Write down an expression in x for Alex's age.

Answer:

$$x + 7$$

- (ii) Aileen is three times as old as Ruairí. Write down an expression in x for Aileen's age.

Answer:

$$3x$$

- (iii) Aileen's age added to Alex's age is 47. How old is Ruairí?

$$3x + x + 7 = 47$$
$$4x = 40$$
$$x = 10$$

Question 8

(25 marks)

- (a) The function $f : x \mapsto 3 - 2x$ is defined for all values of $x \in R$. Find the value of $f(-3)$.

$$f(-3) = 3 - 2(-3)$$

$$f(-3) = 3 + 6$$

$$f(-3) = 9$$

- (b) The graphs of two functions are shown on the axes below. The functions are:

$$g(x) = x + 1, x \in R \quad \text{and} \quad h(x) = x^2 - 2x - 3, x \in R$$

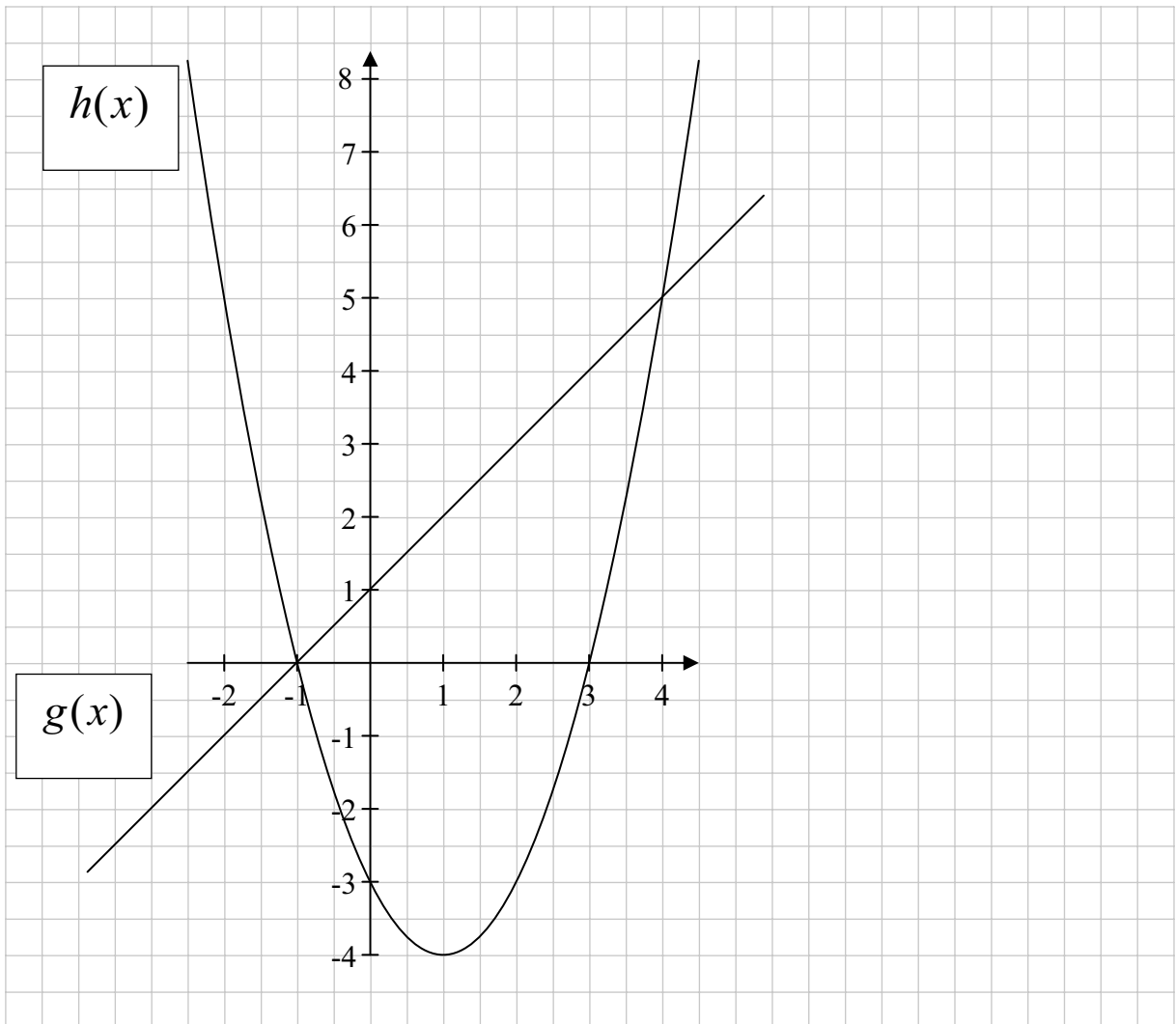

- (i) Identify the functions by writing $g(x)$ or $h(x)$ in the blank boxes on the diagram above.

Use the diagram to answer the questions below. Show your work on the diagram.

- (ii) Find the value of $h(1.5)$.

Answer:

- (iii) Find the value of x for which $g(x) = 3$.

Answer:

- (iv) Find the values of x for which $h(x) = g(x)$.

Answers: and

Answer **both** Question 9 **and** Question 10 from this section.

Question 9**(50 marks)**

(a) A pattern of rectangles is shown in the diagram below.

(i) Draw the next two rectangles in the pattern. Write the dimensions (i.e. 3×1 , 4×2 , etc.) under them.

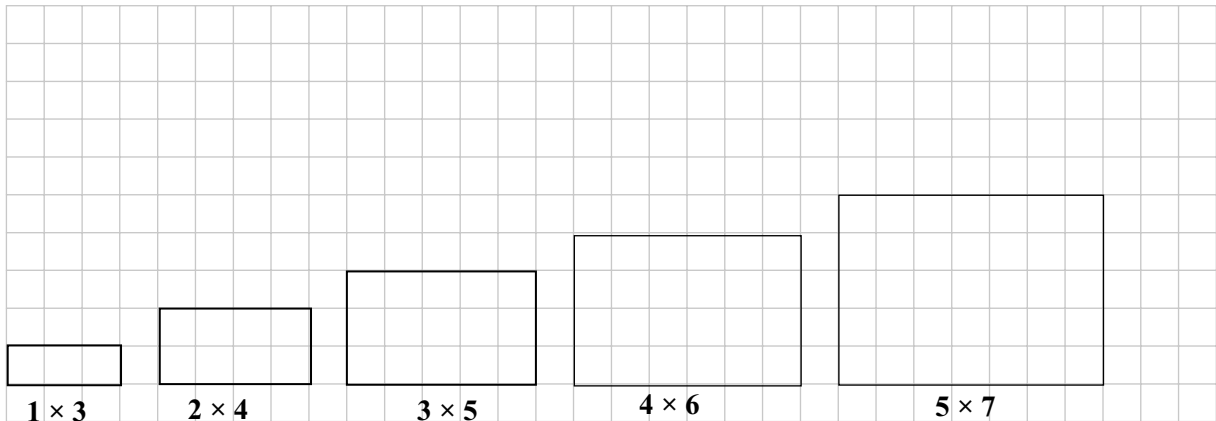

(ii) Complete the table below.

Height of rectangle	No. of small squares in the rectangle.
1	3
2	8
3	15
4	24
5	35

(iii) Plot the 5 points from your table ((1, 3), (2, 8), etc.) on the given axes.

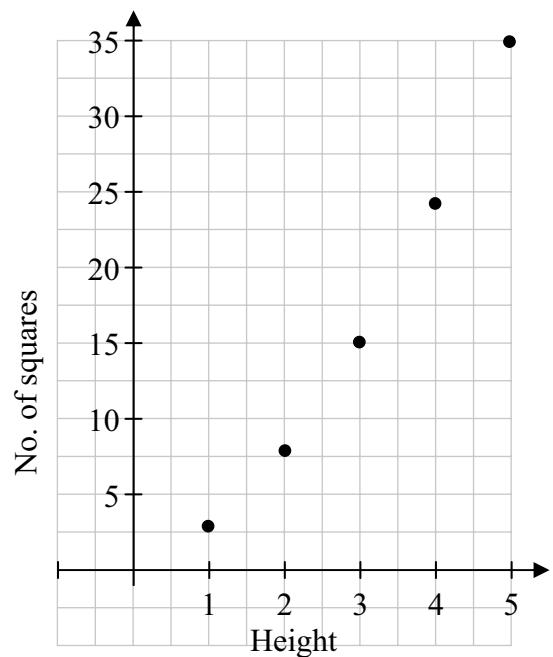

- (b) (i) The number of small squares in **each** rectangle in part (a) can be calculated by using one of the following three expressions, where h is the height of the rectangle.

$$h^2 + h$$

$$h^2 + 2$$

$$h^2 + 2h$$

Which expression always gives the correct number of small squares?

Give a reason for your answer.

Expression:	$h^2 + 2h$
	$(1)^2 + 2(1) = 3$
	$(2)^2 + 2(2) = 8$
Reason:	$(3)^2 + 2(3) = 15$
	$(4)^2 + 2(4) = 24$
	$(5)^2 + 2(5) = 25$

- (ii) For each of the 5 rectangles above, shade in the biggest possible square that fits into that rectangle.

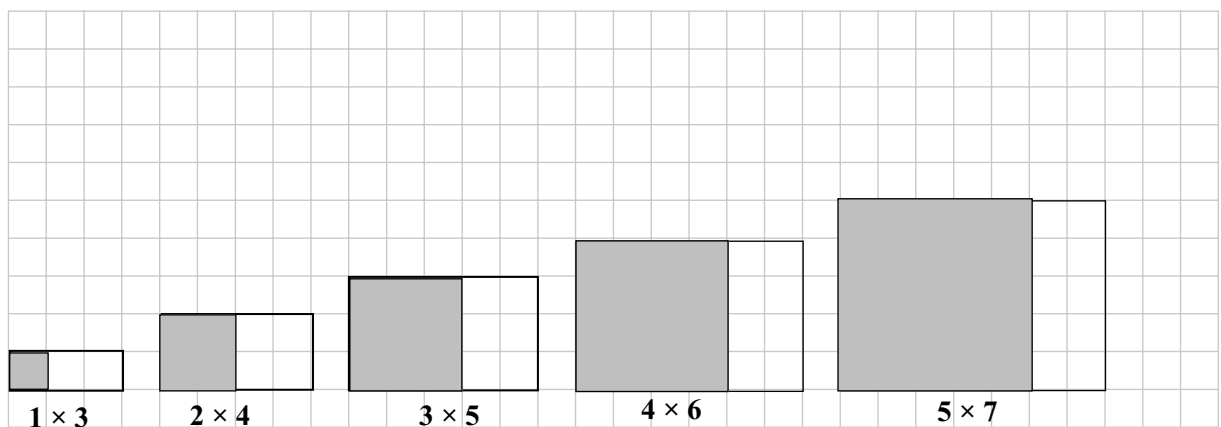

- (iii) For each of the 5 rectangles, write down the numbers of small squares that are **not** shaded.

2, 4, 6, 8, 10

- (iv) Is there a pattern to be seen in the numbers in your answer to (iii) above? Give a reason for your answer.

Answer: Yes
Reason: Pattern is $2n$

Question 10

(50 marks)

The chart below shows the distances (in kilometres) between some of Ireland’s main towns. For example, the distance between Portlaoise and Galway is 150 km and the distance between Sligo and Belfast is 206 km (highlighted in the chart).

Distance Chart (km)

										Athlone
										Belfast
										224
									Cork	423
									Derry	428
								Dublin	237	257
								Galway	219	272
								Kilkenny	172	117
								Limerick	113	105
								Mullingar	145	117
								Portlaoise	109	114
								Sligo	191	137
								Waterford	293	100
									164	129
									48	220
									158	383
									126	333
									282	174
									84	253
									217	135
									138	217
									245	135
									50	84
									114	282
									114	174
									50	253
									117	74
									117	206
									126	117
									126	174

Use the chart to answer the following questions.

- (a) (i) What is the distance between Sligo and Dublin? Answer: 217 km
- (ii) Carla has to go from Sligo to Dublin. She travels from Sligo to Portlaoise first and then on to Dublin. How many kilometres does this add to her journey?

191+84=275 km
275-217 = 58 km

- (b) Which two towns, shown in the chart, are furthest apart?
Answer: Derry and Cork

- (c) Amanda travelled from Waterford to Belfast. The graph below shows the 5 stages of her journey.

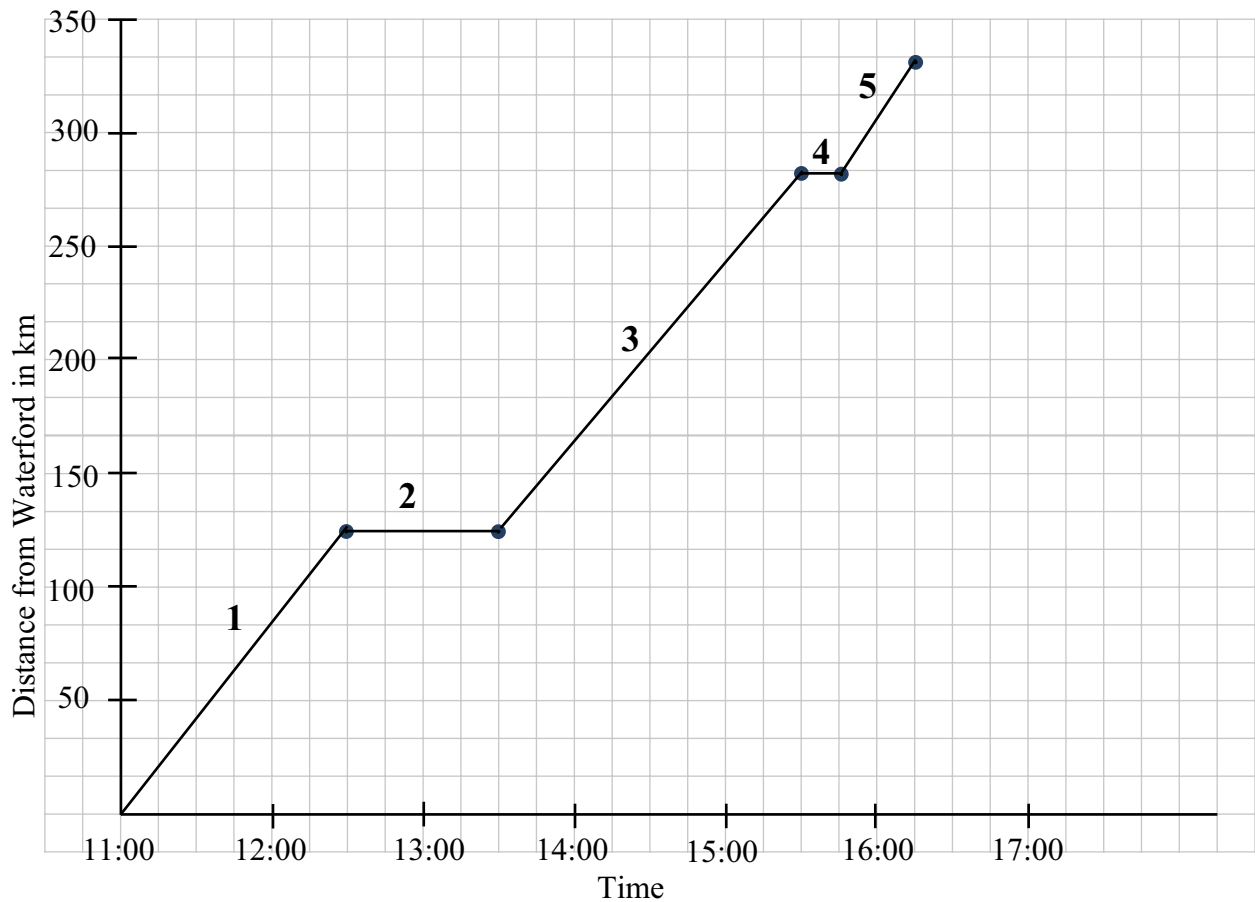

The stages of the journey are labelled 1, 2, 3, 4, and 5 on the graph.

There are five statements below, labelled with letters A, B, C, D, and E.

- A. She takes about 15 minutes to change the wheel.
- B. She drives steadily and arrives in Belfast around 16:15.
- C. She stops for lunch for about an hour.
- D. She sets out from Waterford at 11:00 and drives at a steady speed until lunchtime.
- E. She drives steadily for about 2 hours.

In the table below, insert the letters A, B, C, D, and E to match each one of the statements above with a stage of her journey.

Stages of her journey	Statement
1	D
2	C
3	E
4	A
5	B

- (d) (i) How long, in total, did it take Amanda to travel from Waterford to Belfast?

5 Hours 15 Min

- (ii) Find Amanda's average speed during her trip, in kilometres per hour. Give your answer correct to the nearest whole number.

$$\text{Av. Speed} = \frac{333}{5.25} = 63.4 = 63 \text{ km/h}$$

- (e) The car was stopped for a total of one hour and fifteen minutes. Find the amount of time the car was being driven during the journey.

$$5:15 - 1:15 = 4 \text{ hours}$$

- (f) Amanda changed some euro into sterling. She got £215. The exchange rate was €1 = £0.86. How much did she have to pay, in euro?

$$\text{Euro} = \frac{215}{0.86} = \text{€}250$$

Marking Scheme – Paper 1, Section A and Section B

Structure of the marking scheme

Candidate responses are marked according to different scales, depending on the types of response anticipated. Scales labelled A divide candidate responses into two categories (correct and incorrect). Scales labelled B divide responses into three categories (correct, partially correct, and incorrect), and so on. The scales and the marks that they generate are summarised in this table:

Scale label	A	B	C	D	E
No of categories	2	3	4	5	6
5 mark scales	0, 5	0, 2, 5	0, 2, 3, 5		
10 mark scales	0, 10	0, 5, 10	0, 3, 7, 10	0, 2, 5, 8, 10	
15 mark scales	0, 15	0, 7, 15	0, 5, 10, 15	0, 4, 7, 11, 15	

A general descriptor of each point on each scale is given below. More specific directions in relation to interpreting the scales in the context of each question are given in the scheme, where necessary.

Marking scales – level descriptors

A-scales (two categories)

- incorrect response
- correct response

B-scales (three categories)

- response of no substantial merit
- partially correct response
- correct response

C-scales (four categories)

- response of no substantial merit
- response with some merit
- almost correct response
- correct response

D-scales (five categories)

- response of no substantial merit
- response with some merit
- response about half-right
- almost correct response
- correct response

E-scales (six categories)

- response of no substantial merit
- response with some merit
- response almost half-right
- response more than half-right
- almost correct response
- correct response

In certain cases, typically involving incorrect rounding, omission of units, a misreading that does not oversimplify the work or an arithmetical error that does not oversimplify the work, a mark that is one mark below the full-credit mark may also be awarded. Thus, for example, in *scale 10C*, 9 marks may be awarded.

Summary of mark allocations and scales to be applied

Section A

Question 1	
(a)(i)(ii)	10C
(a)(iii)	10B
(b)	5B
Question 2	
(a)	10C
(b)	5B
(c)	10C
Question 3	
(a)	15D
(b)	10C
Question 4	
(a)	10C
(b)	15C
Question 5	
(a)	10D
(b)	15C
Question 6	
(a)	10B
(b)	10C
(c)	5B
Question 7	
(a)	15C
(b)	5B
(c)	5C
Question 8	
(a)	5B
(b)(i)	5B
(b)(ii)	5B
(b)(iii)	5B
(b)(iv)	5B

Section B

Question 9	
(a)(i)	10C
(a)(ii)	10C
(a)(iii)	10D
(b)(i)	5C
(b)(ii)	5B
(b)(iii)	5B
(b)(iv)	5B
Question 10	
(a)	10C
(b)	10B
(c)	10D
(d)	10C
(e)	5B
(f)	5B

Detailed marking notes

Section A

Question 1

(a)(i), (ii) Scale 10C (0,3,7, 10)

Low Partial Credit

- Any work of merit in one part

High Partial Credit

- One correct answer
- Some work of merit in both parts

(a)(iii) Scale 10B (0,5, 10)

Partial Credit

- Any work of merit

(b) Scale 5B (0,2, 5)

Partial Credit

- Any work of merit

Question 2

(a) Scale 10C (0, 3, 7, 10)

Low Partial Credit

- Any work of merit in one part

High Partial Credit

- One correct answer
- Some work of merit in both parts

(b) Scale 5B (0, 2, 5)

Partial Credit

- Any work of merit

(c) Scale 10C (0, 3, 7, 10)

Low Partial Credit

- Any work of merit in one part

High Partial Credit

- Part (i) or part (ii) fully correct
- Some work of merit in both parts

Question 3

(a) Scale 15D (0, 4, 7, 11, 15)

Low Partial Credit

- Any work of merit in one part

Mid Partial Credit

- Part (i), (ii) or (iii) fully correct
- Any work of merit in two parts

High Partial Credit

- Two parts fully correct
- Some work of merit in all three parts.

Note: Accept the use of candidates answer from (a)(i) in answering (a)(ii)

(b) Scale 10C (0, 3, 7, 10)

Low Partial Credit

- Any work of merit in one part

High Partial Credit

- One correct answer
- Some work of merit in both parts

Note: Accept the use of candidates answers from parts (a)(ii) and (a)(iii)

Question 4

(a) Scale 10C (0, 3, 7, 10)

Low Partial Credit

- Any work of merit

High Partial Credit

- Correct substitution into formula and fails to finish.
- One error in substitution into formula and finishes correctly.

(b) Scale 15C (0, 5, 10, 15)

Low Partial Credit

- Any work of merit in one part

High Partial Credit

- One correct answer.
- Some work of merit in both parts.

Note: Accept the use of candidates answer from part (i) when answering part (ii)

Question 5

(a) Scale 10D (0, 2, 5, 8, 10)

Low Partial Credit

- One correct entry

Mid Partial Credit

- Two or three correct entries

High Partial Credit

- Four or five correct entries

(b) Scale 15C (0, 5, 10, 15)

Low Partial Credit

- Any work of merit in one part

High Partial Credit

- One part correct
- Some work of merit in both parts

Note: Accept the use of candidates answer from part (i) when answering part (ii)

Question 6

(a) Scale 10B (0, 5, 10)

Partial Credit

- Any work of merit

(b) Scale 10C (0, 3, 7, 10)

Low Partial Credit

- Any work of merit

High Partial Credit

- Multiplies out correctly but fails to finish.

(c) Scale 5B (0, 2, 5)

Partial Credit

- Any work of merit

Question 7

- (a) Scale 15C (0,5, 10, 15)
Low Partial Credit
- Any work of merit
 - Attempt to solve equation by trial and improvement
- High Partial Credit*
- Correct method but with one consistent error
- Full Credit*
- Correct solution verified by trial and improvement
- (b) Scale 5B (0, 2, 5)
Partial Credit
- Any work of merit
- (c) Scale 5C (0, 2, 3, 5)
Low Partial Credit
- One correct answer
 - Work of merit in one part
- High Partial Credit*
- Two correct answer
 - Work of merit in two or three parts

Note : Accept candidates answers to (c)(i) and (c)(ii) if used in (c)(iii)

Question 8

- (a)** Scale 5B (0, 2, 5)
Partial Credit
 - Any work of merit
- (b)(i)** Scale 5B (0, 2, 5)
Partial Credit
 - Any work of merit
- (b)(ii)** Scale 5B (0, 2, 5)
Partial Credit
 - Any work of merit
- (b)(iii)** Scale 5B (0, 2, 5)
Partial Credit
 - Any work of merit
- (b)(iv)** Scale 5B (0, 2, 5)
Partial Credit
 - Any work of merit

Section B

Question 9

(a)(i) Scale 10C (0, 3, 7, 10)

Low Partial Credit

- One correct rectangle drawn
- One correct set of dimensions

High Partial Credit

- Two correct sets of dimensions given
- Two correct rectangles drawn
- One correct rectangle drawn with a correct set of dimensions

(a)(ii) Scale 10C (0, 3, 7, 10)

Low Partial Credit

- One correct answer
- Any work of merit

High Partial Credit

- Two correct answers

(a)(iii) Scale 10D (0, 2, 5, 8, 10)

Low Partial Credit

- One point plotted correctly
- Any work of merit

Mid Partial Credit

- Two or three points plotted correctly

High Partial Credit

- Four points plotted correctly

(b)(i) Scale 5C (0, 2, 3, 5)

Low Partial Credit

- Any work of merit

High Partial Credit

- Correct expression without a reason

(b)(ii) Scale 5B (0, 2, 5)

Partial Credit

- Any work of merit

(b)(iii) Scale 5B (0, 2, 5)

Partial Credit

- Any work of merit

(b)(iv) Scale 5B (0, 2, 5)

Partial Credit

- Any work of merit

Note: Accept candidates answers from previous parts when correcting this question

Question 10

- (a) Scale 10C (0, 3, 7, 10)
Low Partial Credit
- Any work of merit in one part
- High Partial Credit*
- One correct answer
 - Some work of merit in both parts
 -
- (b) Scale 10B (0, 5, 10)
Partial Credit
- One town correct
 - Any work of merit
- (c) Scale 10D (0, 2, 5, 8, 10)
Low Partial Credit
- One correct answer
- Mid Partial Credit*
- Two or three correct answers
- High Partial Credit*
- Four correct answers
- (d) Scale 10C (0, 3, 7, 10)
Low Partial Credit
- Any work of merit in one part
- High Partial Credit*
- One correct answer
 - Some work of merit in both parts
- (e) Scale 5B (0, 2, 5)
Partial Credit
- Any work of merit
- (f) Scale 5B (0, 2, 5)
Partial Credit
- Any work of merit



Coimisiún na Scrúduithe Stáit
State Examinations Commission

Leaving Certificate Examination 2014

Mathematics

(Project Maths – Phase 3)

Paper 2

Foundation Level

Monday 9 June Morning 9:30 – 12:00

300 marks

Model Solutions – Paper 2

Note: The model solutions for each question are not intended to be exhaustive – there may be other correct solutions. Any examiner unsure of the validity of the approach adopted by a particular candidate to a particular question should contact his / her advising examiner.

Instructions

There are **two** sections in this examination paper.

Section A	Concepts and Skills	200 marks	8 questions
Section B	Contexts and Applications	100 marks	2 questions

Answer all ten questions, as follows:

In Section A, answer

Questions 1 to 7 and

either Question 8A **or** Question 8B.

In Section B, answer Question 9 and Question 10.

Write your answers in the spaces provided in this booklet. You may lose marks if you do not do so. There is space for extra work at the back of the booklet. You may also ask the superintendent for more paper. Label any extra work clearly with the question number and part.

The superintendent will give you a copy of the *Formulae and Tables* booklet. You must return it at the end of the examination. You are not allowed to bring your own copy into the examination.

You will lose marks if all necessary work is not clearly shown.

Answers should include the appropriate units of measurement, where relevant.

Answers should be given in simplest form, where relevant.

Write the make and model of your calculator(s) here:

Answer **all eight** questions from this section.

Question 1**(25 marks)**

- (a) In an experiment, a number is chosen at random from the set of numbers $\{2, 3, 4, 5, 6, 7, 8, 10, 12, 14, 28, 30\}$.

Some possible outcomes are listed in the table below.

Find the probability of each outcome and write your answers in the table.

Outcome	Probability
The number is odd.	$\frac{1}{4}$
The number is even.	$\frac{3}{4}$
The number is 25.	$\frac{0}{12}$
The number is less than 8.	$\frac{1}{2}$

- (b) Mary surveyed 150 students to find which social networking sites they use. Some of the results are shown in the Venn diagram below.

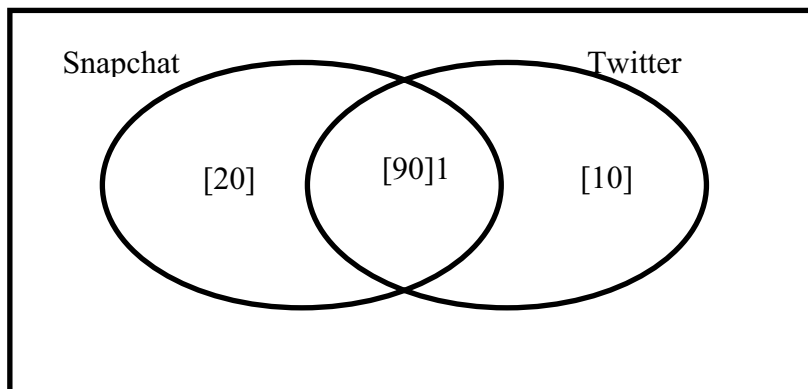

- (i) Find the number of students who used neither of the two sites.

$$150 - 120 = 30$$

- (ii) One student is chosen at random from those surveyed. Find the probability that the student used both sites.

$$\frac{90}{150} = \frac{9}{15} = \frac{3}{5}$$

Question 2

(25 marks)

- (a) A fair spinner has four equal sectors, Red, Green, Yellow, and Blue. The spinner is spun.

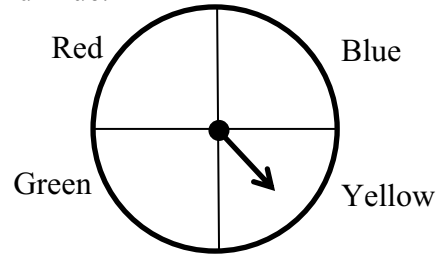

- (i) What is the probability it stops on the yellow sector?

$\frac{1}{4}$

- (ii) What is the probability it stops on the red or the green sector?

$\frac{1}{2}$

- (iii) What is the probability it stops on any colour except blue?

$\frac{3}{4}$

- (b) Joe plays a game with four coloured cards and a fair die. Each card is a different colour, as shown.

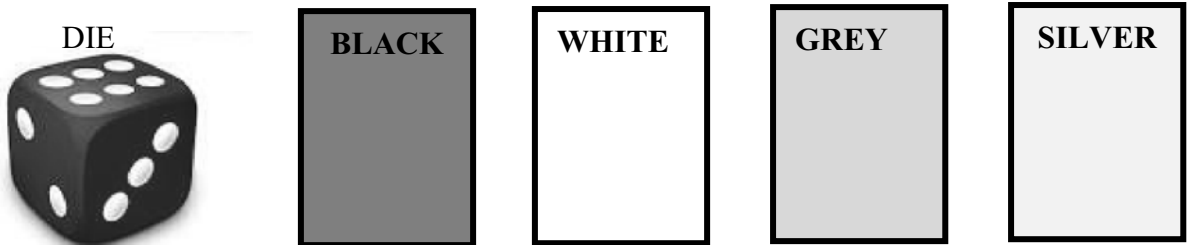

Joe picks a card at random and rolls the die. The table below shows some of the possible outcomes.

- (i) Complete the table below.

	1	2	3	4	5	6
Black	B, 1	B,2	B,3	B,4	B,5	B,6
White	W,1	W,2	W,3	W,4	W, 5	W,6
Grey	G,1	G, 2	G,3	G,4	G,5	G,6
Silver	S,1	S,2	S,3	S,4	S,5	S,6

Find the probability that Joe will get:

(ii) A black card and a 6

$$\frac{1}{24}$$

(iii) A white or a grey card, and a 5

$$\frac{2}{24} = \frac{1}{12}$$

(iv) A silver card and an even number.

$$\frac{3}{24} = \frac{1}{8}$$

Question 4**(25 marks)**

$P(3, -4)$ and $Q(-2, 0)$ are two points.

- (a) Find the slope of the line PQ .

$$m = \frac{0 - (-4)}{-2 - 3} = \frac{4}{-5} = -\frac{4}{5}$$

- (b) Find the equation of the line PQ .

$$\begin{aligned}y - (-4) &= -\frac{4}{5}(x - 3) \\5y + 20 &= -4x + 12 \\4x + 5y + 8 &= 0\end{aligned}$$

- (c) A line l passes through the point $(7, 5)$ and is parallel to PQ . Find the equation of l .

$$\begin{aligned}y - 5 &= -\frac{4}{5}(x - 7) \\5y - 25 &= -4x + 28 \\4x + 5y &= 53\end{aligned}$$

Question 5**(25 marks)**

- (a) Plot the points $A(4, 6)$, $B(1, 2)$ and $C(7, 2)$ on the co-ordinate plane below. Label each point clearly.

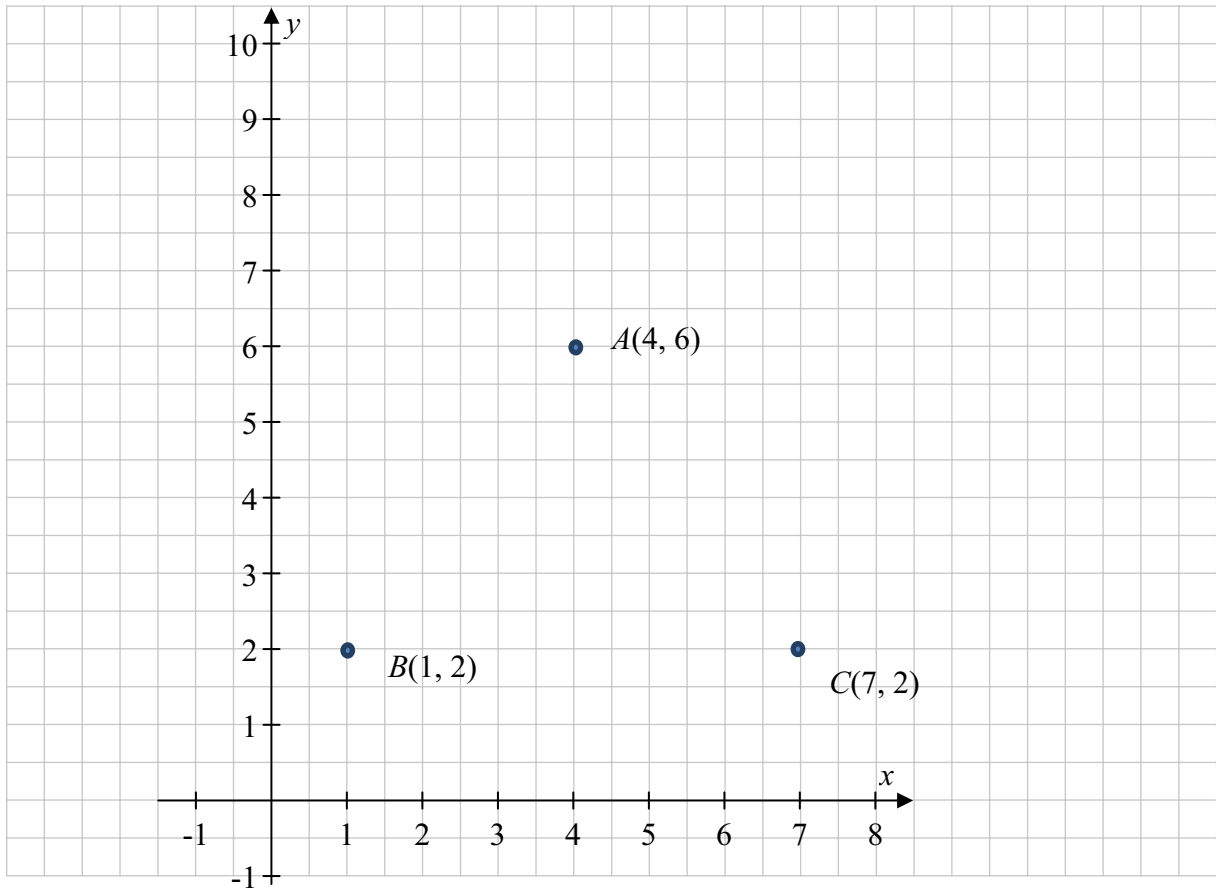

- (b) Find the mid-point of $[BC]$.

$$\text{Midpoint } [BC] = \left(\frac{1+7}{2}, \frac{2+2}{2} \right) = (4, 2)$$

- (c) (i) Find $|BC|$, the distance from B to C .

Answer: $\underline{\quad 7 - 1 = 6 \quad}$

- (ii) Use the distance formula to find $|AB|$.

$$\begin{aligned} |AB| &= \sqrt{(4-1)^2 + (6-2)^2} \\ |AB| &= \sqrt{9+16} = \sqrt{25} = 5 \end{aligned}$$

Question 6**(25 marks)**

Jack recorded the different things he did during a 24 hour period. He displayed the information in the following pie chart.

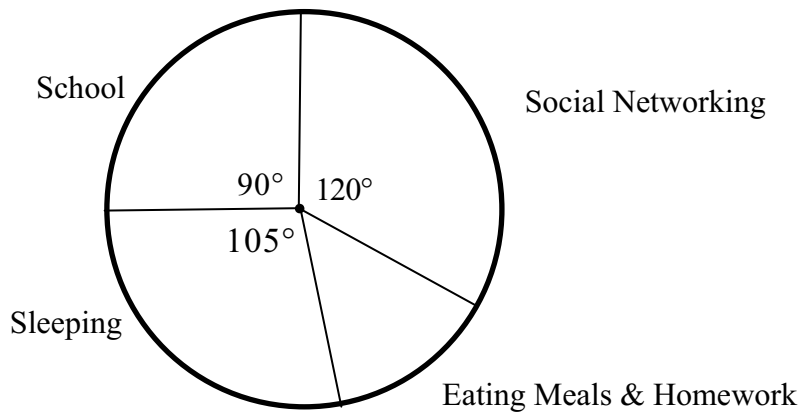

- (a) Which activity did Jack spend the most time on?

Social Networking

- (b) Find the size of the angle for 'Eating Meals & Homework'.

$$360^\circ - 315^\circ = 45^\circ$$

- (c) How long did Jack spend eating meals and doing his homework?

$$\frac{24}{8} = 3 \text{ hours}$$

- (d) 40% of the time he spent eating meals and doing his homework was spent eating. Find how long he spent at his homework.

$$3 \times 0.6 = 1.8 \text{ hours} \quad \text{or} \quad 1 \text{ h } 48 \text{ m}$$

Question 7**(25 marks)**

David is speaking at a conference. He wishes to project images from his laptop onto a large screen. The dimensions of his laptop screen are 34.5 cm by 19.3 cm.

The enlargement of David's images will fill the large screen exactly. The scale factor of the enlargement is 5.



- (a) Find the width of the large screen.

$$34.5 \times 5 = 172.5 \text{ cm}$$

- (b) Find the height of the large screen.

$$19.3 \times 5 = 96.5 \text{ cm}$$

- (c) Find the area of the large screen.

$$96.5 \times 172.5 = 16646.25 \text{ cm}^2$$

- (d) Find the area of David's laptop screen.

$$A = \frac{16646.25}{25} = 665.85 \text{ cm}^2 \quad \text{or} \quad A = 34.5 \times 19.3 = 665.85 \text{ cm}^2$$

- (e) Find the ratio, area of the large screen : area of David's laptop screen.

$$\frac{16646.25}{665.85} \quad \text{or} \quad \frac{25}{1} \quad \text{or} \quad 25:1$$

Question 8

(25 marks)

Answer **either** 8A **or** 8B.

Question 8A

(a) In the diagram below, construct a tangent to the circle at the point A .

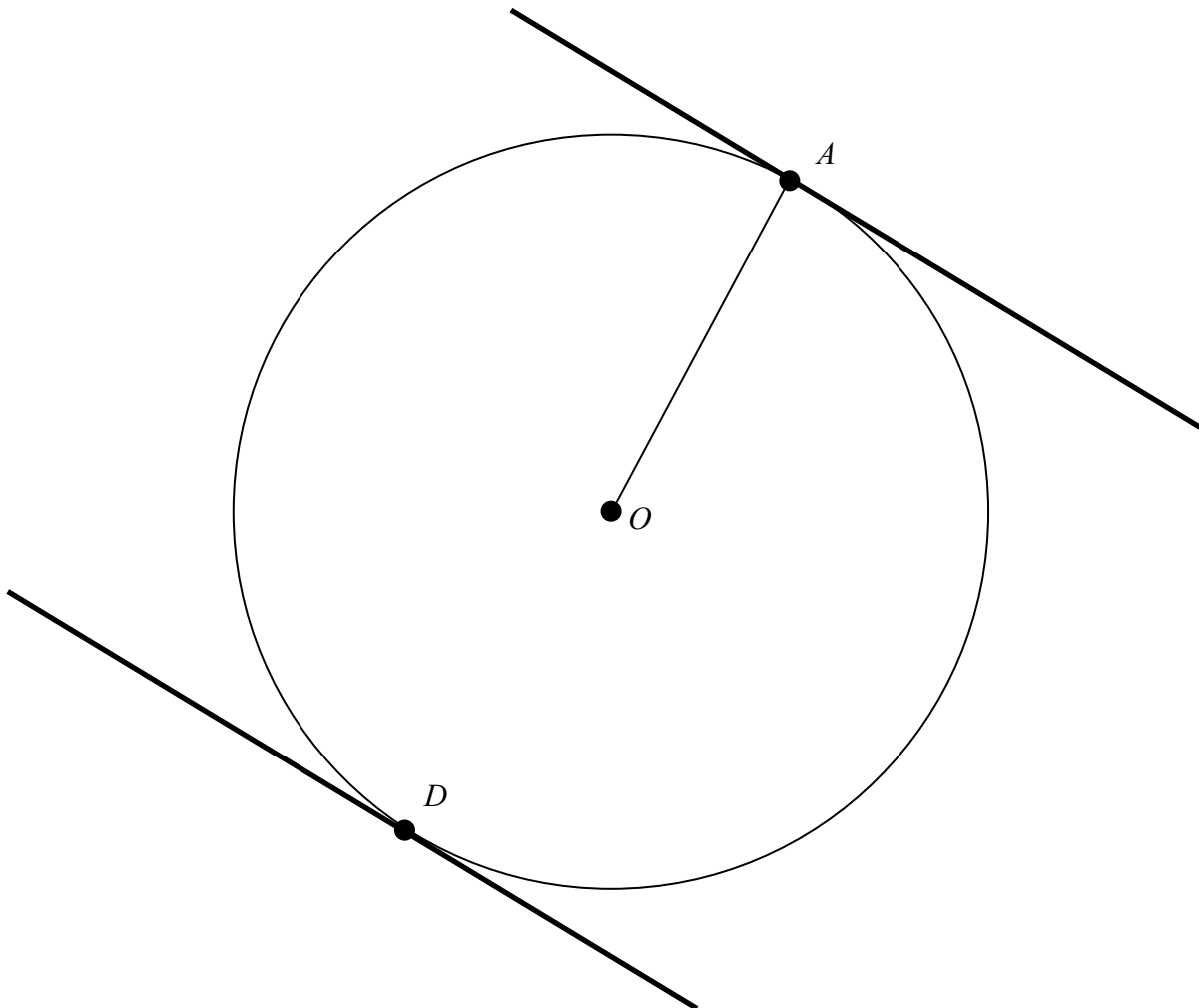

(b) The slope of the tangent at A is multiplied by the slope of the radius $[OA]$.
Write down the result.

-1

(c) A second tangent is drawn to the circle at the point D . This line is parallel to the tangent at A .
Mark the point D on the circle.

OR

Question 8B

ABC is a right-angled triangle, with $|\angle BAC| = 90^\circ$.

A circle of centre O passes through the points A , B and C , as shown.

$|AB| = 6$ cm and $|AC| = 8$ cm.

$[BC]$ is a diameter of the circle.

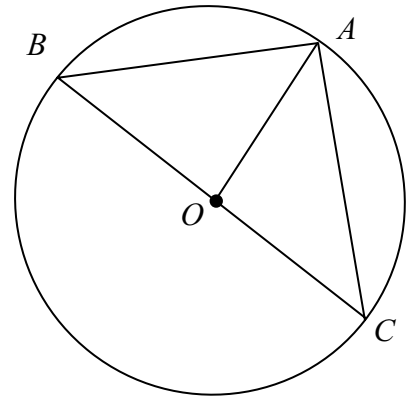

(a) Find $|BC|$.

$$|BC|^2 = 6^2 + 8^2$$

$$|BC|^2 = 36 + 64 = 100$$

$$|BC| = 10 \text{ cm}$$

(b) What is the length of $[OA]$?

$$\text{Radius} = |OA| = 5 \text{ cm}$$

(c) (i) Identify two isosceles triangles from the diagram.

$\triangle OAB$ and $\triangle OAC$

(ii) Given that $|\angle AOC| = 106^\circ$, to the nearest degree, find the following:

$$|\angle AOB| =$$

74°

$$|\angle OBA| =$$

53°

Answer **both** Question 9 **and** Question 10 from this section.

Question 9**(50 marks)**

- (a) The mean monthly midday temperatures at Malin Head in 2013 are shown in the following table. The temperature is measured in degrees Celsius.

Table 1 (Mean temperature)												
Year	Jan	Feb	Mar	Apr	May	Jun	July	Aug	Sep	Oct	Nov	Dec
2013	7	8	9	7	10	12	13	16	13	8	7	8

- (i) Which month had the highest mean temperature? Aug
- (ii) Find the difference between the highest mean temperature and the lowest mean temperature.

$$16 - 7 = 9^{\circ}$$

- (iii) Find the mean annual midday temperature at Malin Head for 2013, correct to one decimal place.

$$\frac{118}{12} = 9.833 = 9.8^{\circ}$$

- (b) Rita owns a caravan park at Malin Head. She recorded the number of children who stayed in each caravan in her park on a Friday night in August 2013. The results are shown below.

3	2	0	4	2
5	3	4	1	7
3	5	2	5	1
6	4	7	6	1
3	5	7	1	2
0	4	2	3	5

- (i) How many caravans did she survey? Answer: 30

(ii) Complete the following table.

Table 2								
Number of children per caravan	0	1	2	3	4	5	6	7
Number of caravans	2	4	5	5	4	5	2	3

(iii) How many children were in the park on that night?

$$0 + 4 + 10 + 15 + 16 + 25 + 12 + 21 = 103$$

(iv) Represent the data in Table 2 using a suitable chart.

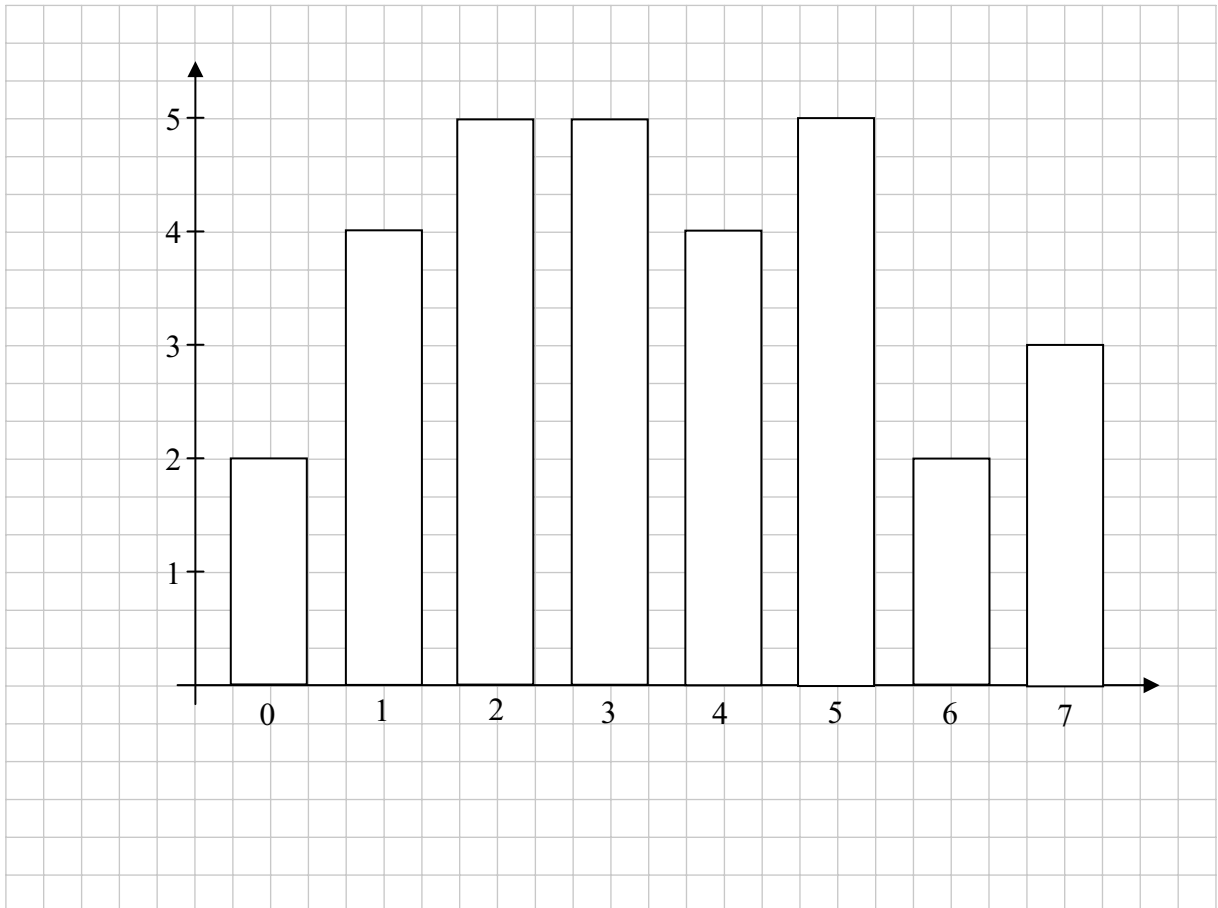

Question 10**(50 marks)**

Sean is installing a flight of stairs in a new house. The height from the floor to the top of the stairs is 2.5 m. The distance from the foot of the stairs to the wall is 3 m, as shown.

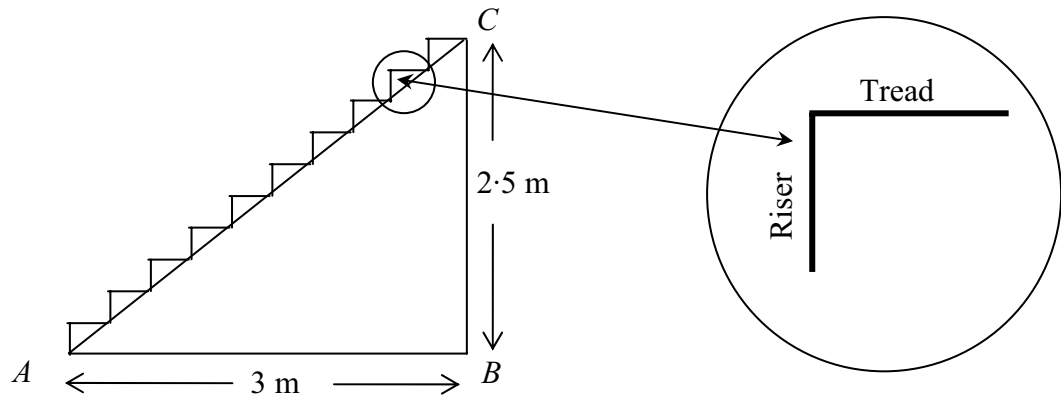

- (a) (i) Find $|AC|$, the length of the stairs, correct to one decimal place.

$$|AC|^2 = 3^2 + 2.5^2$$

$$|AC|^2 = 9 + 6.25 = 15.25$$

$$|AC| = 3.9 \text{ m}$$

- (ii) There are 10 steps on the stairs. Find the height of each riser, in metres.

$$\frac{2.5}{10} = 0.25 \text{ m}$$

- (iii) There are 10 steps on the stairs. Find the depth of each tread, in metres.

$$\frac{3}{10} = 0.3 \text{ m}$$

- (iv) The stairs are 1 m wide. Find the total area of wood required to build the steps of the stairs.

$$1 \text{ step} = 0.25 \times 1 + 0.3 \times 1 = 0.55 \text{ m}^2$$

$$10 \text{ steps} = 0.55 \times 10 = 5.5 \text{ m}^2$$

- (v) The wood to build the stairs costs €120 per square metre. Find the total cost of the wood needed to make the stairs.

$$120 \times 5.5 = \text{€}660$$

- (b) (i) Sean wants to make a storage area under the stairs. He closes the space under the stairs with a triangular sheet of plywood. Find the area of the triangle ABC .

$$A = \frac{1}{2}(3)(2.5) = 3.75 \text{ m}^2$$

- (ii) Find $|\angle CAB|$, the angle between the floor and the stairs, correct to the nearest degree.

$$\begin{aligned}\tan |\angle CAB| &= \frac{2.5}{3} \\ |\angle CAB| &= 39.8^\circ = 40^\circ\end{aligned}$$

Marking Scheme – Paper 1, Section A and Section B

Structure of the marking scheme

Candidate responses are marked according to different scales, depending on the types of response anticipated. Scales labelled A divide candidate responses into two categories (correct and incorrect). Scales labelled B divide responses into three categories (correct, partially correct, and incorrect), and so on. The scales and the marks that they generate are summarised in this table:

Scale label	B	C	D
No of categories	3	4	5
5 mark scales	0, 2, 5	0, 2, 4, 5	0, 2, 3, 4, 5
10 mark scales	0, 5, 10	0, 5, 7, 10	0, 3, 5, 8, 10
15 mark scales	0, 7, 15	0, 5, 10, 15	0, 4, 7, 11, 15

A general descriptor of each point on each scale is given below. More specific directions in relation to interpreting the scales in the context of each question are given in the scheme, where necessary.

Marking scales – level descriptors

B-scales (three categories)

- response of no substantial merit (no credit)
- partially correct response (partial credit)
- correct response (full credit)

C-scales (four categories)

- response of no substantial merit (no credit)
- response with some merit (low partial credit)
- almost correct response (high partial credit)
- correct response (full credit)

D-scales (five categories)

- response of no substantial merit (no credit)
- response with some merit (low partial credit)
- response about half-right (middle partial credit)
- almost correct response (high partial credit)
- correct response (full credit)

In certain cases, typically involving incorrect rounding, omission of units, a misreading that does not oversimplify the work or an arithmetical error that does not oversimplify the work, a mark that is one mark below the full-credit mark may also be awarded. Thus, for example, in scale 10C, 9 marks may be awarded.

Summary of mark allocations and scales to be applied

Section A

Question 1	
(a)	10D
(b) (i)	10C
(b) (ii)	5C

Question 2	
(a) (i)	5C
(a) (ii)	5C
(a) (iii)	5C
(b) (i)	5D
(b) (ii)(iii)(iv)	5C

Question 3	
(a)	10C
(b)	5C
(c)	10C

Question 4	
(a)	10C
(b)	10C
(c)	5C

Question 5	
(a)	10D
(b)	5C
(c) (i)	5C
(c) (ii)	5C

Question 6	
(a)	10B
(b)	5C
(c)	5C
(d)	5C

Question 7	
(a)	5C
(b)	5C
(c)	5C
(d)	5C
(e)	5C

Question 8A	
(a)	10B
(b)	5B
(c)	10C

Question 8B	
(a)	5C
(b)	5B
(c) (i)	10C
(c) (ii)	5C

Section B

Question 9	
(a) (i)	10B
(a) (ii)	5C
(a) (iii)	10D
(b) (i)	5B
(b) (ii)	10D
(b) (iii)	5C
(b) (iv)	5C

Question 10	
(a) (i)	10C
(a) (ii)	5C
(a) (iii)	5C
(a) (iv)	5C
(a) (v)	10C
(b) (i)	10C
(b) (ii)	5C

Detailed marking notes

Section A

Question 1

- (a) Scale 10D
Low partial credit
One correct answer or relevant work
- Middle partial credit*
Two correct answers
- High partial credit:*
Three correct answers
- (b) (i) Scale 10C
Low partial credit:
Any work of merit
- High partial credit:*
Calculates number of students who use either of two sites
- (ii) Scale 5C
Low partial credit:
Any work of merit
- High partial credit:*
Correct numerator or correct denominator
Inverted fraction

Question 2

- (a) (i) Scale 5C
Low partial credit:
Any work of merit
- High partial credit:*
Correct numerator or correct denominator
Inverted fraction
- (ii) Scale 5C
Low partial credit:
Any work of merit
- High partial credit:*
Correct numerator or correct denominator
Inverted fraction
- (iii) Scale 5C
High partial credit:
Correct numerator or correct denominator
Inverted fraction
- Low partial credit:*
Any work of merit
- (b) (i) Scale 5D
High partial credit:
At least fifteen correct entries
- Middle partial credit*
At least ten correct entries
- Low partial credit:*
One correct entry or relevant work
- (ii)(iii)(iv) Scale 5C
High partial credit:
One correct answer
- Low partial credit:*
Any work of merit

Question 3

- (a) Scale 10C
Low partial credit: Any work of merit

High partial credit:
Diagram mainly correct but with some error(s)
- (b) Scale 5C
Low partial credit:
Any work of merit

High partial credit:
Median or Mode correct
- (c) Scale 10C
Low partial credit:
Any work of merit

High partial credit:
Calculates number of meals in Week1

Question 4

- (a) Scale 10C
Low partial credit:
Identifies the correct formula

High Partial credit:
Substitutes correctly into formula
- (b) Scale 10C
Low partial credit:
Identifies the correct formula

High Partial credit:
Substitutes correctly into formula
- (c) Scale 5C
Low partial credit:
Identifies the correct formula

High Partial credit:
Substitutes correctly into formula

Question 5

- (a) Scale 10D
Low partial credit:
Any work of merit
- Middle partial credit*
One point correct
- High partial credit:*
Two points correct
 x and y co-ordinates obviously interchanged
- (b) Scale 5C
Low partial credit:
Identifies the correct formula
- High Partial credit:*
Substitutes correctly into formula
- (c) (i) Scale 5C
Low partial credit:
Identifies the correct formula
- High Partial credit:*
Substitutes correctly into formula
- (ii) Scale 5C
Low partial credit:
Identifies the correct formula
- High Partial credit:*
Substitutes correctly into formula

Question 6

- (a) Scale 10B
Partial credit:
Incorrect activity chosen
- (b) Scale 5C
Low partial credit:
Any work of merit

High Partial credit:
Calculates size of angle for total of other activities
- (c) Scale 5C
Low partial credit:
Any work of merit

High partial credit:
Converts size of angle to equivalent fraction
- (d) Scale 5C
Low partial credit:
Any work of merit

High partial credit:
Calculates % time at his homework

Question 7

- (a) Scale 5C
Low partial credit:
Any work of merit
- High partial credit:*
Correct use of scale factor
- (b) Scale 5C
Low partial credit:
Any work of merit
- High partial credit:*
Correct use of scale factor
- (c) Scale 5C
Low partial credit:
Any work of merit e.g. formula written
- High partial credit:*
Substitutes correctly into formula
- (d) Scale 5C
Low partial credit:
Any work of merit
- High partial credit:*
Correct use of scale factor
- (e) Scale 5C
Low partial credit:
Any work of merit
- High partial credit:*
Correct numerator or correct denominator

Question 8A

- (a) Scale 10B
Partial credit:
Any work of merit
- (b) Scale 5B
Partial credit:
Any work of merit
- (c) Scale 10C
Low partial credit:
Any work of merit
- High partial credit:*
Draws correct tangent

Question 8B

- (a) Scale 5C
Low partial credit:
Any work of merit
- High partial credit:*
Pythagoras substituted correctly
- (b) Scale 5B
Partial credit:
Any work of merit
- (c) (i) Scale 10C
Low partial credit:
Identifies a triangle from diagram
- High Partial credit:*
One triangle correct
- (ii) Scale 5C
Low partial credit:
Some relevant with work $\angle AOC$
- High partial credit:*
One angle correct

Section B

Question 9

- (a) (i) Scale 10B
Partial credit:
Any work of merit
- (ii) Scale 5C
High Partial credit:
Highest and lowest temperature identified
- Low partial credit:*
One amount identified
- (iii) Scale 10D
Low partial credit:
Any work of merit
- Middle partial credit:*
Numerator or denominator correct
- High partial credit:*
Numerator and denominator correct
- (b) (i) Scale 5B
Partial credit:
Any work of merit
- (ii) Scale 10D
Low partial credit:
One correct entry
- Middle partial credit*
At least two correct entries
- High partial credit:*
At least five correct entries
- (iii) Scale 5C
Low partial credit:
Any work of merit
- High Partial credit:*
Calculates correct $f(x)$
- (iv) Scale 5C
Low partial credit:
Any work of merit
- High partial credit:*
Diagram mainly correct but with some error(s)

Question 10

- (a) (i) Scale 10C
Low partial credit:
Any work of merit
- High partial credit:*
Pythagoras substituted correctly
- (ii) Scale 5C
Low partial credit:
Any work of merit
- High partial credit:*
Fraction formulated correctly
- (iii) Scale 5C
Low partial credit:
Any work of merit
- High partial credit:*
Fraction formulated correctly
- (iv) Scale 5C
Low partial credit:
Any work of merit e.g. formula written
- High partial credit:*
Substitutes correctly into formula
- (v) Scale 10C
Low partial credit:
Any work of merit
- High partial credit:*
Substitutes correctly into formula
- (b) (i) Scale 10C
Low partial credit:
Any work of merit
- High partial credit:*
Substitutes correctly into formula
- (ii) Scale 5C
Low partial credit:
Any work of merit
- High partial credit:*
 $|\angle CAB| = \tan^{-1}\left(\frac{2 \cdot 5}{3}\right)$ or similar

Marcanna breise as ucht freagairt trí Ghaeilge

(Bonus marks for answering through Irish)

Ba chóir marcanna de réir an ghnáthráta a bhronnadh ar iarrthóirí nach ngnóthaíonn níos mó ná 75% d'iomlán na marcanna don pháipéar. Ba chóir freisin an marc bónais sin a shlánú **síos**.

Déantar an cinneadh agus an ríomhaireacht faoin marc bónais i gcás gach páipéir ar leithligh.

Is é 5% an gnáthráta agus is é 300 iomlán na marcanna don pháipéar. Mar sin, bain úsáid as an ngnáthráta 5% i gcás iarrthóirí a ghnóthaíonn 225 marc nó níos lú, e.g. $198 \text{ marc} \times 5\% = 9.9 \Rightarrow$ bónas = 9 marc.

Má ghnóthaíonn an t-iarrthóir níos mó ná 225 marc, ríomhtar an bónas de réir na foirmle $[300 - \text{bunmharc}] \times 15\%$, agus an marc bónais sin a shlánú **síos**. In ionad an ríomhaireacht sin a dhéanamh, is féidir úsáid a bhaint as an tábla thíos.

Bunmharc	Marc Bónais
226	11
227 – 233	10
234 – 240	9
241 – 246	8
247 – 253	7
254 – 260	6
261 – 266	5
267 – 273	4
274 – 280	3
281 – 286	2
287 – 293	1
294 – 300	0

Blank Page

