



**Coimisiún na Scrúduithe Stáit**  
**State Examinations Commission**

**Leaving Certificate 2015**

**Marking Scheme**

**Design and Communication Graphics**

**Ordinary Level**

### **Note to teachers and students on the use of published marking schemes**

Marking schemes published by the State Examinations Commission are not intended to be standalone documents. They are an essential resource for examiners who receive training in the correct interpretation and application of the scheme. This training involves, among other things, marking samples of student work and discussing the marks awarded, so as to clarify the correct application of the scheme. The work of examiners is subsequently monitored by Advising Examiners to ensure consistent and accurate application of the marking scheme. This process is overseen by the Chief Examiner, usually assisted by a Chief Advising Examiner. The Chief Examiner is the final authority regarding whether or not the marking scheme has been correctly applied to any piece of candidate work.

Marking schemes are working documents. While a draft marking scheme is prepared in advance of the examination, the scheme is not finalised until examiners have applied it to candidates' work and the feedback from all examiners has been collated and considered in light of the full range of responses of candidates, the overall level of difficulty of the examination and the need to maintain consistency in standards from year to year. This published document contains the finalised scheme, as it was applied to all candidates' work.

In the case of marking schemes that include model solutions or answers, it should be noted that these are not intended to be exhaustive. Variations and alternatives may also be acceptable. Examiners must consider all answers on their merits, and will have consulted with their Advising Examiners when in doubt.

### **Future Marking Schemes**

Assumptions about future marking schemes on the basis of past schemes should be avoided. While the underlying assessment principles remain the same, the details of the marking of a particular type of question may change in the context of the contribution of that question to the overall examination in a given year. The Chief Examiner in any given year has the responsibility to determine how best to ensure the fair and accurate assessment of candidates' work and to ensure consistency in the standard of the assessment from year to year. Accordingly, aspects of the structure, detail and application of the marking scheme for a particular examination are subject to change from one year to the next without notice.



**Coimisiún na Scrúduithe Stáit**  
*State Examinations Commission*

*Leaving Certificate Examination 2015*

***Design and Communication  
Graphics  
Ordinary Level***



***Marking Scheme  
and Sample Solutions***

**(Other valid solutions are acceptable and are marked accordingly)**

**QUESTION A-1**

**MARKS**

**(a) Elevation of Calculator (13)**

- (i) Projections from plan ..... 5
- (ii) Points correctly defined on the elevation ..... 4
- (iii) Complete elevation of calculator ..... 4

**(b) End elevation of Calculator (5)**

- (iv) Projections from plan ..... 1
- (v) Identify correct points ..... 2
- (vi) Complete the end elevation ..... 2
- (vii) *Presentation* ..... 2

*Total = 20*

**QUESTION A-2**

**MARKS**

**(a) Location of points (13)**

- (i) Complete division of CB ..... 2
- (ii) Division of CV ..... 2
- (iii) Construction lines (2 sets) ....(2,2) ..... 4
- (iv) Identify points on LHS of curve ..... 2
- (v) Points on RHS of curve ..... 3

**(b) Parabolic Curve (5)**

- (vi) Complete the curve on the LHS ..... 3
- (vii) Complete the curve on the RHS ..... 2
- (viii) *Presentation* ..... 2

*Total = 20*

**QUESTION A-3**

**MARKS**

**Perspective of TV (11)**

- (i) Radiate lines to correct vanishing point .....4
- (ii) Projection from plan .....4
- (iii) Complete LHS .....3

**Perspective of Stand (7)**

- (iv) Radiate lines to correct vanishing points .....2
- (v) Complete mid-section .....2
- (vi) Complete bottom section .....3
- (vii) *Presentation* .....2

**Total = 20**

**QUESTION A-4**

**MARKS**

**(a) Circle C (7)**

- (i) Arcs to locate centre .....2
- (ii) Draw circle C.....5

**(b) Circle D (7)**

- (iii) Constructions to locate centre .....2
- (iv) Draw circle D .....5

**(C) Points of Contact (4)**

- (v) Constructions to locate points of contact .....2
- (vi) Show points of contact .....2

- (vii) *Presentation* .....2

**Total = 20**

**QUESTION B-1**

**(a) Plan and Elevation (33)**

- (i) Draw plan of the tower as given .....5
- (ii) Draw the plan of main building as given .....4
- (iii) Draw the elevation of the tower as given .....5
- (iv) Draw the elevation of the main building as given .....4

***Interpenetration on Left Hand Side (LHS)***

- (v) Projections from LHS of plan .....2
- (vi) Locate points on LHS in elevation .....4
- (vii) Complete LHS of elevation .....3

***Interpenetration on Right Hand Side (RHS)***

- (viii) Projections from RHS of elevation .....2
- (ix) Locate points on RHS in plan .....2
- (x) Complete RHS of plan .....2

**(b) End View (8)**

- (xi) Transfer of widths from plan.....2
- (xii) Projection of heights from elevation .....2
- (xiii) End view of tower .....2
- (xiv) Complete end view .....2

- (xv) ***Presentation*** .....4
- 

***Total = 45***

**QUESTION B-2****MARKS**

<b>(a) Initial setup (5)</b>	
(i) Draw the equilateral triangle .....	3
(ii) Draw the X, Y and Z axes .....	2
<b>(b) Elevation and Plan (10)</b>	
(iii) Projections to set up elevation.....	2
(iv) Semicircle in elevation.....	1
(v) Draw the elevation in the correct position .....	2
(vi) Projections to set up plan .....	2
(vii) Semicircle in plan.....	1
(viii) Draw the plan in the correct position.....	2
<b>(c) Axonometric Projection of sides and roof (10)</b>	
(ix) Projections from the elevation .....	2
(x) Projections from the plan .....	2
(xi) Draw the axonometric projection of the walls.....	4
(xii) Draw the axonometric projection of the roof.....	2
<b>(d) Axonometric Projection of the Front of the kennel(16)</b>	
(xiii) Constructions for opening in elevation .....	3
(xiv) Constructions for opening in plan .....	3
(xv) Projections from the elevation of opening .....	3
(xvi) Projections from the plan of opening.....	3
(xvii) Draw axonometric projection of the circular section.....	2
(xviii) Complete the axonometric projection of the opening.....	2
(xix) <i>Presentation</i> .....	4

---

**Total = 45**

**QUESTION B-3**

**(a) Elevation (18)**

- (i) Elevation of counter ..... 8
- (ii) Outline elevation of sandwich display unit ..... 4
- (iii) Construction to establish height of front surface of display unit ..... 2
- (iv) Complete the sandwich display unit ..... 4

**(b) Plan (11)**

- (v) Outline of counter..... 7
- (vi) Draw plan of sandwich unit ..... 4

**(c) Auxiliary elevation (12)**

- (vii)  $X_1Y_1$  parallel to plan of surface A ..... 2
- (viii) Projections from plan ..... 1
- (ix) Transfer heights from elevation ..... 2
- (x) Draw surface A ..... 3
- (xi) Complete auxiliary elevation ..... 4
  
- (xii) **Presentation** ..... 4

---

**Total = 45**



**QUESTION C-1**

**MARKS**

<b>(a) Profile (22)</b>	
(i) Measure heights and draw horizontal lines .....	6
(ii) Projections from intersections between line AB and contours .....	8
(iii) Draw the profile .....	8
<b>(b) Strike and dip (16)</b>	
(iv) Join points in plan.....	5
(v) Draw triangle in elevation .....	3
(vi) Horizontal line in elevation .....	2
(vii) Strike in plan .....	2
(viii) Viewing direction for dip .....	2
(ix) Determine dip (2 heights, edge view) .....	2
<b>(c) Bottom Surface of Stratum (3)</b>	
(x) Measure correct thickness for stratum .....	1
(xi) Draw the bottom surface of the stratum .....	2
(xii) <i>Presentation</i> .....	4

***Total = 45***

**QUESTION C-2**

**MARKS**

**(a) Elevation and Plan (25)**

- (i) Outline of surface ABCD in elevation .....6
- (ii) Elements in elevation (incl. division) .....7
- (iii) Outline of surface in plan .....6
- (iv) Elements in plan (incl. division or proj.) .....4
- (v) Curve in plan .....2

**(b) End view of Hyperbolic Paraboloid (16)**

- (vi) Determine heights and widths for surface ABCD .....6
- (vii) Draw the outline of the hyperbolic paraboloid .....4
- (viii) Draw the elements .....4
- (ix) Curve in end view .....2
  
- (x) *Presentation* .....4

---

*Total = 45*

**QUESTION C-3****MARKS****(a) Plan and Elevation (16)**

- (i) Draw the straight edges of the elevation .....6
- (ii) Locate the centre of the arc in elevation .....1
- (iii) Complete the elevation .....3
- (iv) Draw the plan of the bag .....6

**(b) End View (6)**

- (v) Projections from the elevation .....2
- (vi) Width from plan .....1
- (vii) Complete the end elevation .....3

**(c) Surface development (19)**

- (viii) Appropriate layout of surface development .....2
- (ix) Development of bottom surface .....2
- (x) Development of vertical end surfaces .....4
- (xi) Development of inclined surfaces .....3
- (xii) Development of front and back surfaces .....3
- (xiii) Division of curved surface .....3
- (xiv) Development of curved surface .....2
- (xv) *Presentation* .....4

---

**Total = 45**

**QUESTION C-4****MARKS****(a) Displacement Diagram (27)**

(i)	360° division (widths on displacement diag.) .....	6
(ii)	Correct use of 60mm height .....	2
(iii)	Establish follower position at 0°, 120°, 180° and 360° .....	4
(iv)	0° to 120°, Uniform Velocity .....	3
(v)	120° to 180°, Dwell .....	3
(vi)	180° to 360°, Simple Harmonic Motion (SHM) .....	6
(vii)	Complete Displacement Diagram .....	3

**(b) Cam Profile (14)**

(viii)	Cam centre and nearest approach .....	2
(ix)	Camshaft .....	1
(x)	Angular divisions corresponding to displacement diagram .....	3
(xi)	Correct direction of rotation .....	1
(xii)	Identify points on the profile .....	3
(xiii)	Draw the cam profile .....	4
(xiv)	<b>Presentation</b> .....	4

---

**Total = 45**

**QUESTION C-5****MARKS*****Assembly (11)***

- (i) Relative positioning of components ..... 8
- (ii) Use of Section View ..... 3

***Bottom Handle (7)***

- (iii) Outline ..... 5
- (iv) Hole ..... 2

***Top Handle (7)***

- (v) Outline ..... 5
- (vi) Hole ..... 2

***Metal Jaws (6)***

- (vii) Bottom Jaw ..... 3
- (viii) Top Jaw ..... 3

***Pin Holders (4)***

- (ix) Bottom pin holder ..... 2
- (x) Top pin holder ..... 2

***Pins (3)***

- (xi) 50mm pins ..... 2
- (xii) 42mm pin ..... 1

***Drawing Completion (3)***

- (xiii) Hatching and Centrelines ... (2,1) ..... 3
- (xiv) ***Presentation*** ..... 4

---

**Total = 45**

## SECTION A - Core - Answer any three of the questions on this A3 sheet.

**A-1.** The 3D graphic below shows an image of a calculator. The plan and partially completed elevation and end view are also shown.

- (a) Complete the elevation of the calculator.  
 (b) Complete the end view of the calculator.

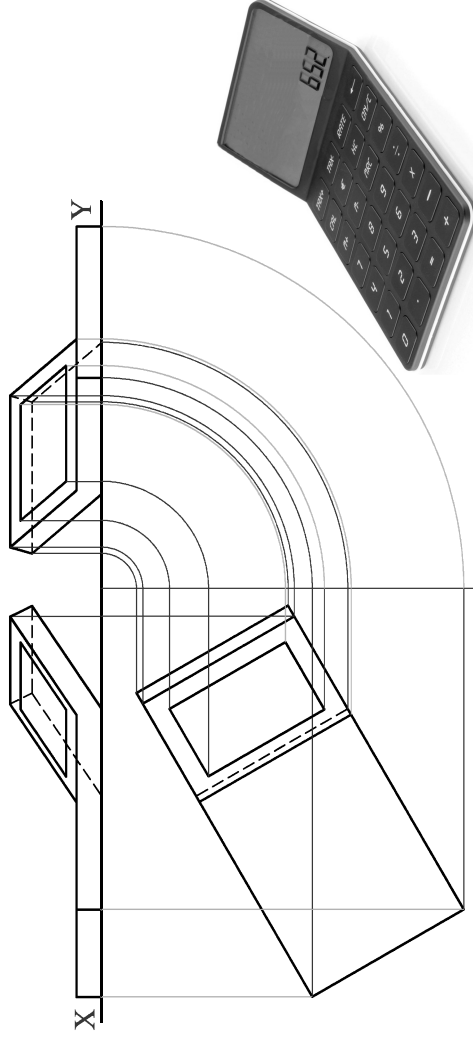

**A-3.** The 3D graphic below shows a widescreen plasma TV on a rectangular stand.  
 The drawing on the right shows the plan and a partially completed perspective drawing of the TV.  
 Complete the perspective drawing of the TV and stand.

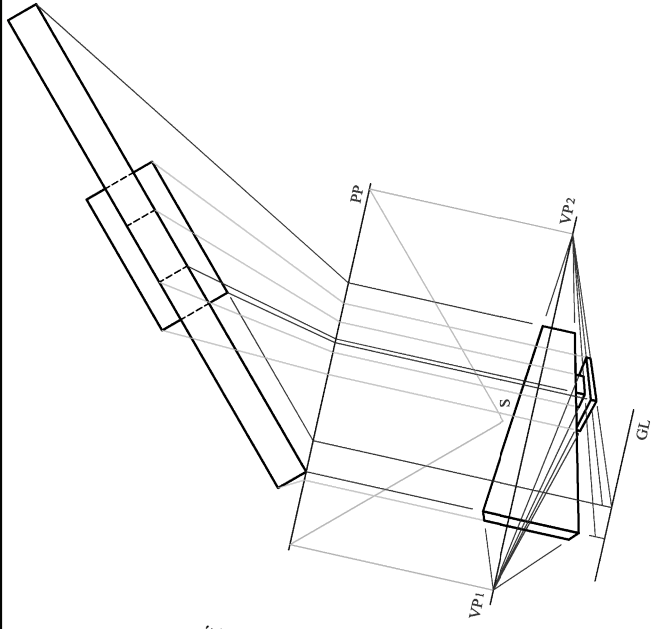

**A-2.** The graphic on the right shows an image from the 'Angry Birds' computer game. The curve is in the shape of a parabola. The drawing below shows a portion of a parabola inscribed in a rectangle ABCD. V is the vertex of the parabola.

- (a) Locate the remaining points on the parabola.  
 (b) Draw the complete parabola.

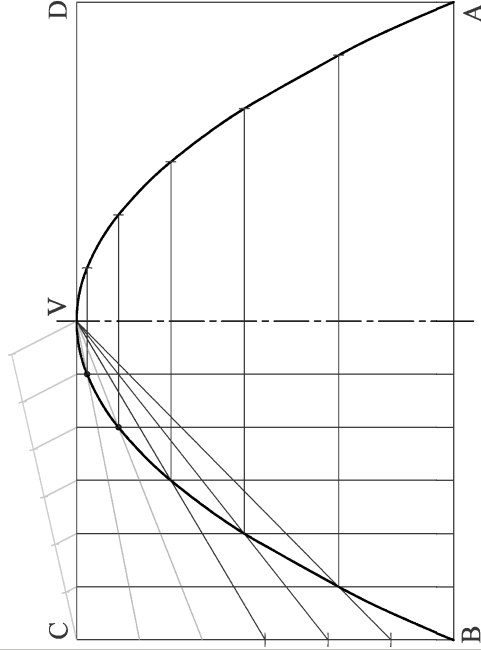

**A-4.** The drawing below shows an arrangement of circles similar to those in the toy on the right.

The horizontal line RS and circles A and B are in fixed positions as shown. Circles C and D are free to move.

- (a) Redraw circle C when it has been moved to position C<sub>1</sub> and is in contact with circles A and B.  
 (b) Redraw circle D when it has been moved to position D<sub>1</sub> and is in contact with circle B and the line RS.  
 (c) Show all points of contact.

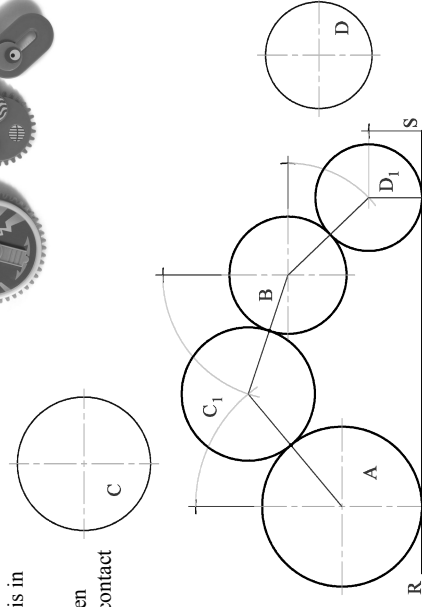

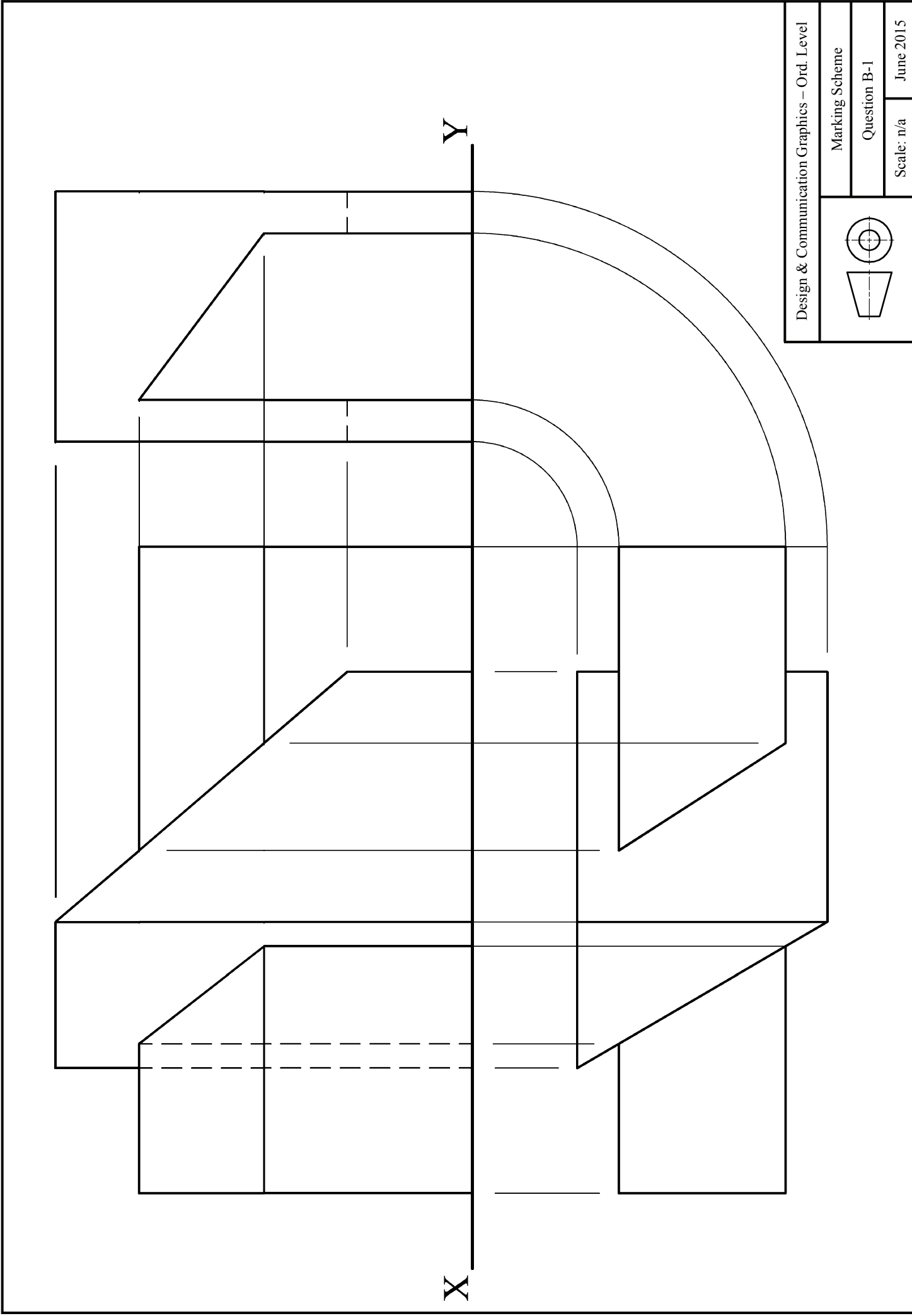

Design & Communication Graphics – Ord. Level

Marking Scheme

Question B-1

Scale: n/a June 2015

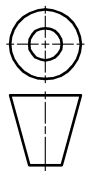

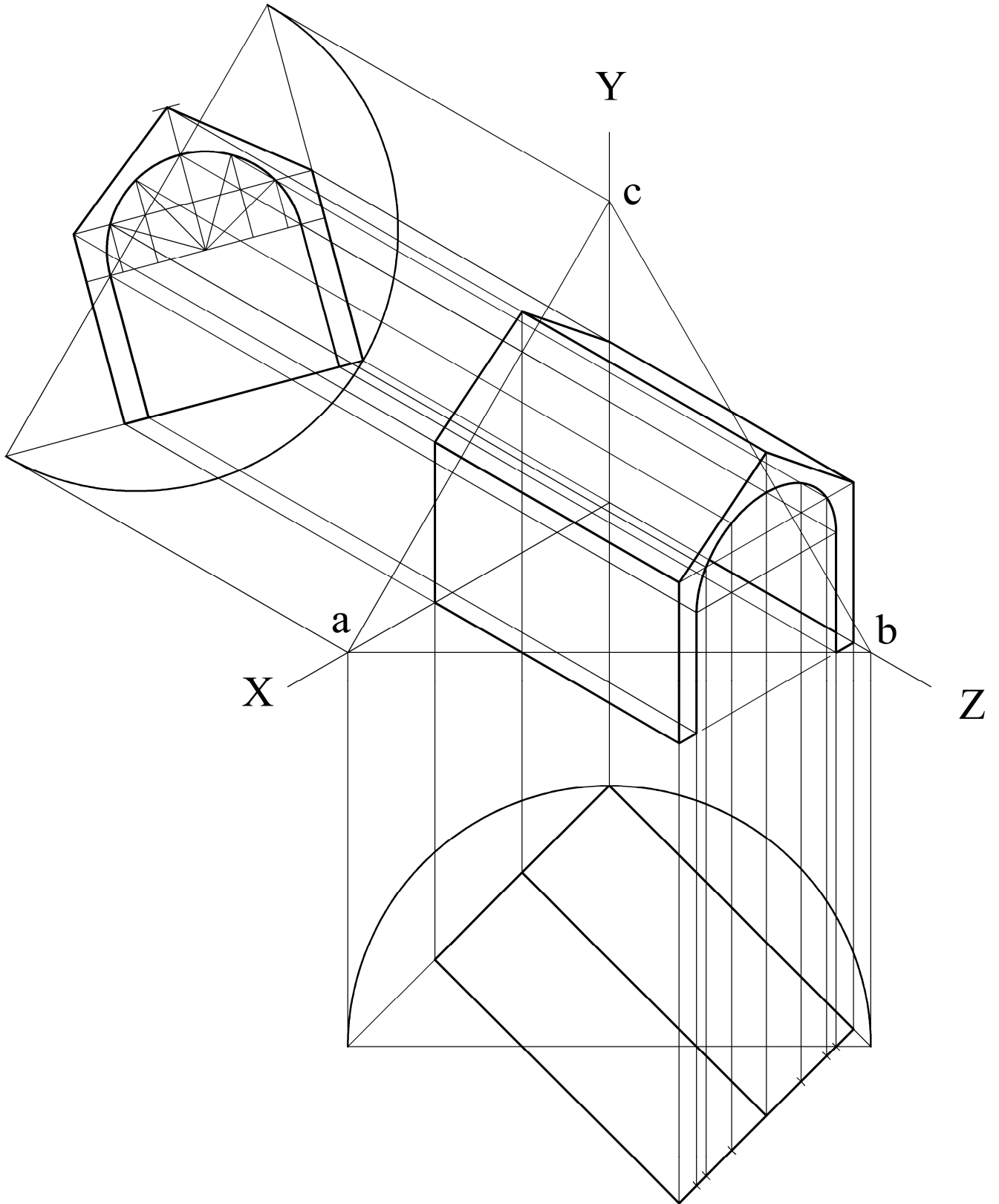
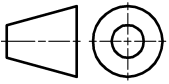



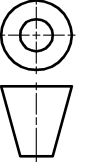
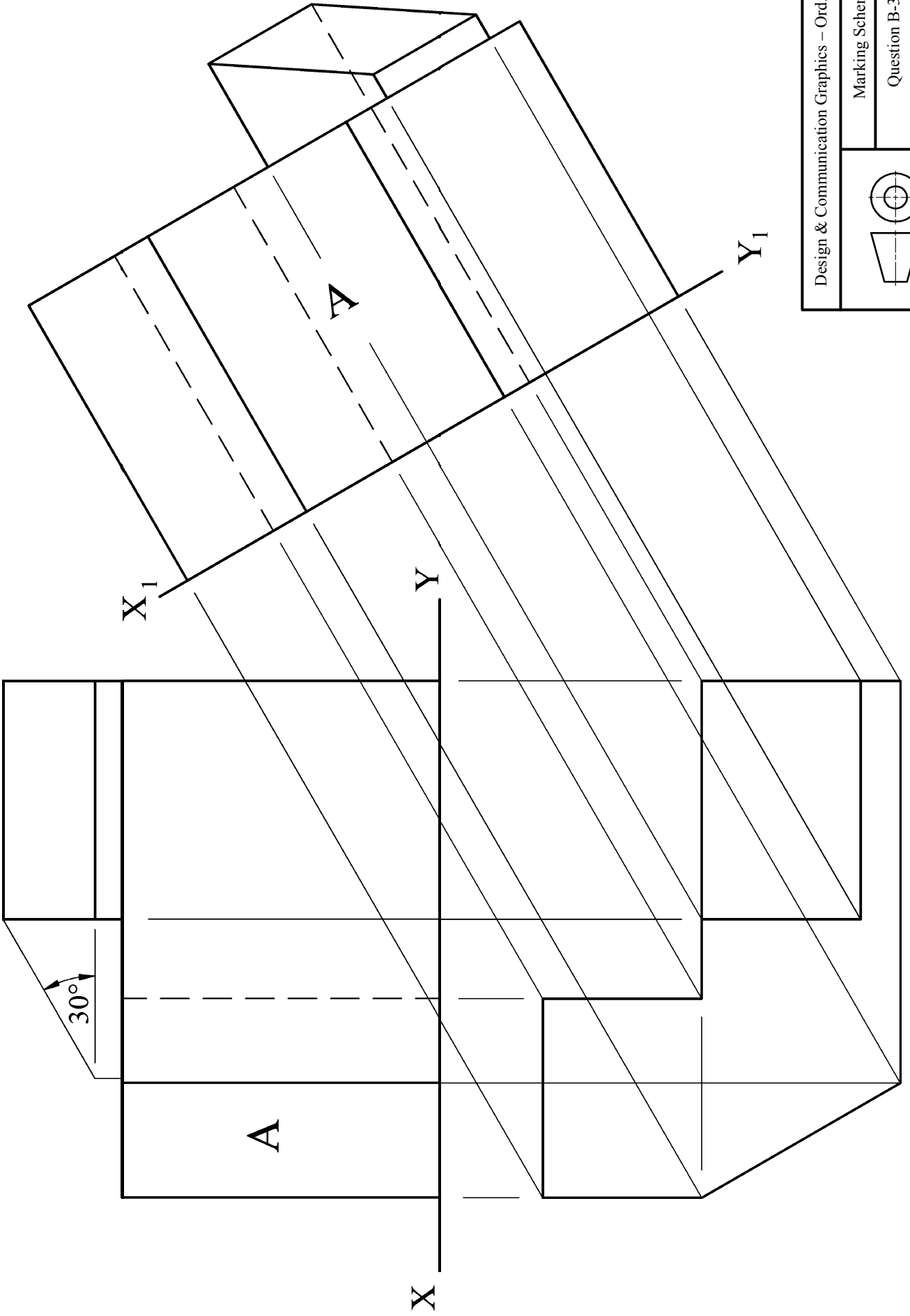

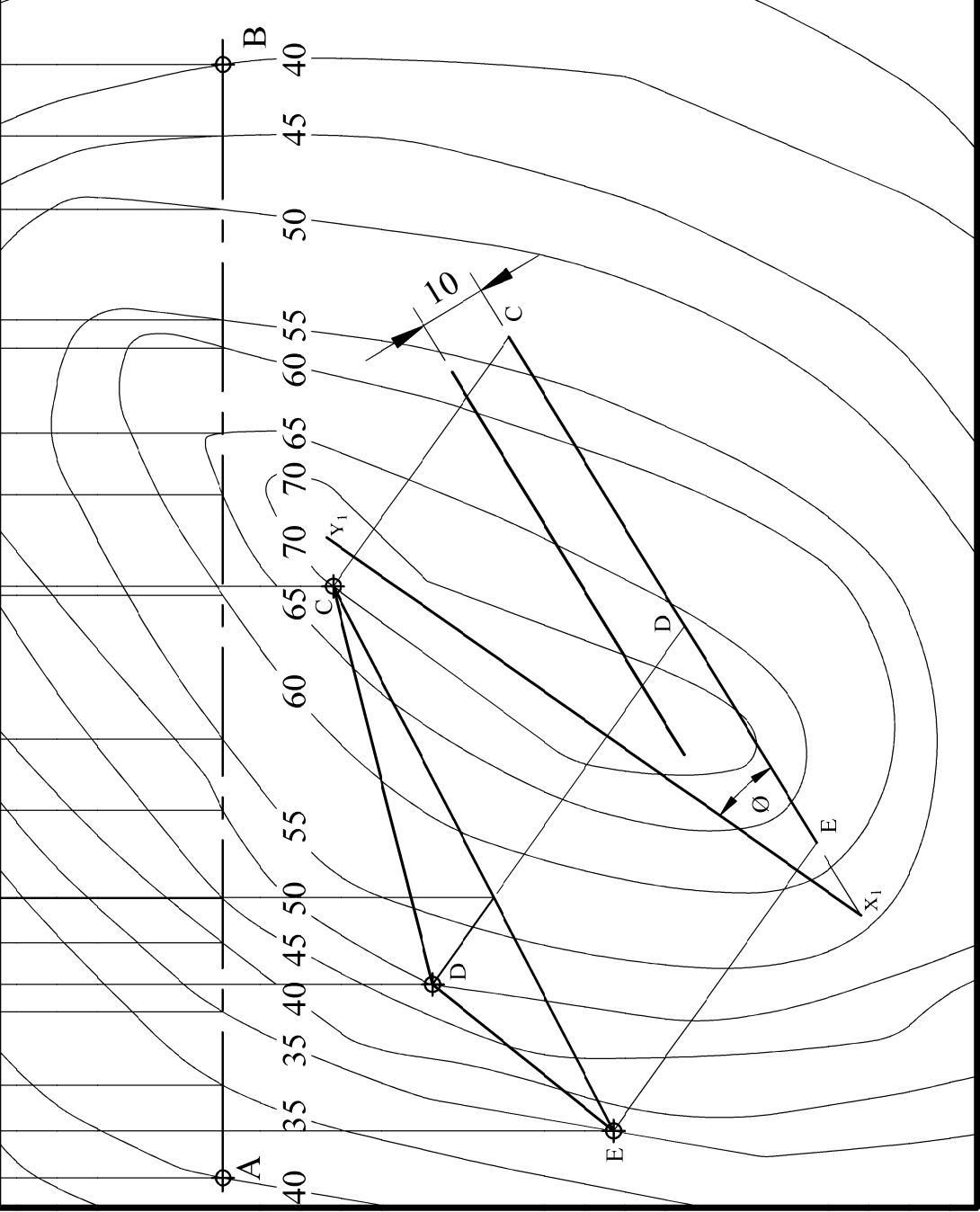
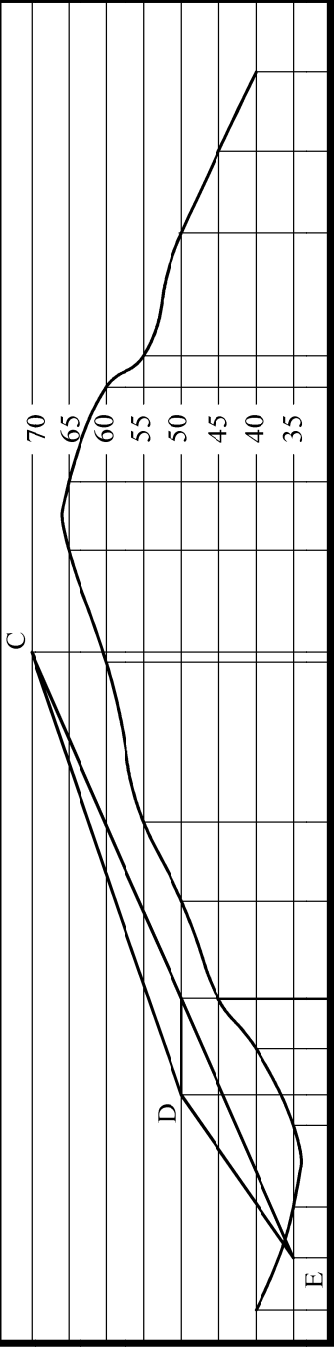
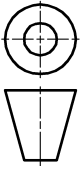

70  
65  
60  
55  
50  
45  
40  
35

40 45 50 55 60 65 70

40 45 50 55 60 65 70

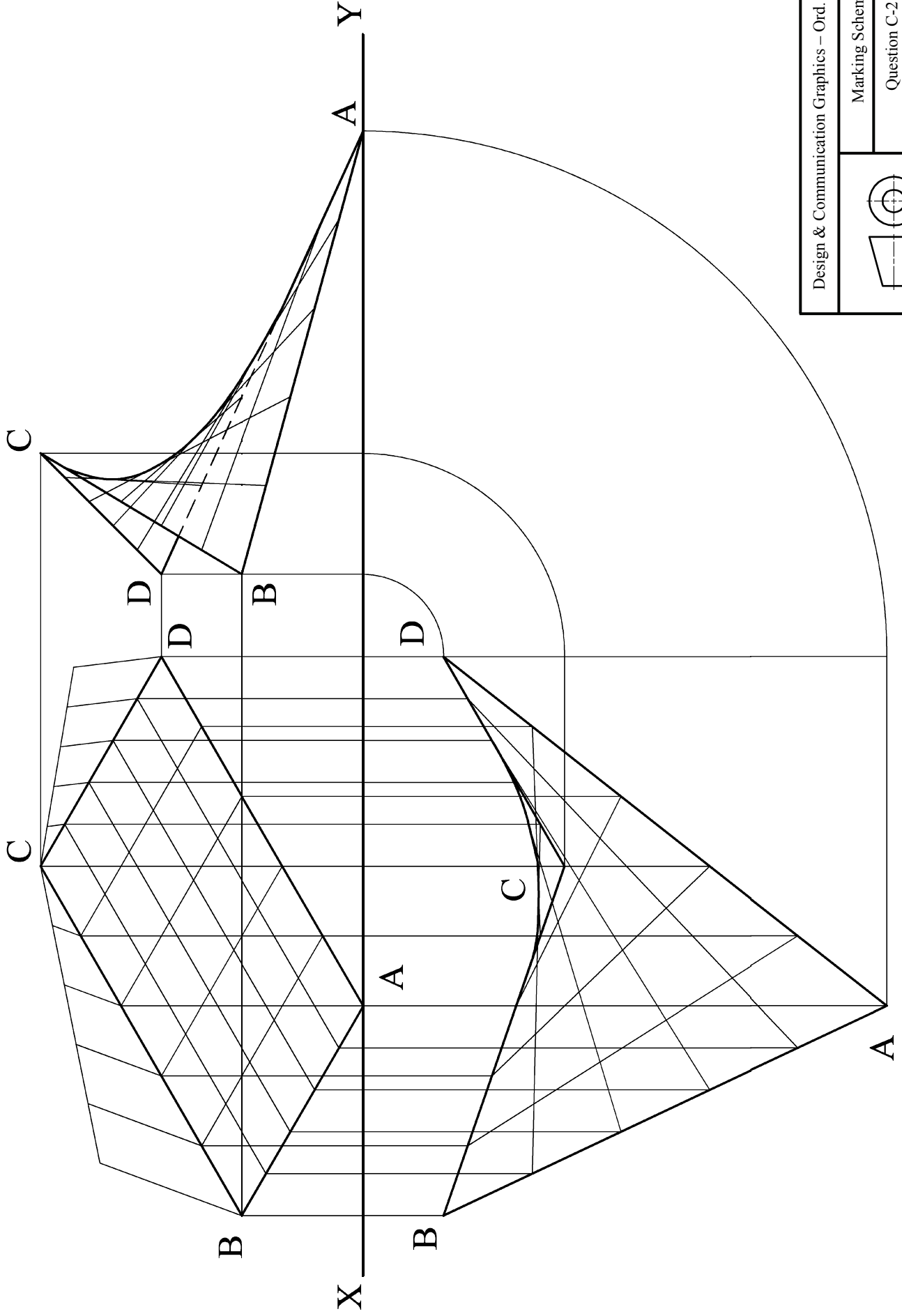

Design & Communication Graphics – Ord. Level

Marking Scheme

Question C-2

Scale: n/a June 2015

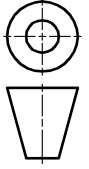

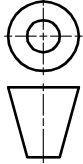

Marking Scheme

Question C-3

Scale: n/a

June 2015

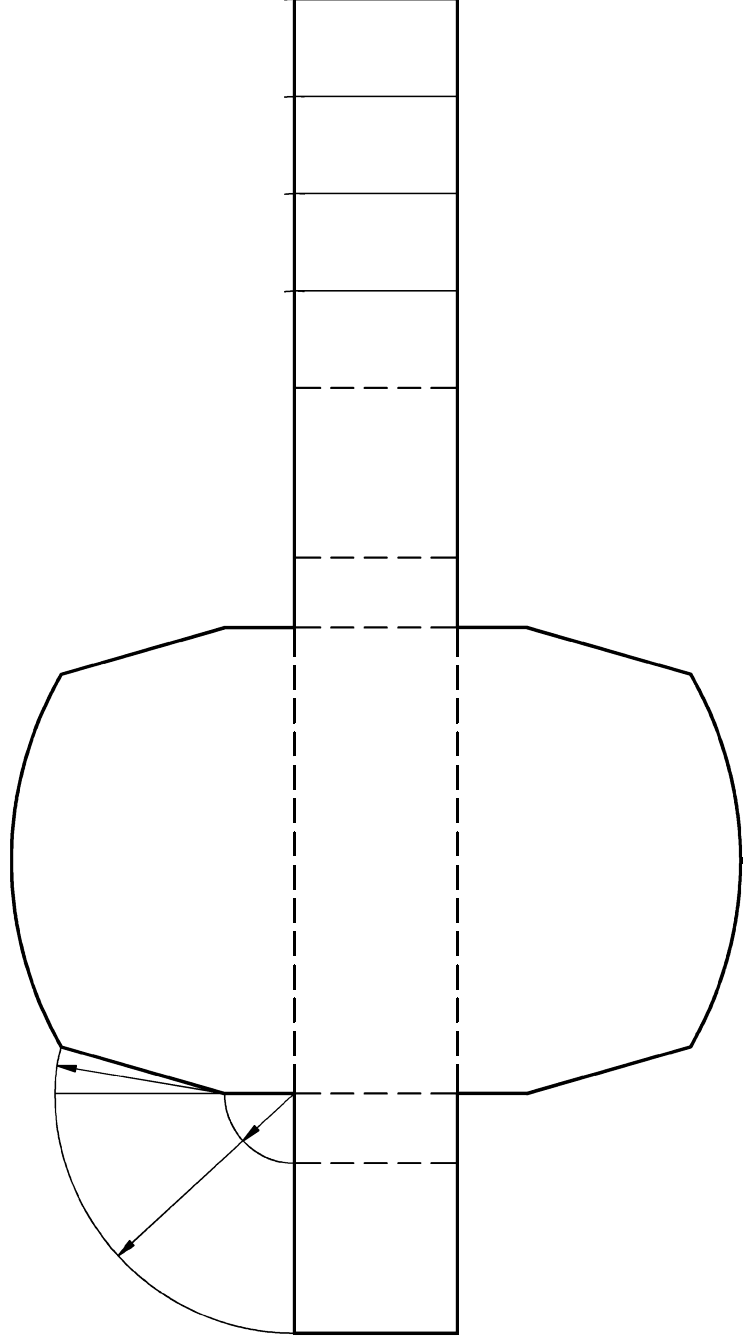
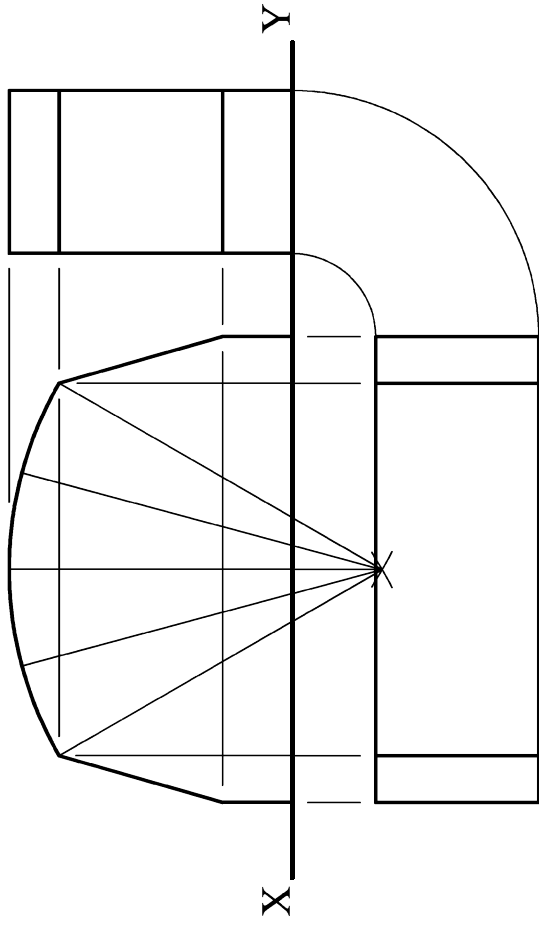

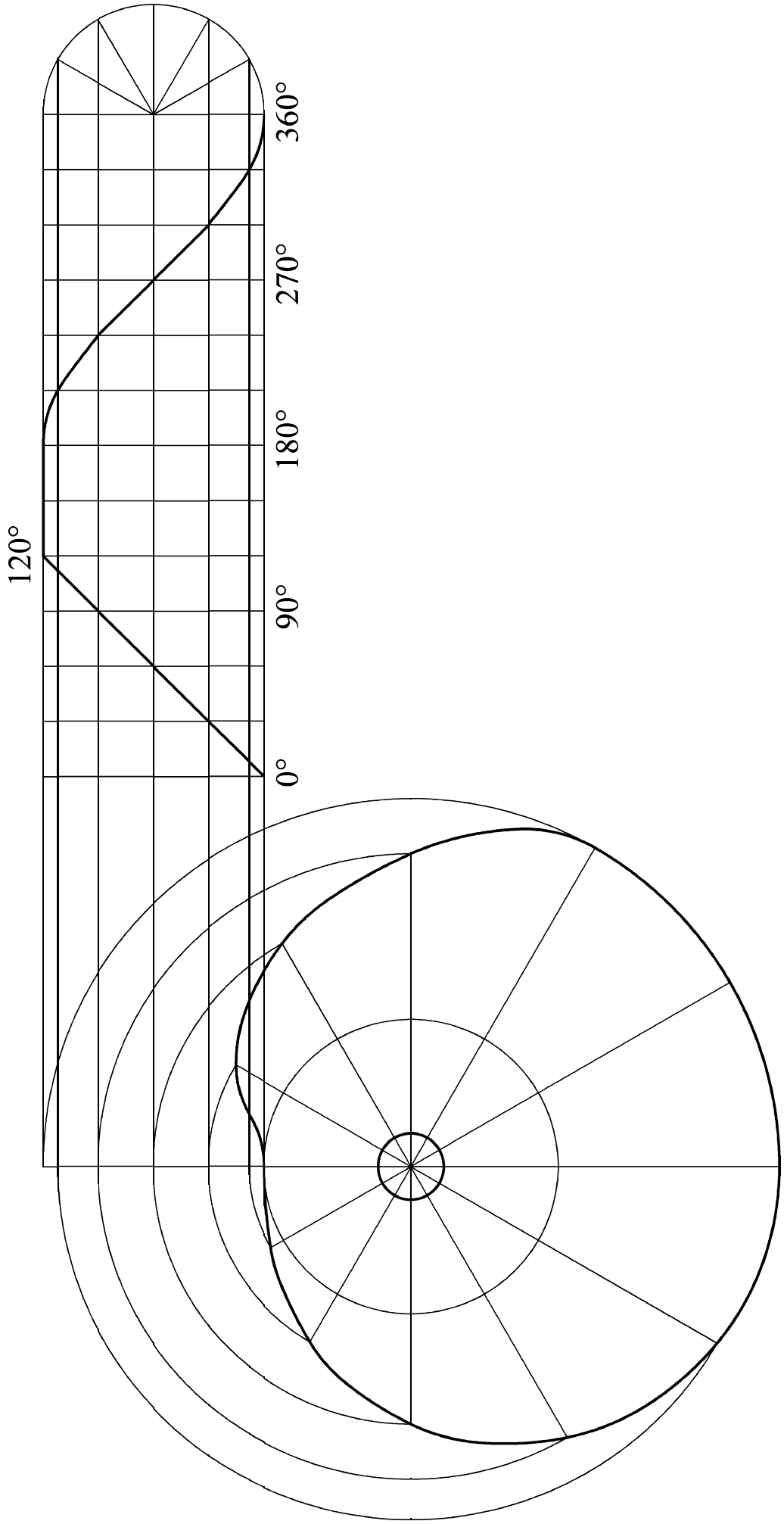

Design & Communication Graphics – Ord. Level

Marking Scheme

Question C-4

Scale: n/a June 2015

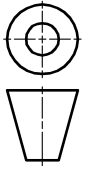

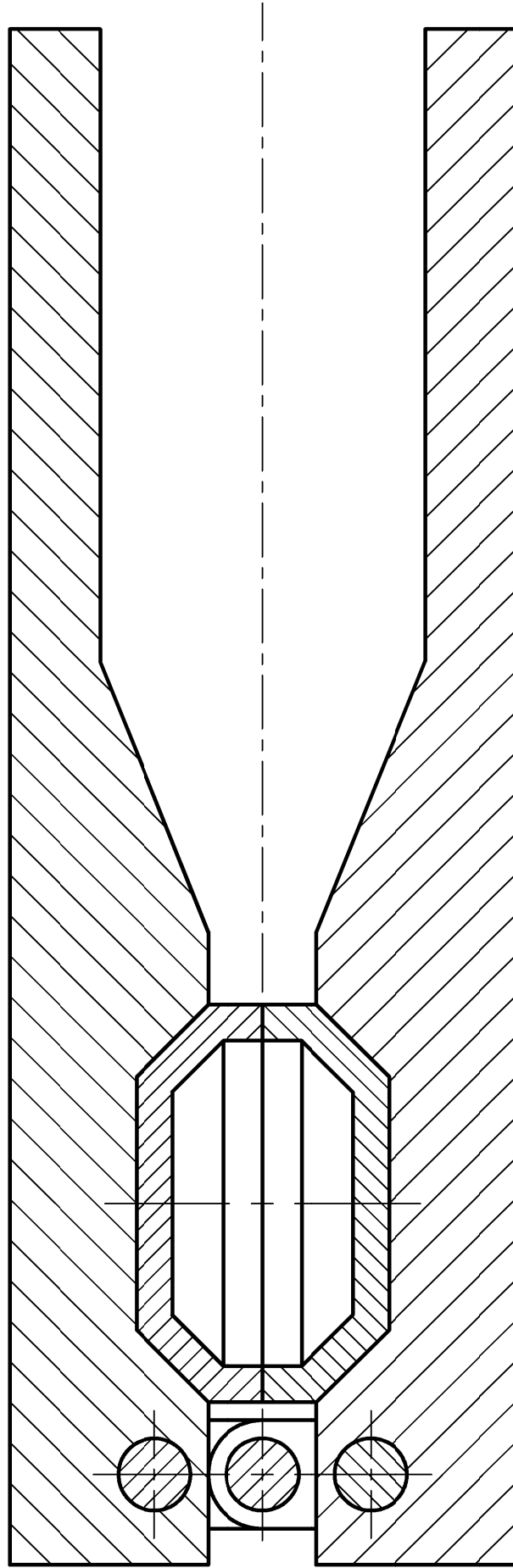

Design & Communication Graphics – Ord. Level

Marking Scheme

Question C-5

Scale: n/a

June 2015

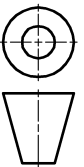



# Design and Communication Graphics

## Student Assignment - Ordinary Level

### Assessment Sheet 2015

Candidate Exam No.

Output	Marking criteria	Marks
<b>1</b>	<b>Design Research</b> - Exploration of main design features using primary & secondary research; Selection of appropriate graphics; Effective layout and presentation of information combining images, sketches & annotations	
	a) Extensive range of relevant criteria considered - excellent presentation	13 - 15
	b) Most relevant criteria considered - very good presentation	10 - 12
	c) Some relevant criteria considered - good presentation	7 - 9
	d) Limited criteria considered - fair presentation	4 - 6
	e) At least one criterion considered - poor presentation	0 - 3
<b>2</b>	<b>Design Feature Comparison</b> - Selection of two appropriate images; Main dimensions inserted; Comparison of main design features; Contrasting of main design features; Effective layout and presentation of information combining images, sketches & annotations	
	a) Extensive range of relevant criteria considered - excellent presentation	13 - 15
	b) Most relevant criteria considered - very good presentation	10 - 12
	c) Some relevant criteria considered - good presentation	7 - 9
	d) Limited criteria considered - fair presentation	4 - 6
	e) At least one criterion considered - poor presentation	0 - 3
<b>3</b>	<b>Freehand Graphical Representation</b> – Proportion; Form/Volume; Use of Tone/Line for effective rendering; Detailed communication of main design features to include 3D presentation quality drawing; Layout & presentation	
	a) Extensive range of relevant criteria considered - excellent presentation	17 - 20
	b) Most relevant criteria considered - very good presentation	13 - 16
	c) Some relevant criteria considered - good presentation	9 - 12
	d) Limited criteria considered - fair presentation	5 - 8
	e) At least one criterion considered - poor presentation	0 - 4
<b>4</b>	<b>SolidWorks Parts, Assembly, Drawing and eDrawing files</b>	
	• Adherence to required filing structure	4
	• Creation of a minimum of 3 Part files	6
	• Part models - Proficiency in Parametric CAD; Selection of most appropriate profile; Sketches fully defined; Features renamed; Appropriate type of extrusions used	12
	• Assembly – Creation of Assembly environment; Accuracy of parts to facilitate correct assembly; Correct mating of parts; Application of appropriate appearances	6
	• Factor of difficulty	3
	• eDrawing of CAD model	2
<b>5</b>	<b>Hardcopy outputs from SolidWorks</b> - Detailed orthographic views of the Assembly; Rendered pictorial view of the Assembly; Exploded view of the CAD model; Inclusion of main dimensions; Scaling, layout and presentation	
	a) Extensive range of relevant criteria considered - excellent presentation	17 - 20
	b) Most relevant criteria considered - very good presentation	13 - 16
	c) Some relevant criteria considered - good presentation	9 - 12
	d) Limited criteria considered - fair presentation	5 - 8
	e) At least one criterion considered - poor presentation	0 - 4
<b>6</b>	<b>Photorealistic Representation</b>	
	Produce photorealistic computer generated images of the artefact	7
<b>7</b>	<b>Graphical exploration of design solutions</b> - Exploration of theme/possible solution(s); Justification of chosen solution(s); Use of appropriate images/graphics; Effective layout and presentation of information combining images, sketches & annotations	
	a) Extensive range of relevant criteria considered - excellent presentation	17 - 20
	b) Most relevant criteria considered - very good presentation	13 - 16
	c) Some relevant criteria considered - good presentation	9 - 12
	d) Limited criteria considered - fair presentation	5 - 8
	e) At least one criterion considered - poor presentation	0 - 4
<b>8</b>	<b>Presentation of Modification/Concept Design</b> – Proportion, Form/Volume, Use of Tone/Line for effective rendering, Detailed communication of modified/concept design features; Layout and presentation	
	a) Extensive range of relevant criteria considered - excellent presentation	9 - 10
	b) Most relevant criteria considered - very good presentation	7 - 8
	c) Some relevant criteria considered - good presentation	5 - 6
	d) Limited criteria considered - fair presentation	3 - 4
	e) At least one criterion considered - poor presentation	0 - 2
<b>9</b>	<b>Hardcopy outputs from SolidWorks</b> - CAD model; Detailed orthographic views of the proposed solution; Rendered pictorial view of the CAD model, Inclusion of main dimensions; Scaling, layout and presentation	
	• Application of CAD skills	5
	a) Extensive range of relevant criteria considered - excellent presentation	13 - 15
	b) Most relevant criteria considered - very good presentation	10 - 12
	c) Some relevant criteria considered - good presentation	7 - 9
	d) Limited criteria considered - fair presentation	4 - 6
	e) At least one criterion considered - poor presentation	0 - 3
<b>Sub-total</b>		
	<b>Marks deducted for pages in excess of maximum</b>	
		<b>Total</b>

