



Coimisiún na Scrúduithe Stáit
State Examinations Commission

Leaving Certificate 2012

Marking Scheme

Design and Communication Graphics

Ordinary Level



Coimisiún na Scrúduithe Stáit
State Examinations Commission

Leaving Certificate Examination 2012

***Design and Communication
Graphics
Ordinary Level***



***Marking Scheme
and Sample Solutions***

(Other valid solutions are acceptable and are marked accordingly)

QUESTION A-1**MARKS**

- (a) **Minor Axis (8)**
- (i) Locate midpoint of AB2
- (ii) Draw minor axis line2
- (iii) Locate end point(s) of minor axis4
- (b) **Semi-Ellipse (10)**
- (iv) Appropriate method of construction2
- (v) Locate points on curve4
- (vi) Draw curve4
- (vii) **Presentation**2

Total = 20**QUESTION A-2****MARKS**

- (a) **Sphere B (8)**
- (i) Projection of centre from plan2
- (ii) Establish the centre point in elevation3
- (iii) Draw sphere B3
- (b) **Sphere C (10)**
- (iv) Constructions in elevation2
- (v) Projections to plan2
- (vi) Locate centre point in plan2
- (vii) Draw sphere C in plan(incl. hidden detail).....2
- (viii) Draw sphere C in elevation(incl. hidden detail).....2
- (ix) **Presentation**2

Total = 20

QUESTION A-3

MARKS

Axonometric Projection (18)

- | | |
|---|---|
| (i) Perp. projections from plan(4x1,1)..... | 5 |
| (ii) Perp. projections from elevation(3x1,2)..... | 5 |
| (iii) Identify points on the axonometric projection | 3 |
| (iv) Complete the axonometric projection | 5 |
| (v) <i>Presentation</i> | 2 |

Total = 20

QUESTION A-4

MARKS

- | | |
|---|---|
| (i) Prism widths transferred to label in plan | 2 |
| (ii) Label end transferred to prism in plan | 2 |
| (iii) Projections to elevation | 4 |
| (iv) Identify points on envelopment | 4 |
| (v) Drawing of envelopment | 5 |
| (vi) Hidden detail | 1 |
| (vii) <i>Presentation</i> | 2 |

Total = 20

QUESTION B-1

MARKS

(a) Plan and Elevation (33)

- (i) Draw the plan of centre section as given 3
- (ii) Complete the plan as given 4
- (iii) Draw the elevation of the centre section as given 3
- (iv) Complete the elevation as given..... 4

Interpenetration on Left Hand Side (LHS)

- (v) Projection from LHS of elevation 2
- (vi) Locate points on LHS in plan 4
- (vii) Complete LHS of plan 3

Interpenetration on Right Hand Side (RHS)

- (viii) Projections from RHS of plan 2
- (ix) Locate points on RHS in elevation 4
- (x) Complete RHS of elevation 4

(b) End View (8)

- (xi) Transfer of widths from plan..... 2
- (xii) Projection of heights from elevation 2
- (xiii) End view of centre prism 2
- (xiv) Complete end view 2
- (xv) ***Presentation*** 4

Total = 45

QUESTION B-2**MARKS**

(a) Plan (10)	
(i) Plan of structure	8
(ii) Correct orientation of plan	2
(b) Perspective drawing (31)	
(iii) Plan of spectator, PP, VP ₁ and VP ₂	4
(iv) Elevation of GL, HL, VP ₁ and VP ₂	8
(v) Sight lines from spectator to plan	5
(vi) Perspective of bottom edges	4
(vii) Establish height for the table	2
(viii) Perspective of table body	2
(ix) Establish heights for the V section (h ₁) and net (h ₂)	2
(x) Perspective of V section	2
(xi) Perspective of net	2
(xii) Presentation	4
	—
	Total = 45

QUESTION B-3

(a) Elevation (14)

- (i) Rectangular outline of elevation 8
- (ii) Complete the elevation 6

(b) Plan (12)

- (iii) Rectangular outline in plan 8
- (iv) Complete the plan..... 4

(c) Auxiliary elevation (15)

- (v) X_1Y_1 parallel to plan of surface A 1
- (vi) Projections from plan 1
- (vii) Transfer heights from elevation 2
- (viii) Draw surface A 2
- (ix) Complete auxiliary elevation 9

- (x) **Presentation** 4
-

Total = 45

QUESTION C-1

MARKS

- (a) Profile (19)**
- (i) Measure heights and draw horizontal lines6
 - (ii) Projections from intersections between line AB and contours5
 - (iii) Draw outline of profile8
- (b) Water depth (6)**
- (iv) Identify the maximum water depth2
 - (v) Draw horizontal line on profile4
- (c) Earthworks for roadway (16)**
- (vi) Parallel lines at 5m intervals6
 - (vii) Identify points on earthworks curve5
 - (viii) Draw earthworks curve5
 - (ix) *Presentation*4

Total = 45

QUESTION C-2

MARKS

(a) Elevation and Plan (23)

(i) Outline of surface ABCD in elevation	5
(ii) Elements in elevation (incl. division)	7
(iii) Outline of surface ABCD in plan	4
(iv) Elements in plan (incl. division or proj.)	5
(v) Curve in elevation	2

(b) End view of Hyperbolic Paraboloid (18)

(vi) Determine heights and widths for surface ABCD	4
(vii) Draw the outline of the hyperbolic paraboloid	6
(viii) Draw the elements	6
(ix) Curve in end view	2
(x) <i>Presentation</i>	4

Total = 45

QUESTION C-3

MARKS

(a) Plan and Elevation (19)

- (i) Draw straight line edges in elevation6
- (ii) Establish centre and draw curve(4,3).....7
- (iii) Draw plan6

(b) Surface development (22)

- (iv) Development of base4
- (v) Development of rectangular sides6
- (vi) Development of front and back surfaces6
- (vii) Division of curved surface3
- (viii) Development of curved surface3

- (ix) *Presentation*4

Total = 45

QUESTION C-4**MARKS****(a) Displacement Diagram (22)**

(i)	360° division (widths on displacement diag.)	6
(ii)	Establish follower position at 0°, 90°, 180° and 360°	4
(iii)	0° to 90°, Uniform Velocity	3
(iv)	90° to 180°, Dwell	3
(v)	180° to 360°, Simple Harmonic Motion	3
(vi)	Complete Displacement Diagram	3

(b) Displacement Diagram (19)

(vii)	Draw the given plan	4
(viii)	Draw the outline elevation	4
(ix)	Complete division of plan	2
(x)	Complete horizontal divisions in elevation	2
(xi)	Complete projections from plan of helix	2
(xii)	Locate points in elevation	2
(xiii)	Draw the helix in elevation	3
(xiv)	Presentation	4

Total = 45

QUESTION C-5**MARKS*****Assembly (10)***

(i) Relative positioning of components 10

Wall mount (8)

(ii) Outline 4

(iii) Hole 2

(iv) Completion 2

Stem (5)

(v) Correct shape and diameter 3

(vi) Threaded ends 2

Dish Support (5)

(vii) Outline 2

(viii) Hole 1

(ix) Completion 2

Soap Dish (5)

(x) Outline 3

(xi) Completion 2

Screw (4)

(xii) Head (incl. slot) 2

(xiii) Shaft (incl. threads) 2

Drawing Completion (4)

(xiv) Hatching and Centrelines ... (2,2) 4

(xv) ***Presentation*** 4

Total = 45

SECTION A - Core - Answer Any Three of the questions on this A3 sheet

A-1. The 3D graphic below shows a garage door. The top of the door is in the shape of a semi-ellipse.

In the drawing of the door on the right, **AB** is the major axis of the ellipse. The focal points are also shown.

- (a) Locate the minor axis of the ellipse.
- (b) Draw the semi-ellipse.

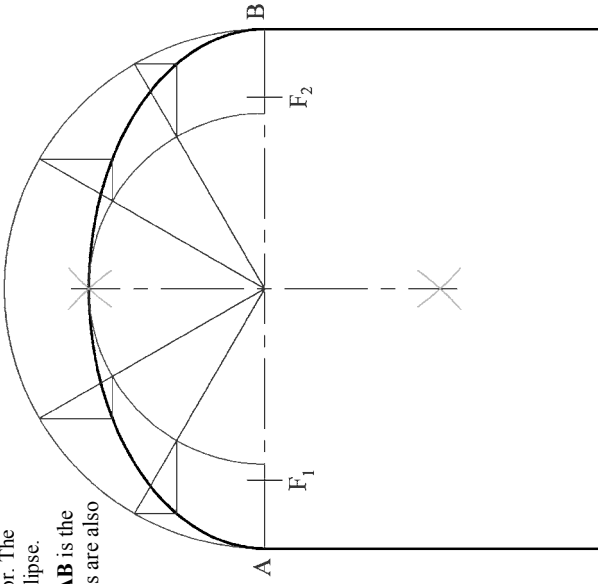

A-3. The 3D graphic below shows a traffic bollard.

A set of isometric axes and a partially completed outline drawing of the bollard are shown on the right. The elevation and plan of the bollard have been positioned relative to the axes as shown.

Complete the axonometric projection.

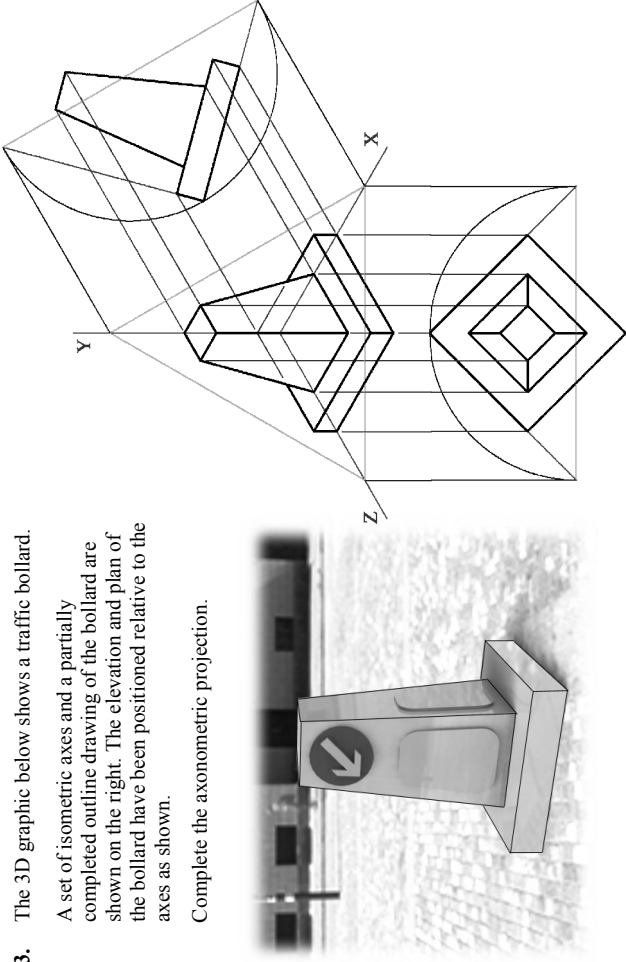

A-2. The 3D graphic below shows a garden water feature in which three spheres rest on the ground and are in mutual contact.

The drawing on the right shows the plan and elevation of sphere **A**. The plan of sphere **B** is also shown.

- (a) Draw the elevation of sphere **B**.
- (b) Draw the plan and elevation of the third Sphere, **C** (shown in blue) when it has been moved into position **C₁** and is in contact with the given spheres **A** and **B**.

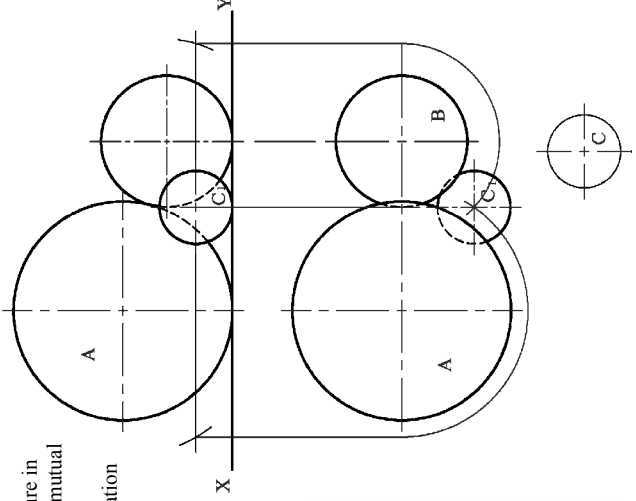

A-4. The 3D graphic below shows a jar of honey and a label which is to be wrapped around it.

The drawing on the right shows the plan and elevation of the label and the hexagonal portion of the glass jar.

Complete the elevation showing the label in the wrapped position.

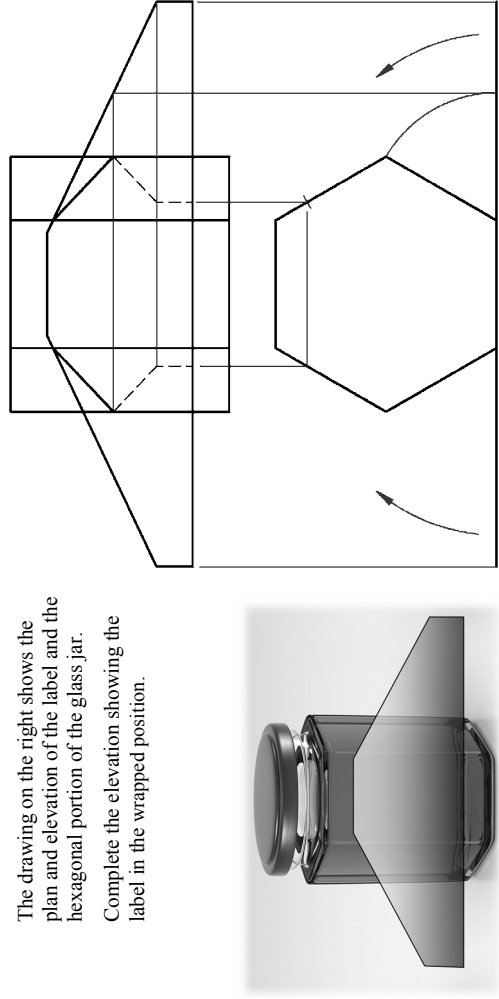

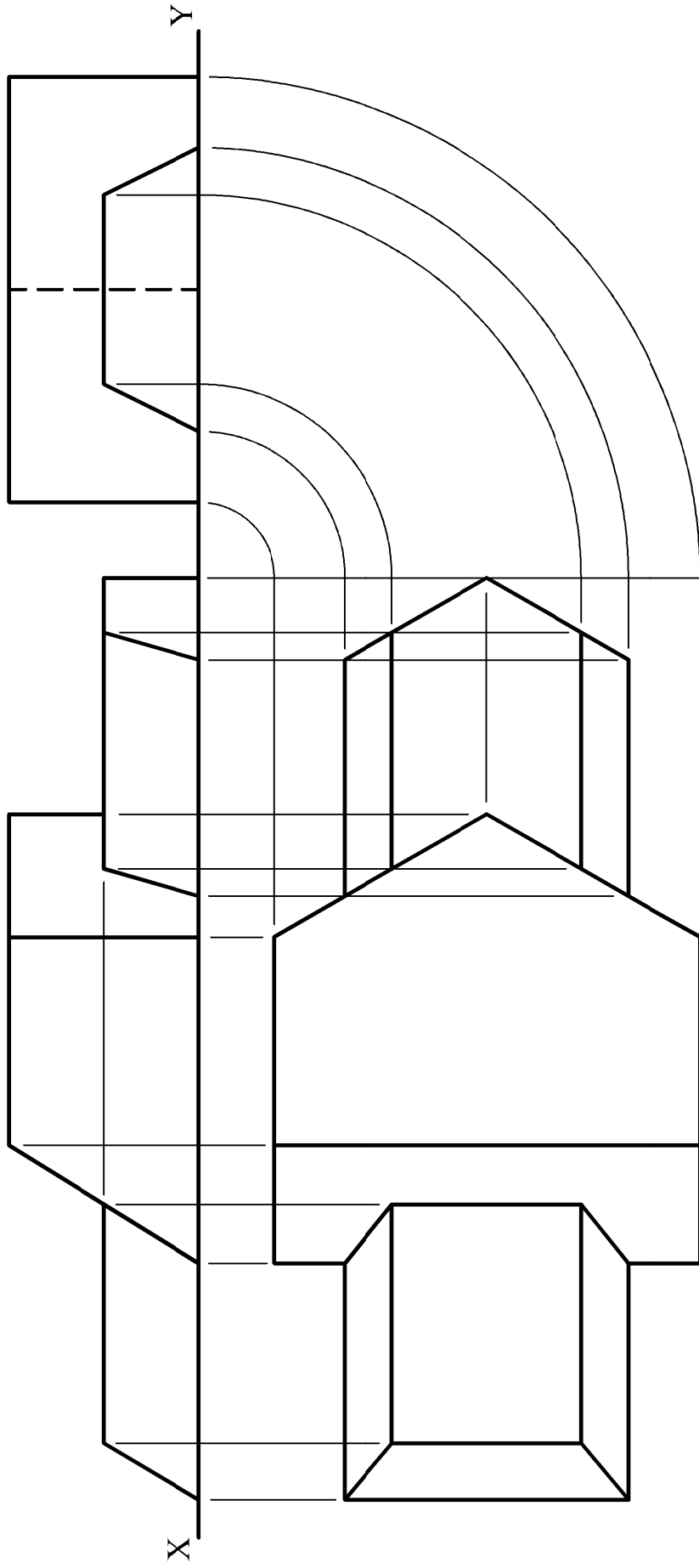

Design & Communication Graphics – Ord. Level

Marking Scheme

Question B-1

Scale: n/a June 2012

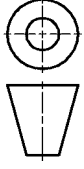

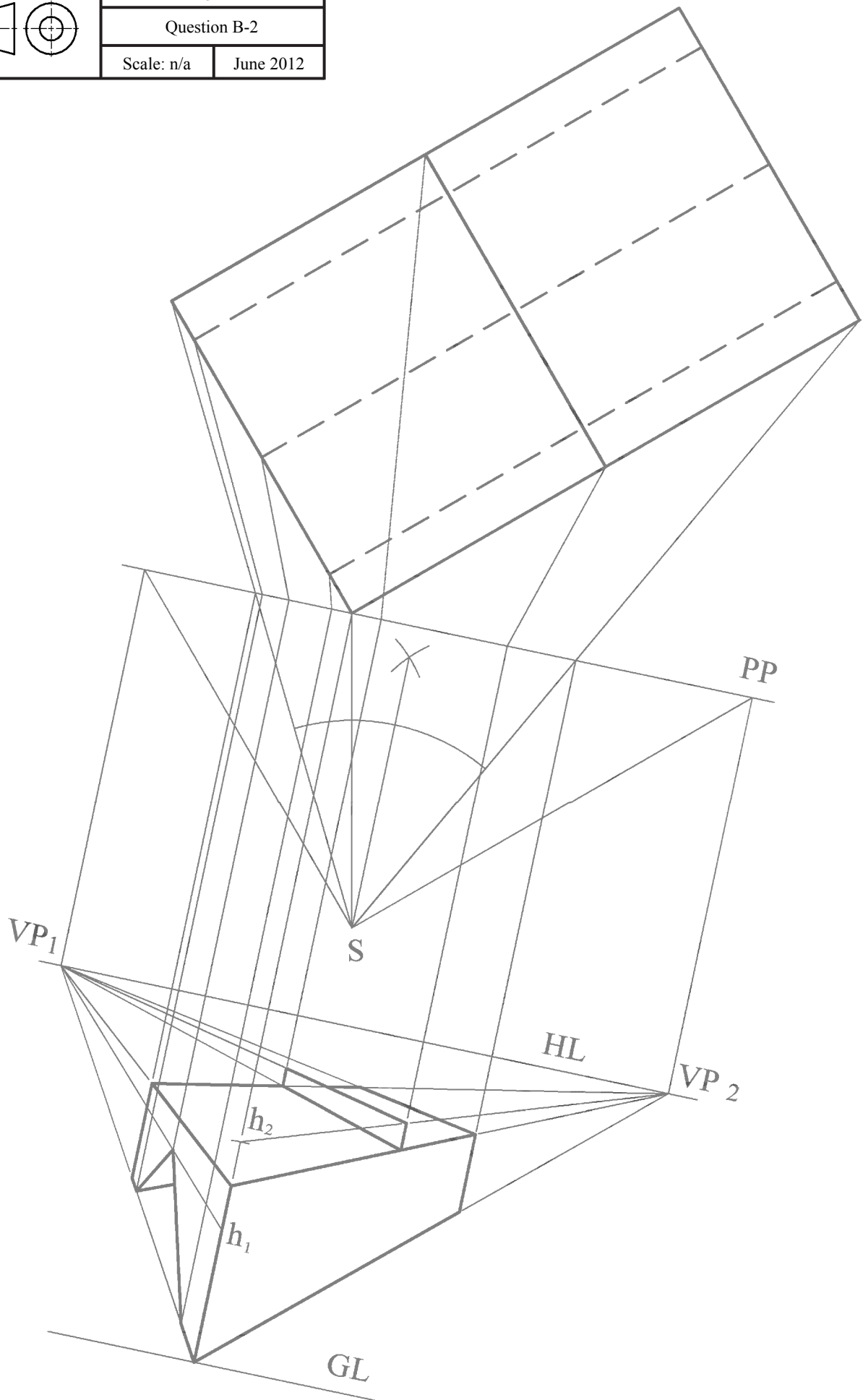
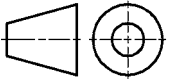

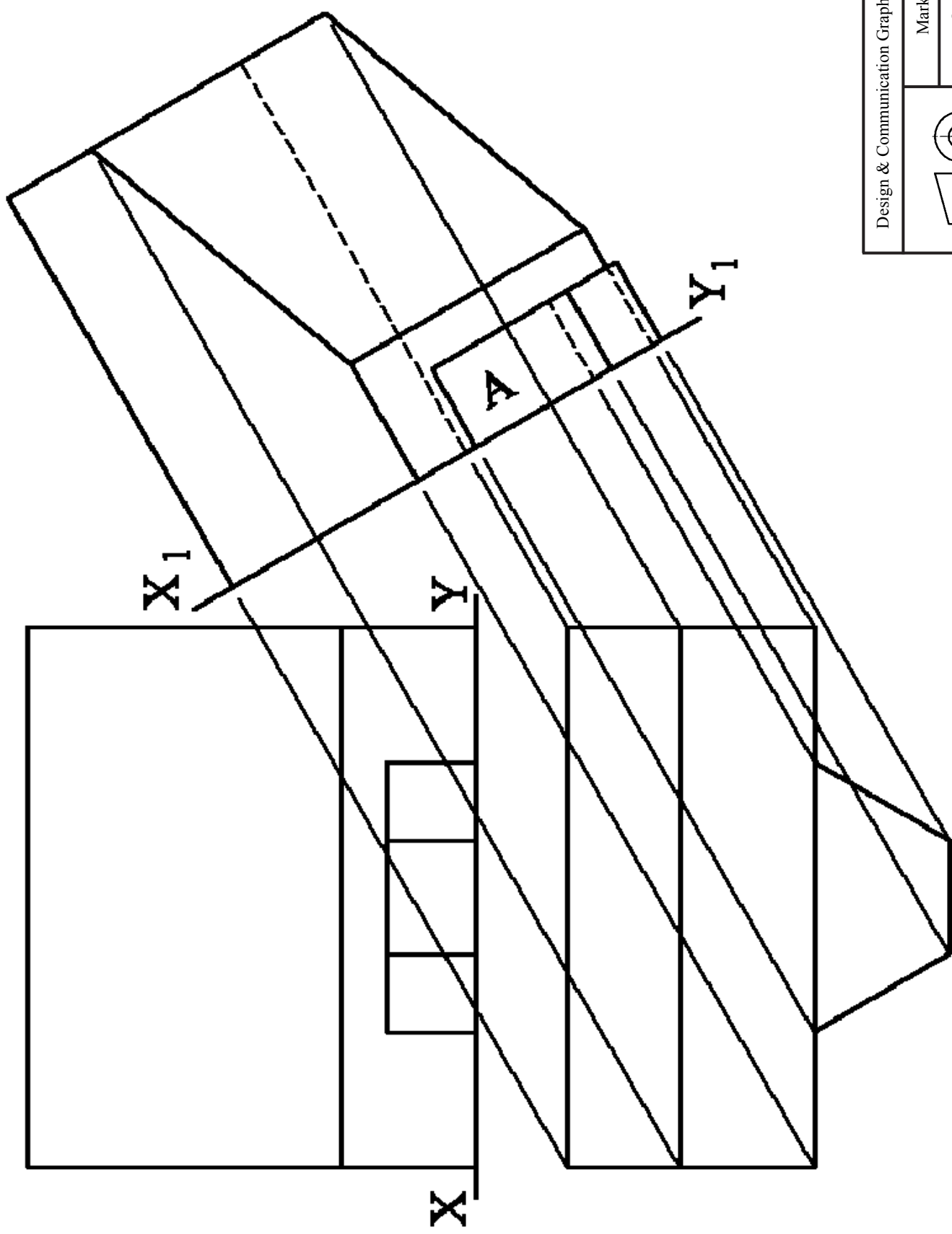
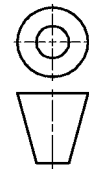

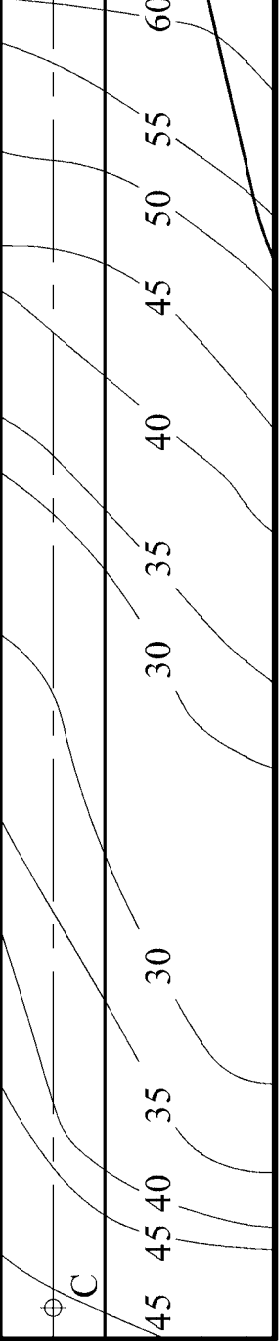
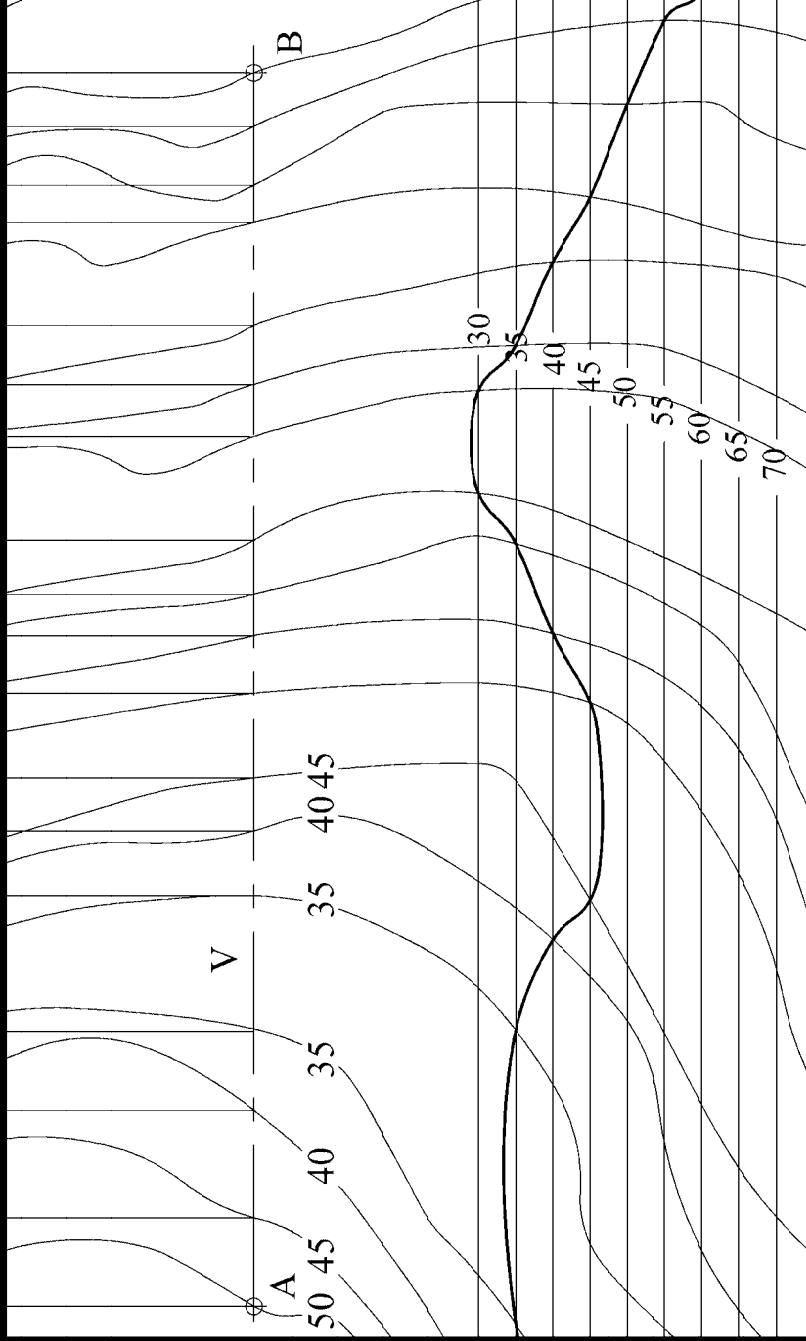
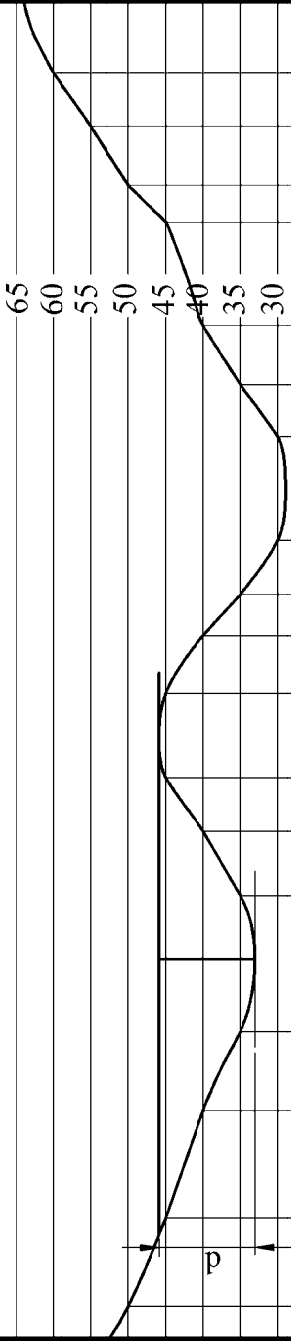
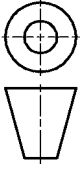

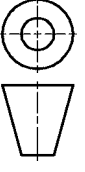
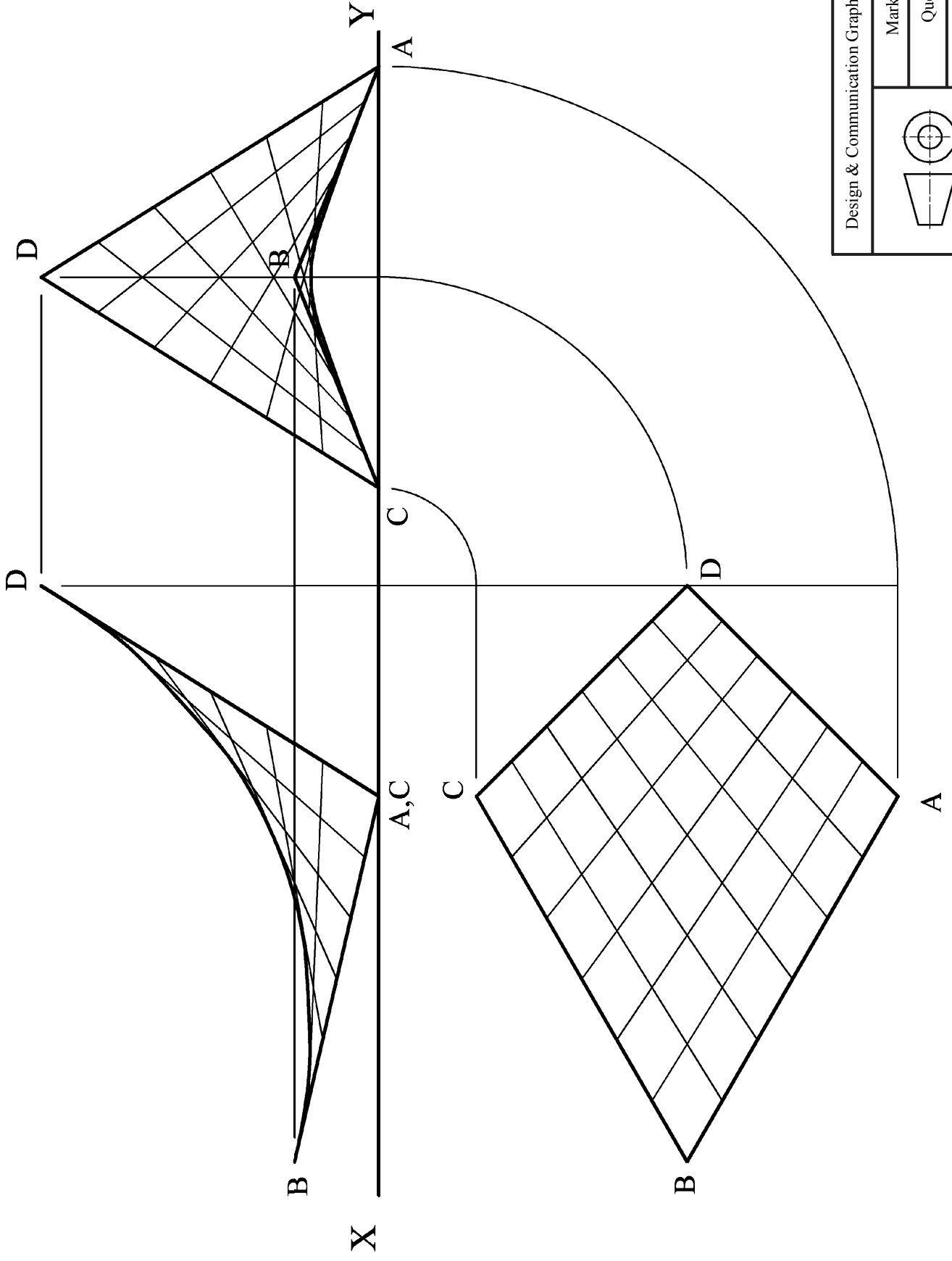

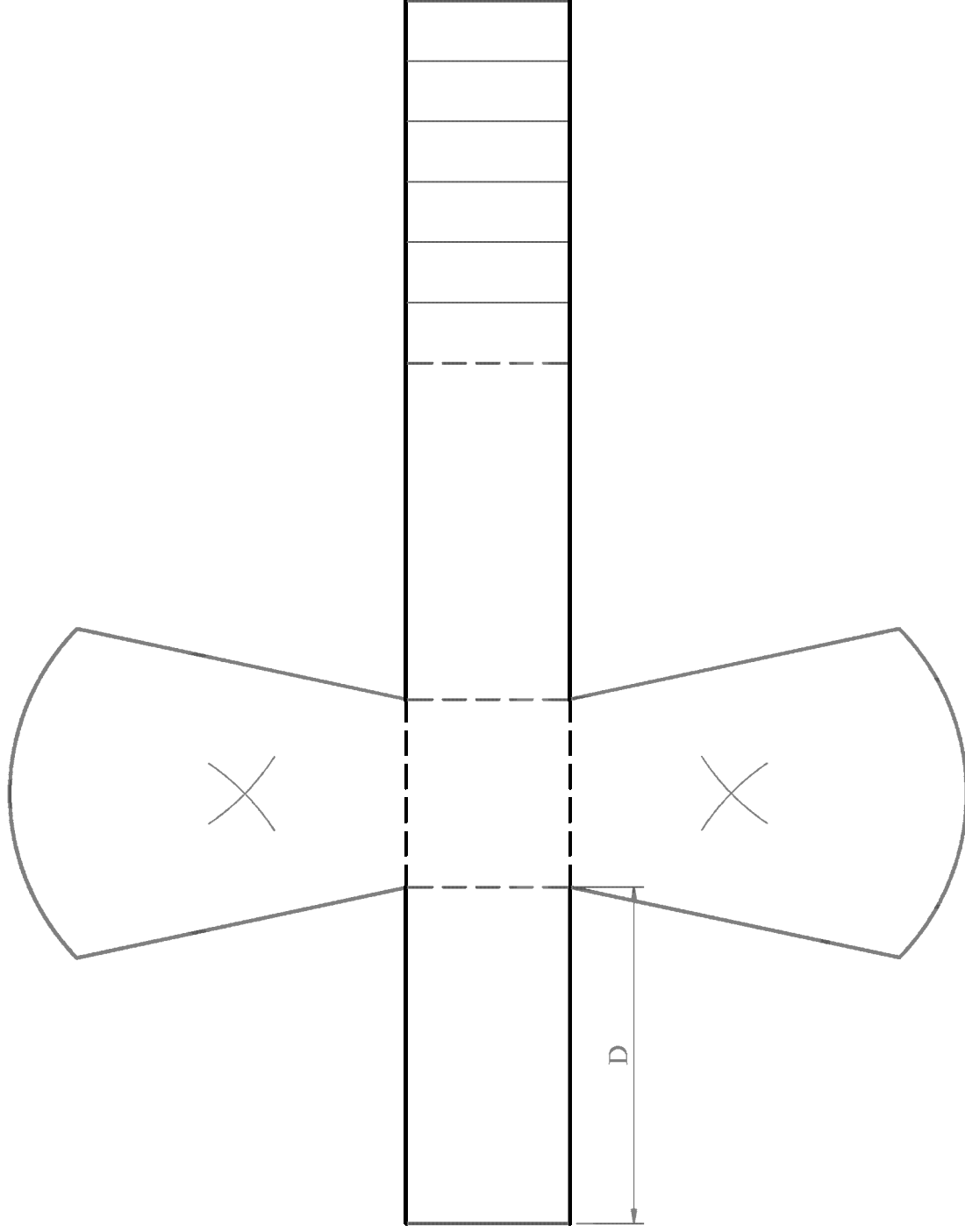
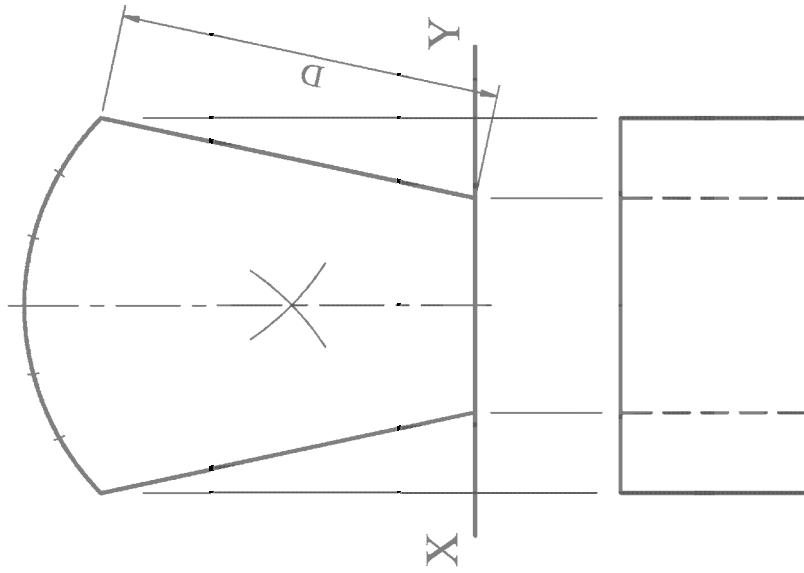
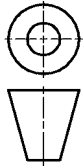

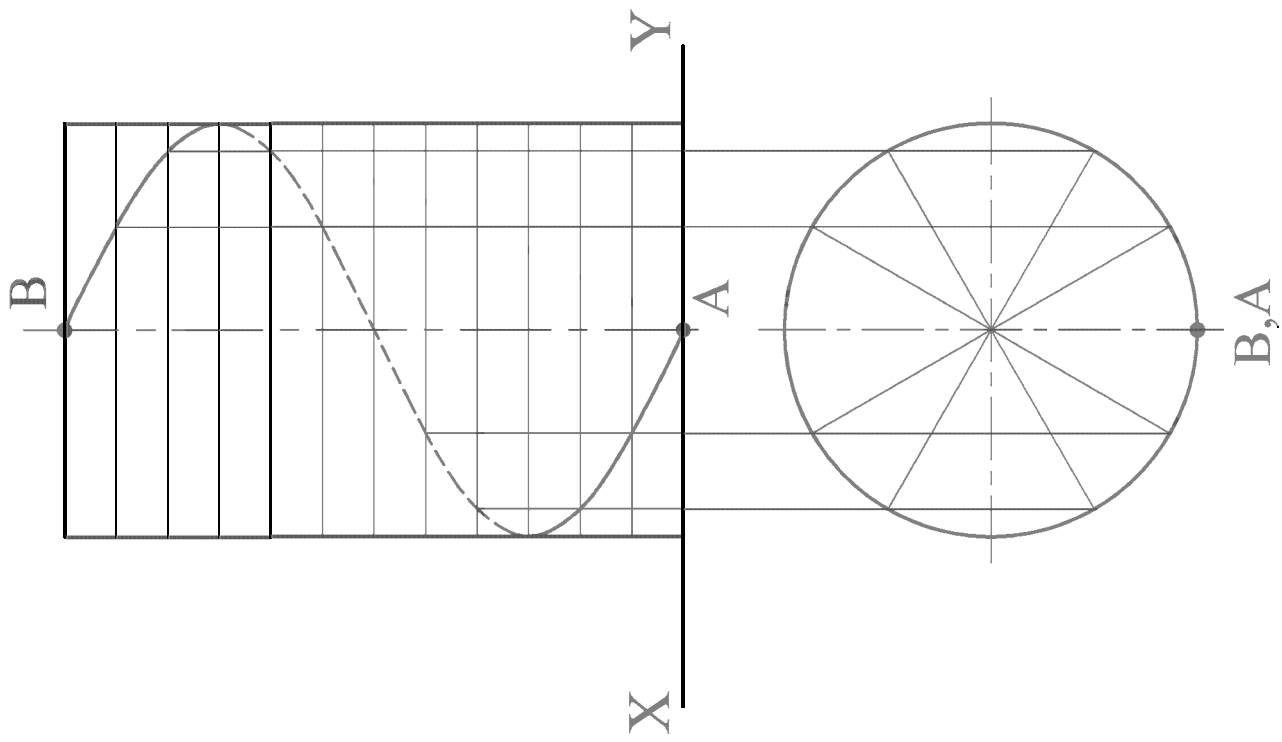
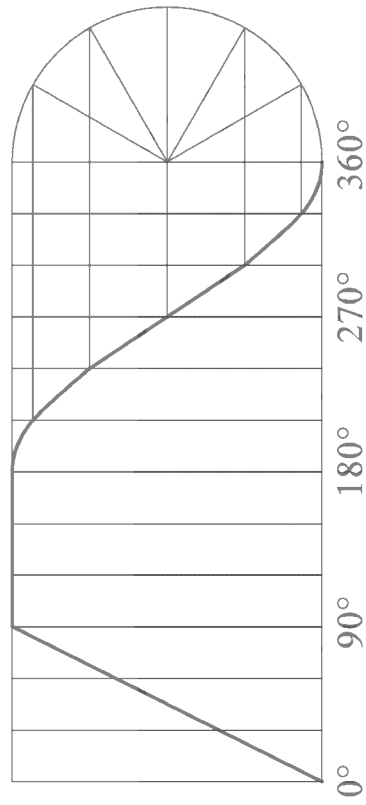

Design & Communication Graphics – Ord. Level

Marking Scheme

Question C-4

Scale: n/a June 2012

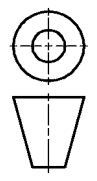

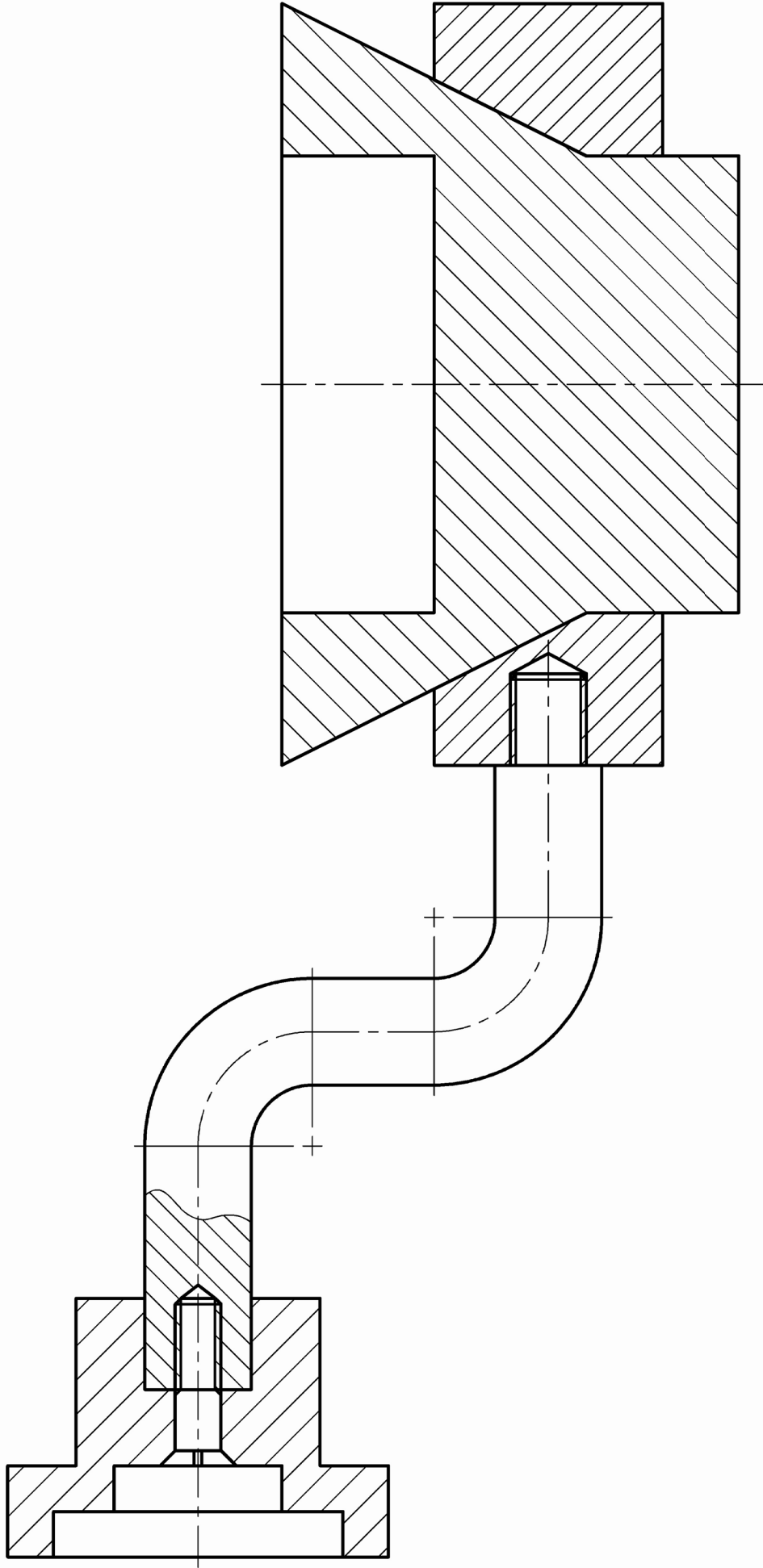

Design & Communication Graphics – Ord. Level	
Marking Scheme	
Question C-5	
Scale: n/a	June 2012

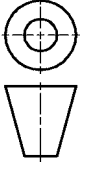



Coimisiún na Scrúduithe Stáit
State Examinations Commission

Design and Communication Graphics Student Assignment - Ordinary Level Assessment Sheet

Candidate Exam No.

Output	Marking criteria	Marks
1	Design Research - Exploration of main design features using primary & secondary research; Selection of appropriate graphics; Effective layout and presentation of information combining images, sketches & annotations	
	a) Extensive range of relevant criteria considered - excellent presentation	13 - 15
	b) Most relevant criteria considered - very good presentation	10 - 12
	c) Some relevant criteria considered - good presentation	7 - 9
	d) Limited criteria considered - fair presentation	4 - 6
	e) At least one criterion considered - poor presentation	0 - 3
2	Design Feature Comparison - Selection of two appropriate images; Main dimensions inserted; Comparison of main design features; Contrasting of main design features; Effective layout and presentation of information combining images, sketches & annotations	
	a) Extensive range of relevant criteria considered - excellent presentation	13 - 15
	b) Most relevant criteria considered - very good presentation	10 - 12
	c) Some relevant criteria considered - good presentation	7 - 9
	d) Limited criteria considered - fair presentation	4 - 6
	e) At least one criterion considered - poor presentation	0 - 3
3	Freehand Graphical Representation - Proportion; Form/Volume; Use of Tone/Line for effective rendering; Detailed communication of main design features to include 3D presentation quality drawing; Layout & presentation	
	a) Extensive range of relevant criteria considered - excellent presentation	17 - 20
	b) Most relevant criteria considered - very good presentation	13 - 16
	c) Some relevant criteria considered - good presentation	9 - 12
	d) Limited criteria considered - fair presentation	5 - 8
	e) At least one criterion considered - poor presentation	0 - 4
4	SolidWorks Parts, Assembly, Drawing and eDrawing files	
	• Adherence to required filing structure	3
	• Creation of a minimum of 3 Part files	6
	• Part models - Proficiency in Parametric CAD; Selection of most appropriate profile; Sketches fully defined; Features renamed; Appropriate type of extrusions used	12
	• Assembly - Creation of Assembly environment; Accuracy of parts to facilitate correct assembly; Correct mating of parts; Application of appropriate appearances	6
	• Factor of difficulty	3
	• eDrawing of CAD model	3
5	Hardcopy outputs from SolidWorks - Detailed orthographic views of the Assembly; Rendered pictorial view of the Assembly; Exploded view of the CAD model; Inclusion of main dimensions; Scaling, layout and presentation	
	a) Extensive range of relevant criteria considered - excellent presentation	17 - 20
	b) Most relevant criteria considered - very good presentation	13 - 16
	c) Some relevant criteria considered - good presentation	9 - 12
	d) Limited criteria considered - fair presentation	5 - 8
	e) At least one criterion considered - poor presentation	0 - 4
6	Photorealistic Representation	
	Produce photorealistic computer generated images of the artefact	7
7	Graphical exploration of design solutions - Exploration of theme/possible solution(s); Justification of chosen solution(s); Use of appropriate images/graphics; Effective layout and presentation of information combining images, sketches & annotations	
	a) Extensive range of relevant criteria considered - excellent presentation	17 - 20
	b) Most relevant criteria considered - very good presentation	13 - 16
	c) Some relevant criteria considered - good presentation	9 - 12
	d) Limited criteria considered - fair presentation	5 - 8
	e) At least one criterion considered - poor presentation	0 - 4
8	Presentation of Modification/Concept Design - Proportion, Form/Volume, Use of Tone/Line for effective rendering, Detailed communication of modified/concept design features; Layout and presentation	
	a) Extensive range of relevant criteria considered - excellent presentation	9 - 10
	b) Most relevant criteria considered - very good presentation	7 - 8
	c) Some relevant criteria considered - good presentation	5 - 6
	d) Limited criteria considered - fair presentation	3 - 4
	e) At least one criterion considered - poor presentation	0 - 2
9	Hardcopy outputs from SolidWorks - CAD model; Detailed orthographic views of the proposed solution; Rendered pictorial view of the CAD model, Inclusion of main dimensions; Scaling, layout and presentation	
	• Application of CAD skills	5
	a) Extensive range of relevant criteria considered - excellent presentation	13 - 15
	b) Most relevant criteria considered - very good presentation	10 - 12
	c) Some relevant criteria considered - good presentation	7 - 9
	d) Limited criteria considered - fair presentation	4 - 6
	e) At least one criterion considered - poor presentation	0 - 3
Sub-total		
	Marks deducted for pages in excess of maximum	
		Total

