



Coimisiún na Scrúduithe Stáit
State Examinations Commission

Leaving Certificate Examination, 2011

Design & Communication Graphics
Ordinary Level

Section A (60 marks)

Friday, 17 June

Afternoon, 2.00 - 5.00

This examination is divided into three sections:

- SECTION A (Core - Short Questions)
 SECTION B (Core - Long Questions)
 SECTION C (Applied Graphics - Long Questions)

- SECTION A**
- Four questions are presented.
 - Answer **any three** on the A3 sheet overleaf.
 - All questions in Section A carry **20 marks** each.

- SECTION B**
- Three questions are presented.
 - Answer **any two** on drawing paper.
 - All questions in Section B carry **45 marks** each.

- SECTION C**
- Five questions are presented.
 - Answer **any two** (i.e. the options you have studied) on drawing paper.
 - All questions in Section C carry **45 marks** each.

General Instructions:

- *Construction lines must be shown on all solutions.*
- *Write the question number distinctly on the answer paper in Sections B and C.*
- *Work on one side of the drawing paper only.*
- *All dimensions are given in metres or millimetres.*
- *Write your Examination number in the box below and on all other sheets used.*

Examination Number:

SECTION A - Core - Answer Any Three of the questions on this A3 sheet

A-1. The 3D graphic below shows a traditional Irish telephone box.

A set of isometric axes and a partially completed drawing of the box are shown on the right. The elevation and plan of the box have been positioned relative to the axes as shown.

Complete the axonometric projection.

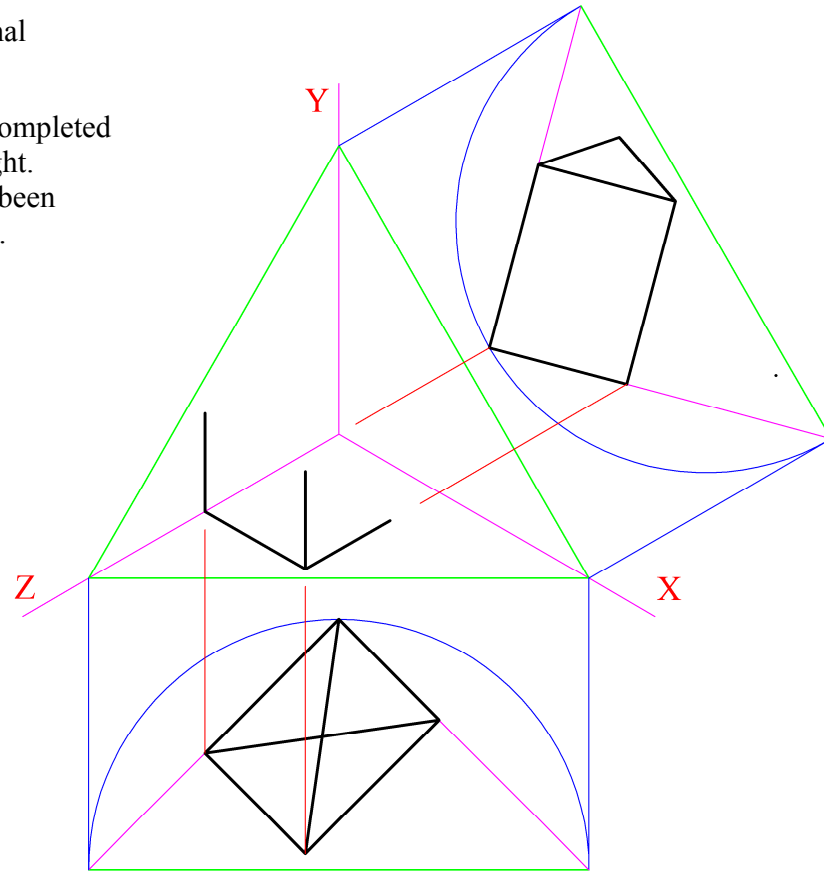

A-3. The 3D graphic below shows Dublin's newest bridge, which is in the shape of a semi-parabola.

The drawing on the right shows a rectangle **ABCV** with a portion of the parabola inscribed.

- Locate the remaining points on the curve and complete the semi-parabola.
- Draw the lower half of the parabola, representing the reflection in the water, as shown below.

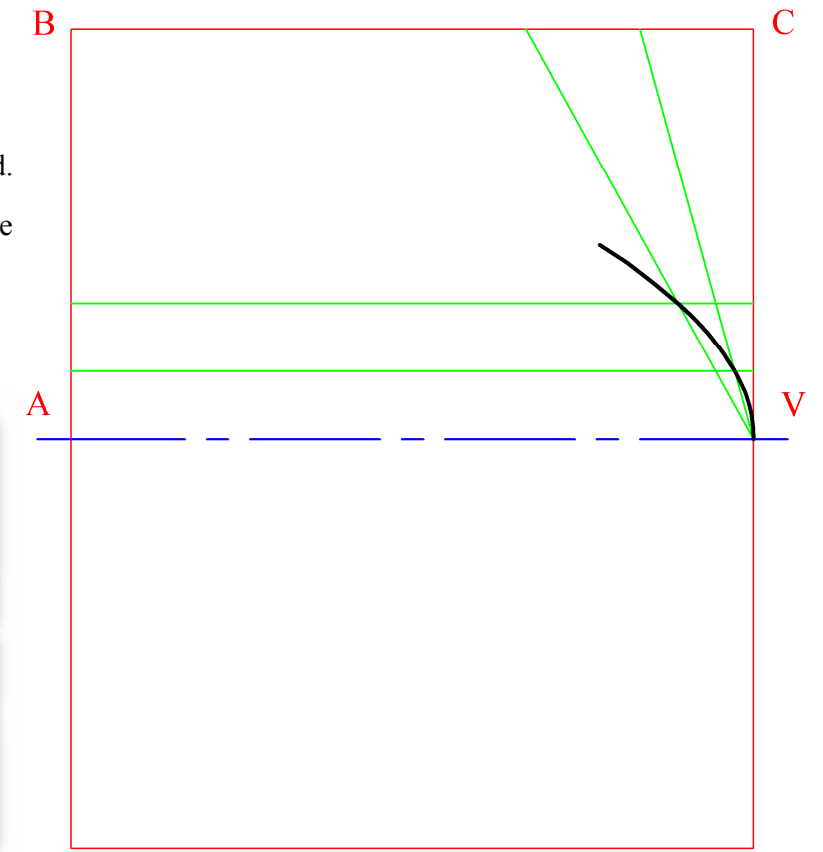

A-2. The 3D graphic below shows a post box. The plan and incomplete elevation of the box are shown on the right.

- Complete the elevation.
- Draw an auxiliary view of the post box, on the given X_1Y_1 , which will show the true angle between the surfaces **A** and **B**.

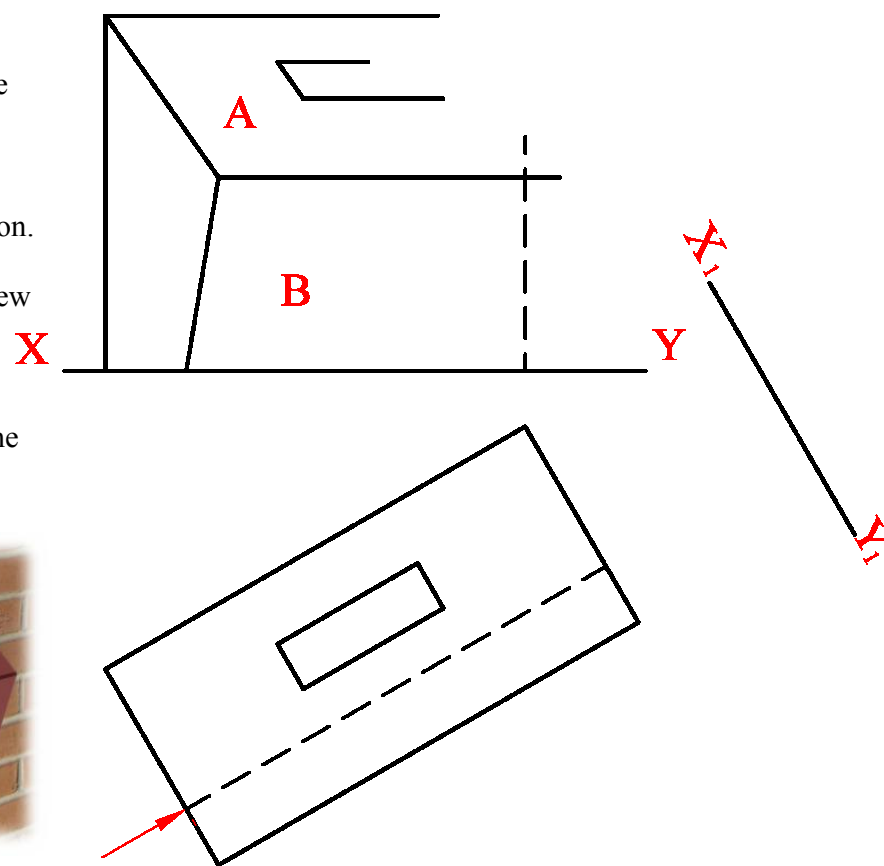
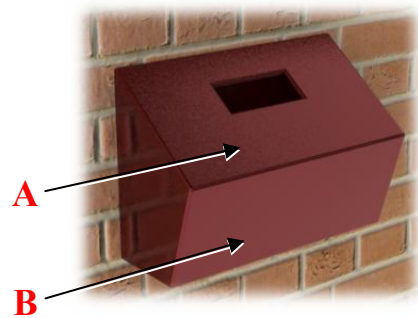

A-4. The 3D graphic below shows three candles which are in contact. The arrangement includes a cone and two cylinders. All three solids rest on the horizontal plane.

The drawing on the right shows the plan and elevation of the cone **A**. Cylinder **B** is shown in the plan and cylinder **C** is shown in the elevation.

- Draw the elevation of cylinder **B**.
- Draw the plan of cylinder **C**.

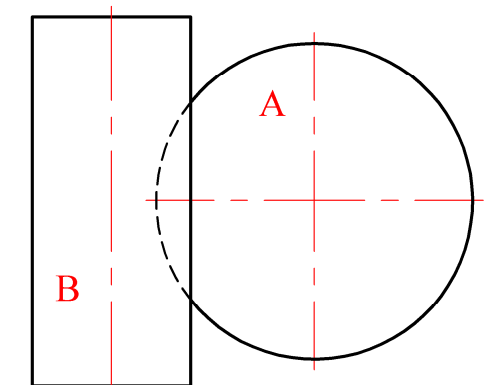
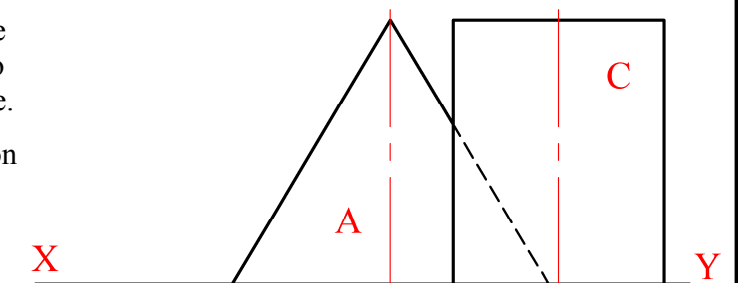
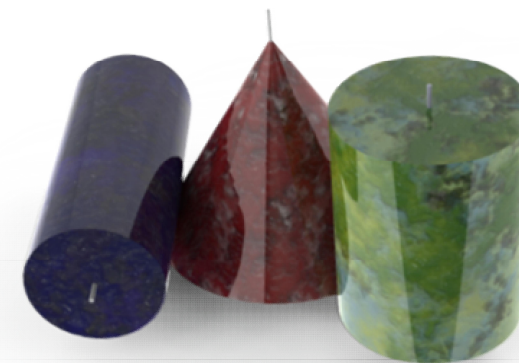

This Contour Map is part of Section C and should only be used for the answering of the Geologic Geometry Option (Question C-1).

