



Coimisiún na Scrúduithe Stáit
State Examinations Commission

LEAVING CERTIFICATE 2009

MARKING SCHEME

**DESIGN & COMMUNICATION
GRAPHICS**

ORDINARY LEVEL

QUESTION A-1

MARKS

(i) Division of DV and VC	2
(ii) Corresponding division of AD and BC	2
(iii) Lines parallel to axis.....	2
(iv) Lines radiating from V	1
(v) Identify points on curve	2
(vi) Draw curve	9
(vii) <i>Presentation</i>	<u>2</u>

Total = 20

QUESTION A-2

MARKS

(i) Set up axes in plan (1,1,1)	3
(ii) Draw plan (positioned relative to axes)	3
(iii) Projections from elevation	3
(iv) Projections from plan	3
(v) Identify points on axonometric projection	3
(vi) Complete axonometric projection	3
(vii) <i>Presentation</i>	<u>2</u>

Total = 20

QUESTION A-3

	<u>MARKS</u>
(a) Completion of elevation (15)	
(i) Projections to elevation	4
(ii) Identify points in elevation	2
(iii) Complete elevation	9
(b) True shape (3)	
(iv) Establish correct widths	1
(v) Establish correct lengths	1
(vi) Completion of true shape	1
(vii) <i>Presentation</i>	<u>2</u>
Total = 20	

QUESTION A-4

	<u>MARKS</u>
(i) Division of circle in plan	4
(ii) Projection of divisions to elevation	2
(iii) Mark corresponding divisions on plan of label	2
(iv) Projection of divisions to elevation of label	2
(v) Identify points on envelopment	2
(vi) Drawing of envelopment (Lines)	3
(vii) Drawing of envelopment (Curves)	3
(viii) <i>Presentation</i>	<u>2</u>
Total = 20	

QUESTION B-1**MARKS****(a) Plan and elevation (31)**

(i) Plan of pier	8
(ii) Plan of wall	8
(iii) Elevation of pier	7
(iv) Elevation of wall	8

(b) Auxiliary elevation (10)

(v) X_1Y_1 parallel to plan of surface A	2
(vi) Projections from plan	2
(vii) Transfer heights from elevation	2
(viii) Draw surface A	2
(ix) Complete auxiliary elevation	2
(x) <i>Presentation</i>	4

Total = 45

QUESTION B-2

MARKS

(a) Plan (12)	
(i) Plan of structure.....	12
 (b) Perspective drawing (29)	
(ii) Plan of spectator, PP, VP ₁ and VP ₂	3
(iii) Elevation of GL, HL, VP ₁ and VP ₂	4
(iv) Sight lines from spectator to plan	7
 <i>Entrance tunnel</i>	
(v) Perspective of bottom edges	4
(vi) Establish heights.....	2
(vii) Completion of entrance tunnel	2
 <i>Main structure</i>	
(viii) Perspective of bottom edges	2
(ix) Establish heights.....	2
(x) Perspective of window	1
(xi) Completion of main structure.....	2
(xii) <i>Presentation</i>	4

Total = 45

QUESTION B-3

MARKS

Outline plan, elevation and elevation (27)

(i) Given Plan	10
(ii) Given elevation	10
(iii) End elevation.....	7

Interpenetration (14)

(iv) Projections from LHS of elevation	2
(v) Locate points in plan	3
(vi) Complete LHS of plan	3
(vii) Projections from RHS of plan & end elevation	2
(viii) Locate points in elevation	2
(ix) Complete RHS of elevation	1
(x) Hidden detail	1
(xi) <i>Presentation</i>	4

Total = 45

QUESTION C-1

MARKS

- (a) Profile (19)**
- (i) Measure heights and draw horizontal lines6
 - (ii) Projections from intersections between line AB and contours5
 - (iii) Draw outline of profile8
- (b) Observation tower (9)**
- (iv) Draw tangent from B to profile6
 - (v) Indicate tower height3
- (c) Earthworks for roadway (13)**
- (vi) Parallel lines at 5m intervals5
 - (vii) Identify points on earthworks curve4
 - (viii) Draw earthworks curve4
 - (ix) *Presentation*4

Total = 45

QUESTION C-2

MARKS

(a) Elevation and Plan (20)

- (i) Outline of surface ABCD in elevation4
- (ii) Elements in elevation (incl. division)5
- (iii) Outline of surface ABCD in plan4
- (iv) Elements in plan (incl. division)5
- (v) Curves in elevation and plan2

End view of Hyperbolic Paraboloid (10)

- (vi) Determine heights and widths for surface ABCD5
- (vii) Draw the outline of surface ABCD2
- (viii) Elements in end view (incl. curve)3

(b) Triangular entrance (9)

- (ix) Elevation of entrance.....2
- (x) End view of entrance.....2
- (xi) Intersection point in plan2
- (xii) Plan of entrance3

Completion (2)

- (xiii) Complete projections of main structure2
- (xiv) *Presentation*4

Total = 45

QUESTION C-3

MARKS

(a) Plan and Elevation (18)	
(i) Given plan	8
(ii) Outline elevation	6
(iii) Complete elevation (circle)	4
(b) Surface development (21)	
(iv) Development of back surface	6
(v) Development of top and bottom surfaces	4
(vi) Development of flat side surfaces	4
(vii) Division of circumference	1
(viii) Development of curved surface	2
(ix) Establish 4 quadrant points on curve on surface dev.	2
(x) Additional points on curve on surface dev.	1
(xi) Draw curve	1
(c) Size of rectangular sheet (2)	
(xii) Rectangle enclosing development.....	1
(xiii) Indicate dimensions	1
(xiv) <i>Presentation</i>	4

Total = 45

QUESTION C-4

MARKS

(a) Displacement Diagram (22)

- (i) 360° Division (widths on displacement diag.)3
- (ii) Establish follower position at A, B, C and D5
- (iii) A-B: Uniform Acceleration & Retardation ... (3,1)4
- (iv) B-C: Uniform Velocity4
- (v) C-D: Dwell2
- (vi) D-A: Simple Harmonic Motion ... (3,1)4

(b) Link Mechanism (19)

- (vii) Setup line diagram (O, E, P & F)8
- (viii) Draw Circle about O3
- (ix) Division of circle2
- (x) Lines from circle divisions through P2
- (xi) Points on locus2
- (xii) Draw locus2

- (xiii) *Presentation*4

Total = 45

QUESTION C-5

MARKS

(a) Sectional elevation (35)

Assembly (6)

(i) Relative positioning of components 6

Wall Anchor (7)

(ii) Outline 4

(iii) Holes 3

Link Arm (5)

(iv) Outline 3

(v) Holes 2

TV Plate (5)

(vi) Outline 2

(vii) Construction for bottom of hexagon 2

(viii) Hole 1

Bolts, Nuts and Washers (6)

(ix) Heads (incl. curves) 2

(x) Shafts (incl. threads) 2

(xi) Nuts and washers (incl. curves) 2

Drawing Completion (6)

(xii) Hatching and Centrelines ... (3,3) 6

(b) Distance in closed position (6)

(xiii) Initial setup of Wall Anchor and Link Arm 3

(xiv) Location of contact point between Link Arm and Wall (P_1) 1

(xv) Location of centre Q relative to P_1 1

(xvi) Completion of solution and indication of required distance 1

(xvii) *Presentation* 4

Total = 45

SECTION A - Core - Answer Any Three of the questions on this A3 sheet

A-1. The 3D graphic below shows a typical satellite dish which is in the shape of a parabola.

On the drawing on the right draw the outline of the parabola in the rectangle ABCD. The vertex of the parabola should be positioned at V.

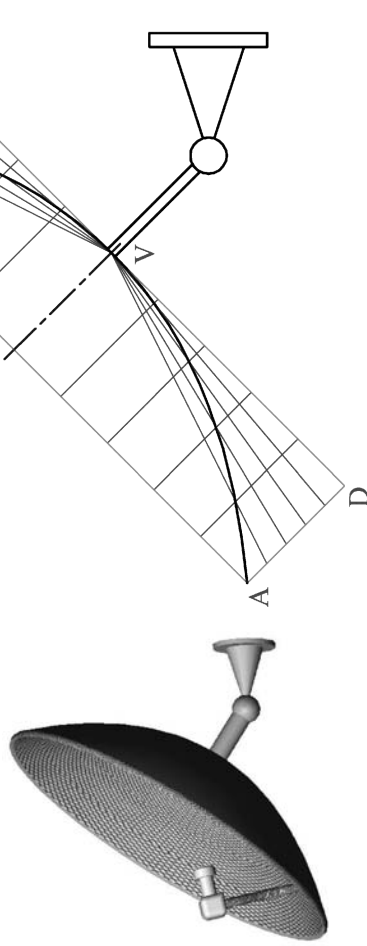

A-3. The 3D Graphic below shows a trophy consisting of a shaped glass pyramid on a marble base. The projections of the glass portion are shown on the right. The pyramid is cut by the oblique plane VTH as shown.

- (a) Complete the elevation.
- (b) Draw the true shape of the cut surface of the pyramid.

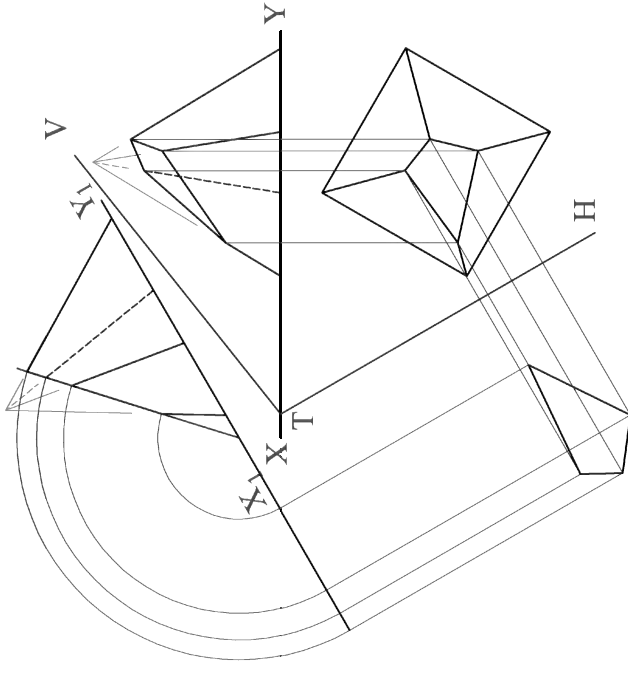
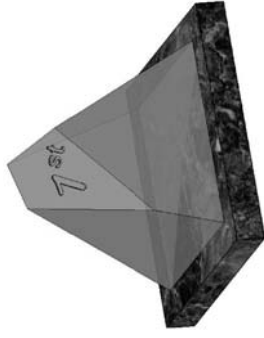

A-2. The plan and elevation of a garden seat are shown below. A 3D graphic is also given.

A set of isometric axes is shown on the right and the elevation of the object has been positioned relative to the axes as shown.

Draw the plan in its correct position and complete the axonometric projection.

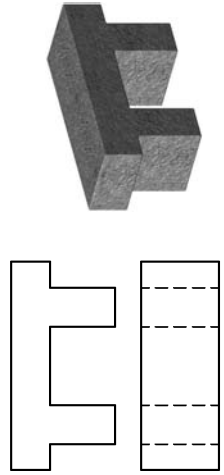

A-4. The 3D graphic below shows a glass jar and a label which is to be wrapped around it.

The drawing on the right shows the plan and elevation of the label and the cylindrical portion of the glass jar.

Complete the elevation showing the label in the wrapped position.

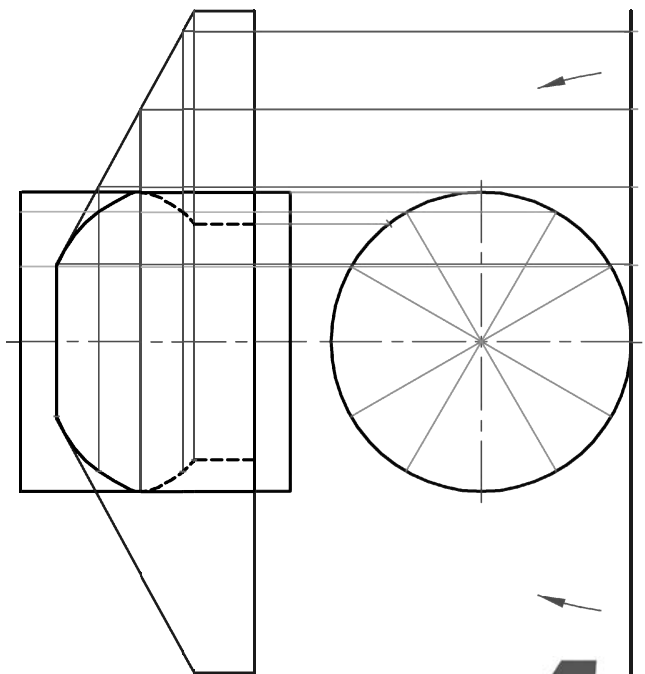

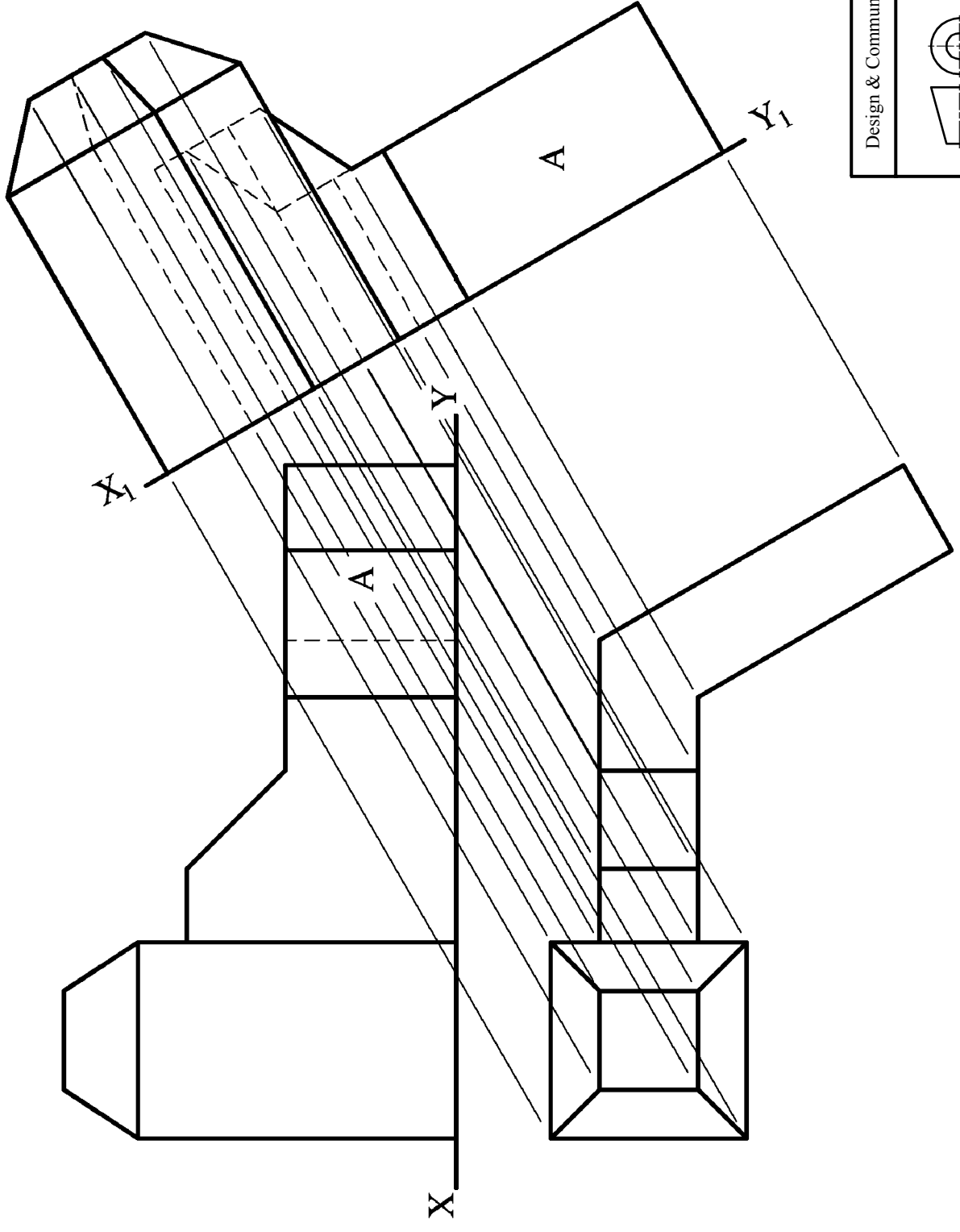

Design & Communication Graphics – Ord. Level	
Marking Scheme	
Question B-1	
Scale: n/a	June 2009

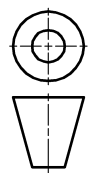

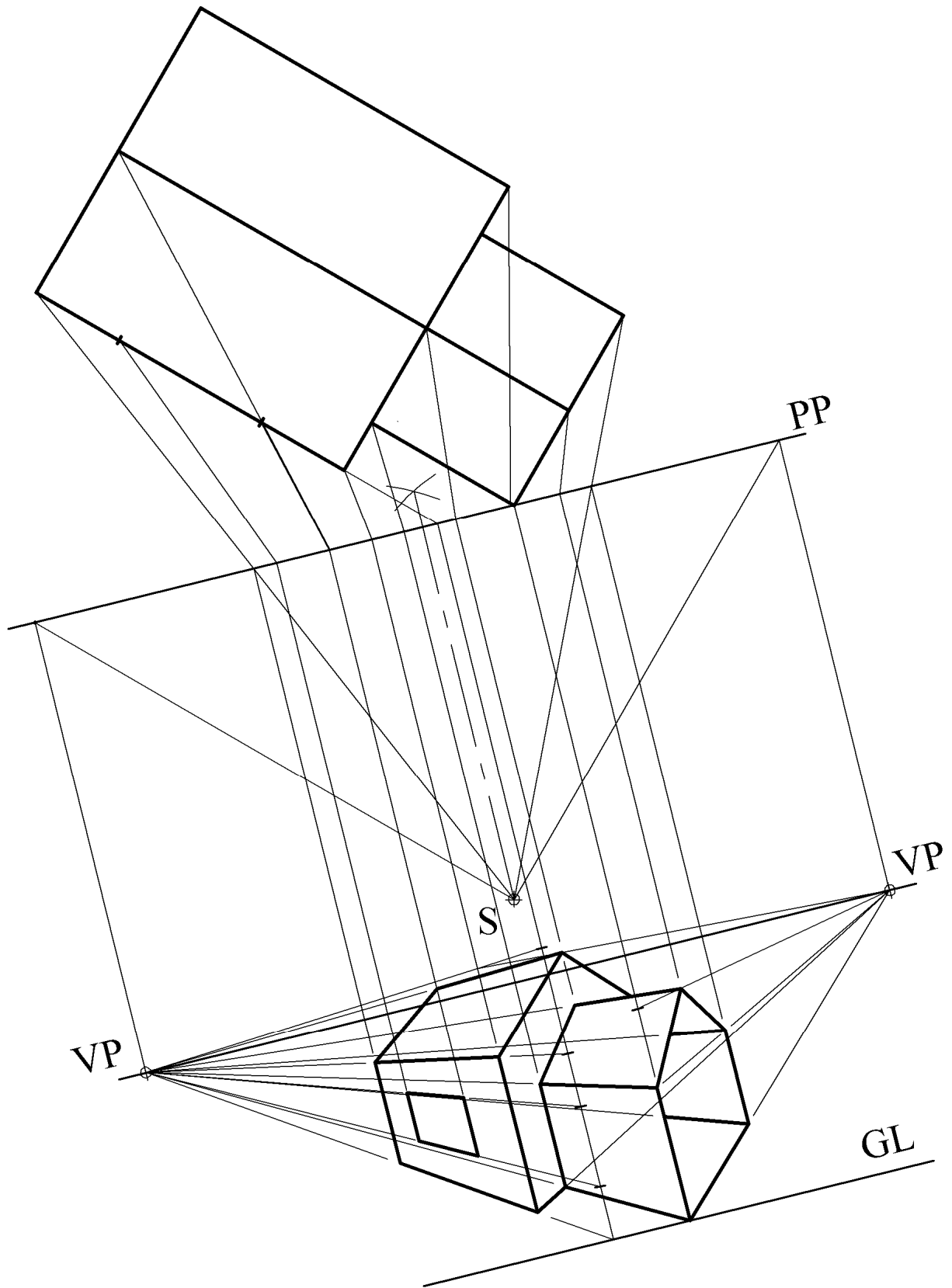

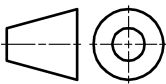
Design & Communication Graphics – Ord. Level	
	Marking Scheme
	Question B-2
	Scale: n/a
	June 2009

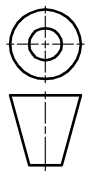
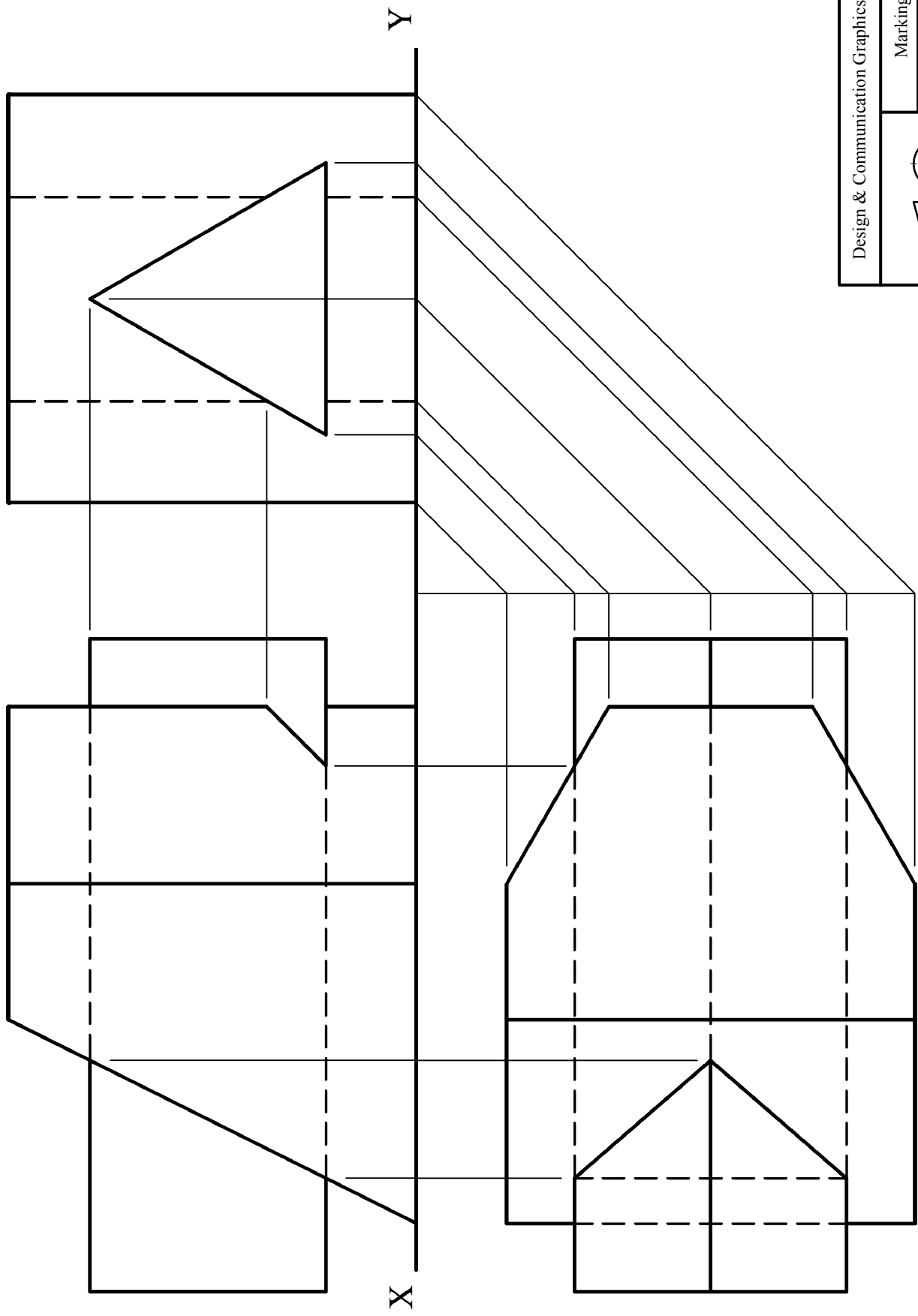

Design & Communication Graphics – Ord. Level

Marking Scheme

Question C-1

Scale: n/a June 2009

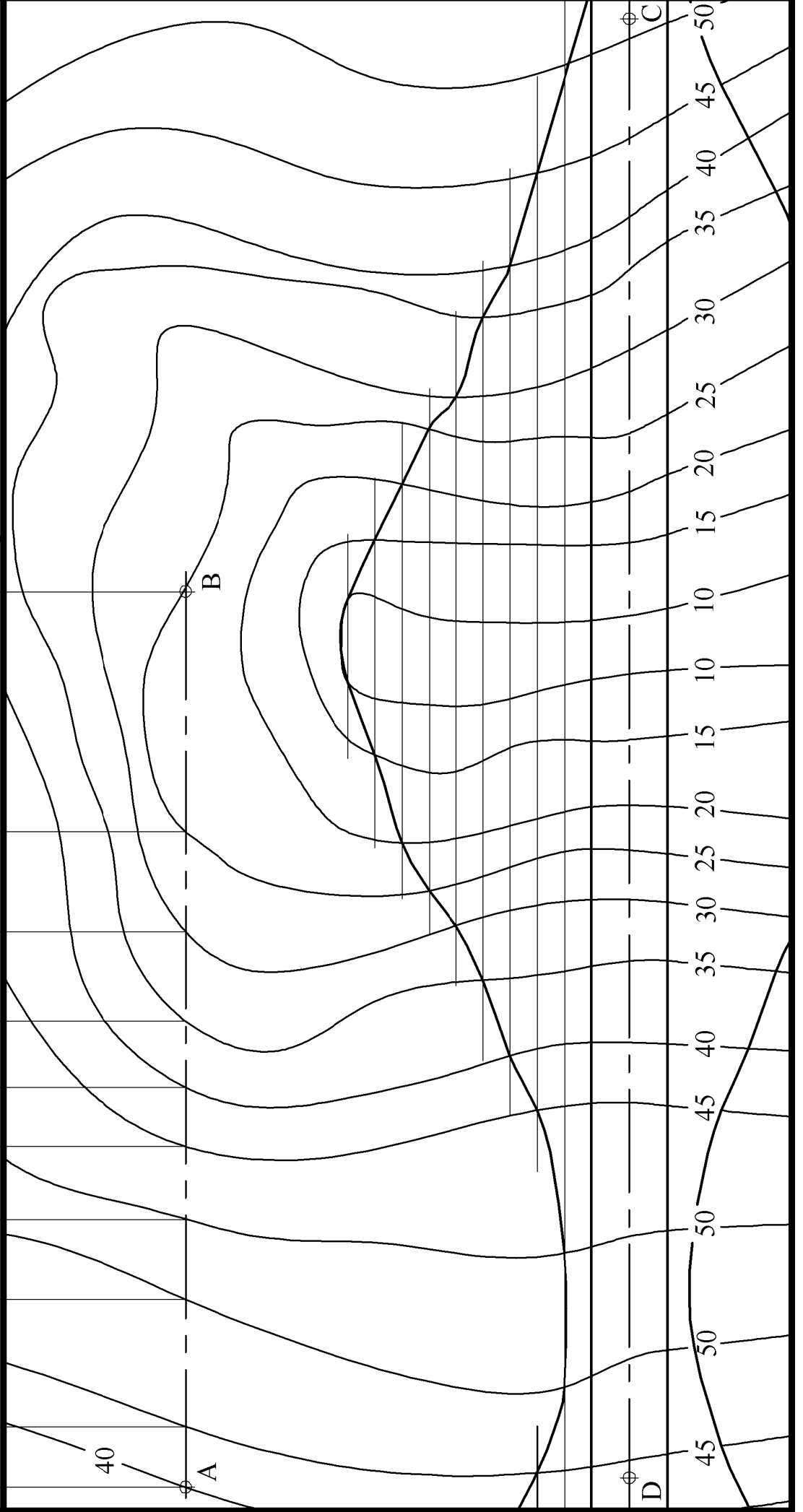
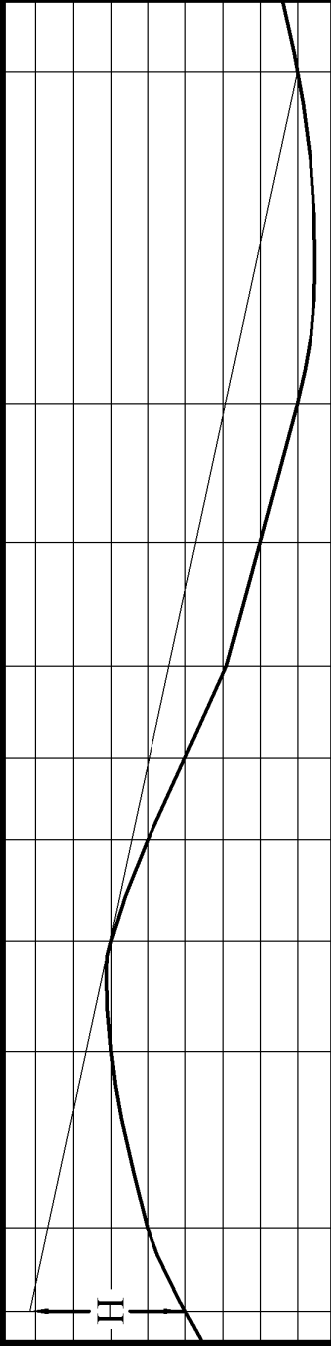
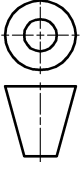

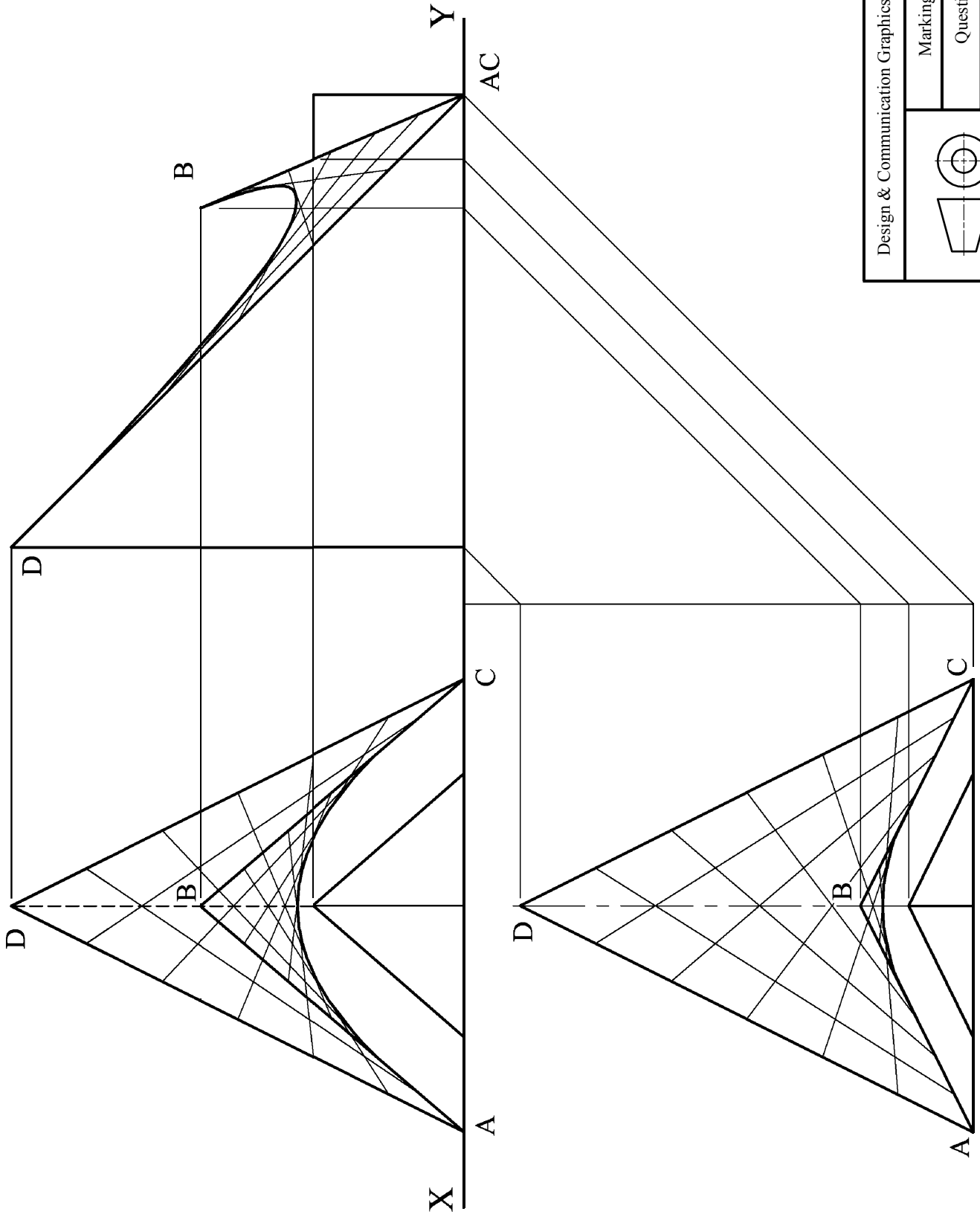

Design & Communication Graphics – Ord. Level

Marking Scheme

Question C-2

Scale: n/a June 2009

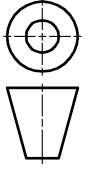

2170

2200

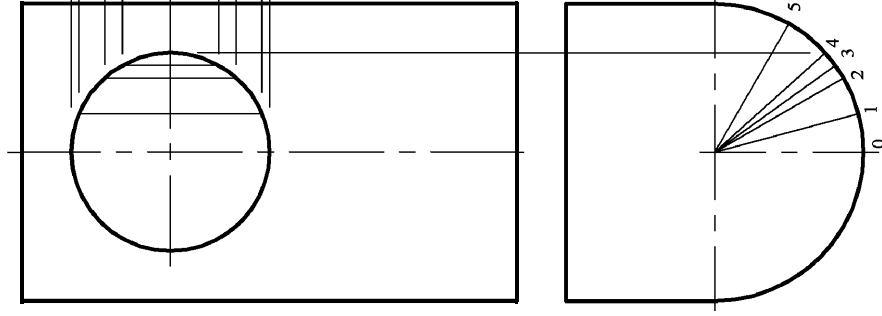
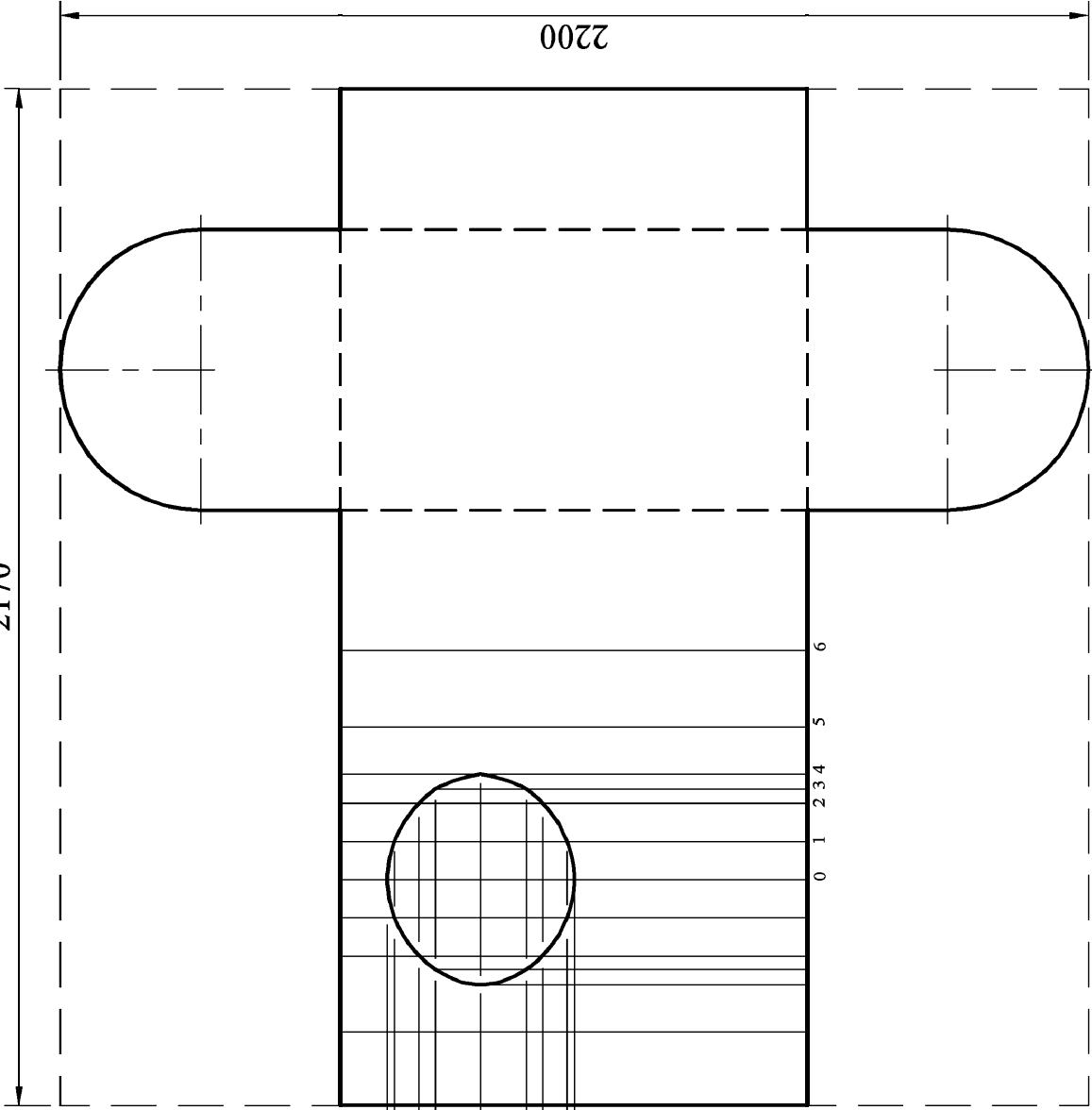

Design & Communication Graphics – Ord. Level	
Marking Scheme	Question C-3
Scale: n/a	
June 2009	

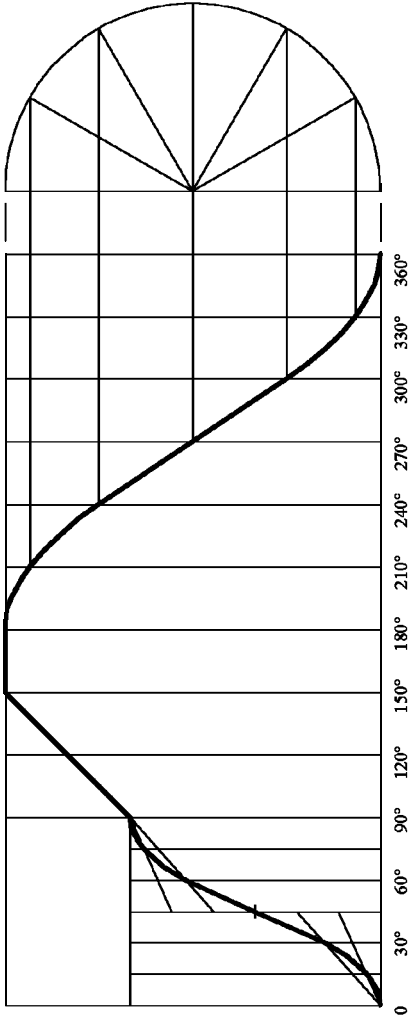

Part (a)

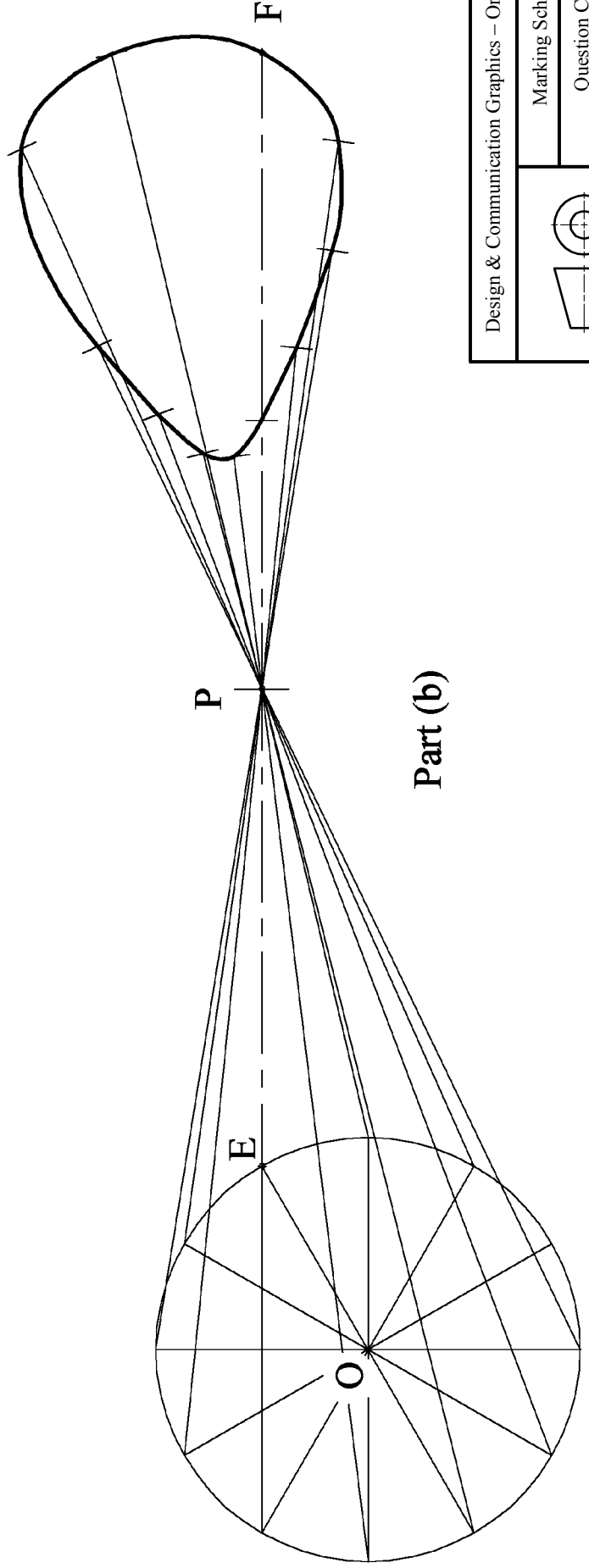

Part (b)

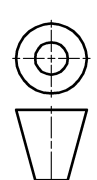
Design & Communication Graphics – Ord. Level	
	
Marking Scheme	Question C-4
Scale: n/a	June 2009

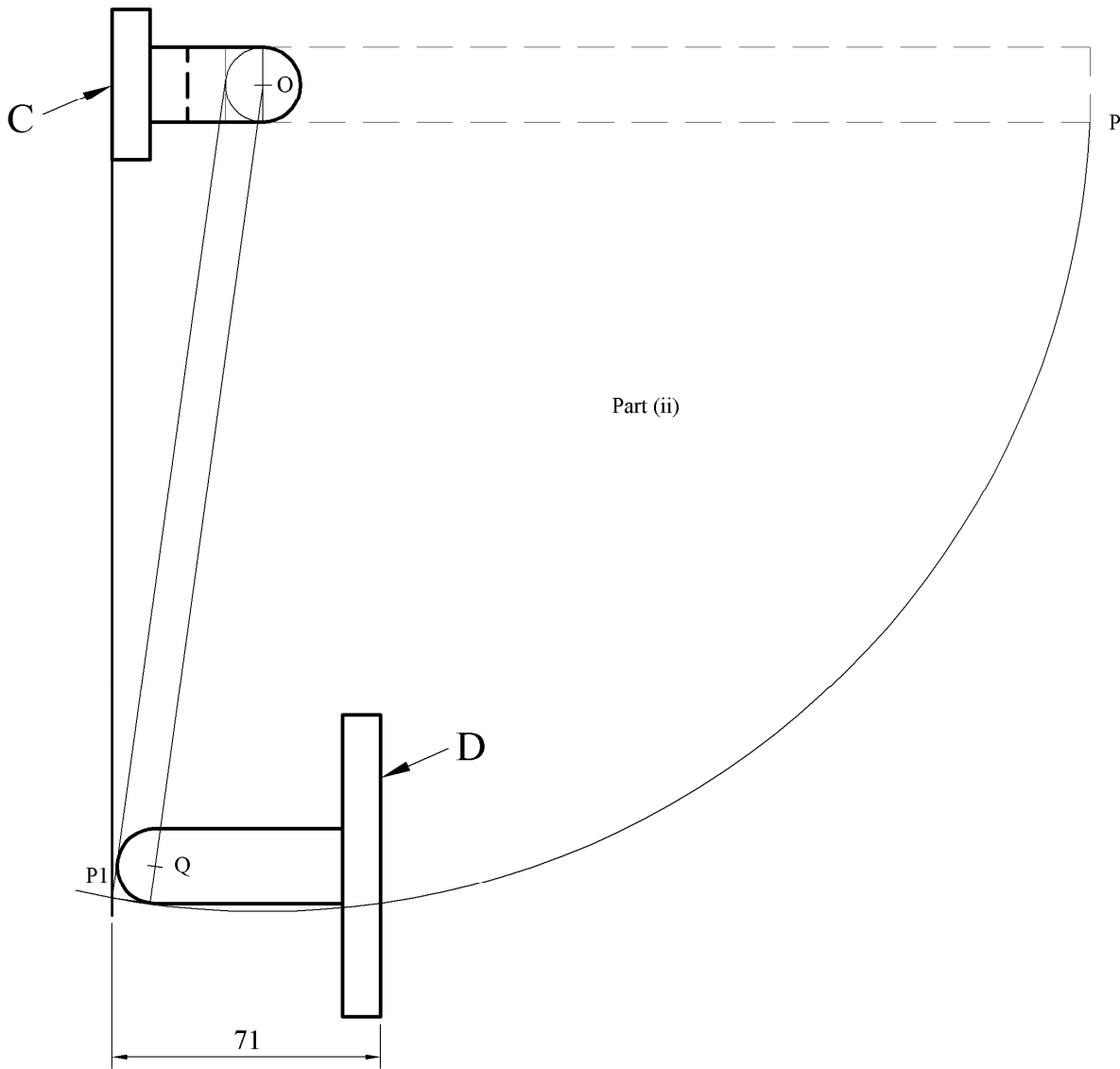
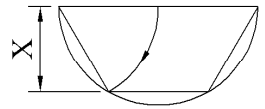
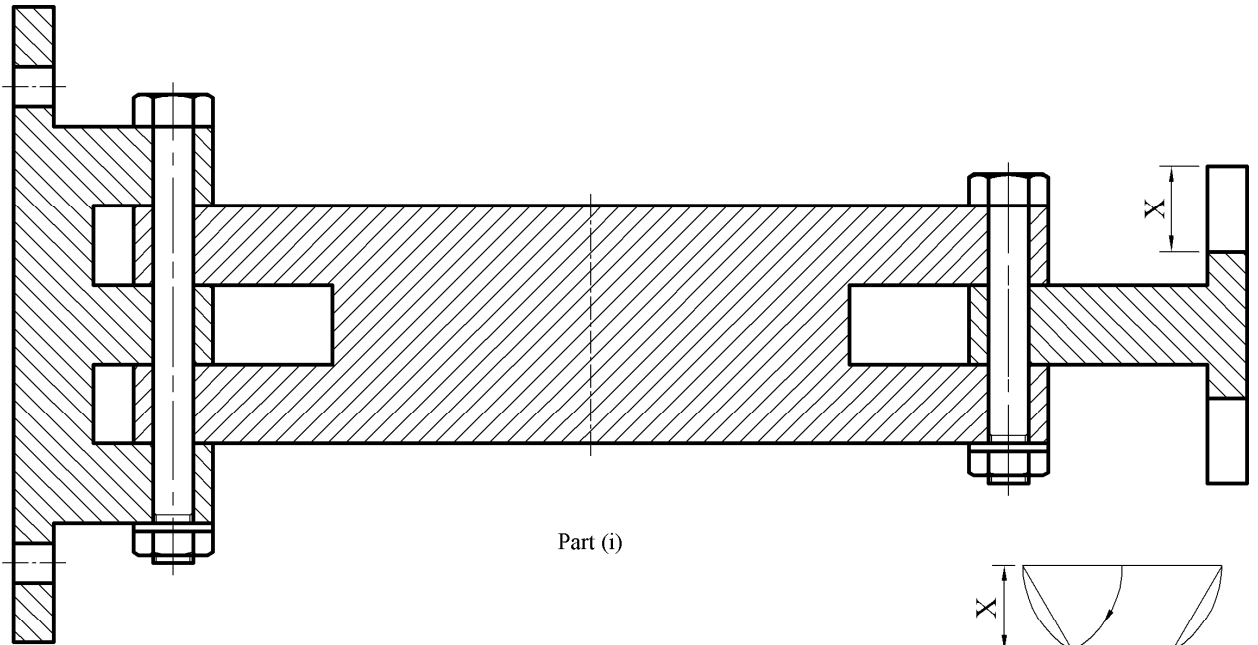

Design & Communication Graphics – Ord. Level	
	Marking Scheme
	Question C-5
	Scale: n/a June 2009



Design and Communication Graphics

Student Assignment - Ordinary Level

Assessment Sheet

Candidate Exam No.

Part (A) – 110 Marks		
Output	Marking criteria	Marks
1	Design Research - Exploration of main design features using primary & secondary research; Selection of appropriate graphics; Effective layout and presentation of information combining images, sketches & annotations	
	a) All relevant criteria considered - excellent presentation	13 - 15
	b) Most relevant criteria considered - very good presentation	10 - 12
	c) Some relevant criteria considered - good presentation	7 - 9
	d) Limited criteria considered - fair presentation	4 - 6
	e) At least one criterion considered - poor presentation	0 - 3
2	Design Feature Comparison - Selection of two appropriate images; Main dimensions inserted; Comparison of main design features; Contrasting of main design features; Effective layout and presentation of information combining images, sketches & annotations	
	a) All relevant criteria considered - excellent presentation	13 - 15
	b) Most relevant criteria considered - very good presentation	10 - 12
	c) Some relevant criteria considered - good presentation	7 - 9
	d) Limited criteria considered - fair presentation	4 - 6
	e) At least one criterion considered - poor presentation	0 - 3
3	Freehand Graphical Representation – Proportion; Form/Volume; Use of Tone/Line for effective rendering; Detailed treatment of main design features; Presentation	
	a) All relevant criteria considered - excellent presentation	17 - 20
	b) Most relevant criteria considered - very good presentation	13 - 16
	c) Some relevant criteria considered - good presentation	9 - 12
	d) Limited criteria considered - fair presentation	5 - 8
	e) At least one criterion considered - poor presentation	0 - 4
4	SolidWorks Parts, Assembly and eDrawing	
	• Minimum of 3 parts	6
	• Part models - Proficiency in Parametric CAD; Selection of most appropriate profile; Sketches fully defined; All features renamed; Appropriate type of extrusions used	12
	• Assembly - Accuracy of parts to facilitate correct assembly, Correct mating of parts, Application of materials/textures/colour	6
	• eDrawing of CAD model	6
5	Hardcopy outputs from SolidWorks - Detailed orthographic views of the Assembly; Rendered pictorial view of the Assembly; Exploded view of the CAD model; Inclusion of main dimensions; Presentation	
	a) All relevant criteria considered - excellent presentation	17 - 20
	b) Most relevant criteria considered - very good presentation	13 - 16
	c) Some relevant criteria considered - good presentation	9 - 12
	d) Limited criteria considered - fair presentation	5 - 8
	e) At least one criterion considered - poor presentation	0 - 4
6	Photorealistic Image	
	Produce a photorealistic computer generated image of the artefact	10
Part (B) – 50 Marks		
7	Graphical exploration of design solutions - Exploration of theme/ possible solution(s); Justification of chosen solution(s); Use of appropriate images/graphics; Effective layout and presentation of information combining images, sketches & annotations	
	a) All relevant criteria considered - excellent presentation	17 - 20
	b) Most relevant criteria considered - very good presentation	13 - 16
	c) Some relevant criteria considered - good presentation	9 - 12
	d) Limited criteria considered - fair presentation	5 - 8
	e) At least one criterion considered - poor presentation	0 - 4
8	Presentation of Modification/Concept Design – Proportion, Form/Volume, Use of Tone/Line for effective rendering, Detailed treatment of modified/concept design features; Presentation	
	a) All relevant criteria considered - excellent presentation	9 - 10
	b) Most relevant criteria considered - very good presentation	7 - 8
	c) Some relevant criteria considered - good presentation	5 - 6
	d) Limited criteria considered - fair presentation	3 - 4
	e) At least one criterion considered - poor presentation	0 - 2
9	Hardcopy outputs from SolidWorks - Detailed orthographic views of the proposed solution; Rendered pictorial view of the CAD model, Inclusion of main dimensions; Presentation	
	a) All relevant criteria considered - excellent presentation	17 - 20
	b) Most relevant criteria considered - very good presentation	13 - 16
	c) Some relevant criteria considered - good presentation	9 - 12
	d) Limited criteria considered - fair presentation	5 - 8
	e) At least one criterion considered - poor presentation	0 - 4
Total		

