



*Leaving Certificate Examination, 2011*

***Design & Communication Graphics***  
***Higher Level***

***Sections B and C (180 marks)***

**Friday, 17 June**

**Afternoon, 2:00 - 5:00**

**This examination is divided into three sections:**

- SECTION A (Core - Short Questions)  
SECTION B (Core - Long Questions)  
SECTION C (Applied Graphics - Long Questions)

- SECTION A**
- Four questions are presented.
  - Answer **any three** on the accompanying A3 examination paper.
  - All questions in Section A carry **20 marks** each.

- SECTION B**
- Three questions are presented.
  - Answer **any two** on drawing paper.
  - All questions in Section B carry **45 marks** each.

- SECTION C**
- Five questions are presented.
  - Answer **any two** (i.e. the options you have studied) on drawing paper.
  - All questions in Section C carry **45 marks** each.

**General Instructions:**

- *Construction lines must be shown on all solutions.*
- *Write the question number distinctly on the answer paper in Sections B and C.*
- *Work on one side of the drawing paper only.*
- *All dimensions are given in metres or millimetres.*
- *Write your Examination number in the box provided on section A and on all other sheets used.*

## SECTION B - Core

Answer **Any Two** questions from this section on drawing paper

**B-1.** A 3D graphic of a trophy for an archery competition is shown on the right. The trophy consists of a number of intersecting solids.

Fig. B-1 below shows the incomplete projections of two of the solids which penetrate each other.

- (a) In the diagram an irregular based pyramid rests on the horizontal plane. Draw the plan and elevation of this pyramid.
- (b) An equilateral triangular prism, of 40mm side, penetrates the pyramid as shown. Draw the outline plan and elevation of this triangular prism.
- (c) Complete the drawing, showing all lines of interpenetration.

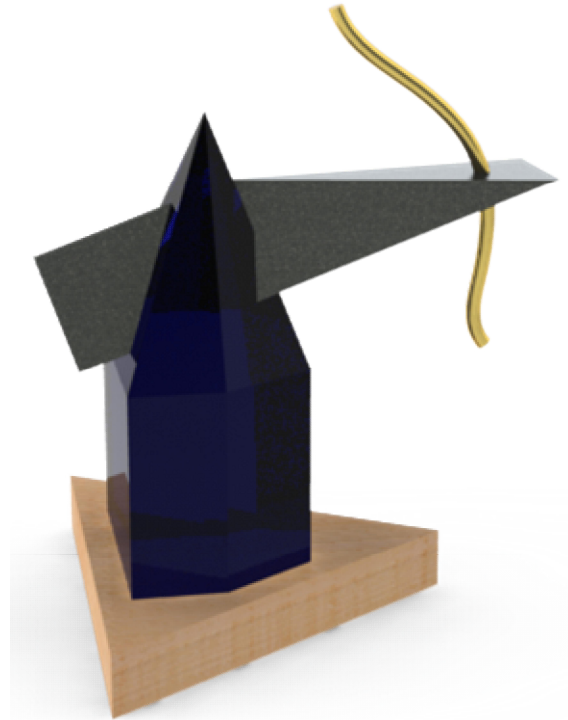

Scale 1:1

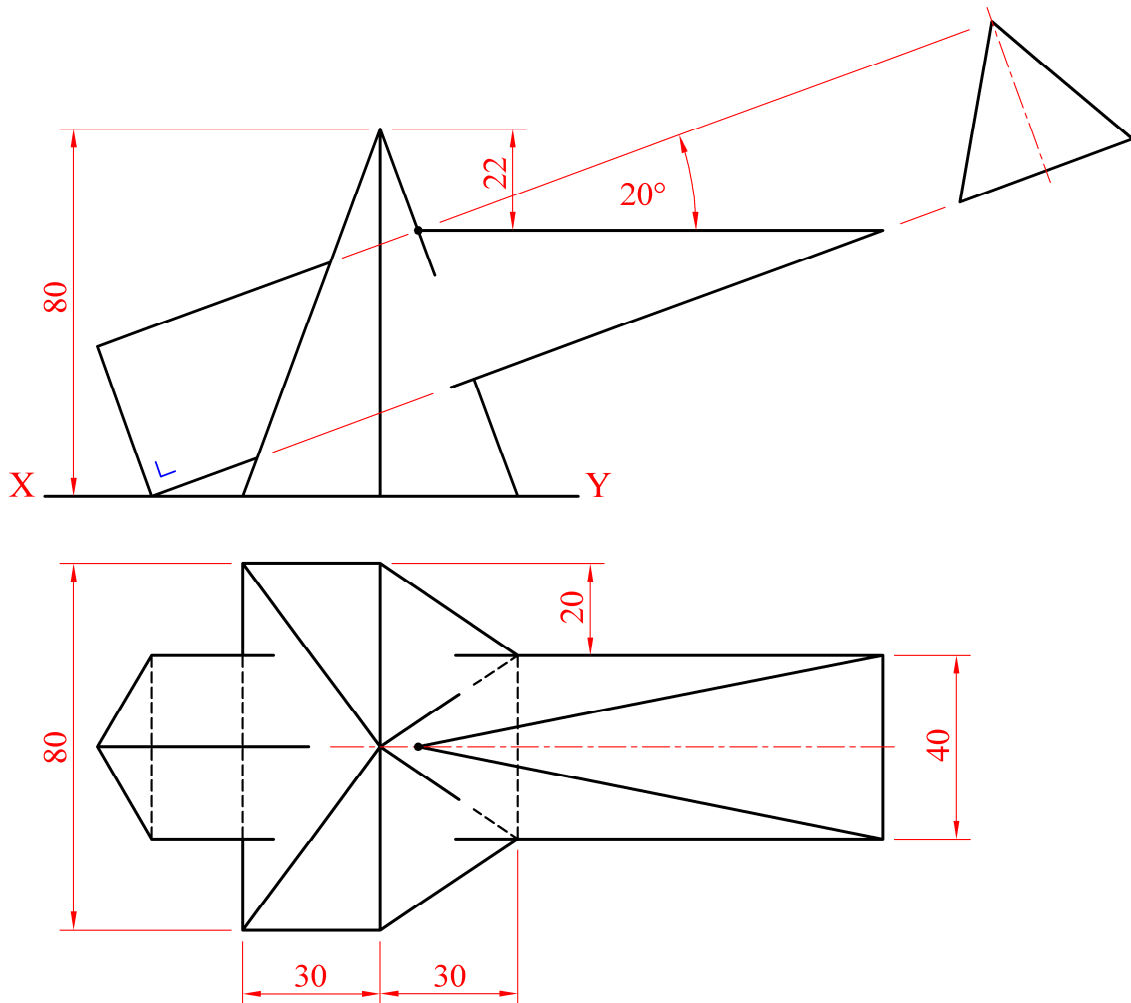
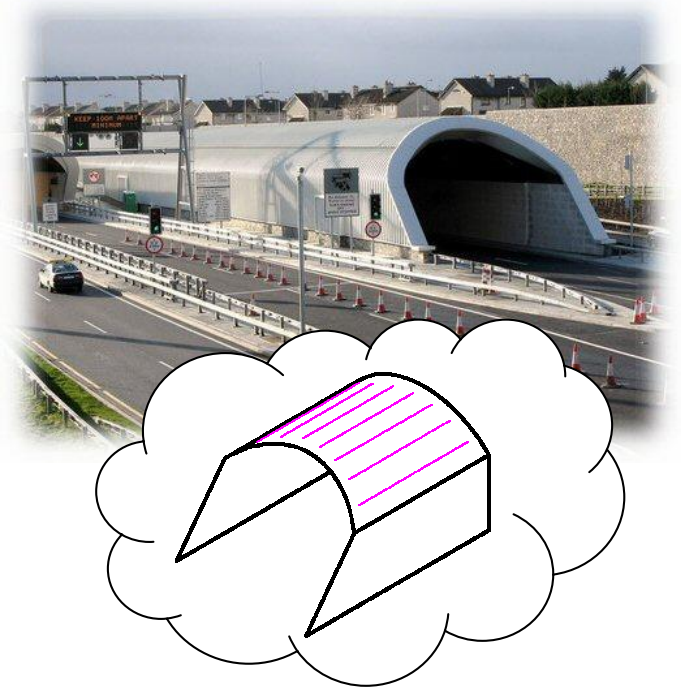

**Fig. B-1**

**B-2.** The 3D graphic on the right shows an exit from Dublin's Port Tunnel. The outline of the exit is also shown, as a line diagram, in the thought bubble.

Fig. B-2 below shows an incomplete dimetric projection of the tunnel exit (using the axonometric axes method).

The elevation and end view are also shown in their required positions.



- (a) Draw the axonometric axes **X**, **Y** and **Z** and the isosceles triangle **abc**.
- (b) Draw the elevation and end view orientated as shown.
- (c) Draw the completed axonometric projection.
- (d) In the pictorial projection, identify the traces of the simply inclined plane that contains the sloped exit.

**Scale 1:100**

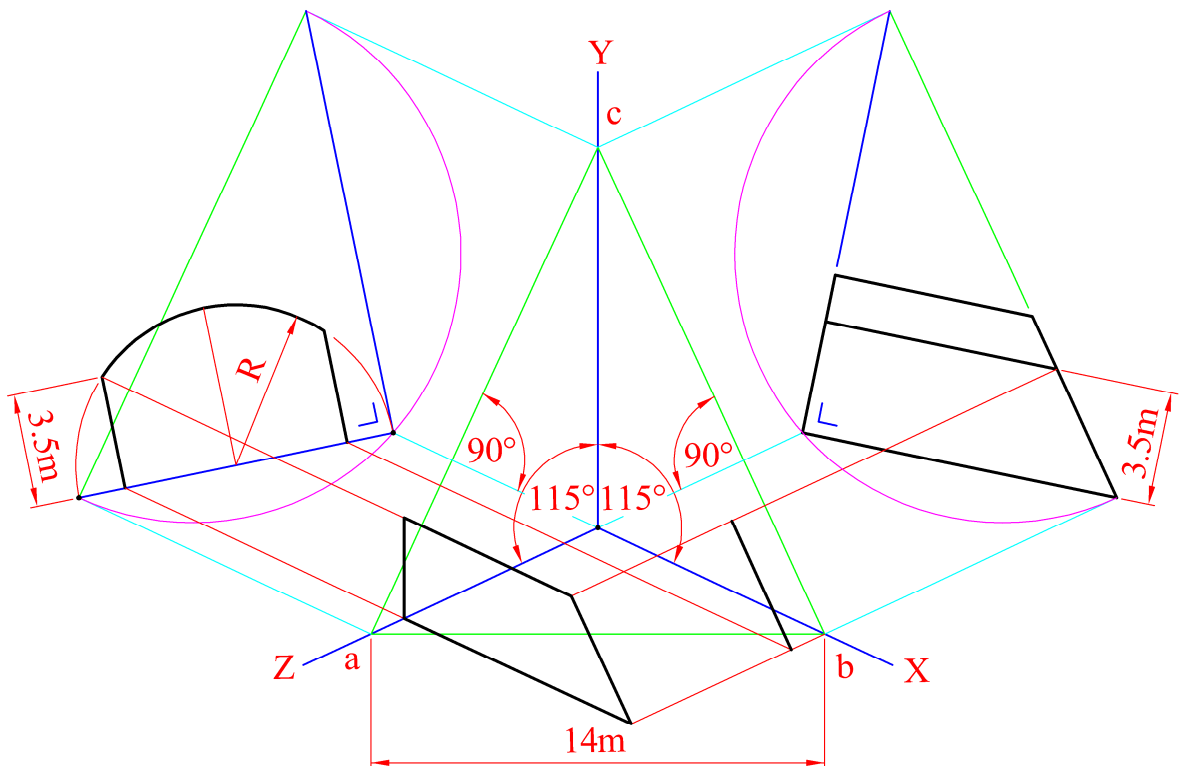

**Fig. B-2**

**B-3.** The 3D graphic on the right shows some make-up items. The balloon diagram shows an enlarged view of the top of the Lipstick, which is in the form of a right cylinder that has been shaped as shown.

Fig. B-3 below shows the plan and elevation of the top portion of the lipstick.

- (a) Draw the given elevation and plan and project an end view in the direction of arrow A.
- (b) Draw the true shape of the elliptical cut surface S.
- (c) Draw the elevation of the focal sphere (as indicated in the 3D graphic on the right below) and, on your drawing, establish the position of the focal point and directrix for the elliptical cut surface S.



**Scale 5:1 (Enlarged scale)**

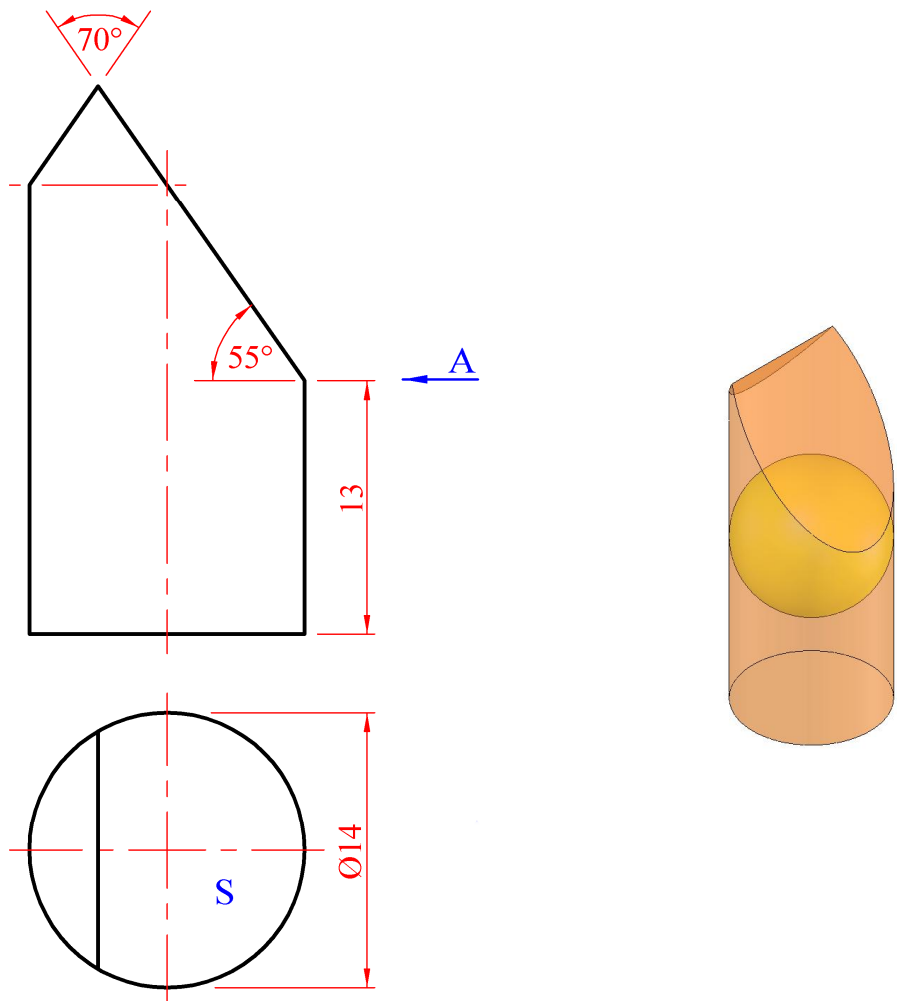

**Fig. B-3**

## SECTION C - Applied Graphics

Answer **Any Two** questions (i.e. the options you have studied)  
from this section on drawing paper.

### Geologic Geometry

**C-1. (a)** The accompanying map, located on the back page of Section A, shows ground contours at five metre vertical intervals.

**ABCD** is the centreline of a proposed roadway. **O** is the centre of the circular curve.

The roadway has the following specification:

- (i) the section of the roadway between **A** and **B** is level at an altitude of 70m
- (ii) the section between **B** and **C** is also level at an altitude of 70m and is curved as shown
- (iii) the section from **C** to **D** has a gradient of 1 in 15 falling.

Using side slopes of 1 in 1.5 for the cuttings and 1 in 2 for the embankments, complete the earthworks necessary to accommodate the roadway on its northern side.

*Note: The earthworks on the southern side of the roadway have already been completed.*

**(b)** On the map, **E**, **F** and **G** are outcrop points on the top surface of a stratum of ore.

- (i) Complete the given construction to determine the strike line for the stratum.
- (ii) Determine the dip of the stratum.

**Scale 1:1000**

# Structural Forms

**C-2.** The 3D graphic on the right shows an office chair with a support cushion attached. The cushion, which is designed to allow air movement, is in the form of a hyperbolic paraboloid.



Fig. C-2 below shows the elevation and end view of the support cushion. The outline shape is formed by extending the hyperbolic paraboloid surface **ABCD**.

(a) The perimeter, in elevation, is a portion of a semi-ellipse, having a major axis of 720mm and a minor axis of 256mm, as shown. Draw the given elevation.

(b) Using six elements in each direction, project the given end view, showing all construction lines clearly.

*Additional elements, where required, should be used to establish accurate curves.*

(c) Determine the curvature of the surface along the Section S-S.

**Scale 1:2**

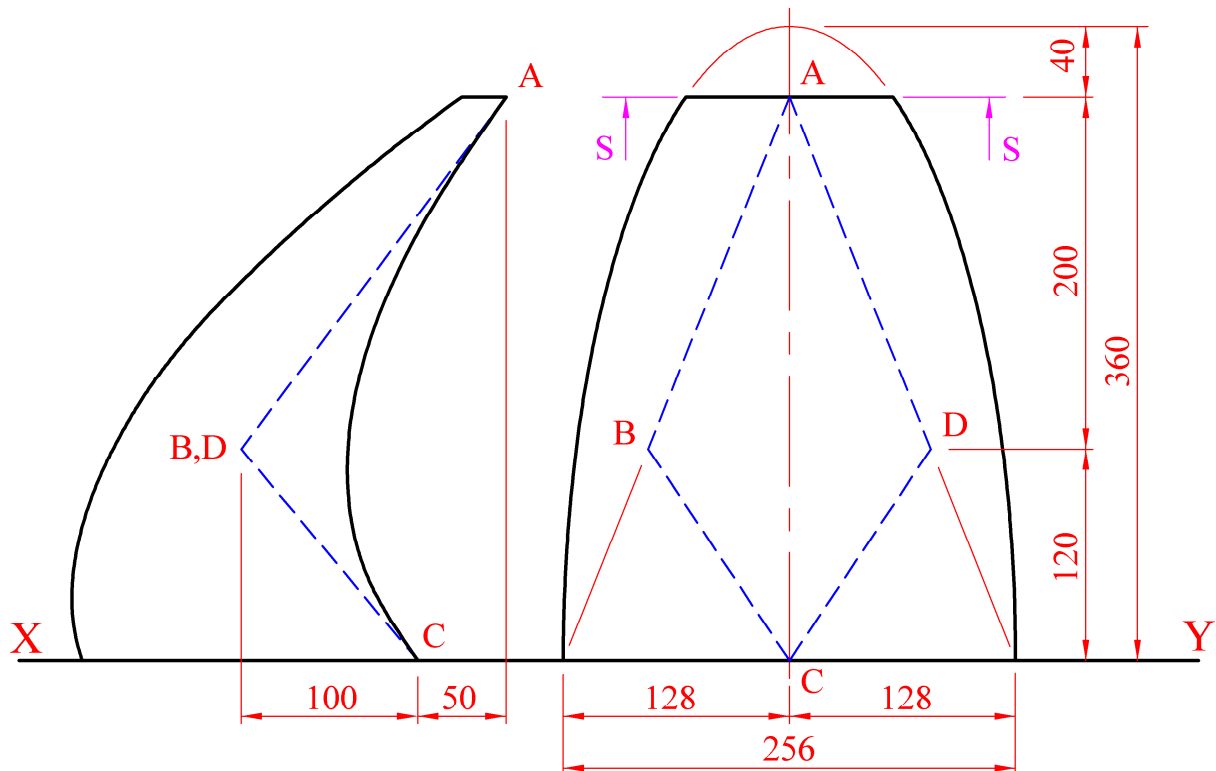

**Fig. C-2**

# Surface Geometry

**C-3.** The 3D graphic on the right shows Dublin's new Grand Canal Theatre. The front of the modern structure features several intersecting sloping glass surfaces.



Fig. C-3 below shows the outline plan and elevation of a portion of a similar glass structure.

- (a) Surfaces **A** and **B** have a pitch of  $50^\circ$ . Draw the plan and elevation of these two surfaces and determine the dihedral angle between them.
- (b) The opposite edges, '**pq**' and '**rs**', of the surface **D** are parallel. Draw the plan and elevation of surfaces **C** and **D**.
- (c) The dihedral angle between surfaces **D** and **E** is  $125^\circ$ . Complete the projections of surface **E**.

**Scale 1:100**

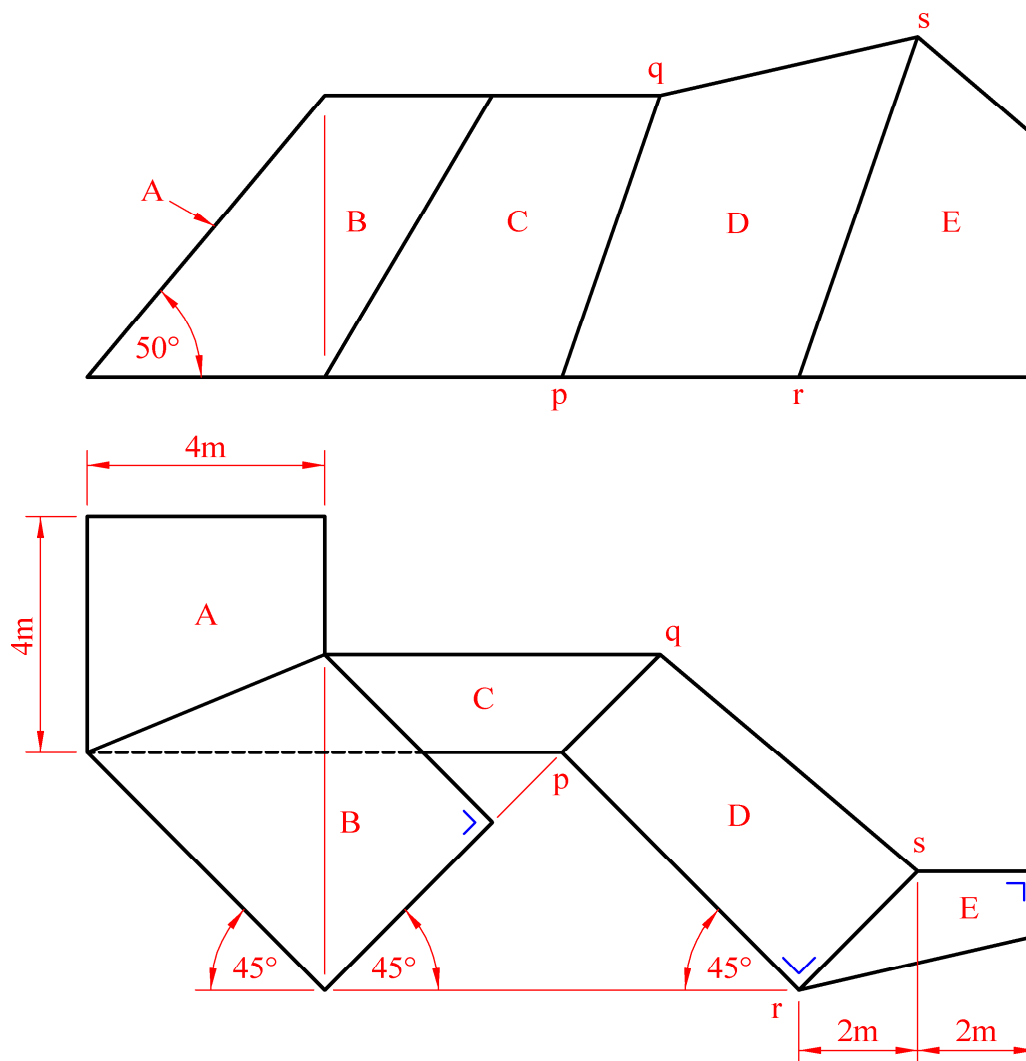

**Fig. C-3**



# Dynamic Mechanisms

**C-4. (a)** The 3D graphic on the right shows a camshaft and roller follower from a lawnmower.

Details of a similar cam and follower are given below.

The camshaft diameter is 24mm and the diameter of the in-line roller follower is 20mm. The nearest approach of the centre of the roller follower to the cam centre is 52mm.

The cam rotates in a clockwise direction.

Draw the displacement diagram and the cam profile given the following data:

- $0^\circ$  to  $90^\circ$  Rise 55mm with uniform velocity
- $90^\circ$  to  $180^\circ$  Dwell
- $180^\circ$  to  $360^\circ$  Fall 55mm with Simple Harmonic Motion.

**Scale 1:1**



**(b)** Logs, as shown in the graphic, were often used as rollers to move blocks of stone when building the Egyptian pyramids.

Fig. C-4 below shows a block **B** resting on three rollers.

- (i) Draw the rectangular block **B** and circular roller **L**, positioned on the ground as shown.
- (ii) The three rollers roll clockwise along the ground until point **P** on roller **L** touches the ground. Draw the locus of **P** for this movement.

*Note: It is not necessary to draw the other two rollers.*

- (iii) Show the block **B** in its final position after this rolling.

**Scale 1:10**

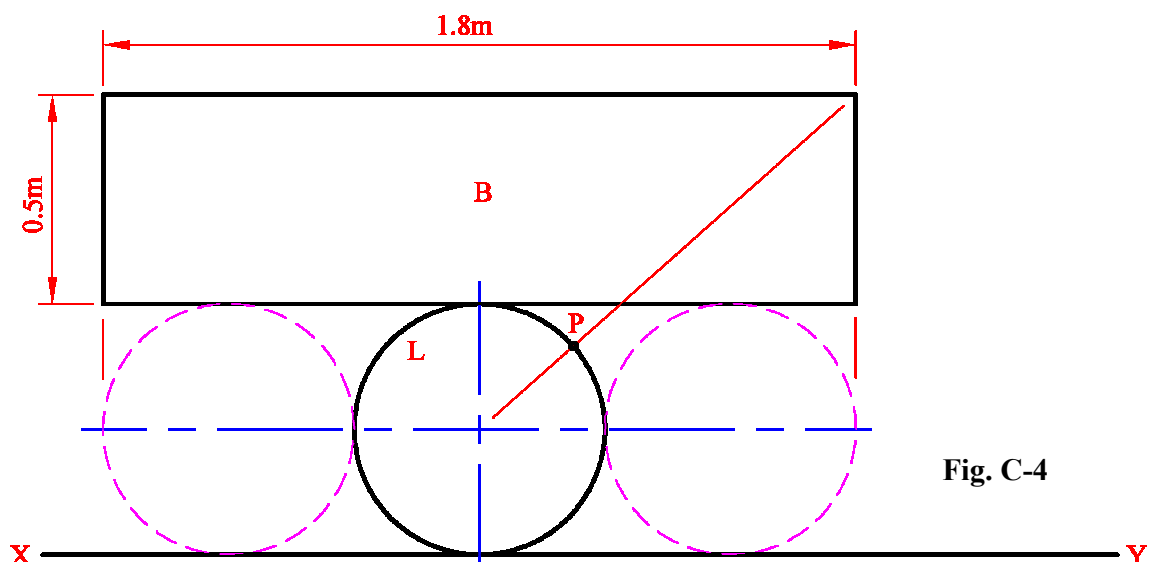

**Fig. C-4**



# Assemblies

- C-5. (a)** Details of a disassembled *Bird Feeder* are shown in Fig. C-5. The parts list is given below and a 3D Graphic of the individual parts is also shown. Draw a full size sectional elevation on A-A, showing the parts fully assembled with the lid closed. (All fillets are 6mm, chamfers 1x45° and any omitted dimensions may be estimated).
- (b)** Determine and indicate in degrees on your drawing the angle of rotation of the lid in moving from the fully closed to the fully open position.

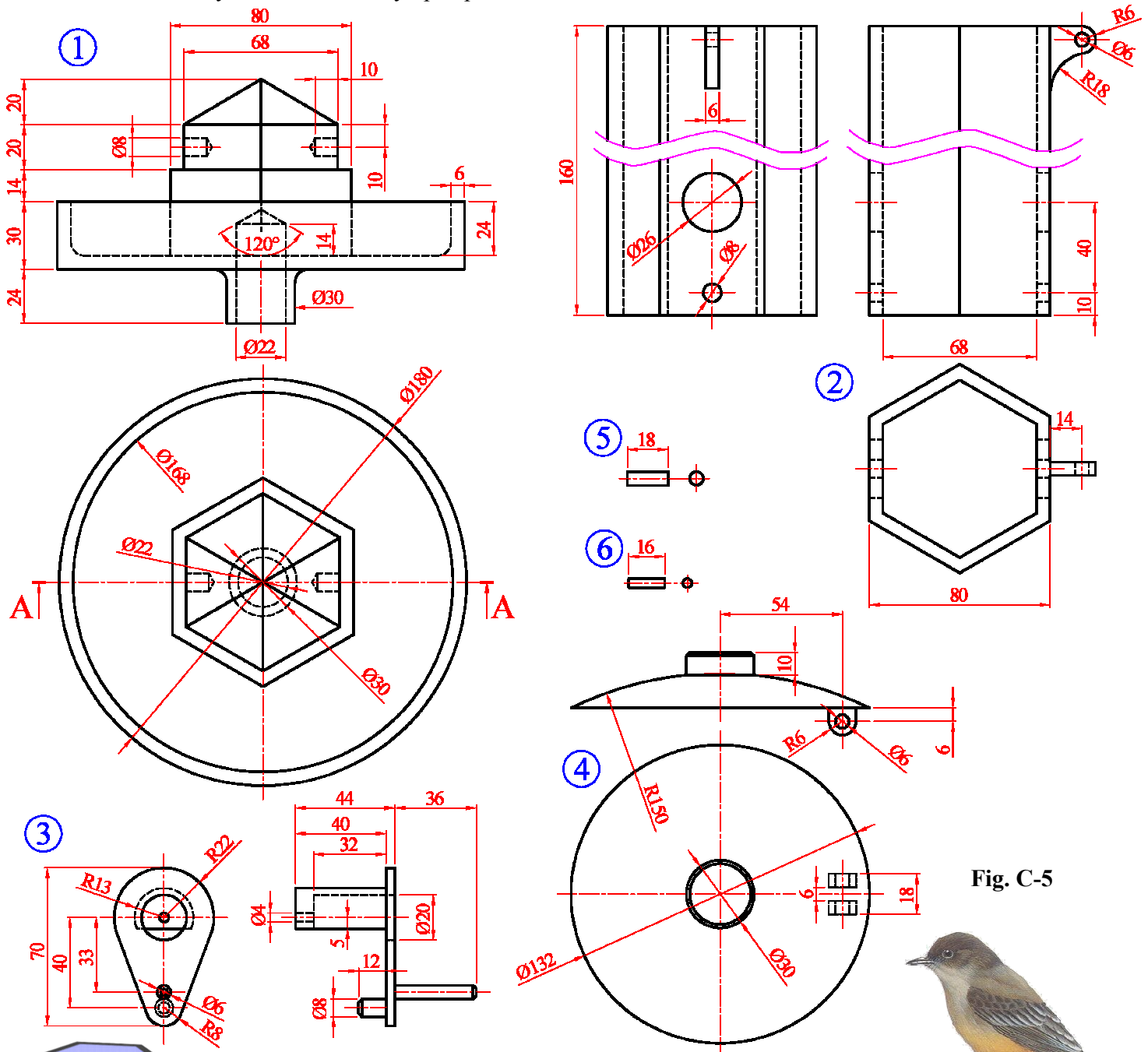
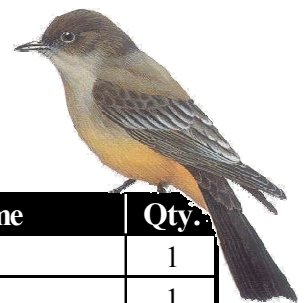

Fig. C-5



Part	Name	Qty.
1	Base	1
2	Seed Holder	1
3	Perch	2
4	Lid	1
5	Ø6mm Hinge Pin	1
6	Ø4mm Connecting Pin	1



**BLANK PAGE**

**BLANK PAGE**

**BLANK PAGE**