



Coimisiún na Scrúduithe Stáit
State Examinations Commission

M. 34

LEAVING CERTIFICATE EXAMINATION, 2005

CHEMISTRY - HIGHER LEVEL

TUESDAY, 21 JUNE – AFTERNOON 2.00 TO 5.00

400 MARKS

Answer **eight** questions in all

These **must** include at least **two** questions from **Section A**

All questions carry equal marks (50)

Information

Relative atomic masses: H = 1, C = 12, O = 16, Na = 23, Mg = 24, Cl = 35.5, Cr = 52, Cu = 63.5

Molar volume at room temperature and pressure = 24.0 litres

Avogadro constant = $6 \times 10^{23} \text{ mol}^{-1}$

Universal gas constant, $R = 8.3 \text{ J K}^{-1} \text{ mol}^{-1}$

Section A

Answer at least two questions from this section [see page 1 for full instructions].

1. In an experiment to measure the concentration of dissolved oxygen in a river water sample, a bottle of water was filled from the river and it was analysed immediately. The experiment was carried out as follows:

A few cm^3 each of concentrated manganese(II) sulfate (MnSO_4) solution and alkaline potassium iodide (KOH/KI) solution were added to the water in the bottle. The stopper was carefully replaced on the bottle and the bottle was shaken to ensure mixing of the reagents with the water. A brownish precipitate was produced. The stopper was removed from the bottle and a few cm^3 of concentrated sulfuric acid (H_2SO_4) were added carefully down the inside of the neck of the bottle using a dropper. The precipitate dissolved and a golden-brown solution was produced. The concentration of iodine (I_2) in this solution was found by titrating it in 50 cm^3 portions against a standard (0.01 M) sodium thiosulfate ($\text{Na}_2\text{S}_2\text{O}_3$) solution.

- (a) Why was it necessary to analyse the sample of river water *immediately*? (5)
- (b) In making the additions to the sample, why should the solutions used be *concentrated*? (6)
- (c) Describe how the additions of the concentrated solution of manganese(II) sulfate (MnSO_4) and alkaline potassium iodide (KOH/KI) to the bottle of river water should be carried out. What essential precaution should be taken when replacing the stopper of the bottle after these additions are made? (9)
- (d) Describe clearly the procedure for using a pipette to measure exactly 50 cm^3 portions of the iodine (I_2) solution into the titration flask. (9)
- (e) What indicator is used in this titration? State when the indicator should be added to the titration flask and describe the colour change observed at the end point. (9)
- (f) The titration reaction is described by the following equation.

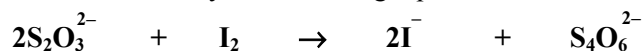

- Calculate the concentration of the iodine solution in moles per litre given that 6.0 cm^3 of the 0.01 M sodium thiosulfate ($\text{Na}_2\text{S}_2\text{O}_3$) solution were required in the titration for complete reaction with 50 cm^3 portions of the iodine solution. (6)
- (g) For every 1 mole of oxygen gas (O_2) in the water sample 2 moles of iodine (I_2) are liberated in this experiment. Hence calculate the concentration of dissolved oxygen in the water sample in p.p.m. (6)

2. A group of students prepared ethanal (CH_3CHO) by slowly adding an aqueous solution of ethanol ($\text{C}_2\text{H}_5\text{OH}$) and sodium dichromate(VI) ($\text{Na}_2\text{Cr}_2\text{O}_7 \cdot 2\text{H}_2\text{O}$) to a hot aqueous solution of sulfuric acid (H_2SO_4). The apparatus drawn below was used. The reaction is described by the following equation.

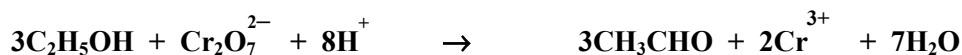

(a) Why was the receiving vessel cooled in ice-water? (5)

(b) State **two** features of the preparation that are necessary to maximise the yield of ethanal and, for each feature stated, explain why it is necessary. (12)

(c) Describe and account for the colour change which is observed during the addition of the ethanol and sodium dichromate(VI) solution to the hot acid. (9)

(d) Describe how you would carry out Fehling's test on a sample of ethanal. What observation would you expect to make in this test? (12)

(e) Assuming that all of the features needed to maximise the yield of ethanal were present, what mass of ethanal would be produced in the preparation if the students used 8.94 g of sodium dichromate(VI) ($\text{Na}_2\text{Cr}_2\text{O}_7 \cdot 2\text{H}_2\text{O}$), and a 75% yield was obtained? (12)

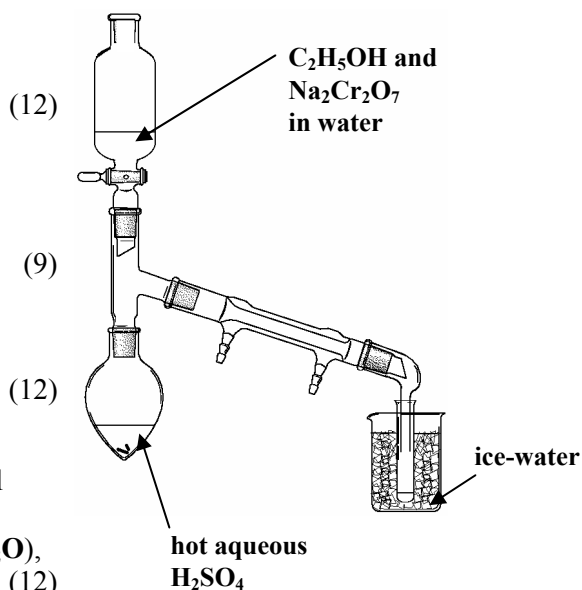

3. Hydrogen peroxide decomposes rapidly in the presence of a manganese(IV) oxide (MnO_2) catalyst.

(a) Write a balanced equation for the decomposition of hydrogen peroxide. (5)

(b) Draw a labelled diagram of an apparatus a student could assemble to measure the rate of decomposition of hydrogen peroxide in the presence of a manganese(IV) oxide (MnO_2) catalyst. Indicate clearly how the reaction could be started at a time known exactly, and how the gas produced is collected and its volume measured. (12)

(c) A student has a choice of using the same mass of finely powdered manganese(IV) oxide or coarsely powdered (granulated) manganese(IV) oxide. Which of these would you expect to have a greater average rate of reaction over the first minute of the reaction? Give a reason for your answer. (6)

A set of results obtained in an experiment to measure the rate of decomposition of hydrogen peroxide, in a solution of known volume and concentration, is given in the table.

Time/minutes	0	1	2	3	4	5	6	7	8
Volume of O_2/cm^3	0.0	13.5	23.4	30.5	35.4	38.3	39.6	40.0	40.0

(d) Plot a graph to illustrate the volume of oxygen produced *versus* time. (12)

(e) Use the graph to determine

(i) the volume of oxygen produced during the first 2.5 minutes and

(ii) the instantaneous rate of the reaction at 2.5 minutes. (9)

(f) What changes would you expect in the graph if the experiment were repeated using a solution of the same volume but exactly half the concentration of the original hydrogen peroxide solution? (6)

Section B

[See page 1 for instructions regarding the number of questions to be answered]

4. Answer **eight** of the following items (a), (b), (c), etc. (50)

- (a) Define *electronegativity*.
- (b) What are the possible shapes for molecules of general formula AB_2 ?
- (c) Name the series of coloured lines in the line emission spectrum of hydrogen corresponding to transitions of electrons from higher energy levels to the second ($n = 2$) energy level.
- (d) What contribution did Dobereiner make to the systematic arrangement of the elements?
- (e) Distinguish between an *atomic orbital* and a *sub-level*.
- (f) How could you confirm the presence of nitrate ions in an aqueous solution?
- (g) Name and draw the structure of an aromatic compound of molecular formula C_8H_{10} .
- (h) When 3.175 g of copper reacts with chlorine gas 6.725 g of copper chloride is formed. Find by calculation the empirical formula of the chloride.
- (i) Draw the structural formula of an organic compound of molecular formula C_3H_6 . Label clearly any tetrahedrally bonded carbon atom in the molecule.
- (j) Complete and balance the following equation:

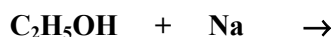

(k) Answer part **A** or **B**.

A Describe using chemical equations the chain reaction process whereby chlorine free radicals break down ozone in the stratosphere.

or

B How does a sacrificial anode protect a metal from corrosion?

5. (a) What are *isotopes*? (5)

Name the scientist pictured on the right who is credited with the discovery in 1896 that uranium salts emit radiation. (3)

Give an example of a radioactive isotope and state **one** common use made of this isotope. (9)

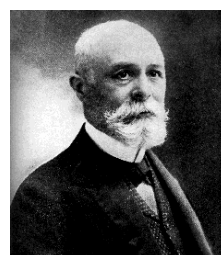

(b) Define *atomic radius (covalent radius)*. (6)

Describe and account for the trend in atomic radii (covalent radii) of the elements

(i) across the second period, (ii) down any group, of the periodic table. (15)

(c) Define *covalent bond*. (6)

Distinguish between a sigma (σ) and a pi (π) covalent bond. (6)

6. (a) The octane number of a fuel is described as *a measure of the tendency of the fuel to cause knocking*, or as *a measure of the tendency of the fuel to resist auto-ignition*. This number is found by comparing the combustion of the fuel with the combustion of a mixture of two reference hydrocarbons using the same standard engine.
- (i) Name **both** of the reference hydrocarbons present in the mixture used when measuring octane number by this comparison method. (8)
- (ii) State **two** structural features of a hydrocarbon molecule which contribute to it having a high octane number. (6)
- (iii) Lead compounds were used in the past to increase the octane number of fuels. Why are lead compounds unsuitable as additives for petrol used in modern cars? (3)
- (iv) Identify **one** additive *or* type of additive, other than a compound of lead, used to increase the octane number of fuels. (3)
- (b) There are **three** structural isomers of the hydrocarbon of formula C_5H_{12} . In the case of **each** of these isomers, draw the structure of the molecule and give its systematic IUPAC name. (18)
- (c) The combustion of liquid benzene is described by the following equation:

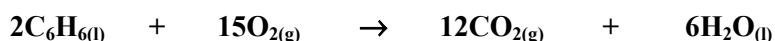

Given that the heats of formation of carbon dioxide gas, liquid water and liquid benzene are -394 , -286 and 49 kJ mol^{-1} respectively, calculate the heat of combustion of liquid benzene. (12)

7. Examine the reaction scheme and answer the questions which follow.

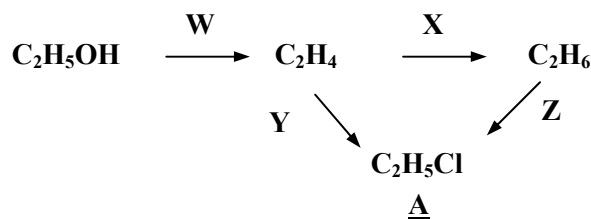

- (a) Name the compound labelled A. (5)
- (b) For each of the conversions **W**, **X**, **Y** and **Z**, classify it as an *addition*, an *elimination* or a *substitution* reaction. (12)
- (c) Describe with the aid of a labelled diagram how the conversion **W** may be carried out in a school laboratory and how a sample of the product may be collected. How would you test this product to show that it is unsaturated? (18)
- (d) The conversion labelled **Z** is known to occur by a *free radical* mechanism. State **three** clear pieces of experimental evidence which support this mechanism. (15)
-
8. (a) Define (i) *acid*, (ii) *base*, according to the Brønsted-Lowry theory. (8)
- (b) Identify **one** species acting as an acid, and also identify its conjugate base, in the following system. (6)
- $$H_2F^+ + Cl^- \rightleftharpoons HCl + HF$$
- (c) Calculate the pH of a 0.002 M solution of methanoic acid ($HCOOH$). The value of K_a for methanoic acid is 1.8×10^{-4} . (12)
- (d) What is meant by the *biochemical oxygen demand (BOD)* of a water sample? (6)
- (e) Describe clearly the processes involved in the primary and secondary stages of urban sewage treatment. What substances are removed by tertiary treatment of sewage? (18)

9. (a) State *Le Chatelier's principle*. (5)
- (b) A student is provided with glassware and other laboratory apparatus as well as the following chemicals: potassium dichromate(VI) ($\text{K}_2\text{Cr}_2\text{O}_7 \cdot 2\text{H}_2\text{O}$), hydrochloric acid ($\text{HCl}_{(\text{aq})}$), sodium hydroxide (NaOH), cobalt(II) chloride crystals ($\text{CoCl}_2 \cdot 6\text{H}_2\text{O}$) and deionised water (H_2O).

(i) Describe clearly how the student could use a selection of the chemicals listed above to establish a chemical equilibrium. Write a balanced equation for the equilibrium. (12)

(ii) Describe how the student could then demonstrate the effect of concentration on that chemical equilibrium. State the observations made during the demonstration. (9)

- (c) The value of K_c for the following equilibrium reaction is 4.0 at a temperature of 373 K.

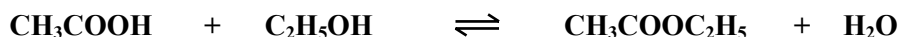

(i) Write the equilibrium constant (K_c) expression for this reaction. (6)

(ii) What mass of ethyl ethanoate ($\text{CH}_3\text{COOC}_2\text{H}_5$) would be present in the equilibrium mixture if 15 g of ethanoic acid and 11.5 g of ethanol were mixed and equilibrium was established at this temperature? (18)

10. Answer any **two** of the parts (a), (b) and (c). (2 × 25)

(a) An indigestion tablet contains a mass of 0.30 g of magnesium hydroxide [$\text{Mg}(\text{OH})_2$] as its only basic ingredient. The balanced chemical equation for the reaction between magnesium hydroxide and hydrochloric acid ($\text{HCl}_{(\text{aq})}$), the acid produced in the stomach, is as follows:

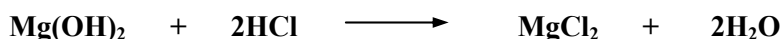

(i) Calculate the volume of 1.0 M HCl neutralised by two of these indigestion tablets. Give your answer correct to the nearest cm^3 . (8)

(ii) What mass of salt is formed in this neutralisation? (5)

(iii) How many magnesium ions are present in this amount of the salt? (6)

(iv) Another indigestion remedy consists of a suspension of magnesium hydroxide [$\text{Mg}(\text{OH})_2$] in water and is marked 6% (w/v). What volume of this second indigestion remedy would have the same neutralising effect on stomach acid as two of the indigestion tablets mentioned earlier? (6)

(b) The minimum energy required to completely remove the most loosely bound electron from a mole of gaseous atoms in their ground state defines an important property of every element.

(i) Identify the energy quantity defined above. State the unit used to measure this quantity. (7)

(ii) Using X to represent an element, express the definition above in the form of a balanced chemical equation. (6)

(iii) Would it take more or less energy to remove the most loosely bound electron from an atom if that electron were not in its ground state? Explain. (6)

(iv) An element has a low first ionisation energy value and a low electronegativity value. What does this information tell you about how reactive the element is likely to be, and what is likely to happen to the atoms of the element when they react? (6)

(c) State the principle on which all chromatographic separation techniques are based. (10)

Describe with the aid of clearly labelled diagrams how you could carry out an experiment to separate a mixture of dyes (or indicators) using paper, thin-layer or column chromatography. (15)

11. Answer any **two** of the parts (a), (b) and (c).

(2 × 25)

- (a) (i) Define *oxidation* in terms of change in oxidation number. (4)
- (ii) What is observed when chlorine gas is bubbled into an aqueous solution of sodium bromide? (9)
- Explain your answer in terms of oxidation and reduction.
- (iii) A solution of acidified water (dilute sulfuric acid) is electrolysed by passing an electric current through it using inert electrodes. (12)
- At which electrode **A** or **B** does oxidation occur?
- Which species is oxidised?
- Write a balanced half equation for the oxidation reaction.

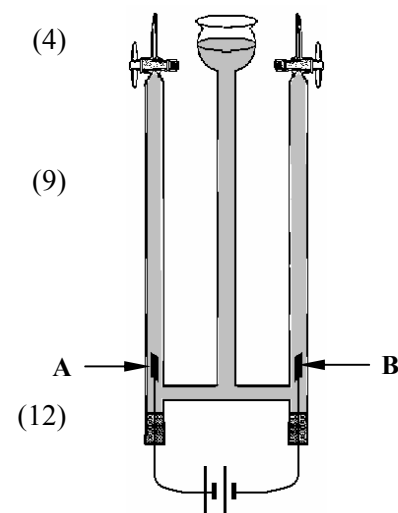

- (b) (i) Define *a mole of a substance*. (7)
- (ii) State *Avogadro's law*. (6)
- (iii) A foil balloon has a capacity of 10 litres. How many atoms of helium occupy this balloon when it is filled with a 10% (v/v) mixture of helium in air at room temperature and pressure? (12)

(c) Answer either part **A** or part **B**.

A

- (i) What is meant by the term *addition polymerisation*? (7)
- (ii) Name the Du Pont chemist pictured on the right who discovered poly(tetrafluoroethene), PTFE. (3)
- (iii) Describe using an equation how poly(tetrafluoroethene) is produced from its monomers. (9)
- (iv) Give **two** common uses of PTFE. (6)



Discoverer of PTFE

OR

B

- (i) Account for the inert nature of nitrogen gas. (7)
- (ii) What is meant by *nitrogen fixation*? (9)
- State **two** ways by which nitrogen is fixed in nature. (9)
- (iii) The concentration of NO_2 in the atmosphere has increased in the past fifty years. Describe with the aid of chemical equations how an increase in the number of cars has contributed to this change. (9)

Blank Page