



**Coimisiún na Scrúduithe Stáit**  
**State Examinations Commission**

***Leaving Certificate Applied, 2012***

**Vocational Specialism - Technology**  
**(240 Marks)**

*Wednesday 13th June, Afternoon 2:00 to 4:00*

*General Directions:*

1. Write your examination number in this box:

--

2. There are two sections in this paper.  
 Section 1– Answer **all three** questions. - 90 marks

**Q1. - Short answer questions**  
**Q2. - Graphical Communication**  
**Q3. - Health and safety**

Section 2– Five questions, answer **any three** - 150 marks

**Q1. - Introducing Technology**  
**Q2. - Design and Manufacture**  
**Q3. - Water Technology**  
**Q4. - Electrical Understanding and Basic Electronics**  
**Q5. - Tools and Equipment**

3. Write your answers in the spaces provided and include sketches (in pencil) where appropriate.

<b>Centre Stamp</b>
---------------------

1.	Total of end of page totals	
2.	Aggregate total of all disallowed question(s)	
3.	Total mark awarded (1 minus 2)	
4.	Bonus mark for answering through Irish (if applicable)	
5.	Total mark awarded if Irish Bonus (3 plus 4)	
	<u>Note:</u> The mark in row 3 (or row 5 if Irish bonus is awarded) must equal the mark in the Total mark box on the script.	

Section	No.	Mark
Section 1	<b>1</b>	
	<b>2</b>	
	<b>3</b>	
Section 2	<b>1</b>	
	<b>2</b>	
	<b>3</b>	
	<b>4</b>	
	<b>5</b>	
Total		

# Question 1

## Compulsory

(40 marks)

1. Answer **any Ten** of the following fifteen short questions.

- (a) The graphic shows a plastic cutlery tray made from a thermo-plastic. Explain the term “thermo-plastic”.

Thermo-plastic \_\_\_\_\_  
\_\_\_\_\_  
\_\_\_\_\_  
\_\_\_\_\_



Cutlery tray

- (b) The compound gear train shown is made from metal. Suggest a suitable metal and give a valid reason for your choice.



Suitable metal \_\_\_\_\_

Reason for using this metal \_\_\_\_\_

- (c) Car manufacturers make extensive use of robots. Suggest **two** reasons for this.

1 \_\_\_\_\_

2 \_\_\_\_\_



Robotics in car manufacture

- (d) The picture shows a hand operated device for crushing aluminium cans. Three positions A, B, and C are indicated on the main lever. B represents the “Load” position. What do A and C represent?

<b>A</b>	
<b>B</b>	<b>Load</b>
<b>C</b>	

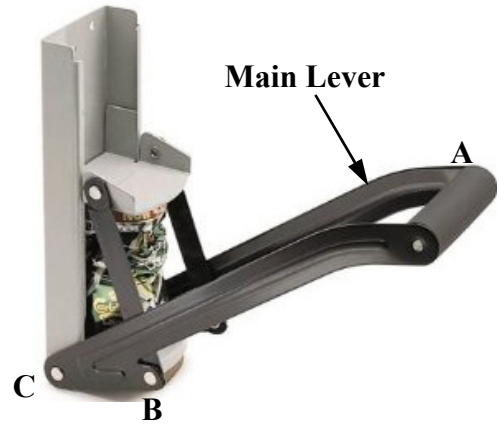

- (e) Suggest **two** examples of how materials from unwanted products may be recycled.

1 \_\_\_\_\_  
 \_\_\_\_\_

2 \_\_\_\_\_  
 \_\_\_\_\_



Recycling Logo

- (f) Convert **each** of the following dimensions into millimetres (mm).

Dimension	10.4cm	1.2m	0.6cm	10.5m
Millimetres				

- (g) The solid model of the machine part shown is an example of:

- Orthographic Projection
- Isometric Projection
- Perspective Projection
- Oblique Projection

**(Circle the correct answer)**

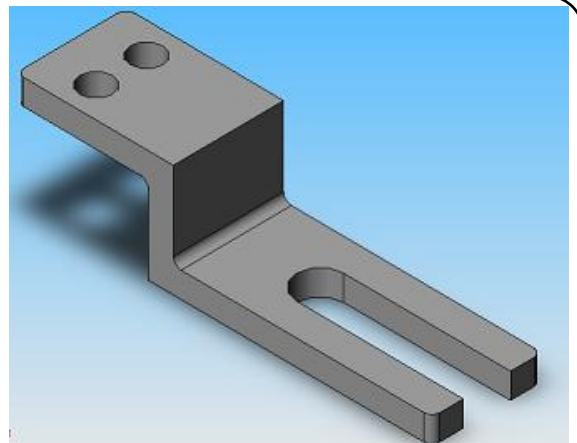

- (h) Digital ebook readers typically have LCD screens. Explain the term LCD.

LCD \_\_\_\_\_

Suggest **one** advantage of an ebook over a paper based book.

Advantage \_\_\_\_\_

\_\_\_\_\_



- (i) Name the plumbing fitting shown and describe its function.

Name \_\_\_\_\_

Function \_\_\_\_\_

\_\_\_\_\_

\_\_\_\_\_



- (j) Name the plumbing fitting shown and suggest where it is used in the hot or cold water system in a house.

Name \_\_\_\_\_

Where used \_\_\_\_\_

\_\_\_\_\_

\_\_\_\_\_



- (k) Name the type of plumbing tape shown and outline why it is used.

Name \_\_\_\_\_

Why used \_\_\_\_\_

\_\_\_\_\_

\_\_\_\_\_



- (l) Calculate the cost of running a 3kW industrial electric heater for 12 hours if each unit of electricity costs 20 cent.

Solution



Industrial electric heater

- (m) A darkness sensing circuit is shown. Name any **four** of the components in this circuit.

- 1 \_\_\_\_\_
- 2 \_\_\_\_\_
- 3 \_\_\_\_\_
- 4 \_\_\_\_\_

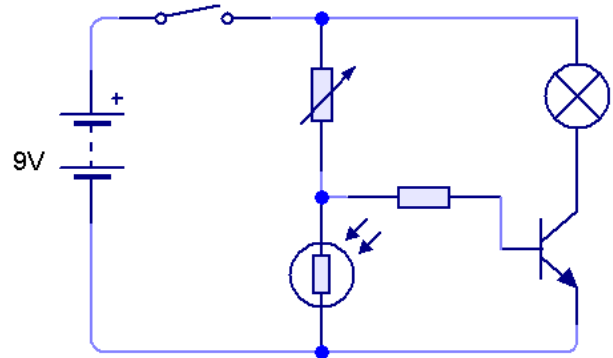

Darkness sensing circuit

- (n) Many engineering and metal fabrication companies are investing in plasma cutting technology. Suggest **two** reasons for this.

- 1 \_\_\_\_\_
- \_\_\_\_\_
- 2 \_\_\_\_\_
- \_\_\_\_\_

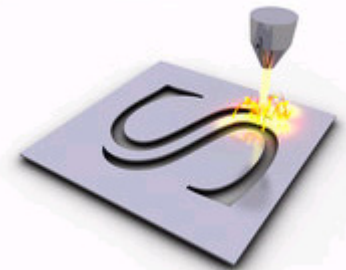

Plasma cutting of steel

- (o) Apply shading to the drawing of the cylinder shown. The shading should help to convey the shape of the cylinder.

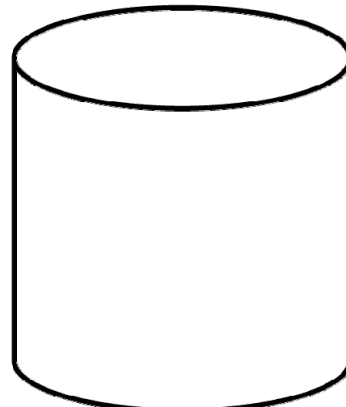

**Compulsory**

**2. Graphical Communication**

- (a) A solid model of a towel rail is shown below.  
In the space opposite draw a well proportioned Elevation and Plan of the towel rail.
- (b) Estimate and include 4 dimensions on your completed drawing.

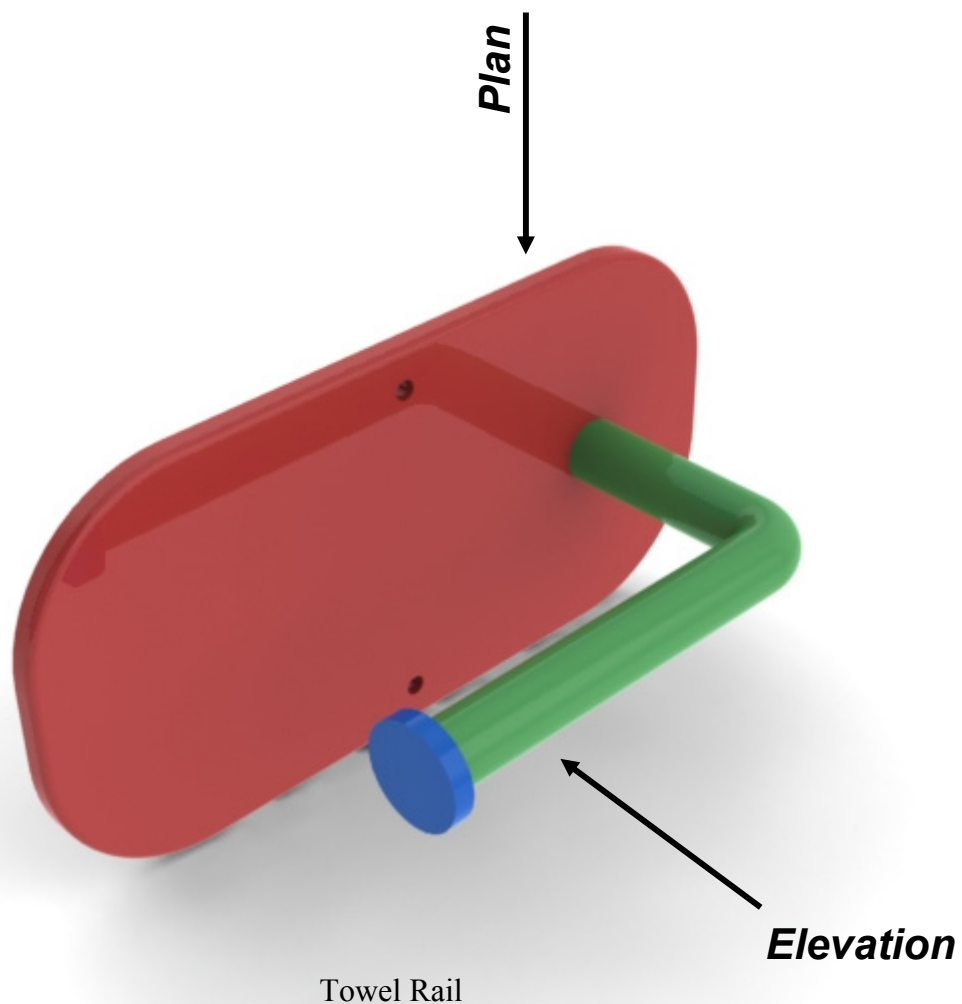

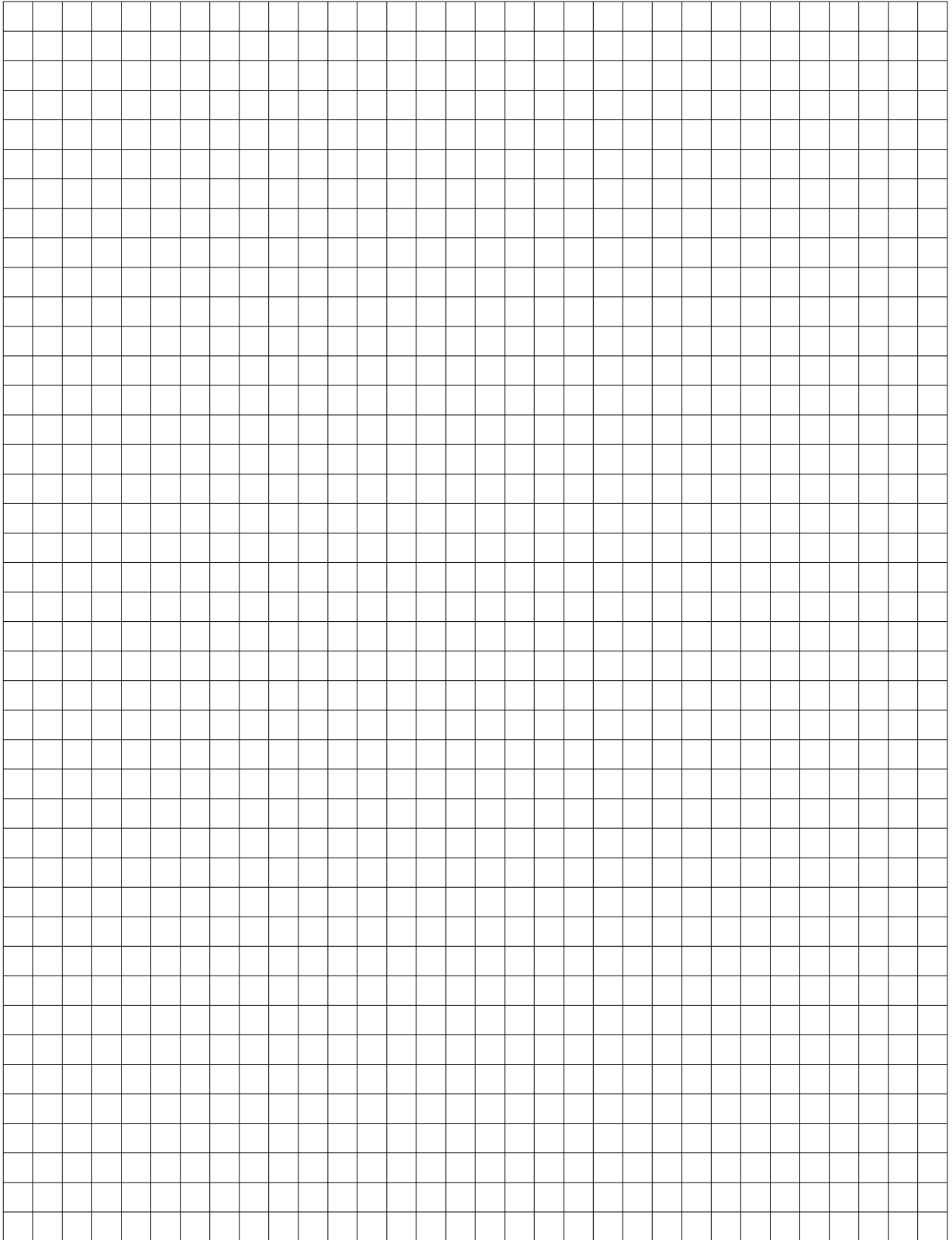

Estimate and include 4 dimensions on your completed drawing.

# Compulsory

## 3. Health and Safety

(a) (i) Suggest **two** reasons for using a spring loaded chuck key when tightening the chuck of a drill or lathe.

1 \_\_\_\_\_  
\_\_\_\_\_

2 \_\_\_\_\_  
\_\_\_\_\_



Spring loaded chuck key

(ii) List **two** precautions that should be observed when using a table saw such as that shown.

1 \_\_\_\_\_  
\_\_\_\_\_

2 \_\_\_\_\_  
\_\_\_\_\_



Table saw

(iii) Identify **two** safety features of the pillar drill shown.

1 \_\_\_\_\_  
\_\_\_\_\_

2 \_\_\_\_\_  
\_\_\_\_\_



Pillar drill



(b) Explain what **each** of the safety signs shown below means.



(c) Outline **two** uses for **each** of the pieces of safety equipment shown.

1 \_\_\_\_\_  
\_\_\_\_\_

2 \_\_\_\_\_  
\_\_\_\_\_



1 \_\_\_\_\_  
\_\_\_\_\_

2 \_\_\_\_\_  
\_\_\_\_\_



1 \_\_\_\_\_  
\_\_\_\_\_

2 \_\_\_\_\_  
\_\_\_\_\_



**Section 2** (150 marks)

Answer **ANY THREE** Questions from this section.

**1. Introducing Technology**

(50 marks)

- (a) An elevation and end view of a hex nut are shown.  
Make a 3D sketch of the nut in the space provided.

3D Sketch

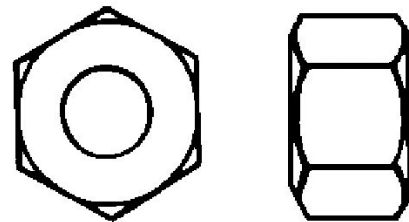

Hex nut

- (b) The toy building blocks shown are made using injection moulding.

- (i) Briefly explain this process.

Answer \_\_\_\_\_  
\_\_\_\_\_  
\_\_\_\_\_  
\_\_\_\_\_

- (ii) List **three** other products that are made using injection moulding.

1 \_\_\_\_\_  
2 \_\_\_\_\_  
3 \_\_\_\_\_



Injection moulded plastic blocks

- (c) (i) Outline the steps required to vacuum form the body for a toy car using the mould and machine shown.

Answer \_\_\_\_\_  
\_\_\_\_\_  
\_\_\_\_\_  
\_\_\_\_\_  
\_\_\_\_\_



- (ii) The choice of plastic for vacuum forming is very important.  
List **two** important characteristics of a suitable plastic for vacuum forming.

1 \_\_\_\_\_  
2 \_\_\_\_\_

- (d) (i) Steel is an example of a ferrous metal.  
What is meant by a ferrous metal?

Answer \_\_\_\_\_

- (ii) Brass and bronze are examples of alloys.  
What is an alloy?

Answer \_\_\_\_\_

- (iii) List **one** advantages and **one** disadvantage of using alloy wheels on a car.

Advantage

\_\_\_\_\_

Disadvantage

\_\_\_\_\_



## 2. Design and Manufacture

(50 marks)

(a) The body of a tape dispenser is shown.

(i) Name a suitable material for **each** of the parts giving a reason for your choice.

Spindle \_\_\_\_\_

\_\_\_\_\_

Base \_\_\_\_\_

\_\_\_\_\_

Side panels \_\_\_\_\_

\_\_\_\_\_

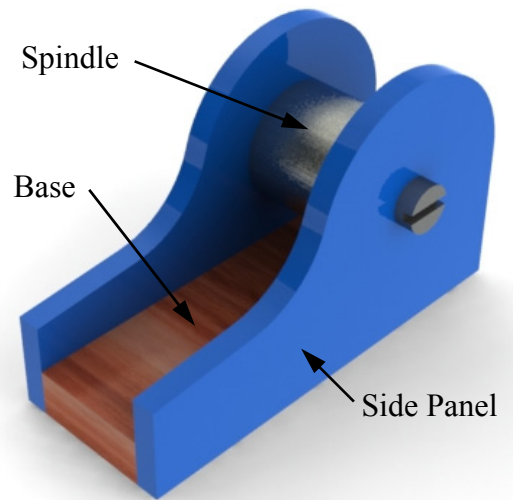

Tape dispenser

(ii) The cutter for cutting the tape is missing from the tape dispenser. In the space below, sketch your design for the cutter and name the material you would make it from.

Cutter Design

Material \_\_\_\_\_

(iii) Use sketches to describe **two** suitable methods of joining the side panels to the base of the dispenser.

Method 1

Method 2

- (b) (i) In the *Design and Manufacture* module you designed and manufactured a product. Name the product you made and make an isometric sketch of it on the grid below.

Product Name \_\_\_\_\_

\_\_\_\_\_

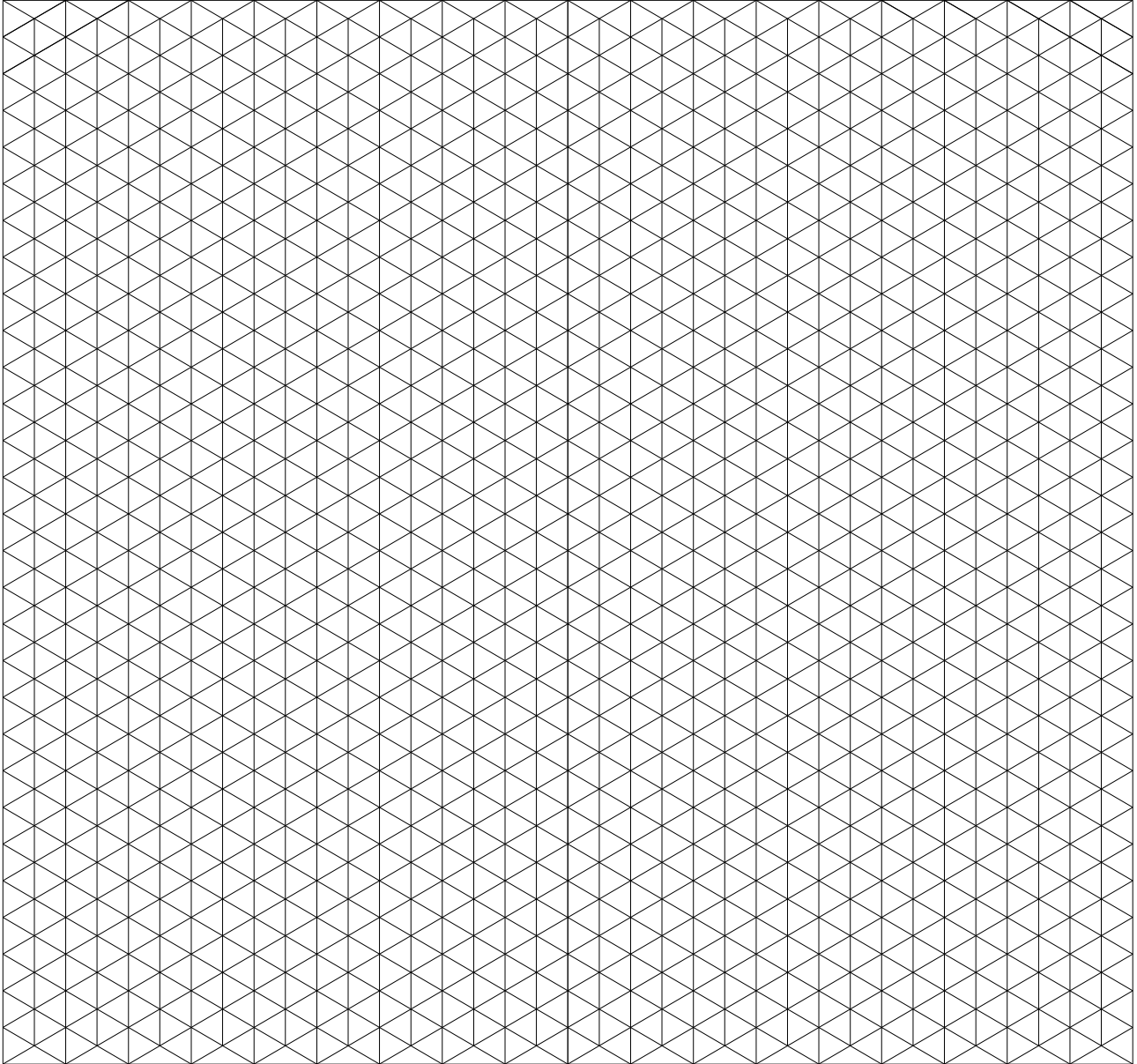

- (ii) What were the **two** most significant things you learned from doing this project?

1 \_\_\_\_\_

\_\_\_\_\_

2 \_\_\_\_\_

\_\_\_\_\_

### 3. Water Technology

(50 marks)

(a) Name the three plumbing fittings shown and give **one** example of where **each** is used.

Fitting 1 \_\_\_\_\_

Use \_\_\_\_\_

\_\_\_\_\_

Fitting 2 \_\_\_\_\_

Use \_\_\_\_\_

\_\_\_\_\_

Fitting 3 \_\_\_\_\_

Use \_\_\_\_\_

\_\_\_\_\_

\_\_\_\_\_



(b) Explain, step by step, how to join a copper pipe to a compression fitting such as that shown.

Answer \_\_\_\_\_

\_\_\_\_\_

\_\_\_\_\_

\_\_\_\_\_

\_\_\_\_\_

\_\_\_\_\_

\_\_\_\_\_

\_\_\_\_\_

\_\_\_\_\_



(c) Energy saving has become very important in all aspects of our lives. Describe **two** ways in which the cost of providing domestic hot water could be reduced.

1 \_\_\_\_\_

\_\_\_\_\_

\_\_\_\_\_

\_\_\_\_\_

2 \_\_\_\_\_

\_\_\_\_\_

\_\_\_\_\_

\_\_\_\_\_

(d) A 240V mains powered submersible water pump for a pond is shown.

(i) Outline **two** advantages of a submersible pump such as this instead of using a pump located above the water.

1 \_\_\_\_\_

\_\_\_\_\_

2 \_\_\_\_\_

\_\_\_\_\_



Pond water pump

(ii) List **three** important considerations to be taken into account when selecting a water pump for a garden pond.

1 \_\_\_\_\_

2 \_\_\_\_\_

3 \_\_\_\_\_

(iii) Name **three** parts of the water pump shown.

1 \_\_\_\_\_ 2 \_\_\_\_\_ 3 \_\_\_\_\_

## 4. Electrical Understanding and Electronics

(50 marks)

- (a) In the table below indicate with a tick (✓) whether each of the materials listed are conductors, semi-conductors or insulators.

Material	Conductor	Semi-conductor	Insulator
Glass			
Copper			
Rubber			
Silicon			
Lead			

- (b) A circuit to light three bulbs is shown.

- (i) Use an (X) to mark the position in the circuit of a switch which will turn off one bulb only.

- (ii) Which bulb will light the brightest and why?

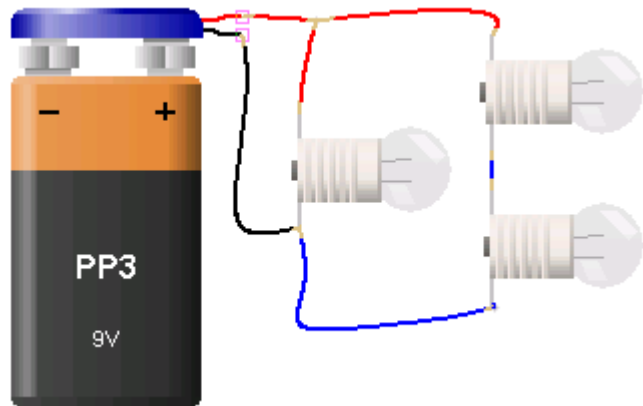

Answer \_\_\_\_\_

\_\_\_\_\_

\_\_\_\_\_

- (ii) Using the correct symbols for the components draw the circuit diagram for this circuit. Include the on/off switch in your diagram.

Circuit diagram



- (c) (i) An RCD is shown.  
What is the purpose of an RCD and what does RCD stand for?

Purpose \_\_\_\_\_  
 \_\_\_\_\_  
 \_\_\_\_\_

RCD \_\_\_\_\_



- (ii) Calculate the cost of running a PC for 5 hours if the power consumption is 250 Watts (0.25 kW) and a unit of electricity costs 20 cent.



- (iii) A CFL Bulb is shown. Explain the term CFL and suggest **three** benefits of using these bulbs instead of filament bulbs.

CFL \_\_\_\_\_

Benefits 1 \_\_\_\_\_  
 2 \_\_\_\_\_  
 3 \_\_\_\_\_



- (iv) A photograph of Poolbeg gas burning electricity generating station is shown.

Outline **three disadvantages** of using fossil fuels such as gas to generate power.

1 \_\_\_\_\_  
 \_\_\_\_\_

2 \_\_\_\_\_  
 \_\_\_\_\_

3 \_\_\_\_\_  
 \_\_\_\_\_



## 5. Tools & Equipment

(50 marks)

(a) A range of equipment found in workshops is shown.

1.



2.

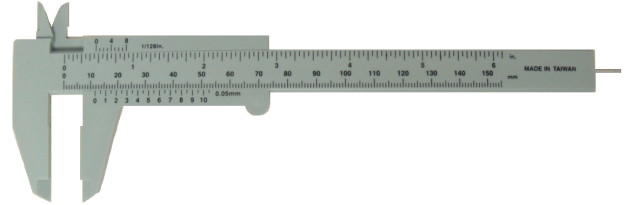

3.



4.



Name each piece of equipment and give its use.

No.	Name	Use
1		
2		
3		
4		

(b) Dust extraction is very important in the workshop. List **four** machines that should have a dust extractor attached.

- 1 \_\_\_\_\_
- 2 \_\_\_\_\_
- 3 \_\_\_\_\_
- 4 \_\_\_\_\_



(c) Make sketches of **any 4** of the following tools in the spaces below.

Try Square	Allen Key	Centre Punch	Scriber	Countersink bit

(d) (i) An MP3 docking station produced by a student is shown.

List **three** machines used in the making of this product.

- 1 \_\_\_\_\_
- 2 \_\_\_\_\_
- 3 \_\_\_\_\_

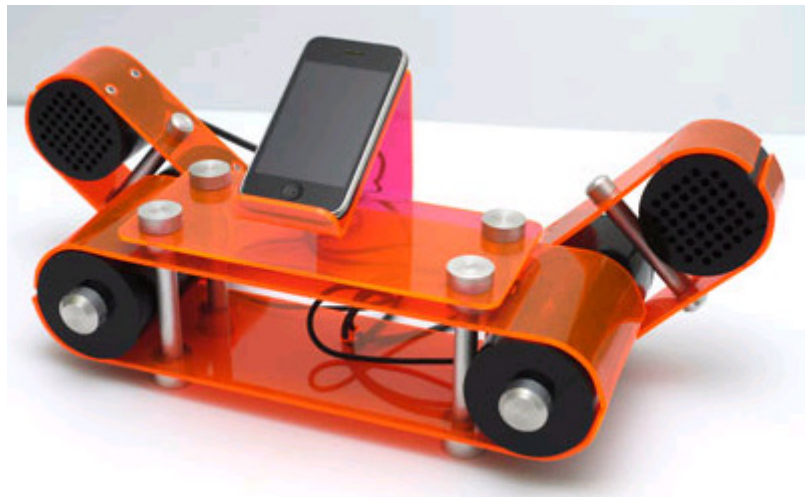

(ii) The amplifier circuit for this product is shown opposite. List **two** pieces of equipment needed to assemble the components of this circuit.

- 1 \_\_\_\_\_
- 2 \_\_\_\_\_



**Blank Page**