



Coimisiún na Scrúduithe Stáit

State Examinations Commission

An Ardteistiméireacht Fheidhmeach, 2015

Speisialachas Gairmiúil

Staidéar Grafaice agus Tógála

(240 marc)

Dé Máirt, 9 Meitheamh, Maidin, 9:30 - 11:00

Treoracha Ginearálta

1. Scríobh do scrúduimhir sa spás seo:
2. Tá dhá roinn sa pháipéar seo.

Roinn 1 - Freagair an dá cheist. **105 marc**
C1 - Ceisteanna gearrfhreagra
C2 - Cumarsáid Ghrafach

Roinn 2 - Cúig cheist - freagair trí cheist ar bith. **135 marc**
C1 - Tógáil
C2 - Seirbhísí Tógála
C3 - Ceardaíocht Adhmaid
C4 - Dearadh agus Déantús
Bréagán Oideachasúil
C5 - Dearadh Ríomhchuidithe

3. Scríobh do chuid freagraí sna spásanna atá ann dóibh agus bíodh sceitsí san áireamh de réir mar is cuí.

Don Scrúdaithe oir amháin		
1.	Iomlán na n-iomlán bunleathanaigh	
2.	Iomlán na gceisteanna dícheadaithe ar fad	
3.	Marc iomlán a bronnadh (1 líude 2)	
4.	Bónasmharc don fhreagairt trí Ghaeilge (más cuí)	
5.	Marc iomlán a bronnadh má bhíonn Bónas Gaeilge i gceist (3 + 4)	
Nóta: Ní mór an marc i gcolún 3 (nó colún 5 má bhronntar Bónas Gaeilge) a bheith mar an gcéanna leis an marc iomlán sa bhosca ar an script.		

Don Fheiteoir amháin			
Stampa an Ionaid			
Roinn		Ceist	Marc
1	(An dá ceann)	1	
		2	
2	(3 cheist ar bith)	1	
		2	
		3	
		4	
		5	
Iomlán			

Roinn 1

ÉIGEANTACH CEIST 1

(60 Marc)

1. Freagair **DHÁ CHEANN DÉAG** ar bith de na **CÚIG CINN DÉAG** de ghearrcheisteanna a leanas.

(a) Ainmnigh an meaisín a thaispeántar.

Ainm: _____

Liostaigh **DHÁ** réamhchúram sábháilteachta ar leith ba chóir a chomhlíonadh agus an meaisín seo in úsáid.

1. _____

2. _____



(b) Ainmnigh an uirlis adhmaadóireachta a thaispeántar.

Ainm: _____

Sa spás atá curtha ar fáil déan sceitse saorlámhe den uirlis seo.



Blank space for drawing the tool.



(c) Taispeánann an léaráid duine agus scanadh á dhéanamh aige do sheirbhísí faoin talamh.

Ainmnigh **TRÍ** sheirbhís atá le fáil faoin talamh.

1. _____

2. _____

3. _____



(d) Is gá 24m^2 de thileanna balla le haghaidh seomra folctha.

(i) Más féidir na tileanna a cheannach i mboscaí de 3m^2 , ríomh an méid bosca is gá don seomra folctha.

(ii) Ta costas €18.50 móide CBL (VAT) de réir 23% ar bhosca tileanna. Ríomh an costas iomlán don chustaiméir ar an ordú thuas.

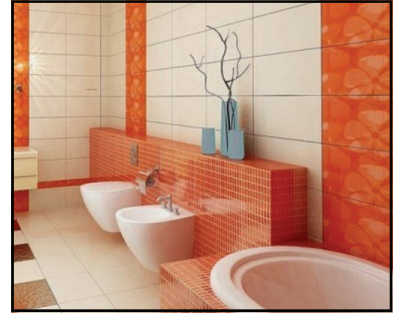

(i)

Freagra: _____ Bosca.

(ii)

Costas iomlán: € _____

(e) Nuair a bhíonn coinchréit á déanamh, déantar í a bhaisceadh de réir cóimheasa.

Más é an cóimheas ná 1:2:3, mar a thaispeántar san iomhá, ainmnigh gach ceann de na comhábhair sna boscaí thíos.

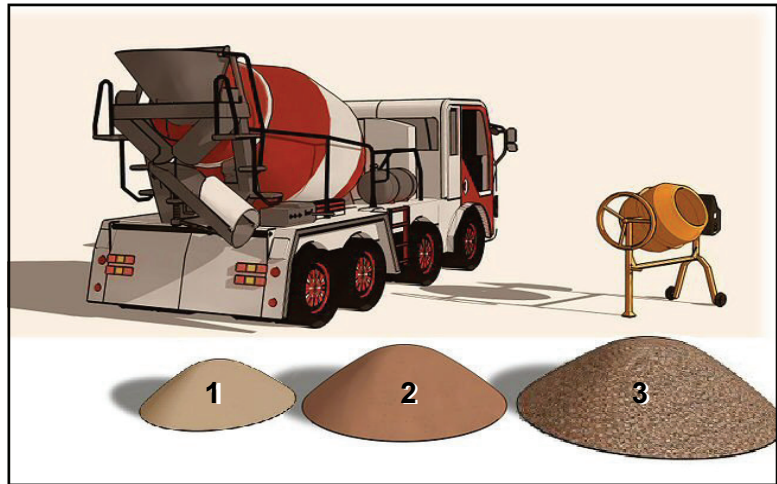

(f) Taispeántar dhá chomhartha toirmisce ar dheis.

Agus na ciorcail thíos á n-úsáid agat, dear comhartha cosúil leo a thugann mar theachtairacht: 'Tá cosc ar an uisce seo a ól'.

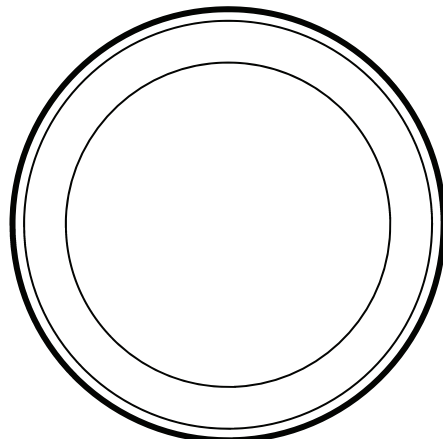

(g) Taispeántar próiseas dearaidh.

Mínigh **DHÁ** chéim ar bith sa phróiseas.

1. _____

2. _____

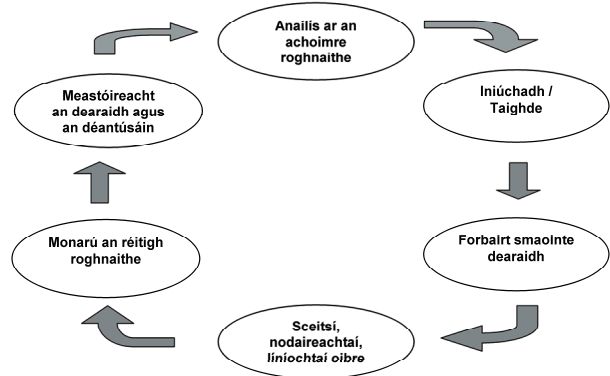

(h) Tá an lógó a thaispeántar ar dheis bunaithe ar thriantán comhshleasach.

Críochnaigh líníocht an lógó thíos.

(Ní gá téacs ná dath a chur isteach.)

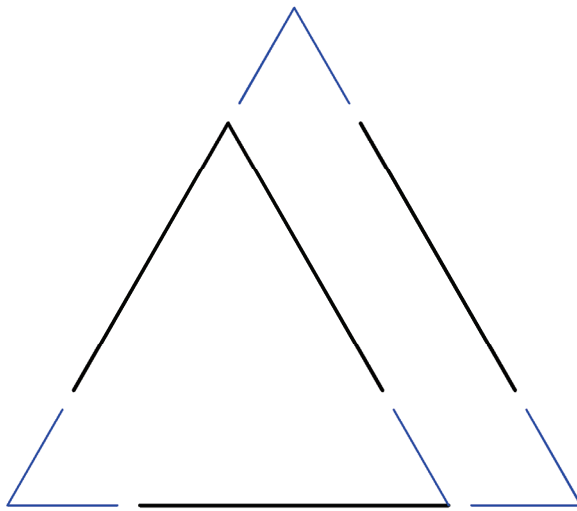

Google Drive



(i) Taispeántar miotal a úsáidtear i dtógáil tithe.

Ainmnigh an miotal: _____

Agus nótaí agus sceitsí á n-úsáid agat, mínigh cá bhféadfaí an t-ábhar seo a úsáid.





- (j) Taispeántar san íomhá máilléad adhmaid.
Cén t-adhmad as a ndéantar máilléid de ghnáth?

Adhmad: _____

Cén fáth a bhfuil an t-adhmad seo oiriúnach chun máilléid a dhéanamh?



- (k) Críochnaigh an lógó "Mario" thíos agus an ghreille a thugtar á húsáid agat.
Cuir dath nó scáthú oiriúnach ar an lógó críochnaithe.

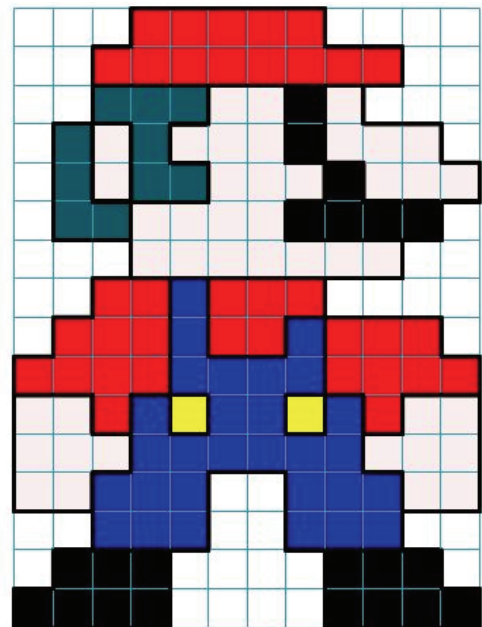
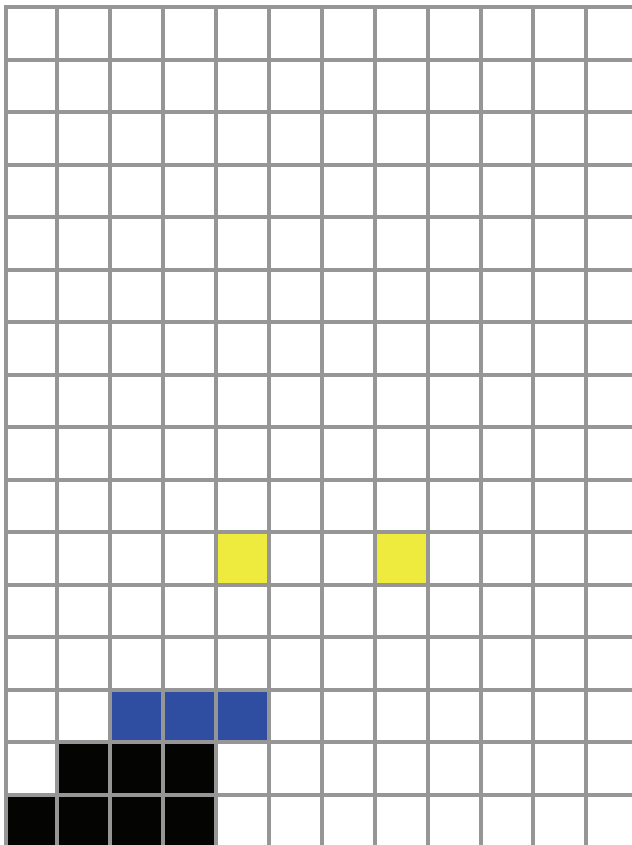

- (l) Ainmnigh **TRÍ** hábhar a úsáidtear chun frámaí fuinneoige a dhéanamh.

1. _____
2. _____
3. _____



(m) Taispeánann an íomhá ar dheis leabhragán a bhfuil trí sheif inmheánacha ann. Taispeánann an dronuilleog thíos fráma imlíneach an leabhragáin. Bain úsáid as tógáil ghrafach chun an fráma a roinnt ionas go mbeidh na trí sheif ar comhfhad óna chéile.



(n) Taispeánann an íomhá puzal i gcruth traenach. Ainmnigh uirlis oiriúnach chun na cuair a ghearradh amach.

Uirlis: _____

Ainmnigh **DHÁ** rud nach mór a chur san áireamh nuair a bhíonn bailchríoch dhromchla á rognú do bhréagán dá leithéid.

1. _____

2. _____

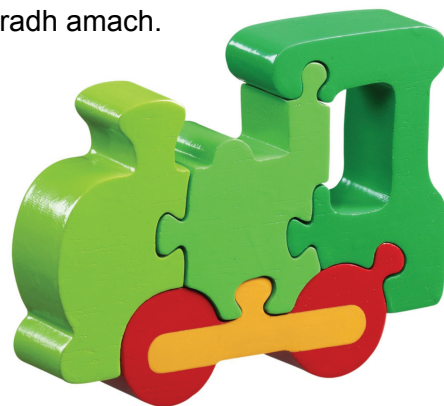

(o) Ainmnigh **DHÁ** fhadhb a d'fhéadfadh tarlú nuair a fhágtar píobáin nocht in aimsir sheaca.

1. _____

2. _____



2. Cumarsáid Ghrafach

(a) Taispeánann an ghrafaic ar dheis cló pictiúrtha de stól adhmaid.

(1) Críochnaigh Ingearchló, Bonnchló agus Taobhchló an stóil ar an líníocht thíos.

(Tá roinnt mionsonraí folaithe atá fágtha ar lár ar mhaithe le soiléire. Níl gá leis na mionsonraí folaithe.)

(2) Cuir dath nó scáthú cuí ar na **clónna críochnaithe** chun feabhas a chur ar an líníocht.

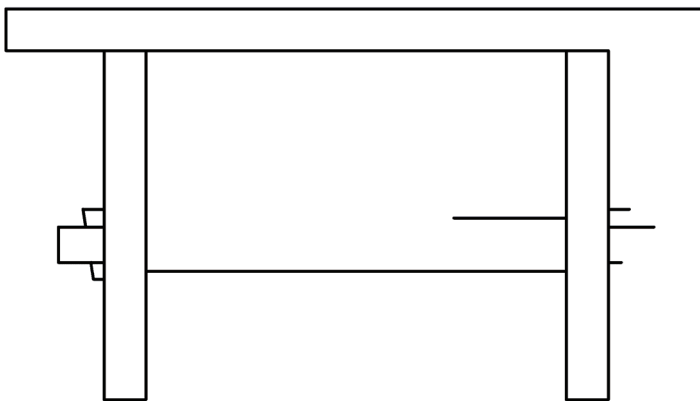

Ingearchló

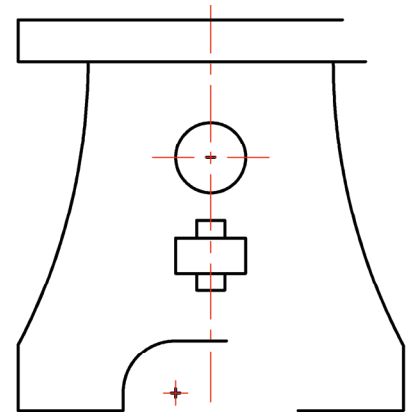

Taobhchló

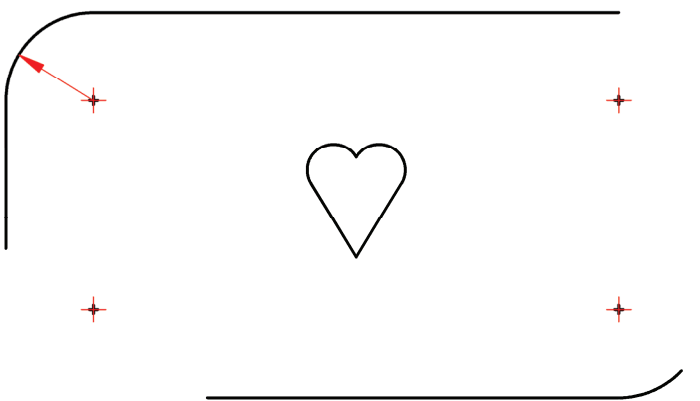

Bonnchló



(b) Taispeánann an íomhá ar dheis foireann liathróidí púil agus bosca triantánach chun iad a stóráil.

Taispeánann an líníocht thíos bonnchló na gcúig liathróid déag.

(1) Ar an líníocht thíos tarraing imlíne an bhosca thriantánaigh is lú is féidir agus na liathróidí a choimeád ann.

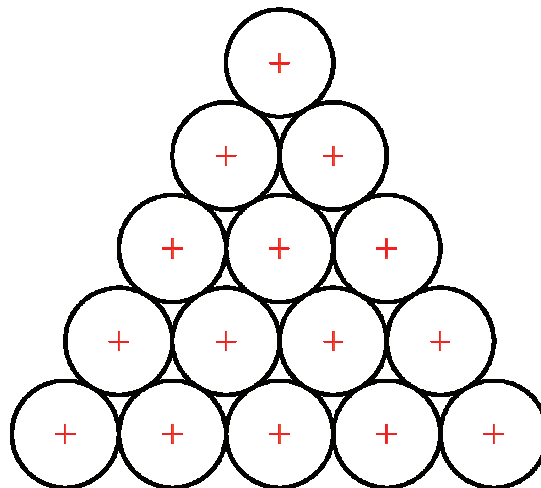

(2) Críochnaigh forbairt dhromchla an bhosca thíos. Tá dhá thaobh tarraingthe cheana féin duit.

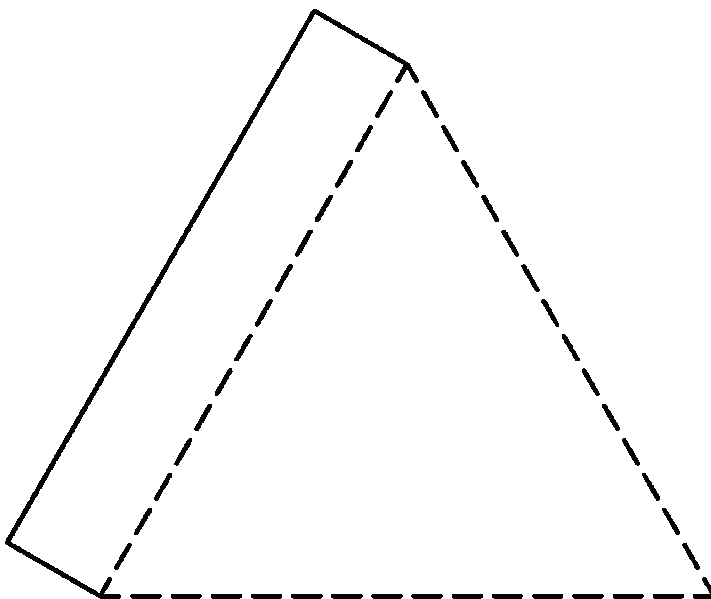

(c) (1) Taispeánann an íomhá ar dheis lógó do chainéal nuachta.

Tá tús curtha le líníocht den lógó thíos. Tá an logo bunaithe ar thriantáin. Críochnaigh an lógó agus cuir dathú cuí leis an líníocht.

(Ní gá an téacs a chur isteach.)

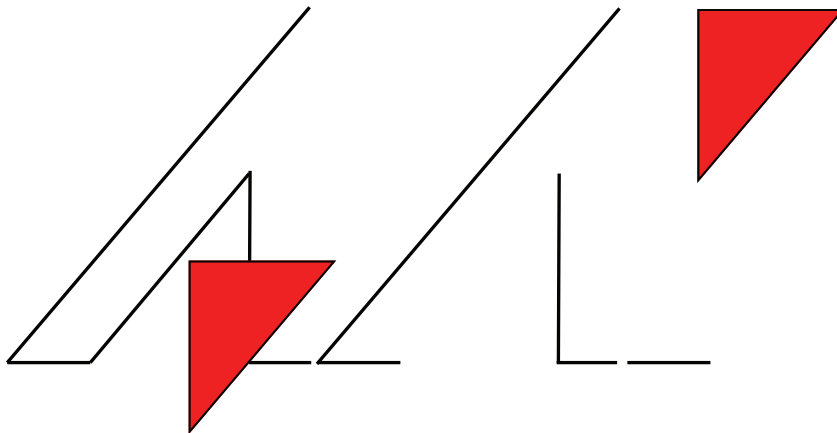

(2) Bain úsáid as na toisí a thugtar ar an líníocht de réir scála thíos, agus ríomh fad 'X'.

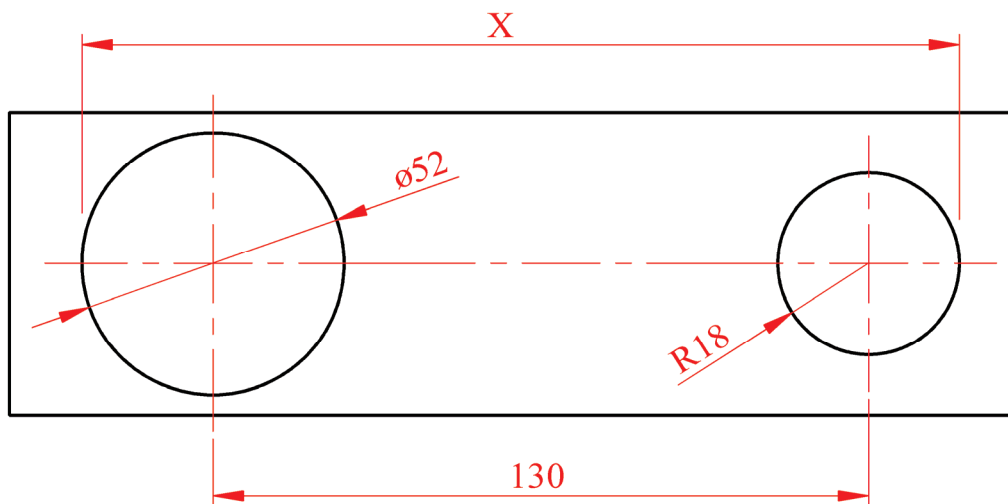

Ríomh X: mm

Roinn 2

(135 Marc)

Freagair TRÍ CINN AR BITH de na ceistanna as an roinn seo.

1. Tógáil

(a) (1) Ainmnigh **CÚIG** pháirt ar bith den doras a thaispeántar.

- A. _____
- B. _____
- C. _____
- D. _____
- E. _____
- F. _____
- G. _____
- H. _____
- I. _____

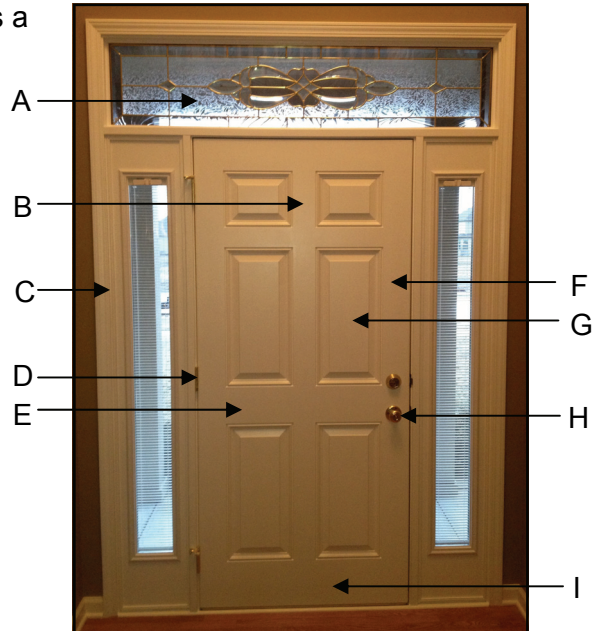

(2) Éilíonn na rialacháin tógála go mbeadh bealach isteach ag cathaoireacha rotha trí dhoirse seachtracha. Ciallaíonn sé sin go gcaithfidh an tairseach a bheith comhréidh. Agus nótaí agus sceitsí á n-úsáid agat, taispeáin conas is féidir é sin a dhéanamh agus cosc a chur ar theacht isteach uisce sa bhfoirgneamh ag an am céanna.



(b) (1) Úsáideann siúinéirí an t-earra a thaispeántar nuair a bhíonn imchásail timpeall ar dhoirse á feistiú.







Ainmnigh an t-earra: _____

(2) Mínigh cén fáth a n-úsáidtear an t-earra sin.



(c) Taispeánann an tábla thíos roinnt earraí a úsáideann plástrálaí.

Ainmnigh **gach** earra agus abair cén úsáid a bhaintear as.

	Mír	Úsáid
1		Ainm. _____ Úsáid. _____ _____ _____
2		Ainm. _____ Úsáid. _____ _____ _____
3		Ainm. _____ Úsáid. _____ _____ _____
4		Ainm. _____ Úsáid. _____ _____ _____
5		Ainm. _____ Úsáid. _____ _____ _____
6		Ainm. _____ Úsáid. _____ _____ _____

2. Seirbhísí Tógála

(a) (1)

(i) Ainmnigh na **TRÍ** chineál gaiste pluiméireachta a thaispeántar thíos.

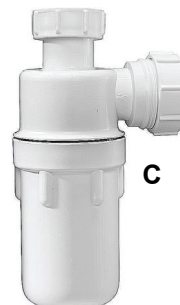
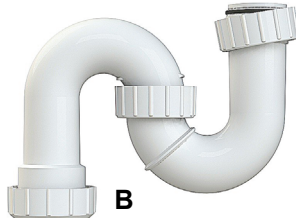
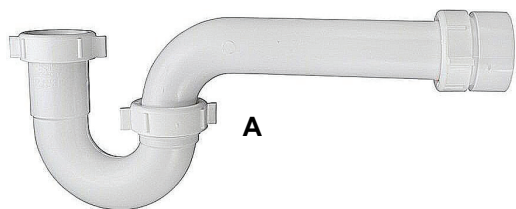

A: _____ B: _____ C: _____

(ii) Roghnaigh **CEANN AMHÁIN** díobh sin thuas agus, ag baint úsáide as nótaí agus sceitsí, abair cá bhféadfaí an gaiste seo a úsáid mar is ceart.

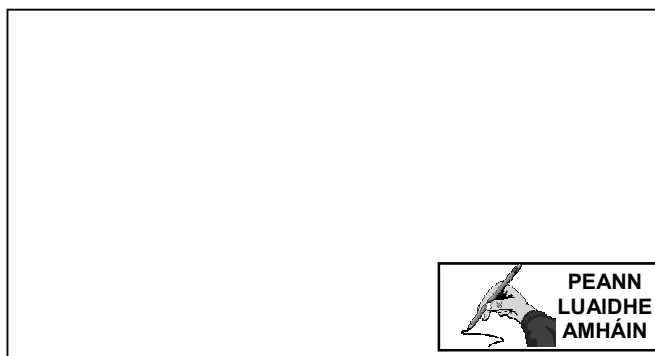

(2) Taispeánann an léaráid doirteal blocáilte (calctha).

(i) Mínigh conas a d'fhéadfadh sé tarlú go mbeadh doirteal blocáilte.



(ii) Mínigh conas a ghlanfá an bhlocáil (calcadh).

(b) (1) Ainmnigh **DHÁ** ábhar a úsáidtear i dtógáil tí chun cosc a chur le cailliúint teasa.

1. _____

2. _____

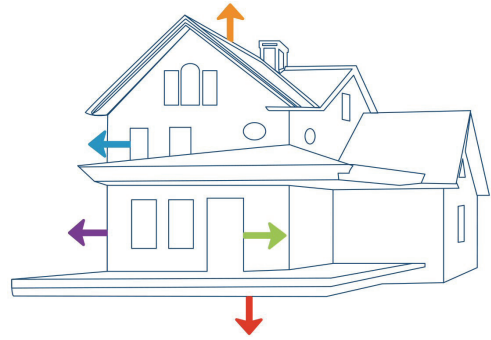

(2) Ainmnigh **TRÍ** háit sa teach ina n-úsáidtear ábhair inslithe agus, ag baint úsáide as nótaí agus sceitsí, mínigh conas a fheistítear an t-insliú chun uaséifeachtacht a chinntiú.

Áit 1. _____

Míniú: _____

Áit 2. _____

Míniú: _____

Áit 3. _____

Míniú: _____



(c) Ainmnigh **TRÍ** bhealach chun úsáid uisce sa teach a laghdú.

1. _____

2. _____

3. _____



3. Ceardaíocht Adhmaid

(a) Taispeántar ceithre hearra a úsáidtear chun adhmaid a shiúntú.

(1) Ainmnigh **gach** earra.



1. _____ 2. _____ 3. _____ 4. _____

(2) Agus úsáid á baint agat as nótaí agus sceitsí, déan cur síos ar cén áit **agus** conas a n-úsáidfí gach ceann de na hearraí sin.



1.

2.

3.

4.

(b) (1) Taispeántar grafaic de dhruilire gan sreang.

Ainmnigh **gach ceann** de na páirteanna a bhfuil lipéad orthu **agus** mínigh an fheidhm a bhaineann le gach ceann acu.



	Ainm	Feidhm
A		
B		
C		
D		
E		
F		

(2) Taispeánann na híomhánna thíos dhá chineál crágán druilire. Ainmnigh **gach** cineál.



1. _____

2. _____

(3) Mínigh go hachomair conas a athraítear béalmhír druilire i ngach ceann de na crágáin thuas.

1. _____

2. _____

(c) Ainmnigh na **TRÍ** bhéalmhír druilire a thaispeántar sna híomhánna thíos agus luaigh úsáid cuí a bhaintear as gach béalmhír.



Ainm: _____

Ainm: _____

Ainm: _____

Úsáid: _____

Úsáid: _____

Úsáid: _____

4. Dearadh agus Déantús Bréagán Oideachasúil

- (a) (1) Ar an ngreille thíos, tarraing mar íomhá scátháin, an leath eile den bhéirín bréige.

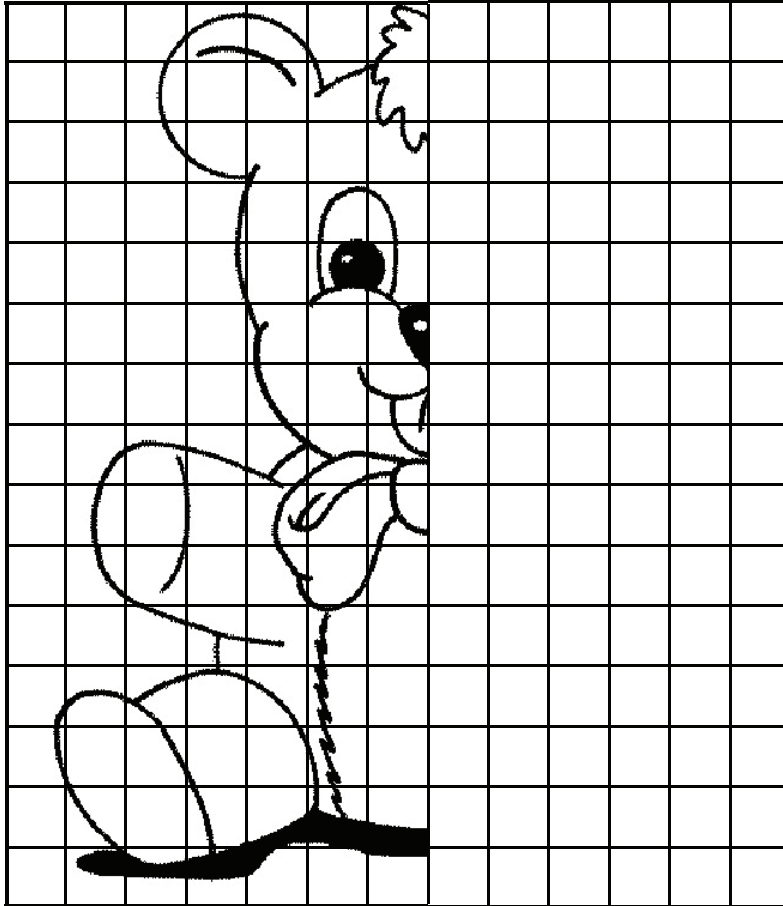

- (2) Taispeánann an íomhá ar dheis leabharthaca.

Ainmnigh alt oiriúnach don áit a bhfuil ciorcal ina timpeall agus déan sceitse néata saorlámhe den alt sa spás atá curtha ar fáil.

Ainm: _____



(b) Mínigh **TRÍ** bhuntáiste a bhaineann le bréagán samplach a bheith agat, amhail an ceann a thaispeántar thall, nuair a bhíonn tú ag beartú bréagán cosúil leis a dhéanamh.

1. _____

2. _____

3. _____



(c) (1) Is reamhchuram tábhachtach sábháilteachta é bailchríoch neamhthocsaineach a bheith ar bhréagán adhmaid.

Luaigh **DHÁ** chúis go mbaineann tábhacht ar leith leis sin i gcás an bhréagáin a thaispeántar san íomhá ar dheis.

1. _____

2. _____



(2) Taispeántar eitleán mionsamhlach cianrialaithe san íomhá thíos. Tá cabhail an bhréagáin le bheith déanta as adhmaid. Ainmnigh adhmaid a bheadh oiriúnach don pháirt sin den bhréagán.

Ainm: _____

Cén fáth gur rogha oiriúnach an t-adhmaid sin don bhréagán áirithe seo?

Cúis: _____



5. Dearadh Ríomhchuidithe

- (a) (1) Ainmnigh **CÚIG** cinn **ar bith** de na gléasanna a thaispeántar sna híomhánna thíos a bhfuil baint acu le Dearadh Ríomhchuidithe.



1. _____ 2. _____



3. _____ 4. _____ 5. _____ 6. _____

- (2) Tá úsáid phrintéirí 3D ag dul i méid sa tionscal CAD. Míniú go hachomair conas a oibríonn printéir 3D.



- (b) Taispeánann an líníocht CAD ar dheis bonnchló ceamara dhigitigh. Agus rialóir á úsáid agat le haghaidh tomhais, cuir isteach go néata sa líníocht sampla de **GACH CEANN** de na cineálacha toisí CAD a leanas:

- (i) Toise Líneach (Cothrománach)
- (ii) Toise Líneach (Ceartingearach)
- (iii) Treoirthoise
- (iv) Toise Ailínithe
- (v) Gathoise.

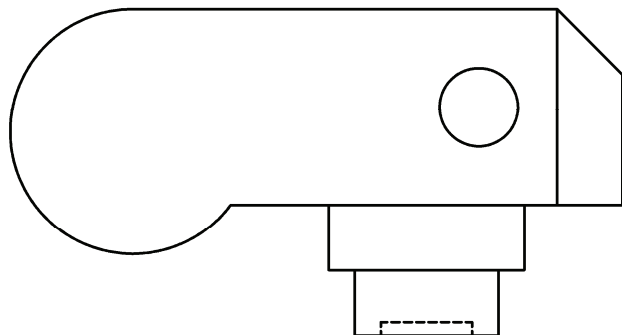

- (c) (1) Ainmnigh pacáiste CAD a d'úsáid tú le linn Staidéar Grafaice agus Tógála a bheith á dhéanamh agat.

Pacáiste: _____

- (2) Liostaigh **CÚIG** ordú/uirlis/ghné CAD a d'úsáidfí chun na líníochtaí thíos a dhéanamh agus mínigh go hachomair cad é a dhéanann gach ordú/uirlis/gné.

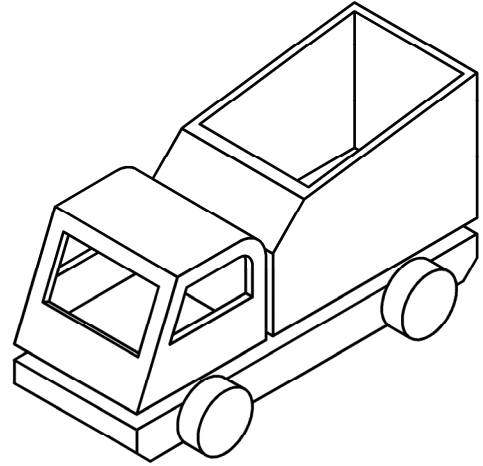
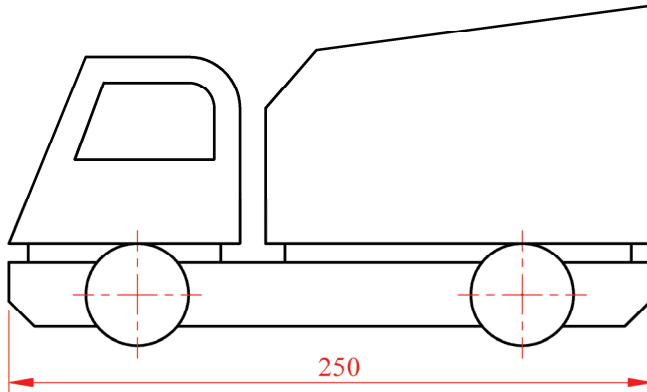

	Ordú/Uirlis/Gné	Cad a dhéanann sé/sí
1	_____	_____ _____
2	_____	_____ _____
3	_____	_____ _____
4	_____	_____ _____
5	_____	_____ _____

- (3) Ainmnigh slí bheatha **AMHÁIN** a bhaineann leis an tionscal CAD agus mínigh go hachomair cad tá i gceist leis an jab a dhéanamh.

Slí bheatha: _____

Cur síos ar an jab: _____

Leathanach
Bán