



Coimisiún na Scrúduithe Stáit
State Examinations Commission

**LEAVING CERTIFICATE
APPLIED 2009**

MARKING SCHEME

**GRAPHICS & CONSTRUCTION
STUDIES**

COMMON LEVEL



Coimisiún na Scrúduithe Stáit
State Examinations Commission

Leaving Certificate Applied - 2009

**Vocational Specialism -
 Graphics and Construction Studies
 (240 marks)**

**Tuesday, June 9, 2009
 Morning, 9.30 am - 11.00 am**

For the Superintendent only

**Marking
 Scheme**

General Directions

1. Write your examination number in this space:

2. There are two sections in this paper.

<i>Section 1</i> - Answer both questions.	- 105 marks
Q1 - Short answer questions	
Q2 - Graphic Communication	
<i>Section 2</i> - Five questions, answer any three .	- 135 marks
Q1 - Construction	
Q2 - Building Services	
Q3 - Woodcraft	
Q4 - Design and Manufacture of Educational Toys	
Q5 - Computer Aided Design	

3. Write your answers in the spaces provided and include sketches as appropriate.

Section 1

COMPULSORY QUESTION 1

(60 Marks)

1. Answer any **TWELVE** of the following **FIFTEEN** short questions.

(a) Explain what is involved in each of the following stages of a Design Process.

1. Investigation/Research: **3 Marks**

2. Evaluation: **2 Marks**

(b) Name a **shaping tool** that you used during this course.

Name: **2 Marks**



In the space provided draw a freehand sketch of the tool.

3 Marks
(Deduct 1 mark if not in pencil)

(c) Explain what is meant by the term '**Sustainable Energy**'.

5 Marks (Example only = 3)

(d) Name the **TWO** types of power tool shown.



2 Marks



3 Marks (partial name = 1)

(e) Describe **ONE** practical skill that you learned during this course.

5 Marks

(f) Name **TWO preservatives** that can be applied to an outdoor woodwork project.

1. **2 Marks** _____

2. **3 Marks** _____

(g) Convert the following dimensions to millimetres.

3.5 cm = _____ mm. **2 Marks**

3.5 m = _____ mm. **3 Marks**

(h) The diagram shown in red below is based on an equilateral triangle. Draw the logo in the space provided given the base AB.



5 Lines correctly drawn @ 1 Mark each

(Deduct 1 mark if not in pencil)

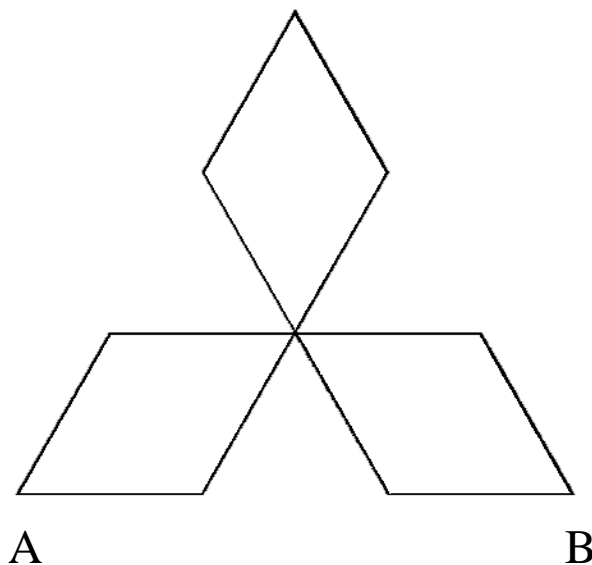
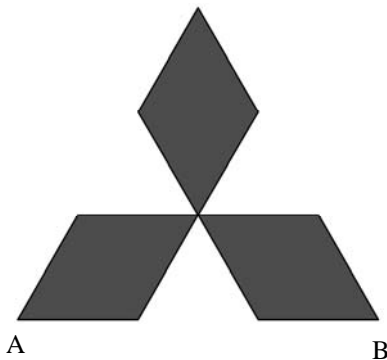

(i) Name the electrical item shown.

Name: **2 Marks** _____

What is the safety reason for using this item on a building site?

Reason: **3 Marks** _____



(j) The diagram shows an assembled view and an exploded view of a woodwork joint.

Name this joint and describe where it could be used in a project.

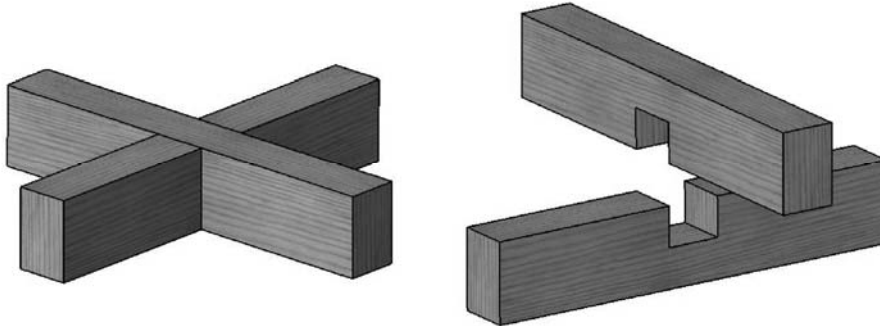

Name: **2 Marks** _____

Use: **3 Marks** _____

(k) The diagram shows an example of a manufactured board.

What is the name of this board?

Name: **3 Marks** _____

Name **TWO** other types of manufactured board.

1. **1 Mark** _____

2. **1 Mark** _____

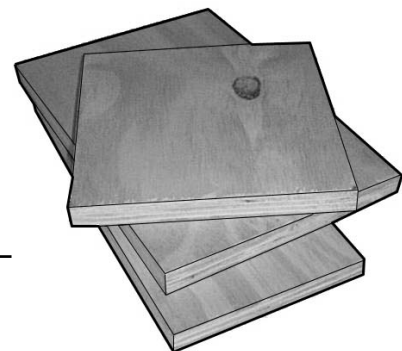

(l) This wooden toy is made from beech.

List **TWO** reasons why beech is a suitable wood for use in the toy.



1. **3 Marks** _____

2. **2 Marks** _____



(m) The pictures below show people working in various building trades.

Name each person's trade and briefly describe their job on a building site.

Picture	Trade	Job Description
	_____	_____
	_____	_____
	_____	_____

2 Marks for any 1st Trade and Description (1 mark each)

2 Marks for any 2nd Trade and Description (1 mark each)

1 Mark for any 3rd Trade and Description (1 or 0)

(n) What do the letters C.A.D. stand for in regard to Graphics and Communication?

C. **2 Marks** _____

A. **2 Marks** _____

D. **1 Mark** _____



(o) Two types of upper floor construction are shown below.
Name each floor type and give **TWO** advantages in each case.



Name: **1 Mark** _____

Name: **1 Mark** _____

Advantage 1: **1 Mark** _____

Advantage 1: **1 Mark** _____

Advantage 2: _____
1 Mark for a 2nd advantage of either floor type

Advantage 2: _____
1 Mark for a 2nd advantage of either floor type

Section 1

COMPULSORY QUESTION 2

(45 Marks)

2. Graphic Communication

The graphic on the right shows a pictorial view of a stool.

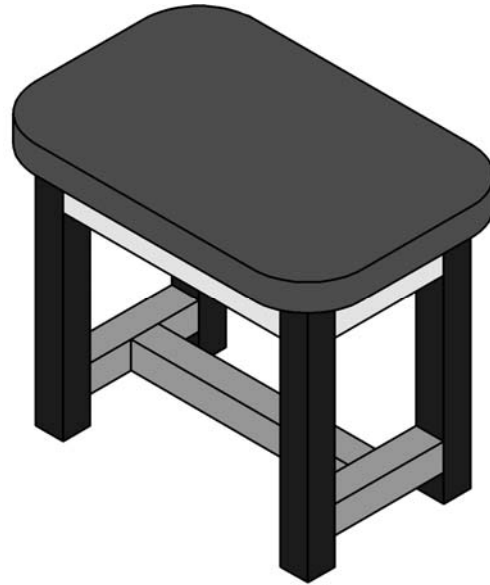

- (a) Complete the Elevation, Plan and End View of the stool on the drawing below.
- (b) Apply appropriate colour or shading to the finished drawing.

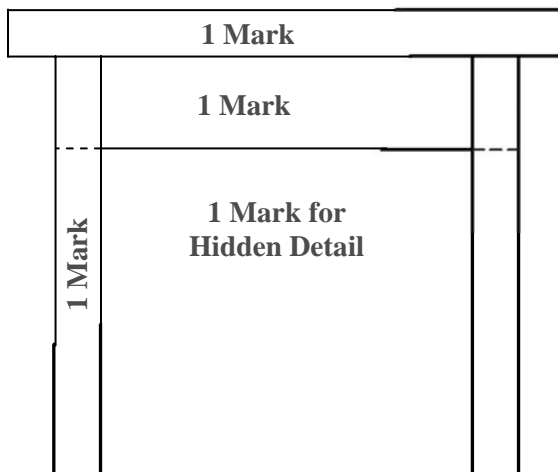

4 Marks in Total
(Deduct 1 mark if not in pencil)

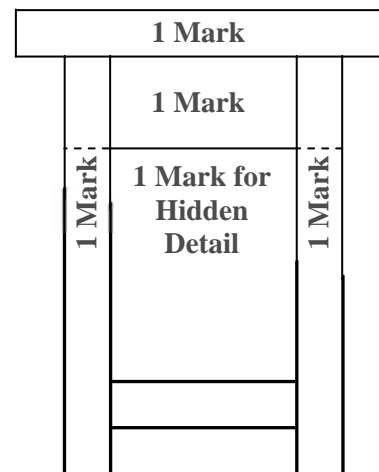

5 Marks in Total
(Deduct 1 mark if not in pencil)

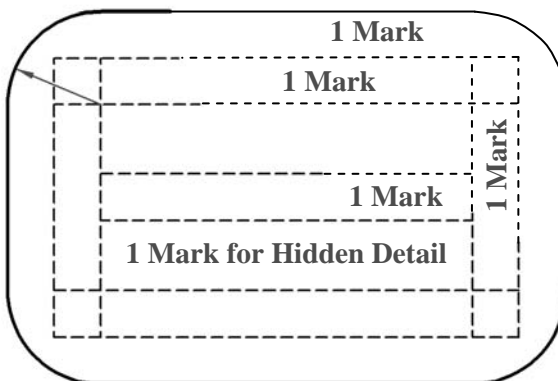

5 Marks in Total (Deduct 1 mark if not in pencil)

**1 Mark for
Colour/Shading**



15

(b) The picture shows a portable DVD player.

On the grid below draw a well proportioned isometric sketch of the DVD player with the screen in the open position as shown.



Base = 5 Marks

Screen = 4 Marks

Large circle = 3 Marks

**Small circle
& Buttons = 3 Marks**

(Deduct 3 marks if not in pencil)

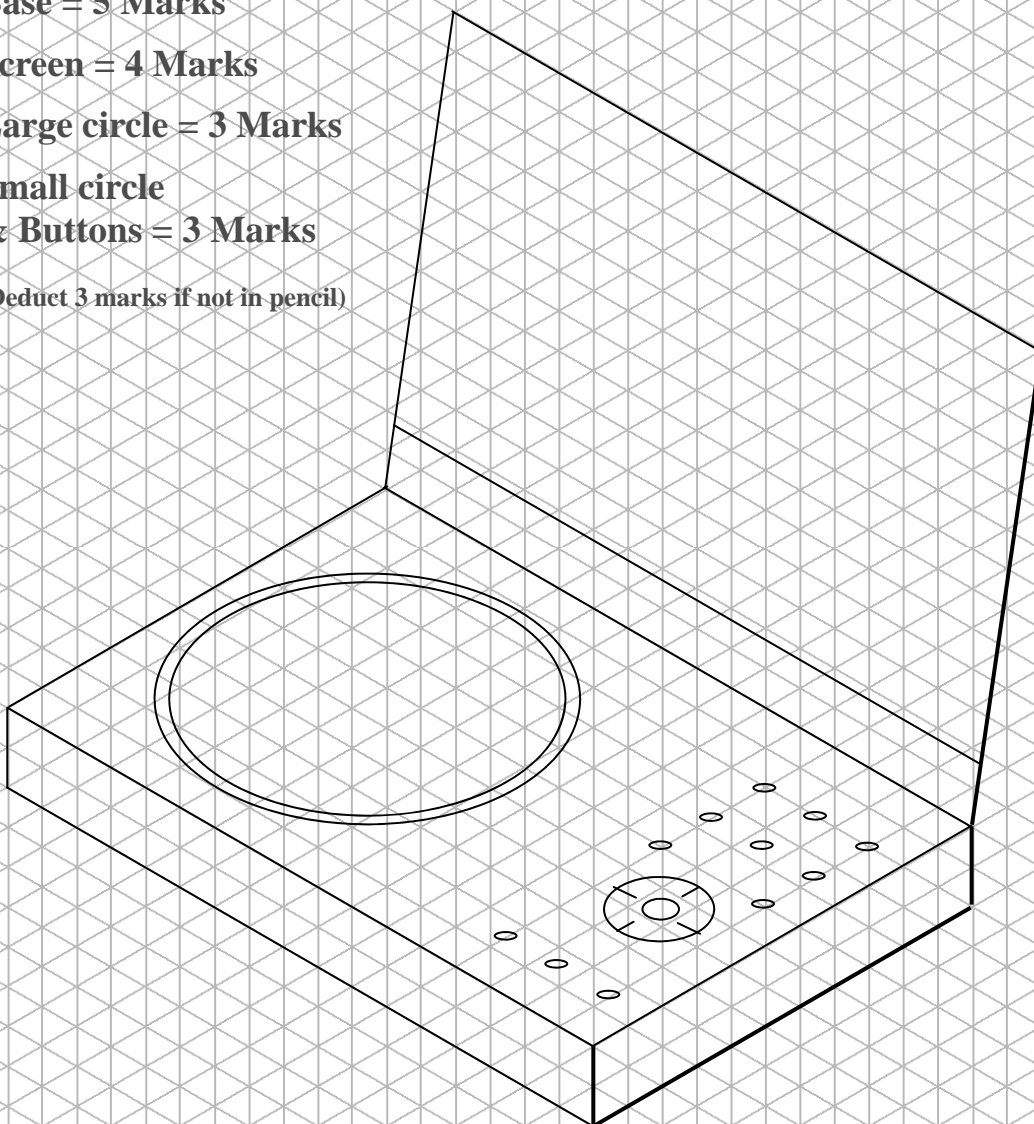

15

- (c) The drawing on the right shows a padlock.
Using the given dimensions, complete the drawing of the padlock below.

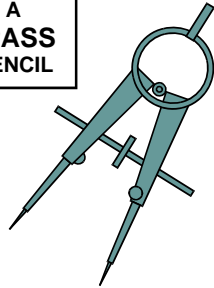

- 35mm Circle = 3 Marks**
- 15mm Circles = 2 x 3 Marks**
- 45mm Circles = 2 x 2 Marks**
- 23mm Circle = 1 Mark**
- 31mm Circle = 1 Mark**

(Deduct 3 marks if not in pencil)

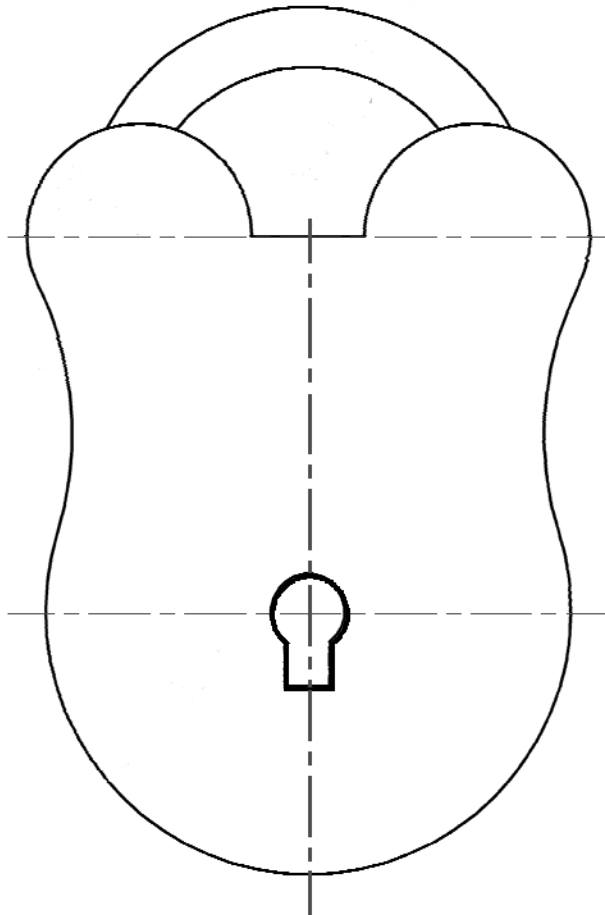

Section 2

(135 Marks)

Answer ANY THREE Questions from this section.

1. Construction

- (a) Before development can begin on a building site, Planning Permission must be obtained. Briefly explain the difference between Outline Planning Permission and Full Planning Permission.

Outline Planning Permission: 8 Marks

Full Planning Permission: 7 Marks

15

- (b) Shown is a diagram of an external wall of a timber framed house.

Identify any **FIVE** of the nine Components shown.

1. Plasterboard

2. Timber Stud

3. Wall Tie

4. Vapour Barrier

5. Insulation

6. Plywood/Sheeting

7. Cavity/Breather Membrane

8. Brick/Block work

9. Cavity/Breather Membrane

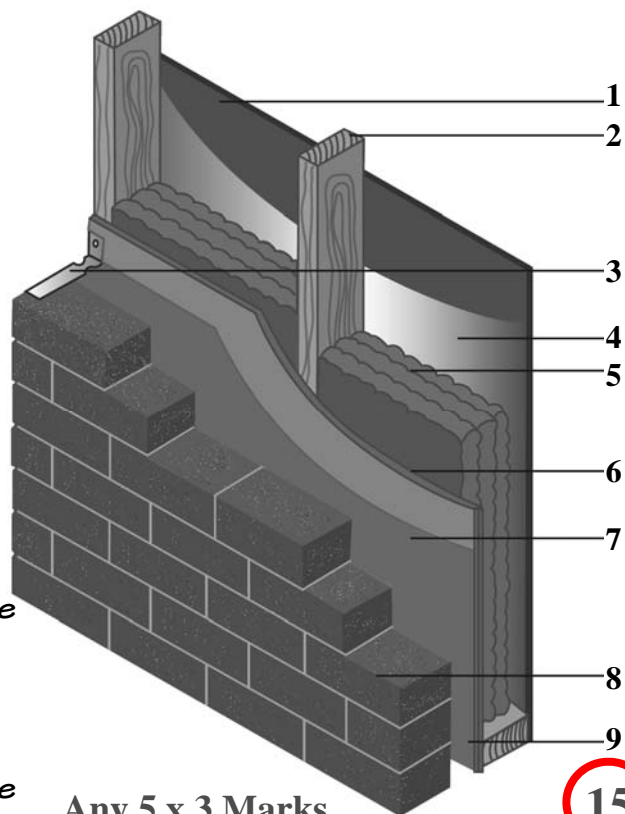

Any 5 x 3 Marks

15

- (c) There are 6 typical steps involved in fitting a door lock. The first step is completed below.
- (1) Explain what is happening in the diagrams in steps two, three and four below.
 - (2) In the boxes provided sketch stages five and six to match the given descriptions.

1.

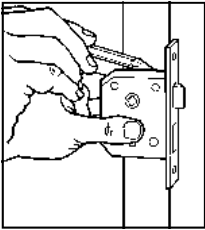

Using a pencil, mark out the size and position of the lock on the edge of the door.

2.

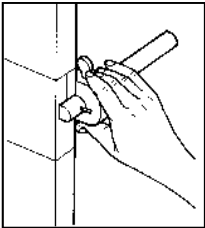

3 Marks

3.

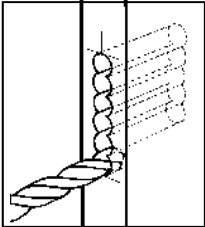

3 Marks

4.

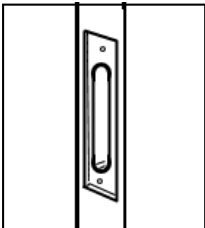

3 Marks

5.

3 Marks
(Deduct 1 mark if not in pencil)

Mark out the centre points and drill the holes for both the handle and the key.

6.

3 Marks
(Deduct 1 mark if not in pencil)

Complete the fixing of both the lock and handle.



15

2. Building Services

- (a) (1) Shown below are FOUR components used in plumbing systems.
Name each component and briefly state what each one is used for.



Name: **1 Mark** _____

Use: **2 Marks** _____



Name: **1 Mark** _____

Use: **2 Marks** _____



Name: **1 Mark** _____

Use: **2 Marks** _____



Name: **1 Mark** _____

Use: **2 Marks** _____

- (a) (2) Name **TWO** materials that are used in the manufacture of pipes.

1. **2 Marks** _____

2. **1 Mark** _____

- (b) (1) Shown is a list of energy sources used to generate electricity.
Using a tick, identify whether the source is renewable or non renewable.

ENERGY SOURCE	RENEWABLE	NON RENEWABLE	
Oil		✓	2 Marks
Gas		✓	2 Marks
Wind	✓		2 Marks
Wood	✓		2 Marks
Coal		✓	2 Marks

- (b) (2) Name **TWO** ways in which electricity may be conserved in the home.

1. **3 Marks** _____
2. **2 Marks** _____

15

- (c) (1) Name the **TWO** types of insulation shown below and suggest a location in the home where they could be used.



Name: **2 Marks** _____

Location: **3 Marks** _____

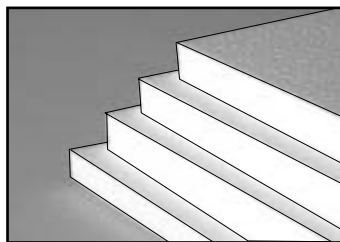

Name: **2 Marks** _____

Location: **3 Marks** _____

- (c) (2) Briefly outline **TWO** ways of making a new house more energy efficient at the design stage.

1. **3 Marks** _____
- _____

2. **2 Marks** _____
- _____

15

3. Woodcraft

- (a) Shown are a number of bits commonly used for drilling different materials.
Name each of the drill bits and suggest a material they would be suitable for drilling.



Name: 2 Marks

Material: 2 Marks



Name: 2 Marks

Material: 2 Marks



Name: 2 Marks

Material: 2 Marks



Name: 1 Marks

Material: 2 Marks

15

- (b) Identify **THREE** possible accidents which could occur in a woodcraft workshop, and list **THREE** precautions that could be taken to help prevent them.

Possible Accidents:

1. 3 Marks

2. 3 Marks

3. 3 Marks



Precautions:

1. 2 Marks

2. 2 Marks

3. 2 Marks

15

(c) The diagram shows a bookcase storage unit.

(1) Name a suitable material that could be used in the sides and shelves of this unit.

Material: 3 Marks (Wood = 1 mark)



(2) Briefly describe a method of joining the shelves to the side of the bookcase.

5 Marks

(3) In the space provided below, sketch a design improvement to make the bookcase more attractive.

7 Marks

(Deduct 2 marks if not in pencil)



15

4. Design and Manufacture of Educational Toys

(a) Two similar toys are shown below. **One** is made from **plastic** and **one** is made from **wood**.

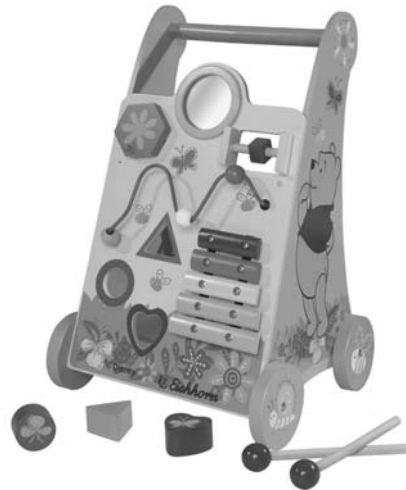

Evaluate each toy under the headings listed below.

	Materials and the Environment 3 Marks	
	Manufacture 3 Marks	
	Safety 3 Marks	
	Cost 3 Marks	
	Educational Value 3 Marks	

(b) The diagram shows a toy insect with a mechanism.

- (1) Suggest a hand tool used to shape the body of the insect.

Hand Tool: **3 Marks** _____

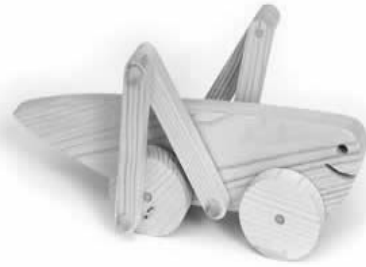

- (2) Name the mechanism used and describe how it works.

Name = 4 Marks

Description = 8 Marks

15

(c) The diagram shows a toy train.

- (1) What is the main **educational value** of the toy?

2 Marks



- (2) Explain how you would transfer the numbers from a printed sheet of paper to the wood.

4 Marks

- (3) Name a **saw** that could be used to cut out the numbers.

Name: **3 Marks** _____

- (4) Sketch an **alternative design idea** for each carriage instead of using numbers?



6 Marks

(Deduct 1 marks if not in pencil)

(You need only show 2 carriages in your sketch)

15

5. Computer Aided Design

(a) Identify each of the CAD commands/tools required to produce the modified drawing from the original drawing below.

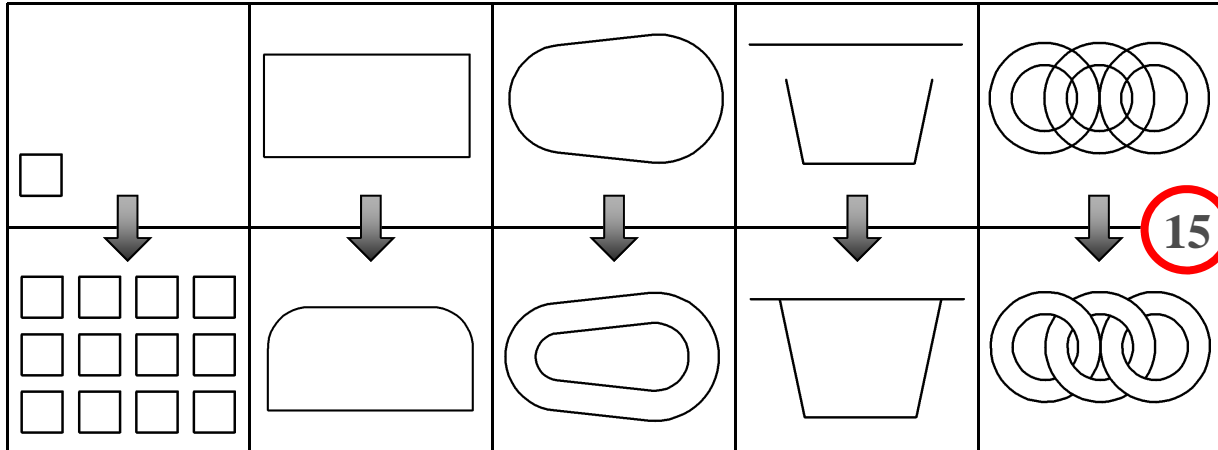

15

3 Marks



3 Marks

3 Marks

3 Marks

3 Marks

(b) Three data storage devices are shown below. Identify each device, give a typical use and give **ONE** advantage **or** disadvantage of each device.

			
Name	2 Marks	2 Marks	2 Marks
Typical Use	2 Marks	2 Marks	2 Marks
Advantage or Disadvantage	1 Mark	1 Mark	1 Mark

15

- (c) (1) Name a CAD package that you have used while studying Graphics and Construction Studies.

Package: 5 Marks

- (2) The graphic on the right shows a 3D view of digital camera. The drawing below shows the plan, elevation and end view of the camera.

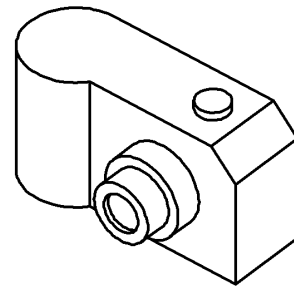

List **FIVE** CAD commands/tools/features that would be used to draw the camera and briefly explain what each command/tool/feature does.

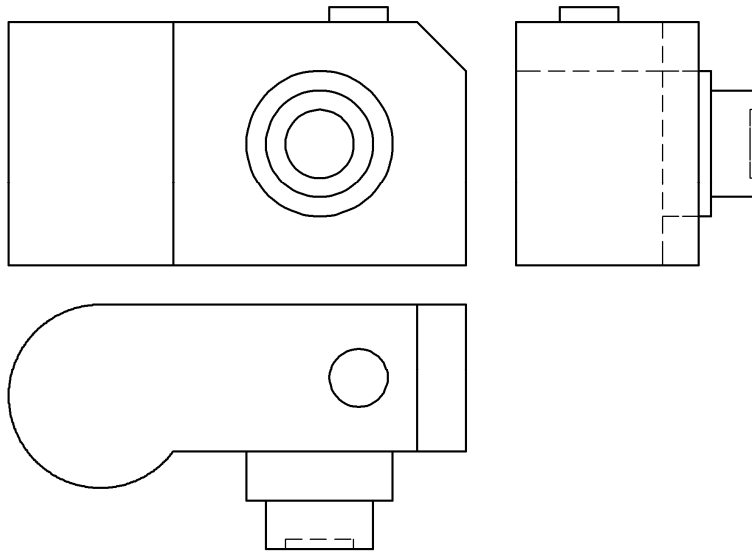

Command/Tool/Feature		What it does
1	<u>1 Mark</u>	<u>1 Marks</u>
2	<u>1 Mark</u>	<u>1 Marks</u>
3	<u>1 Mark</u>	<u>1 Marks</u>
4	<u>1 Mark</u>	<u>1 Marks</u>
5	<u>1 Mark</u>	<u>1 Marks</u>

15

Blank Page