



# Coimisiún na Scrúduithe Stáit

An Ardteistiméireacht Fheidhmeach – 2008

## Speisialachas Gairmiúil – Grafaic & Staidéar Tógála (240 marc)

Dé Máirt, 10 Meitheamh 2008

Maidin 9.30 am – 11.00 am

*Don Fheitheoir Amháin*

Stampa an Ionaid

### ***Treoracha Ginearálta***

1. Scríobh do scrúduimhir sa spás seo :

2. Tá dhá roinn sa pháipéar seo.

Roinn 1 – Freagair an dá cheist

- 105 marc

**C1 – Ceisteanna gearrfhreagra**

**C2 – Cumarsáid Ghrafach**

Roinn 2 – Cúig cheist; freagair trí cheist ar bith

- 135 marc

**C1 – Tógáil**

**C2 – Seirbhísí Tógála**

**C3 – Ceardaíocht Adhmaid**

**C4 – Dearadh agus Déantús Bréagán Oideachasúil**

**C5 – Dearadh Ríomhchuidithe**

3. Scríobh do chuid freagraí sna spásanna atá curtha ar fáil dóibh agus bíodh sceitsí san áireamh de réir mar is cuí.

# Roinn 1

# ÉIGEANTACH CEIST 1

(60 Marc)

1. Freagair DHÁ CHEANN DÉAG ar bith de na CÚIG CHEIST DÉAG seo a leanas.

(a) Ainmnigh an uirlis a thaispeántar.

Ainm: \_\_\_\_\_



(b) Críochnaigh an léaráid den leathalt crosach a thaispeántar.

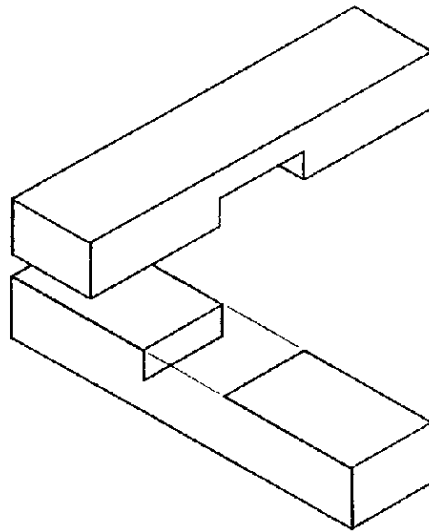

(c) Mínigh cad is ciall leis an téarma 'FEISTITHE SO-SCAOILTE'.

\_\_\_\_\_

\_\_\_\_\_

(d) Ainmnigh an **DÁ** chineál uirlisí cumhachta a thaispeántar.

1



1

\_\_\_\_\_

2



2

\_\_\_\_\_

(e) Mínigh an téarma 'Tógáil Lasmuigh den Suíomh'.

---

---

---

(f) Liostaigh **DHÁ** thoisic is ceart a chur san áireamh nuair a bhíonn bailchríoch á cur ar thionscadal adhmaadóireachta.

1. \_\_\_\_\_

2. \_\_\_\_\_

(g) Taispeántar druilire cumhachta gan chorda. Luaigh **DHÁ** bhuntáiste a bhaineann le huirlisí cumhachta gan chorda a úsáid.



Buntáiste 1: \_\_\_\_\_

Buntáiste 2: \_\_\_\_\_

(h) Tá an dearadh don bhord a thaispeántar bunaithe ar heicseagán rialta. Tarraing heicseagán rialta ar an slios AB a thugtar thíos.



A \_\_\_\_\_ B



(i) Taispeántar geata adhmaid. Cad é an t-ainm ceart ar an bhfórsa atá ag gníomhú ar bhall A?

COMHBHRÚ

TOIRSIÚN

TEANNAS

FIAR

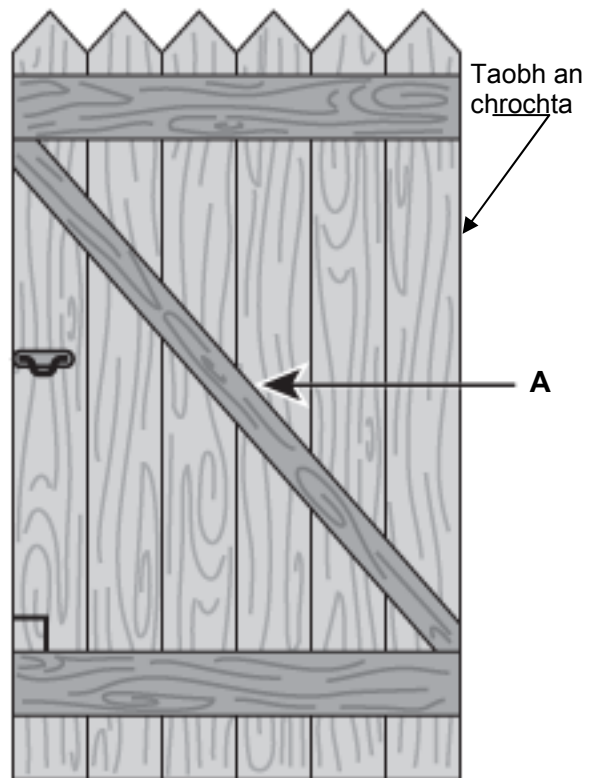

(j) Taispeánann an léaráid dhá chló d'alt a úsáidtear in adhmaid, ceann acu cóimeáilte agus ceann scartha. Ainmnigh an t-alt a thaispeántar agus luaigh sampla amháin d'áit a bhféadfaí an t-alt seo a úsáid.

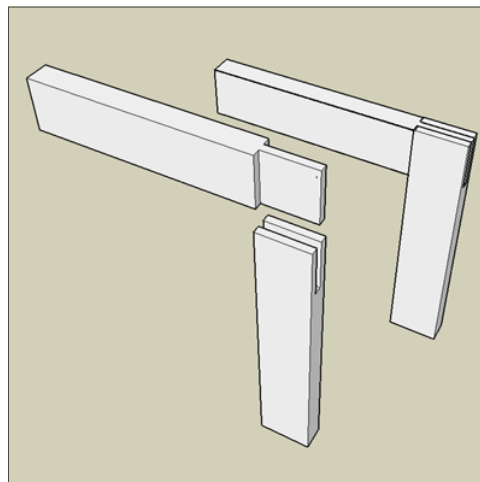

Ainm : \_\_\_\_\_

Úsáid: \_\_\_\_\_

\_\_\_\_\_

- (k) Taispeánann an léaráid cábla leictreach 3 chroíleacán. Sainaithin gach sreang tríd an ainm ceart a roghnú ón liosta thíos:



**Liosta: Talamh, Beo, Neodrach**

Donn: \_\_\_\_\_

Gorm: \_\_\_\_\_

Glas agus buí \_\_\_\_\_

- (l) Taispeánann an léaráid raca litreacha. Críochnaigh an liosta gearrtha don raca litreacha. (Tá an t-ábhar go léir 10 mm ar tiús.)

Cur síos	Cainníocht	Fad	Leithead	Tiús
Bonn	1		120	10
Cúl	1	250		10
Aghaidh	1		80	
Taobh-anna		70	80	10

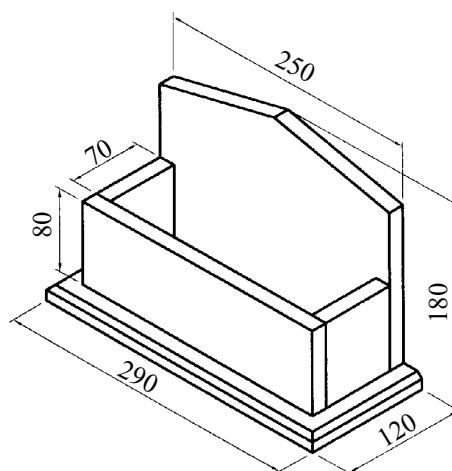

- (m) Taispeánann an léaráid córas ulóige neamhchríochnaithe le haghaidh deile. Taispeáin ar an léaráid an áit a gcuirfeá an crios chun an luas is lú a bhaint amach ar an deil.

**Seafta Fearsaide**

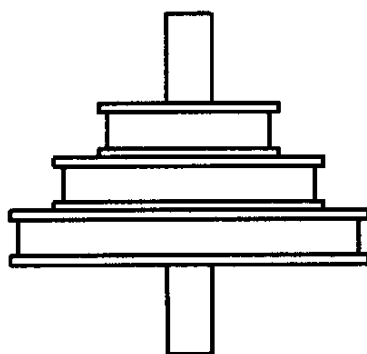

**Seafta Mótair**

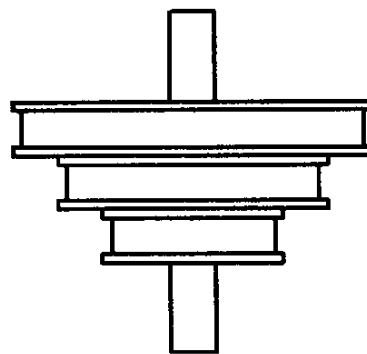

(n) Baintear úsáid go coitianta as griansoilse gairdín sa lá inniu.

Liosta **DHÁ** úsáid eile don ghrianteicneolaíocht a bhfuil baint acu leis an tógáil.



1.

---

---

2.

---

---

(o) Taispeánann an léaráid céatadán an teasa a chailtear trí imchlúdach an tí. Mol **DHÁ** bhealach a bhféadfaí cailleadh an teasa as teach a laghdú.

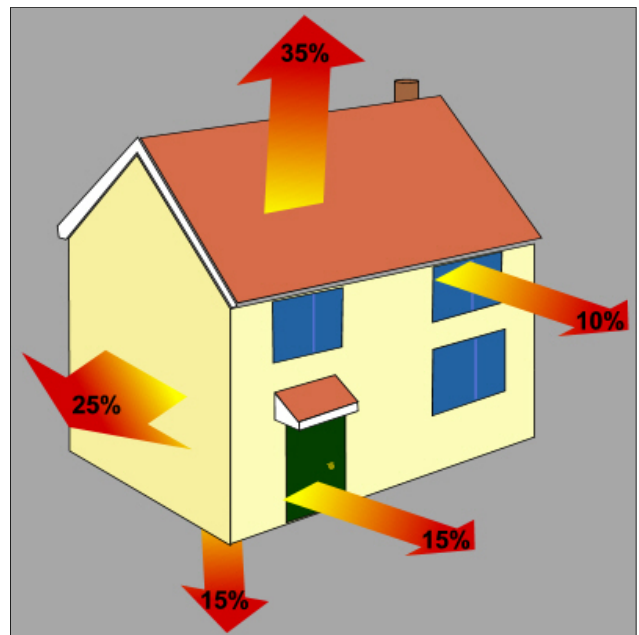

1.

---

---

2.

---

---

2. Cumarsáid Ghrafach

Taispeánann an sceitse córas líníochta

- (a) (1) Cuir ciorcal timpeall ar ainm ceart an chórais líníochta seo ón liosta seo a leanas:

**Teilgean Fiar**

**Teilgean Ortagrafach**

**Teilgean Isiméadrach**

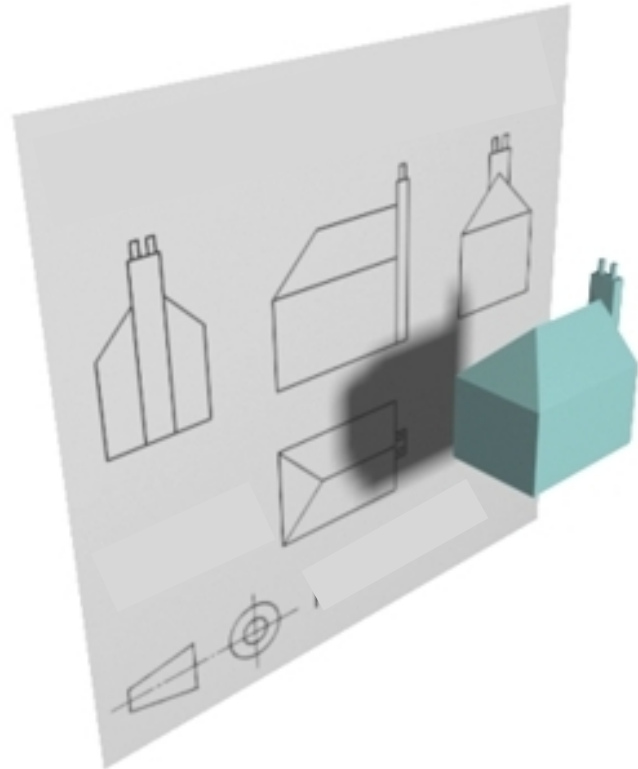

Taispeántar thíos trí chló de rud.

- (a) (2) Ainmnigh gach cló.  
(a) (3) Cuir isteach **DHÁ** thoise bhreise ar bith.

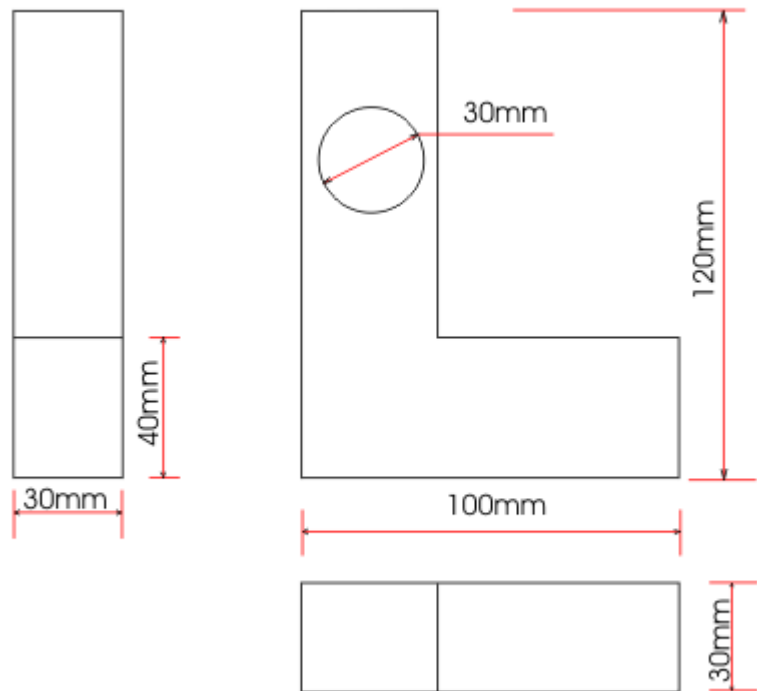

(b) Taispeánann an pictiúr cló isiméadrach d'fhoirgneamh.

Atarraing an cló isiméadrach den fhoirgneamh sa spás atá curtha ar fáil dó.

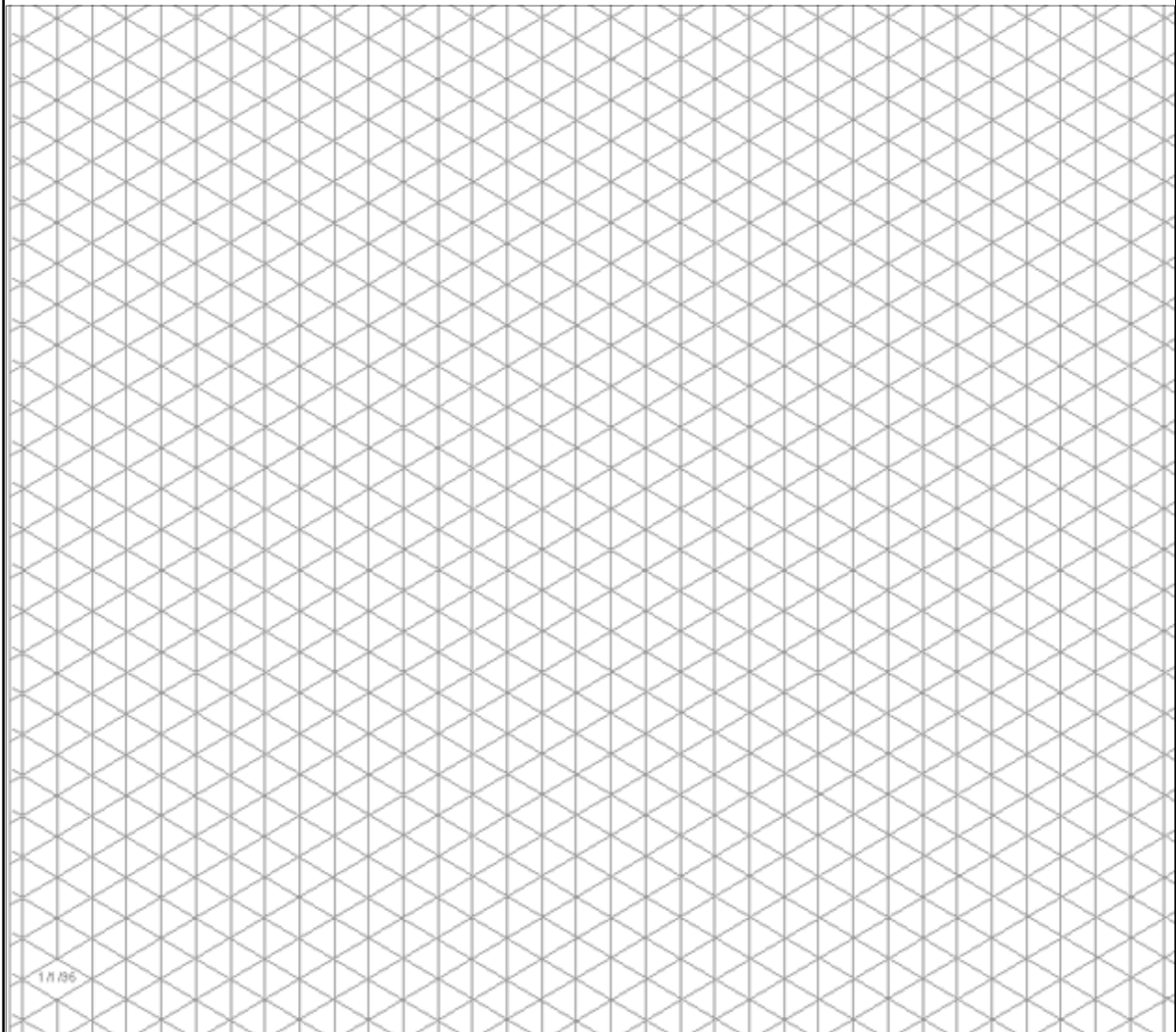
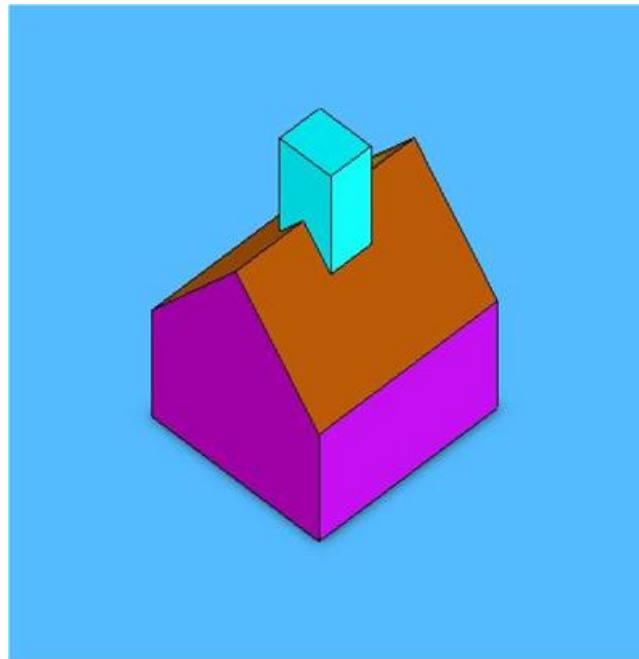



(c) Taispeántar thíos **cúig** lógó/comhartha atá bunaithe ar pholagáin.

Ainmnigh an polagán a úsáidtear chun gach lógó/comhartha a dhéanamh.

Lógó/Comhartha

Ainm an Pholagáin:

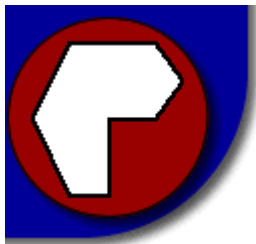

---

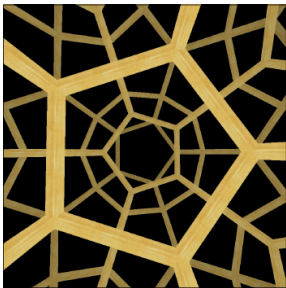

---

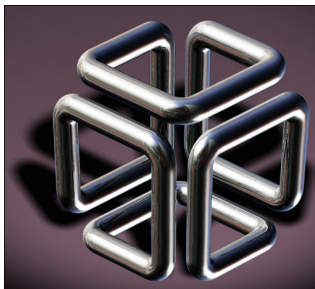

---



---



---

## Roinn 2

(135 Marc)

Freagair TRÍ CHEIST AR BITH sa roinn seo.

### 1. Tógáil

- (a) Aibhsíonn an póstaer a thaispeántar réamhchúraimí is ceart a chomhlíonadh maidir le sábháilteacht dóiteáin i scoil.

Mol **CÚIG** réamhchúram ba cheart a bheith san áireamh i bpóstaer dóiteáin dá leithéid don teach.

1. \_\_\_\_\_
2. \_\_\_\_\_
3. \_\_\_\_\_
4. \_\_\_\_\_
5. \_\_\_\_\_

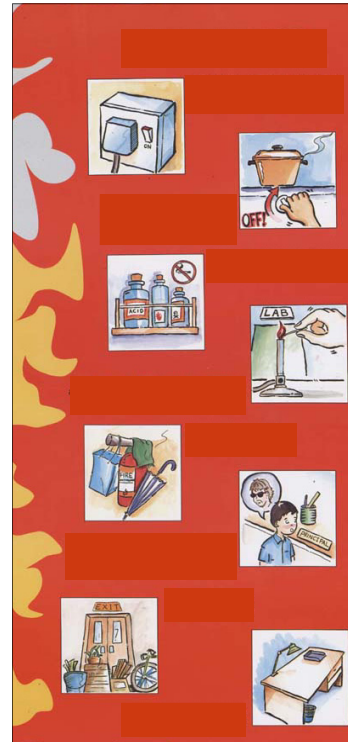



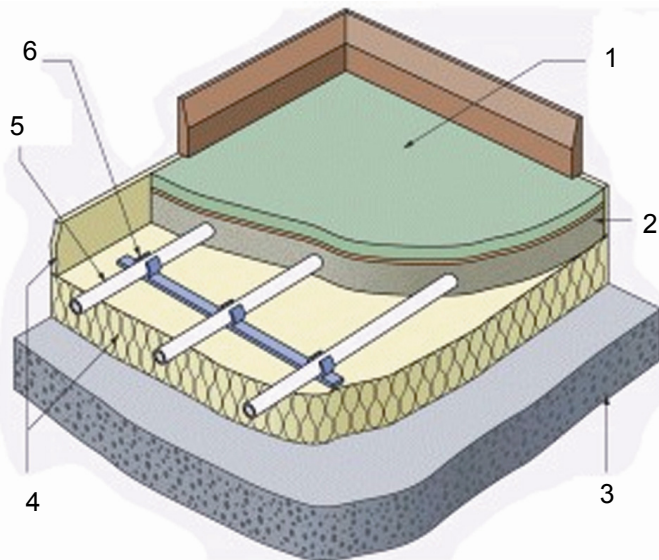

- (b) Taispeánann an léaráid sonraí tógála do théamh fo-urláir le haghaidh urlár na talún i dteach. Sainaithin **CÚIG** cinn ar bith de na sé pháirt a thaispeántar.

1. \_\_\_\_\_
2. \_\_\_\_\_
3. \_\_\_\_\_
4. \_\_\_\_\_
5. \_\_\_\_\_
6. \_\_\_\_\_

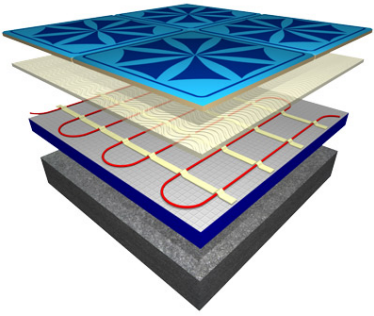
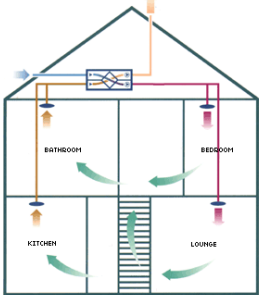

- (c) I ngeall ar chostas fuinnimh a bheith ag dul in airde, spreagtar daoine chun réitigh níos éifeachtaí fhuinnimh a úsáid nuair a bhíonn a dtithe á dtógáil. Taispeántar cúig chóras dhifriúla.  
Cuir tic le hais ainm an chórais a mheaitseálann gach íomhá i gceart.

	<p>Córais téimh fo-urláir</p> <p>Caidéil teasa gheoiteirmeacha</p> <p>Coirí adhmaid agus sliseanna adhmaid</p> <p>Córais ghrianphainéil</p> <p>Córais aerála aisghabhála teasa</p>
	<p>Córais téimh fo-urláir</p> <p>Caidéil teasa gheoiteirmeacha</p> <p>Coirí adhmaid agus sliseanna adhmaid</p> <p>Córais ghrianphainéil</p> <p>Córais aerála aisghabhála teasa</p>
	<p>Córais téimh fo-urláir</p> <p>Caidéil teasa gheoiteirmeacha</p> <p>Coirí adhmaid agus sliseanna adhmaid</p> <p>Córais ghrianphainéil</p> <p>Córais aerála aisghabhála teasa</p>
	<p>Córais téimh fo-urláir</p> <p>Caidéil teasa gheoiteirmeacha</p> <p>Coirí adhmaid agus sliseanna adhmaid</p> <p>Córais ghrianphainéil</p> <p>Córais aerála aisghabhála teasa</p>
	<p>Córais téimh fo-urláir</p> <p>Caidéil teasa gheoiteirmeacha</p> <p>Coirí adhmaid agus sliseanna adhmaid</p> <p>Córais ghrianphainéil</p> <p>Córais aerála aisghabhála teasa</p>

## 2. Seirbhísí Tógála

- (a) Is cuid chaighdeánach anois de na Rialacháin Tógála í rochtain le haghaidh daoine le míchumais.

Sainaithin **TRÍ** réimse sa teach inar gá rochtain do dhaoine míchumasaithe a chur san áireamh agus tabhair breac-chuntas ar na bearta is féidir a chur i bhfeidhm chun rochtain a dhéanamh níos éasca do dhaoine le míchumais.



1. \_\_\_\_\_

\_\_\_\_\_

\_\_\_\_\_

\_\_\_\_\_

\_\_\_\_\_

2. \_\_\_\_\_

\_\_\_\_\_

\_\_\_\_\_

\_\_\_\_\_

\_\_\_\_\_

3. \_\_\_\_\_

\_\_\_\_\_

\_\_\_\_\_

\_\_\_\_\_

\_\_\_\_\_

(b) Is fuinneamh malartach é grianfhuinneamh atá in úsáid go coitianta.

(b) (1) Liostaigh **DHÁ** bhuntáiste a bhaineann le grianfhuinneamh.

1. \_\_\_\_\_

2. \_\_\_\_\_

(b) (2) Liostaigh **DHÁ** mhíbhuntáiste a bhaineann le grianfhuinneamh.

1. \_\_\_\_\_

2. \_\_\_\_\_

(b) (3) Ainmnigh **DHÁ** bhreosla iontaise a úsáidtear chun leictreachas a tháirgeadh in Éirinn.

1. \_\_\_\_\_

2. \_\_\_\_\_

(c) Taispeánann an íomhá roinnt foinsí truaillithe uisce.

Sainaithin agus mínigh **TRÍ** fheabhsúchán a d'fhéadfadh an tionsclaíocht agus an talmhaíocht a dhéanamh chun truailliú uisce a laghdú nó chun deireadh a chur leis.

\_\_\_\_\_

\_\_\_\_\_

\_\_\_\_\_

\_\_\_\_\_

\_\_\_\_\_

\_\_\_\_\_

\_\_\_\_\_

\_\_\_\_\_

\_\_\_\_\_

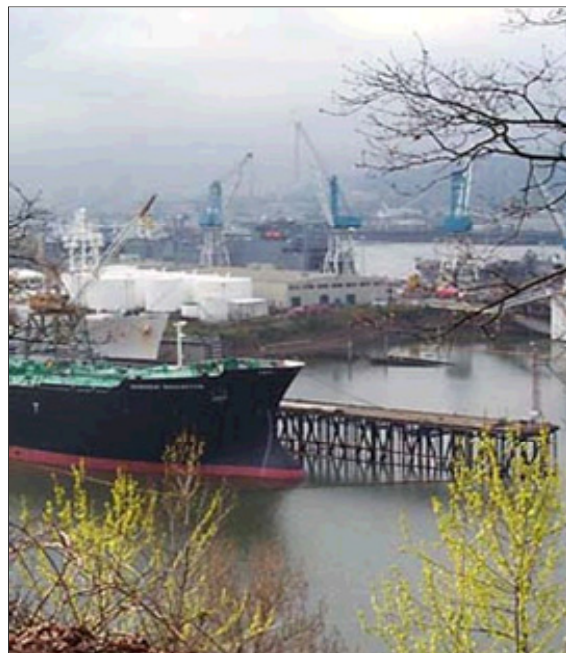

\_\_\_\_\_

\_\_\_\_\_

\_\_\_\_\_

\_\_\_\_\_

### 3. Ceardaíocht Adhmaid

- (a) Taispeánann an pictiúr raca ciorclach chun CDanna a stóráil. Déan cur síos gearr ar conas a dhéanfá bonn an raca a mharcáil amach agus a dhéanamh.



---



---



---



---



---



---



---



---







---



---

- (b) Taispeánann an tábla thíos cúig chlár adhmaid mhonaraithe. Ainmnigh gach ceann de na cláir mhonaraithe a thaispeántar agus mol úsáid do gach ceann díobh.

Clár Monaraithe					
Ainm:					
Úsáid:					



(c) Ainmnigh gach ceann de na **CÚIG** uirlis láimhe **DÉAG** a thaispeántar thíos.

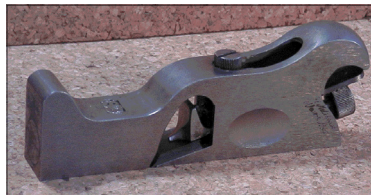
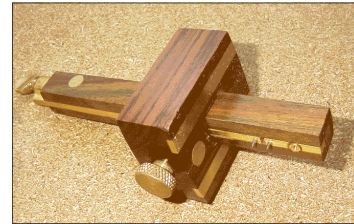
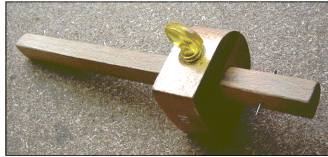

#### 4. Dearadh agus Déantús Bréagán Oideachasúil

- (a) (1) Déan cur síos, le cabhair sceitsí, ar bhréagán a rinne tú i modúl na mbréagán oideachasúil.



- (a) (2) Liostaigh **TRÍ** ghné oideachasúla den bhréagán.

1. \_\_\_\_\_

2. \_\_\_\_\_

3. \_\_\_\_\_

- (a) (3) Déan plé ar cén fáth a mbaineann tábhacht le tosca **Sláinte agus Sábháilteachta** i ndearadh agus i ndéantús bréagán oideachasúil.

---

---

---

---

---

---

---



(b) Taispeántar bád bréagáin maraon le feiste chun é a thiomáint tríd an uisce.

(b) (1) Mol **DHÁ** ábhar oiriúnacha don bhréagán seo.

1. \_\_\_\_\_

2. \_\_\_\_\_

(b) (2) Déan cur síos ar conas a dhéanfa an mheicníocht le cur ar chumas an bháid gluaiseacht san uisce.

\_\_\_\_\_

\_\_\_\_\_

\_\_\_\_\_

\_\_\_\_\_



(c) Taispeántar bréagán adhmaid.

(c) (1) Bain úsáid as nótaí agus sceitsí agus déan cur síos ar conas a ghearrfa amach próifíl an éisc.



\_\_\_\_\_

\_\_\_\_\_

\_\_\_\_\_

(c) (2) Liostaigh **DHÁ** réamhchúram ba cheart duit a chomhlíonadh nuair a bhíonn an bréagán seo á dhéanamh agat.

1. \_\_\_\_\_

\_\_\_\_\_

2. \_\_\_\_\_

\_\_\_\_\_

## 5. Dearadh Ríomhchuidithe

- (a) Baintear úsáid as comhordanáidí coibhneasta nuair a bhíonn pacáiste CAD á úsáid. Tarraing fíor agus úsáid á baint agat as na comhordanáidí a thugtar, ag tosú ó phointe A.



O phointe A

Go pointe: @30,30

Go pointe: @-20,0

Go pointe: @0,30

Go pointe: @-20,0

Go point: @0,-30

Go pointe: @-20,0

Go pointe: @30,-30.

Pointe A +

- (b) (1) Ainmnigh na horduithe **DRAW** (tarraing) a úsáidtear chun na rudaí a thaispeántar thíos a chruthú.

		AutoCAD		

- (b) (2) Ainmnigh na horduithe **MODIFY** (mionathraigh) a úsáidtear chun an rud ar clé a athrú s(n)a rud(aí) ar dheis.

- (c) Baintear úsáid as CÚIG chéim chun aonad taisceadáin a tharraingt agus pacáiste CAD á úsáid mar a thaispeántar sa tábla. Sainaithin na **CÚIG** ordú CAD a úsáidtear de réir mar a théann an sceitse ar aghaidh trí gach céim.

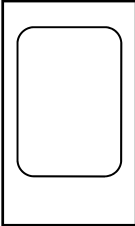
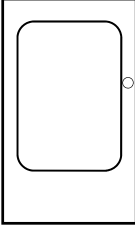
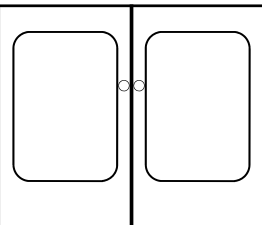
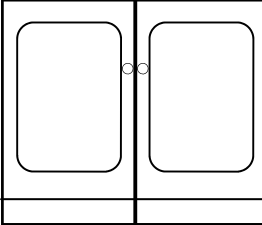
	Líníocht	Ordú CAD
1.		
2.		
3.		
4.		
5.		

# Leathanach Bán