



Coimisiún na Scrúduithe Stáit State Examinations Commission

Leaving Certificate Applied, 2012

Vocational Specialism – Engineering (240 marks)

Monday, 11 June

Morning 9:30 – 11:00

General Directions to Candidates

1. Write your **examination number** in this space.
2. Answer **all** questions from Section 1.
3. Answer **any three** questions from Section 2.
4. Write your answers in the spaces provided and include sketches as appropriate.
5. Hand up this paper at the end of the examination.
6. If Question 7 is attempted, answer **any two** topics.

<i>For the Superintendent only</i>	<i>For the Examiner only</i>	
<i>Centre Stamp</i>	1. Total of end of page totals	
	2. Aggregate total of all disallowed questions	
	3. Total mark awarded (1 minus 2)	
	4. Bonus mark for answering through Irish (if applicable)	
	5. Total mark awarded if Irish bonus applies (3 plus 4)	
	Note: The mark in row 3 (or row 5 if Irish bonus is awarded) must equal the total mark at the end of the script.	





Section 1 (90 Marks)

Answer **all three** questions

Section 1 Q1.

45 marks

Give brief answers to **any fifteen** of the following:
(Sketches may be used to explain your answers.)

QUESTION	ANSWER
<p>(a) Identify the joining process shown and give a practical example of where it could be used.</p> 	<p>Joining process _____</p> <p>Use _____</p> <p>_____</p>
<p>(b) Name the tool shown and state one use for it.</p> 	<p>Name _____</p> <p>Use _____</p> <p>_____</p>
<p>(c) State a suitable material to make the car exhaust shown.</p> 	<p>Name of material _____</p> <p>_____</p>
<p>(d) Identify the engineering component shown and state one use for it.</p> 	<p>Name _____</p> <p>Use _____</p> <p>_____</p>
<p>(e) Name the finishing process shown.</p> 	<p>Name of process _____</p> <p>_____</p> <p>_____</p>

QUESTION

ANSWER

(f) Gear A is moving in the direction shown. Tick the correct box to show the direction of gear B.

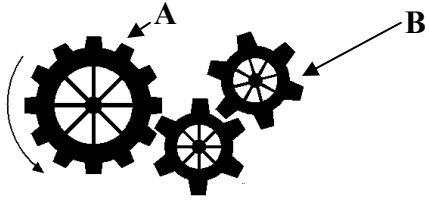

Tick the correct box to show the direction of Gear B.

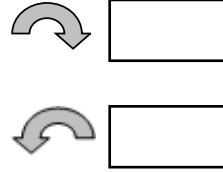

(g) Identify the special bolt shown and give **one** advantage of using this type of bolt.



Name _____

Advantage _____

(h) Name the washer shown and give a suitable use for it.



Name _____

Use _____

(i) Suggest a suitable material that could be used to manufacture the roll cage marked A, in the rally car shown opposite.



Suitable material

(j) Tick the correct box to indicate the two metals used to make the alloy solder, shown opposite.



Lead and Tin

Copper and Zinc

Copper and Tin

QUESTION	ANSWER
----------	--------

(k) Name the tool shown opposite and state **one** use for it in the Engineering room.



Tool _____

Use _____

(l) Please tick the correct box to show the most suitable type of metal used to make the *plumbing fitting* marked A.



Brass

Aluminium

(m) Identify the filing technique shown.



Filing technique _____

(n) Name the tools marked A and B below.

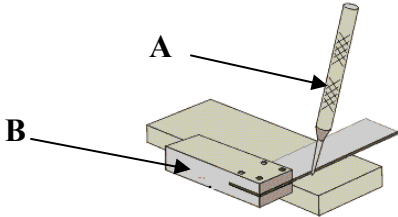

Name of tool A _____

Name of tool B _____

(o) Identify the screw shown and state a suitable use for it.



Name of screw _____

Use _____

QUESTION	ANSWER
----------	--------

(p) Choose a suitable material for the casing of the laptop computer shown and give a reason for your choice of material.



Suitable material _____
Reason _____

(q) Name and give a use for the tool shown below.



Name of tool _____
Use _____

(r) State a use for the item shown below.

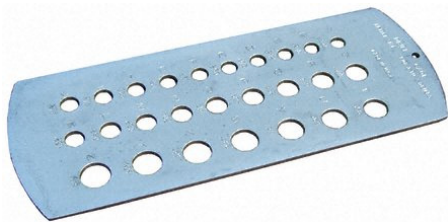

Use _____

(s) Identify the turning process shown below.

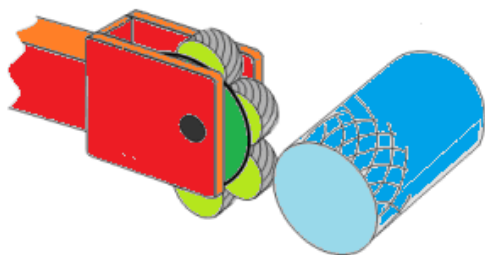

Name of process _____

(t) Identify the mechanism marked **A** and suggest a suitable material for part **B**.

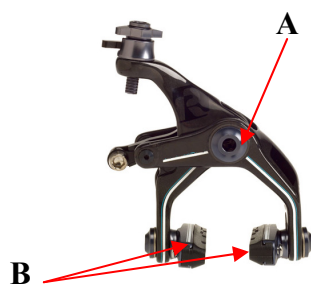

Name of mechanism **A** _____

Material for **B** _____

A pictorial view of a docking station for a personal music player is shown below. Draw the following **two** views of the docking station on the grid paper opposite:

- (a) A front elevation in the direction of arrow A.
- (b) A plan projected from view (a).

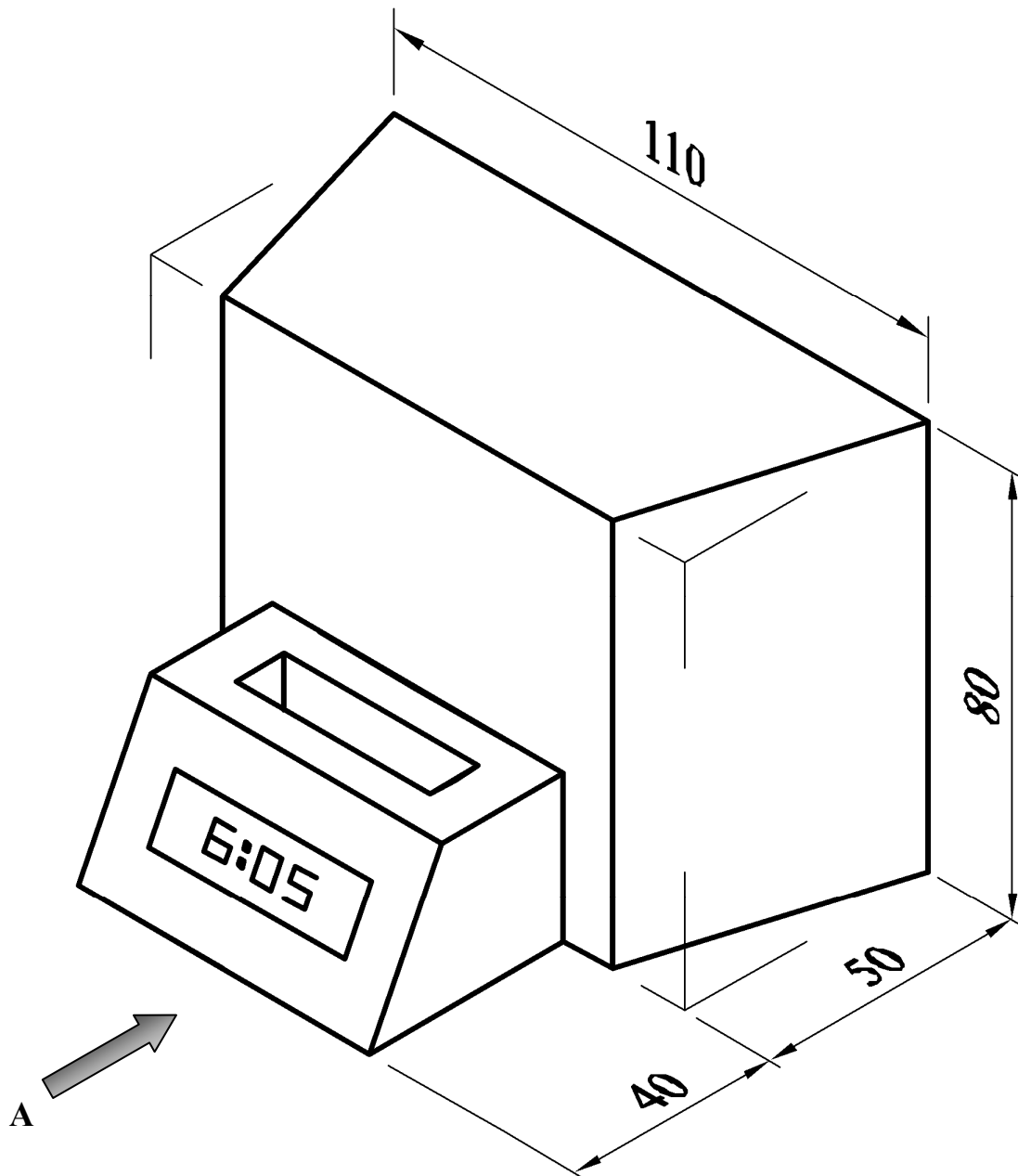

Note: Each grid square represents 5 mm

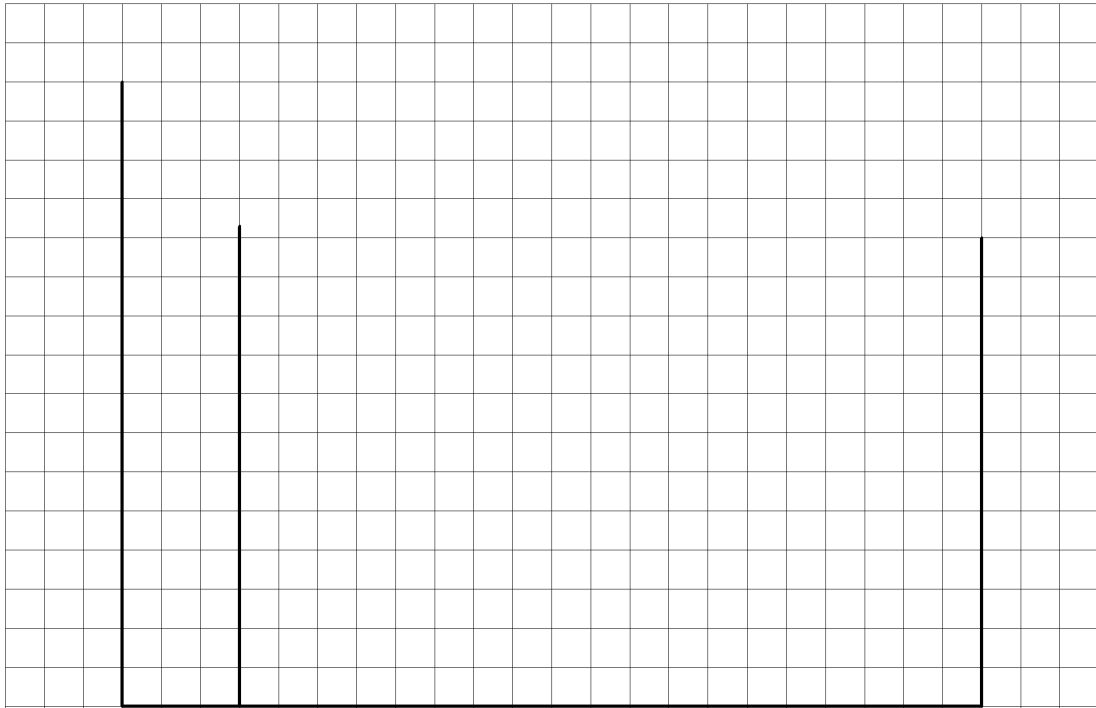

Complete the Elevation

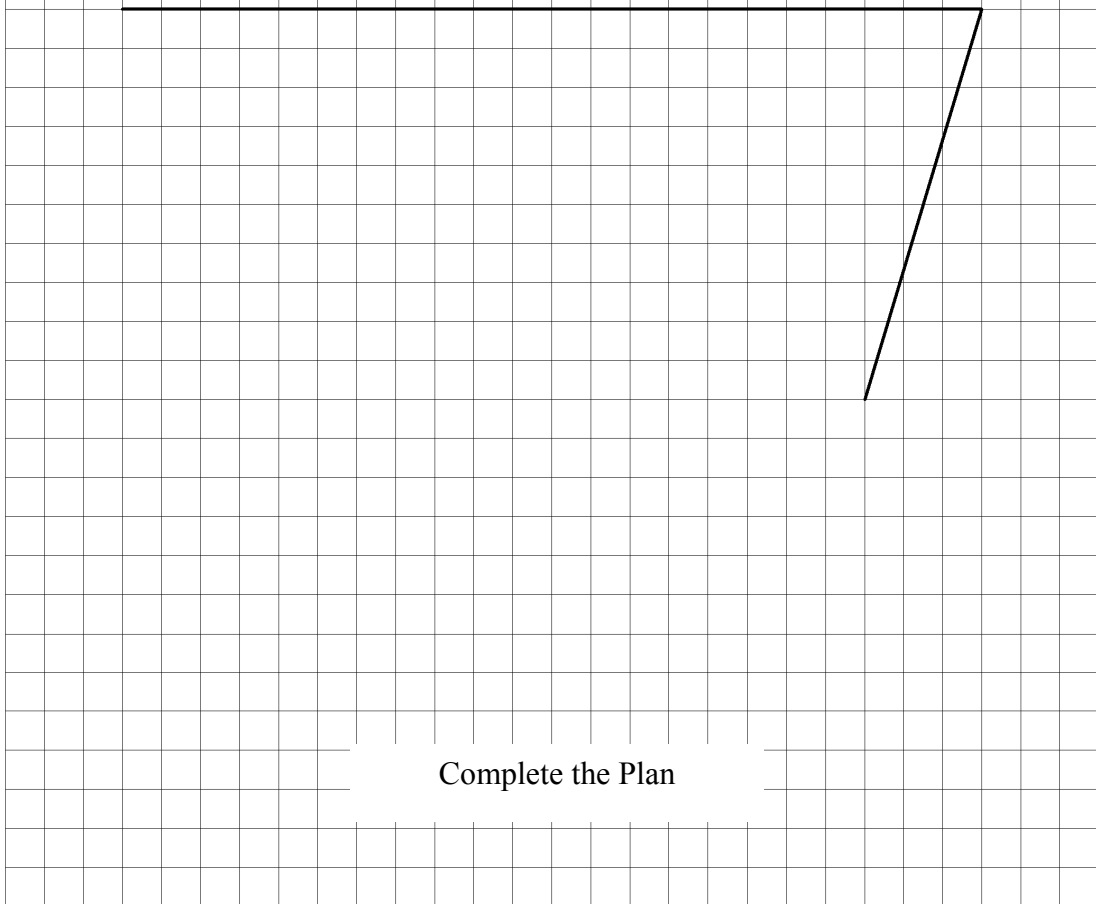

Complete the Plan

- (a) Name the **two** pieces of engineering equipment shown at **A** and **B** below.
 State **two** safety precautions that should be observed when using **each** piece of equipment.

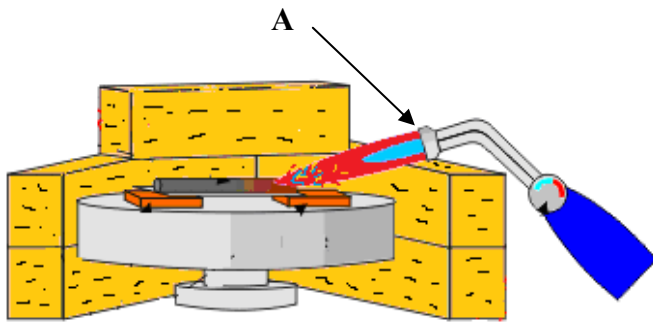

B



A - Name of engineering equipment

Safety Precaution 1

Safety Precaution 2

B - Name of engineering equipment

Safety Precaution 1

Safety Precaution 2

- (b) The diagram shows a dot punch and hammer being used to mark out a metal piece.
 Identify **two** safety precautions that should be observed by students when marking out.

Safety Precaution 1 _____

Safety Precaution 2 _____



(c) Describe **any two** safety features on the drilling machine shown.

Safety Feature 1 _____

Safety Feature 2 _____

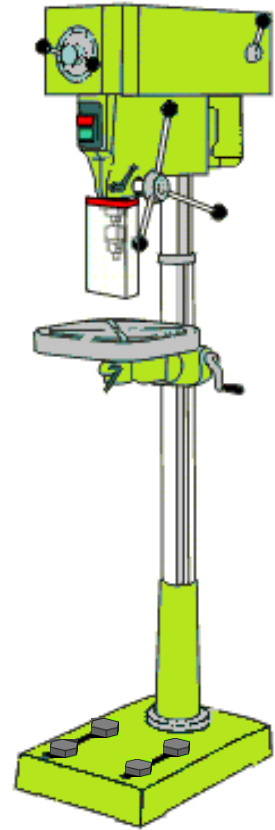

(d) State **one** safety precaution that should be observed when using the electric power hacksaw shown.



(e) The safety symbols below may be found in an Engineering room. Give a brief explanation for **each** of the symbols shown.

A



Symbol A _____

B



Symbol B _____

A sketch of the **final solution** for the tailgate should be drawn below in **Grid B**.

Grid B – FINAL SOLUTION

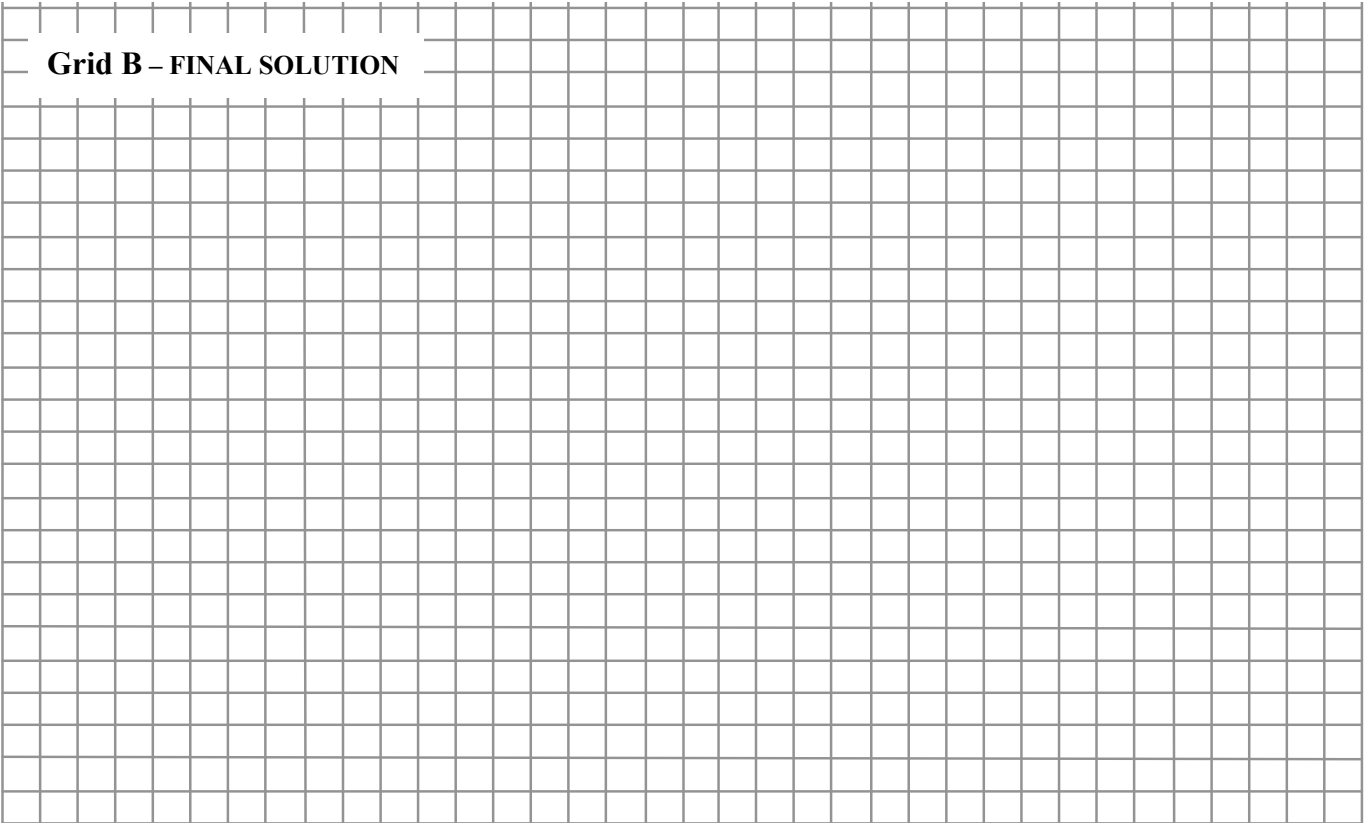

(b)

(i) Suggest a suitable material for manufacturing the frame of the airport luggage trolley shown.

(ii) Give a reason for your choice of material.

(iii) Suggest **one** suitable improvement that could be considered in the design of the trolley shown.



- (a) A cross sectional diagram of a two-stroke engine is shown below. Identify and describe the function of **each** of the labelled parts, **P**, **Q**, **R** and **S**.

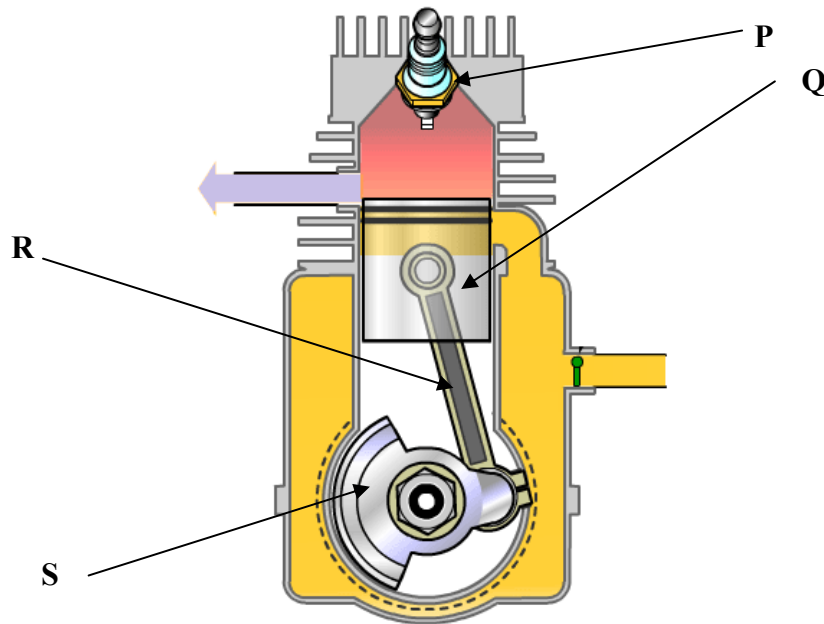

Part	Name of Part	Function
P		
Q		
R		
S		

(b) Identify the part shown in the diagram opposite and state the function of this part in a car engine.

Name _____

Function _____

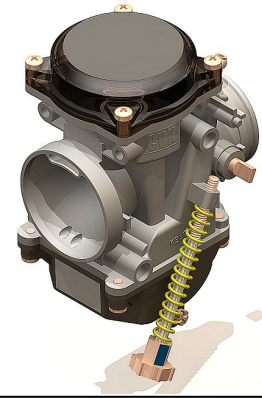

(c) Some important parts of a car engine are shown below. Identify the parts labelled U, V, W and X and state the function of each.



Part	Name of Part	Function
U		
V		
W		
X		

(b) The copper bowl labelled **A** is made using the following equipment and tools labelled **B** and **C** below. Briefly describe, in the spaces below, any **four** key stages used to produce the copper bowl.
(Use sketches as appropriate.)

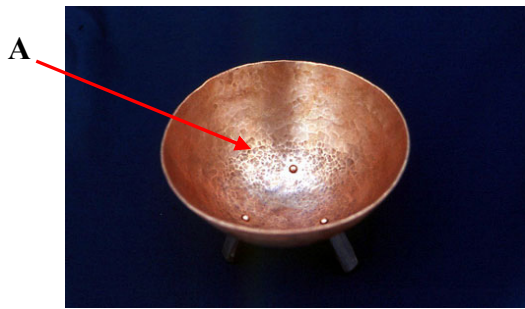

Stage 1 _____

Stage 2 _____

Stage 3 _____

Stage 4 _____

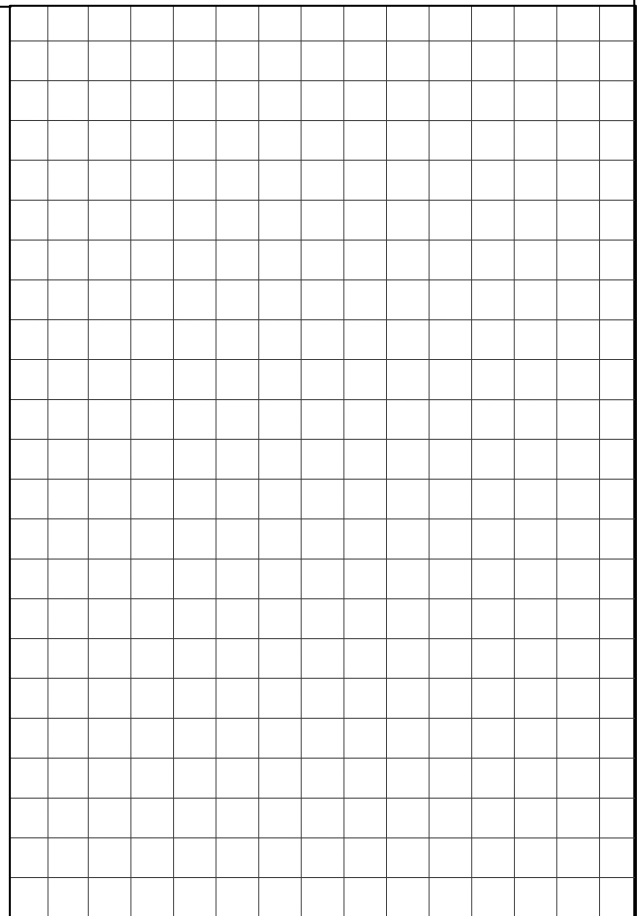

(c) State **two** safety precautions to be observed during the hollowing process.

Precaution 1 _____

Precaution 2 _____

Systems Module

(Any **two** topics comprise a full module.)

Answer **any two** from the following five topics.

Topic (a) – Computer Aided Design (CAD)

Topic (b) – Electricity

Topic (c) – Electronics

Topic (d) – Mechanisms

Topic (e) – Pneumatics

(a) A CAD drawing of a machine guide is shown below. List **any four** CAD commands necessary to produce the drawing below.

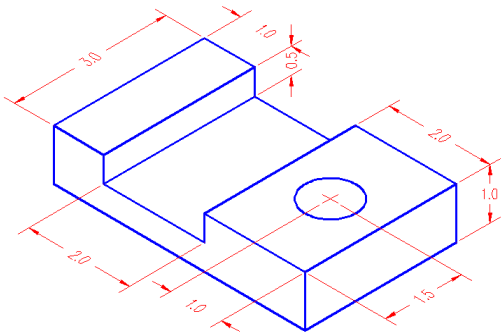

Command 1 _____

Command 2 _____

Command 3 _____

Command 4 _____

(b) Give **two** advantages of using CAD drawings over traditional pencil drawings.

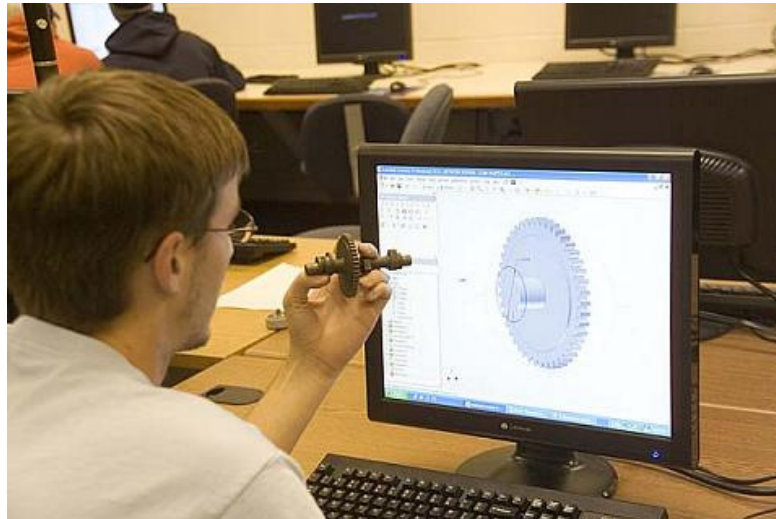

Advantage 1 _____

Advantage 2 _____

(a) Identify, in the spaces provided, the components of the three-pin plug shown below.

Part	Name
A	
B	
C	
D	
E	

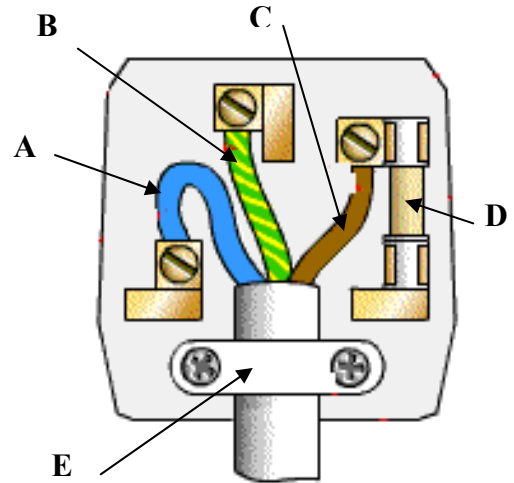

(b) Identify the electrical component shown below and give a use for it.



Name of Component _____

Use _____

(c) Name and state a suitable use for **each** of the components shown below.



Name _____

Use _____



Name _____

Use _____



Name _____

Use _____

(a) Name and state a suitable use for **each** of the components shown below.

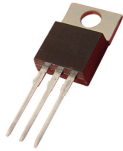

Name _____

Use _____

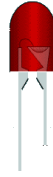

Name _____

Use _____



Name _____

Use _____

(b) Identify the electronic component shown and explain its function.

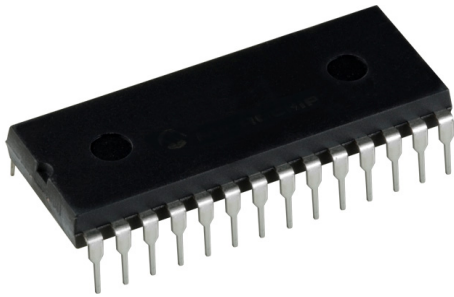

Name _____

Function _____

(c) An electronic toy car is shown below. Describe briefly, in the space provided, how the toy car works.

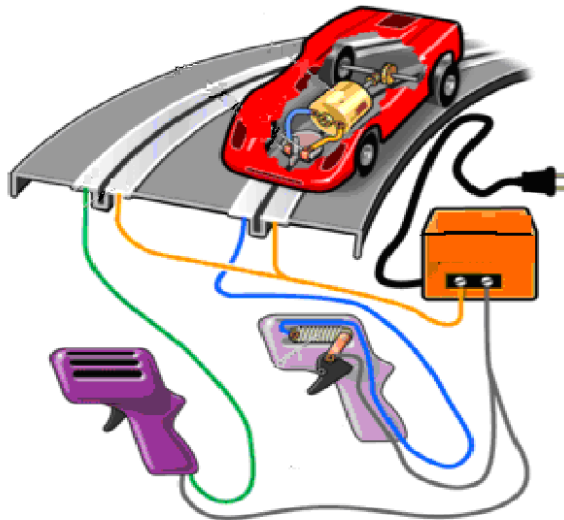

Description _____

- (a) The diagram below shows a mechanism to operate a pull-along toy. Explain how the mechanism works.

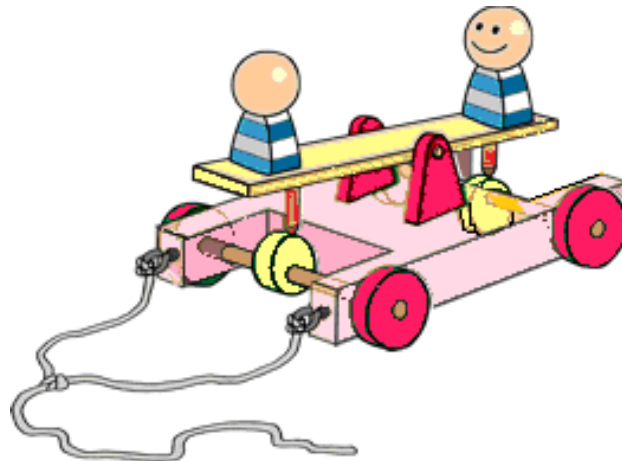

Explanation _____

- (b) Identify the **three** mechanisms A, B and C shown below and state **one** use of each.

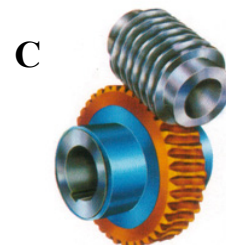
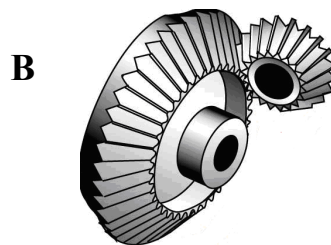
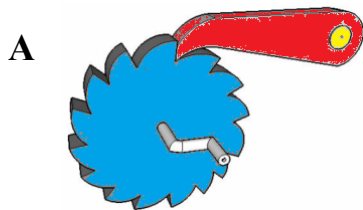

	Name	Use
Mechanism A		
Mechanism B		
Mechanism C		

(a) Identify the pneumatic components below and state the function of each.

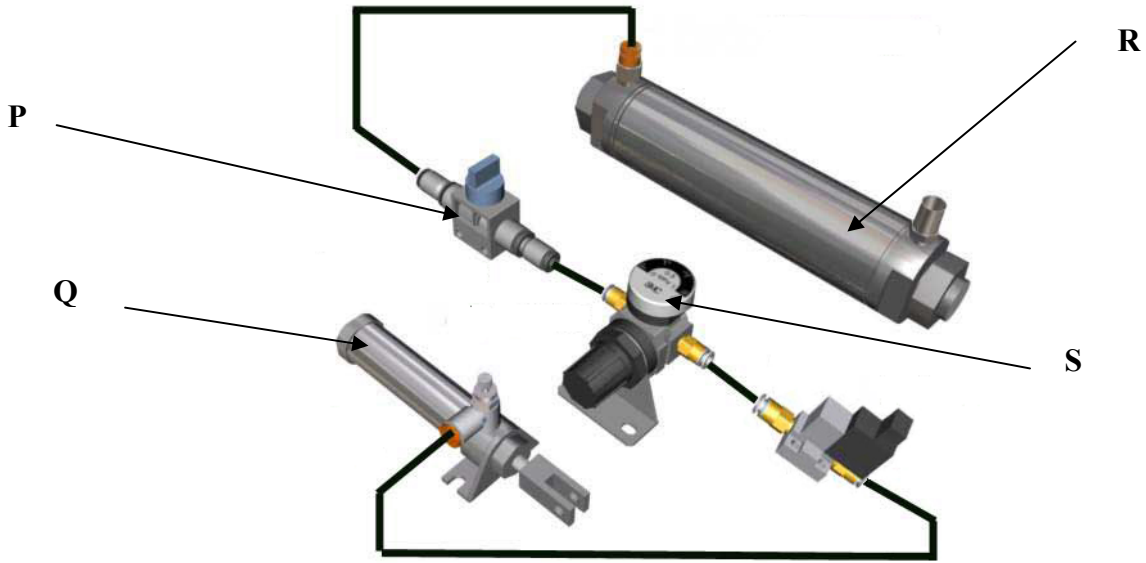

	Name	Function
P		
Q		
R		
S		

(b) Pneumatic systems require safe work practices. Identify the component below and state the safety function it has in a pneumatic circuit.

Name of Component _____

Safety Function _____



Blank Page

For Examiners use only		
Question	Mark	Total
Section 1		
1		
2		
3		
Section 2		
4		
5		
6		
7 (a)		
7 (b)		
7 (c)		
7 (d)		
7 (e)		
Total		

Blank Page