



# Coimisiún na Scrúduithe Stáit State Examinations Commission

*Leaving Certificate Applied, 2007*

## Vocational Specialism – Engineering (240 marks)

Monday 11<sup>th</sup> June, 2007

Morning 9.30 a.m. – 11.00 a.m.

### *General Directions to Candidates*

1. Write your **examination number** in this space.
2. Answer **all** questions from Section 1.
3. Answer **any three** questions from Section 2.
4. Write your answers in the spaces provided and include sketches as appropriate.
5. Hand up this paper at the end of the examination.
6. If you attempt Question 7, answer any two topics.

<i>For the Superintendent only</i>	<i>For the Examiner only</i>	
<i>Centre Stamp</i>	1. Total of end of page totals	
	2. Aggregate total of all disallowed questions	
	3. Total mark awarded (1 minus 2)	
	4. Bonus mark for answering through Irish (if applicable)	
	5. Total mark awarded if Irish bonus (3 plus 4)	
	Note: The mark in row 3 (or row 5 if Irish bonus is awarded) must equal the total mark on the flap at the end of the script.	





# Section 1 (90 Marks)

Answer **all three** questions

Section 1 Q1.

45 marks

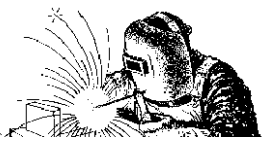
Give brief answers to **any fifteen** of the following:  
(sketches may be used to explain your answers).

QUESTION	ANSWER
<p>(a) What is the purpose of the spring dividers shown here?</p> 	<p>Purpose _____</p> <p>_____</p> <p>_____</p>
<p>(b) State <b>one</b> safety precaution to be observed when using an electric hand drill.</p> 	<p>Safety precaution _____</p> <p>_____</p> <p>_____</p>
<p>(c) Give <b>one</b> reason for using a welding mask, as shown.</p> 	<p>Reason _____</p> <p>_____</p>
<p>(d) Identify the tool shown and state its use.</p> 	<p>Tool _____</p> <p>Use _____</p> <p>_____</p>
<p>(e) Give <b>one</b> important reason why wheelie bins are made from plastic.</p> 	<p>Reason _____</p> <p>_____</p> <p>_____</p>

QUESTION

ANSWER

(f) Name the tool shown and state a suitable use for it.



Name \_\_\_\_\_

Use \_\_\_\_\_

\_\_\_\_\_

(g) Name **any two** of the fastener parts shown at A, B and C.

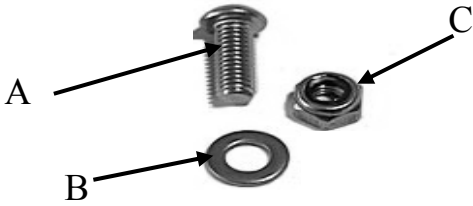

A \_\_\_\_\_

B \_\_\_\_\_

C \_\_\_\_\_

(h) Tick the correct box to indicate the two main metals used to make the brass door handle shown.

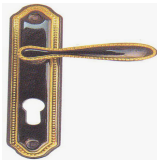

Lead + Iron

Copper + Zinc

Tin + Silver

(i) State **one** safety precaution to be observed when using the snips, as shown.



Safety precaution \_\_\_\_\_

\_\_\_\_\_

\_\_\_\_\_

(j) Name a suitable material used to make brake pads shown.



Brake pads

Material \_\_\_\_\_

\_\_\_\_\_

QUESTION	ANSWER
----------	--------

(k) Name a suitable material used to make the body of the mobile phone shown, and give **one** reason for your choice of material.



Material \_\_\_\_\_  
Reason \_\_\_\_\_  
\_\_\_\_\_

(l) State where this type of battery may be used.



Use \_\_\_\_\_  
\_\_\_\_\_

(m) Name **any two** parts of the hammer shown.

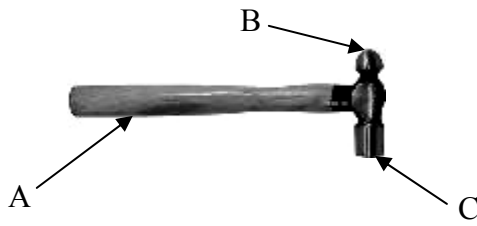

A \_\_\_\_\_  
B \_\_\_\_\_  
C \_\_\_\_\_

(n) Name the spanner shown and state a suitable use for it.



Name \_\_\_\_\_  
Use \_\_\_\_\_  
\_\_\_\_\_

(o) Name a suitable metal used to make the drill bit shown, and give **one** reason for your choice of metal.



Name of metal \_\_\_\_\_  
Reason \_\_\_\_\_  
\_\_\_\_\_

QUESTION	ANSWER
----------	--------

(p) Name the gauge shown and state its use.



Name \_\_\_\_\_

Use \_\_\_\_\_

\_\_\_\_\_

\_\_\_\_\_

(q) Give **one** reason why brass is used for the pins of the plug shown.

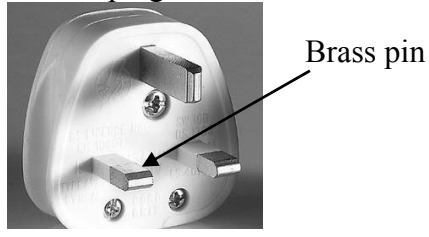

Reason \_\_\_\_\_

\_\_\_\_\_

\_\_\_\_\_

\_\_\_\_\_

(r) What does this safety symbol indicate and where it would be used?



This indicates \_\_\_\_\_

\_\_\_\_\_

Where used \_\_\_\_\_

\_\_\_\_\_

(s) Identify the tool shown and give a suitable use.



Name \_\_\_\_\_

Use \_\_\_\_\_

\_\_\_\_\_

\_\_\_\_\_

(t) Suggest **one** reason why cast iron is used in the manufacture of the engineer's vice shown.



Reason \_\_\_\_\_

\_\_\_\_\_

\_\_\_\_\_

A pictorial view of a digital camera is shown below.

Draw the following **two** views of the digital camera on the grid paper opposite:

- (a) A front elevation in the direction of arrow 'A'.
- (b) A plan projected from view (a).
- (c) One dimension is shown on the pictorial view. Insert **three** other dimensions on your drawing in the grid paper opposite.

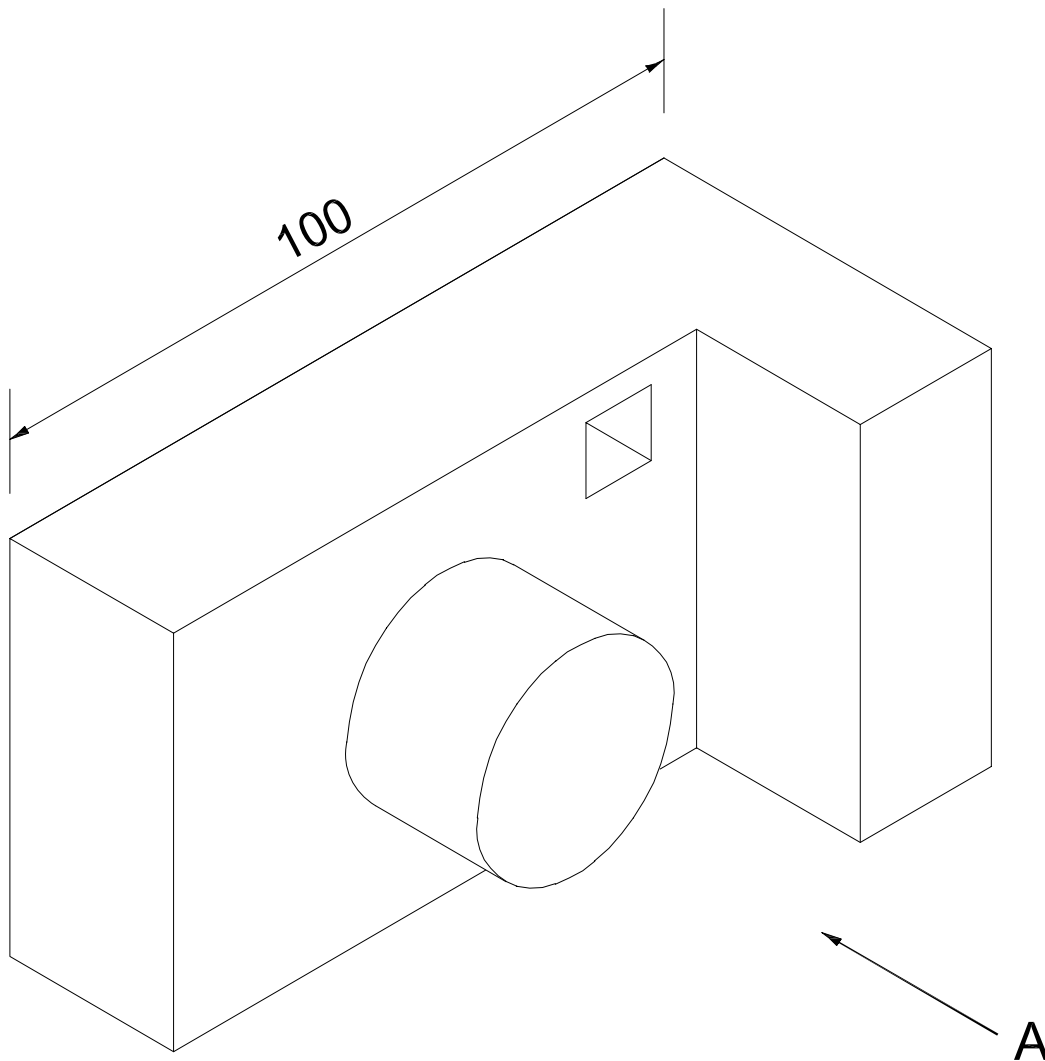

Note : Each grid-square is 5 mm long.

100

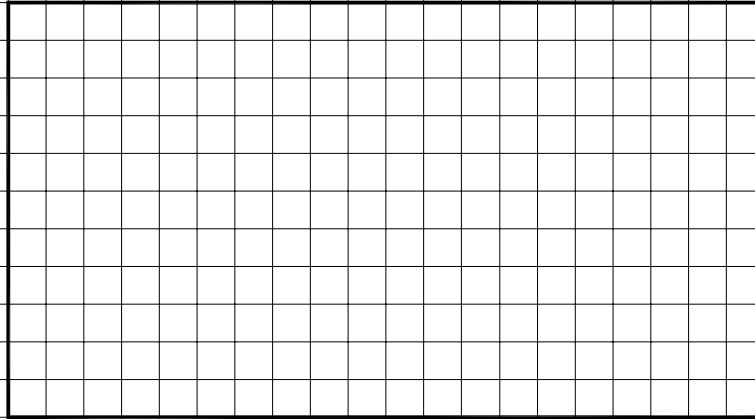

Complete the Elevation

Complete the Plan

(a) Name and give a suitable use for any **two** of the safety items shown below.

A



B



C



Name of safety item	Suitable use
A _____ _____	A _____ _____
B _____ _____	B _____ _____
C _____ _____	C _____ _____

(b) The diagram shows a drilling machine. State **two** safety precautions that should be observed when using a drilling machine.

Safety Precaution 1 \_\_\_\_\_

\_\_\_\_\_

Safety Precaution 2 \_\_\_\_\_

\_\_\_\_\_





(c) Identify **any two** dangers associated with the use of aerosol paints and describe the safety precautions that should be observed in each case.

Danger \_\_\_\_\_

\_\_\_\_\_

Safety precaution \_\_\_\_\_

\_\_\_\_\_

\_\_\_\_\_

Danger \_\_\_\_\_

\_\_\_\_\_

Safety precaution \_\_\_\_\_

\_\_\_\_\_

\_\_\_\_\_

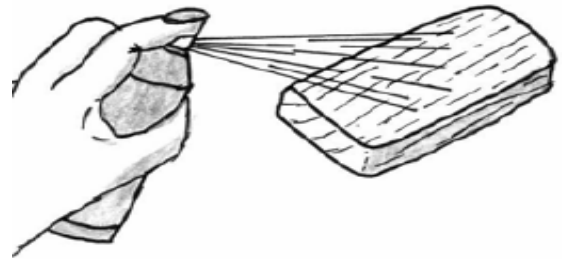

(d) State **one** safety precaution that should be observed when using a hacksaw to cut metal.

\_\_\_\_\_

\_\_\_\_\_

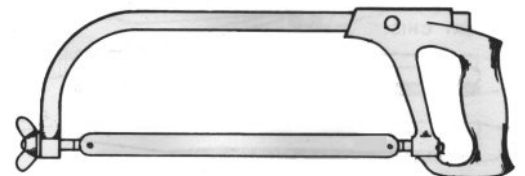

(e) The safety symbols shown below may be found in an engineering workshop. Give a brief explanation for **each** of the symbols shown.

A



Symbol A \_\_\_\_\_

\_\_\_\_\_

B



Symbol B \_\_\_\_\_

\_\_\_\_\_

*Section 2 (150 Marks)*  
Answer **any three** questions

*Section 2*    **Q4.**

**50 marks**

**(a)** Design, in the spaces provided, a suitable support bracket to enable the television shown to be mounted on a concrete wall.

The design should clearly show **each** of the following:

- (i)** a base support for the television;
- (ii)** how the bracket is to be secured to a concrete wall.

Draw in **Grid A** sketches of **different ideas** you considered for the support bracket.  
Draw in **Grid B** a sketch of the **final solution** for the support bracket.

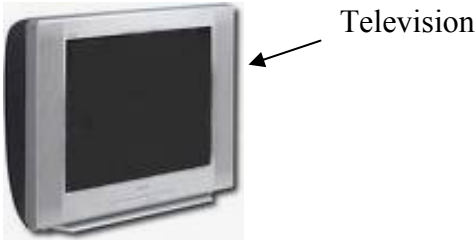

**Different ideas** for the support bracket should be drawn below in Grid A.

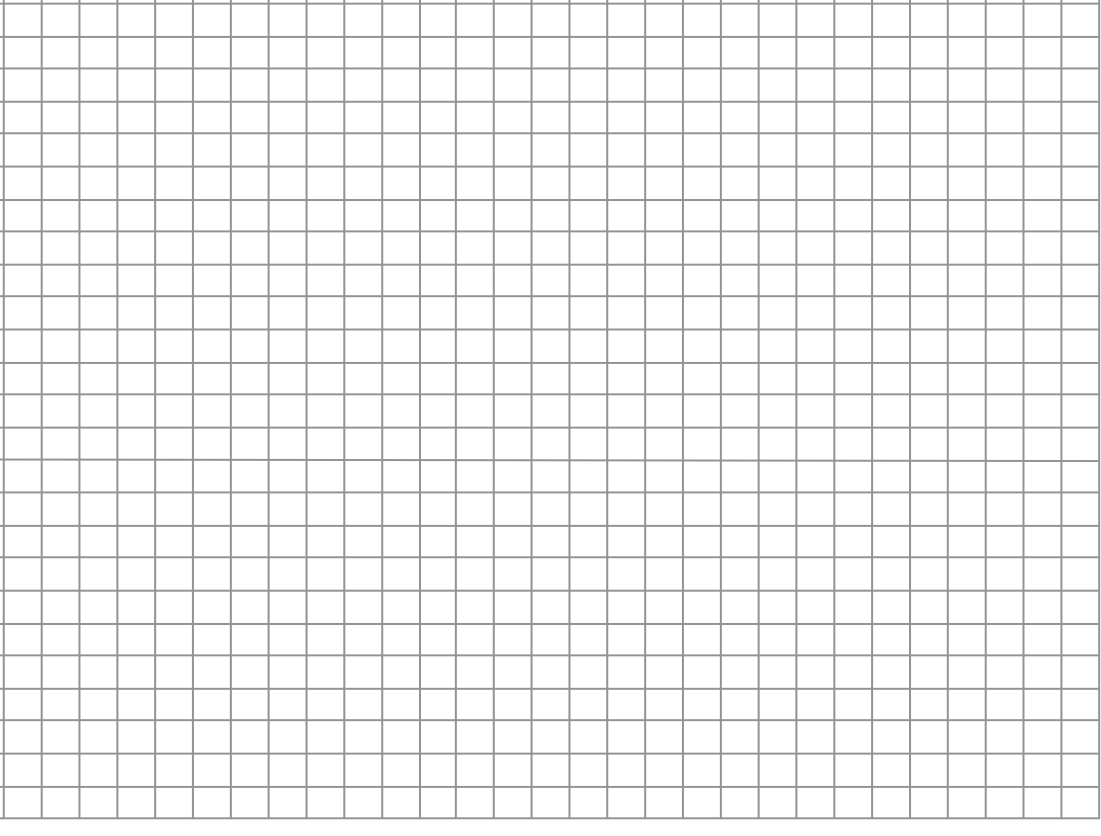
<b>Grid A - IDEAS</b>	
-----------------------	--

A sketch of the **final solution** for the support bracket should be drawn below in Grid B.

**Grid B - FINAL SOLUTION**

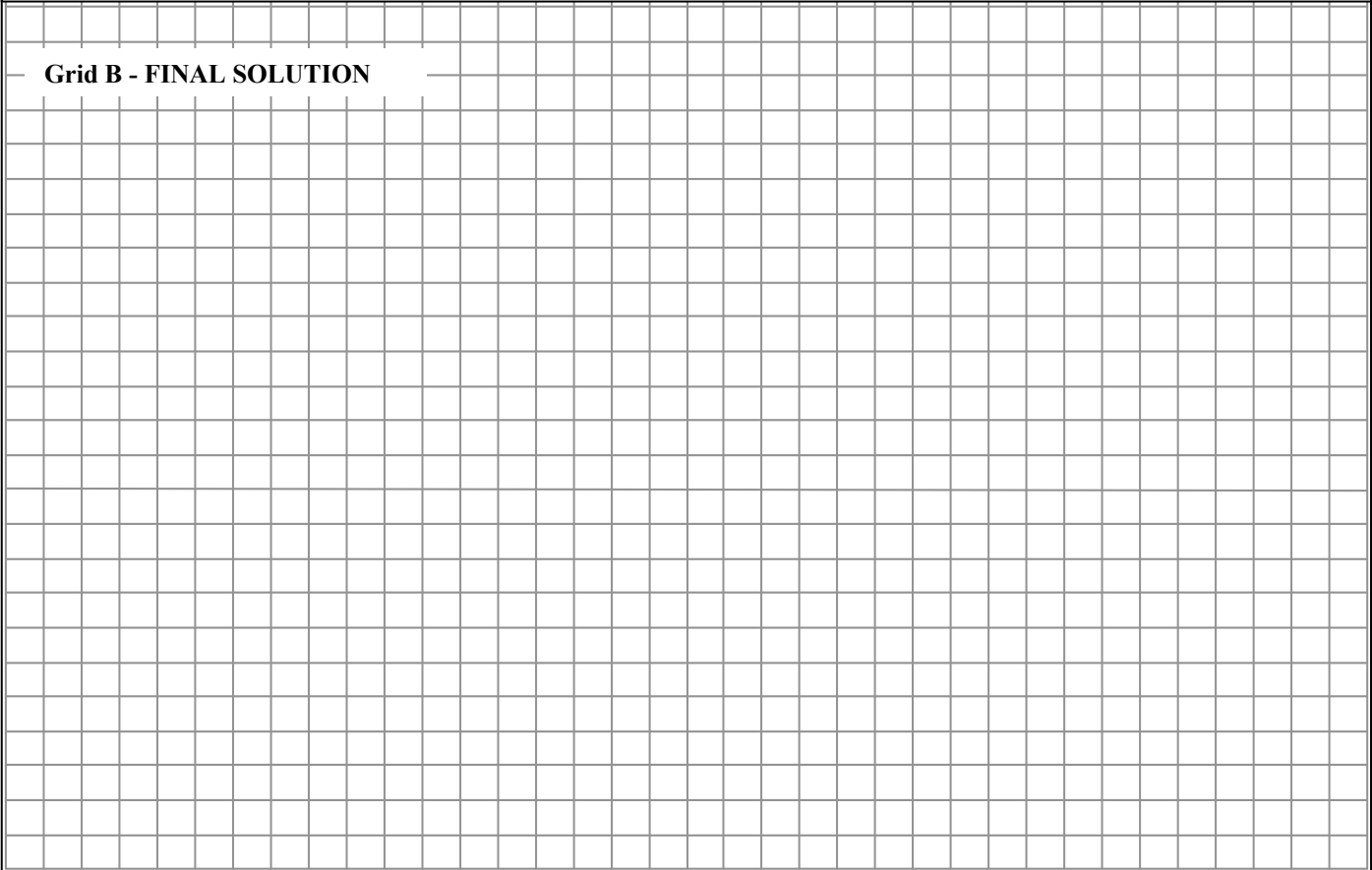

**(b)** You are required to make the notepad holder shown below.

**(i)** Suggest a suitable material for manufacturing the notepad holder.

\_\_\_\_\_

**(ii)** Give a reason for your choice of material.

\_\_\_\_\_

**(iii)** List **three** stages in the manufacturing process of the notepad holder based on your chosen material.

Stage 1 \_\_\_\_\_

Stage 2 \_\_\_\_\_

Stage 3 \_\_\_\_\_

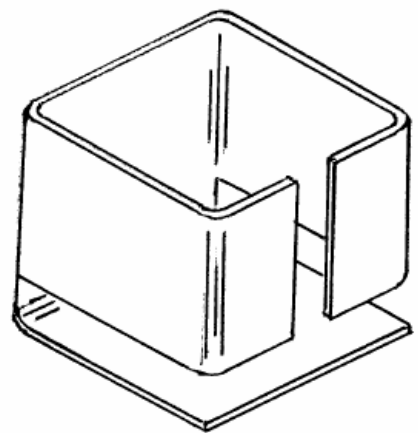

(a) A diagram of a two-stroke petrol engine, with the main parts labelled, is shown below.

Describe the function of **any three** of the labelled parts:

(i) Connecting Rod; (ii) Spark Plug; (iii) Piston; (iv) Crank.

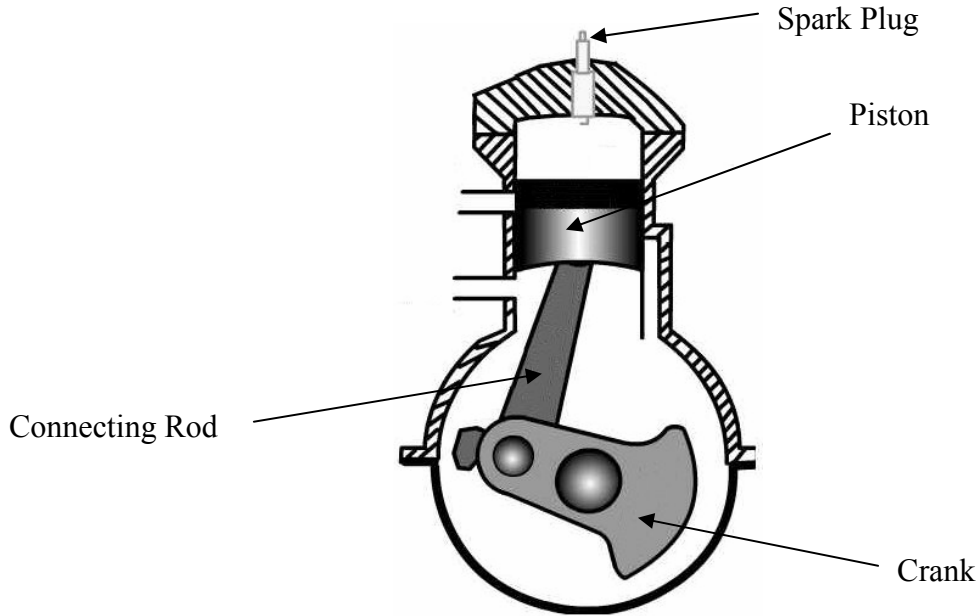

(i) Connecting Rod \_\_\_\_\_

\_\_\_\_\_

(ii) Spark Plug \_\_\_\_\_

\_\_\_\_\_

(iii) Piston \_\_\_\_\_

\_\_\_\_\_

(iv) Crank \_\_\_\_\_

\_\_\_\_\_

(b) Explain why it is necessary to use a mix of gasoline and oil (two-stroke oil) as fuel in a two-stroke engine.

---



---

(c) Give **one** disadvantage of a two-stroke engine compared with a four-stroke engine.

---

(d) Three common components used in a motor bike are labelled X, Y and Z. Identify the **three** components and explain the function of **each**.

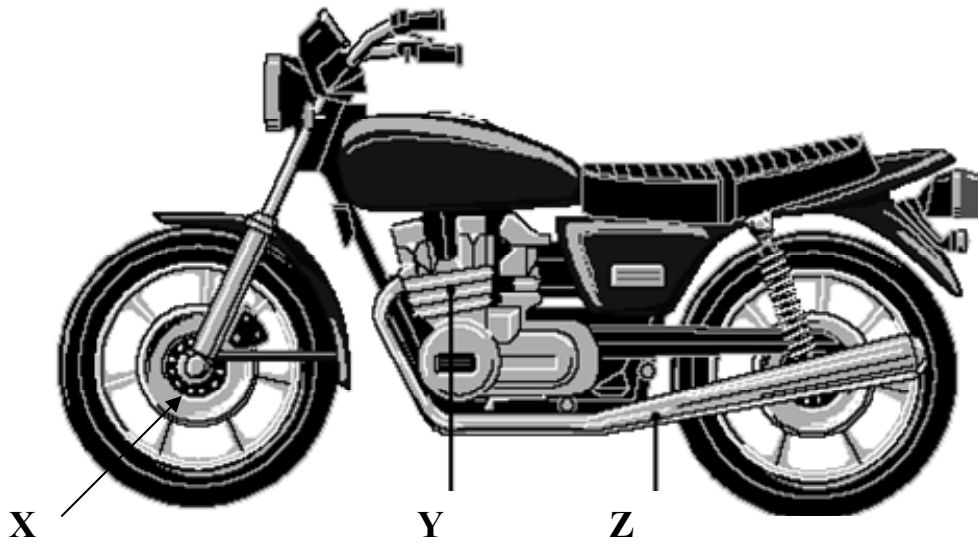

	Name of Component	Function
X		
Y		
Z		

(a) The bowl shown below is formed from a flat copper disk using a mallet and sandbag. Describe briefly **any four** key stages completed in the production of the bowl. (Use sketches as appropriate).

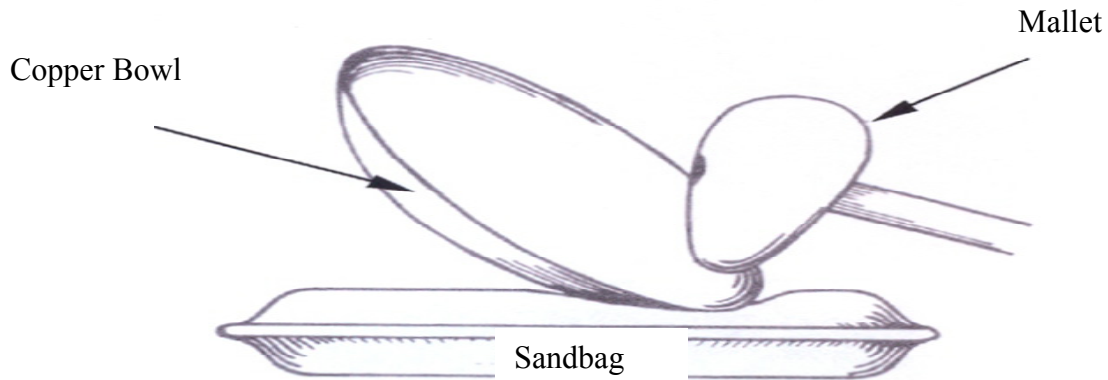

Stage 1 \_\_\_\_\_  
\_\_\_\_\_  
\_\_\_\_\_

Stage 2 \_\_\_\_\_  
\_\_\_\_\_  
\_\_\_\_\_

Stage 3 \_\_\_\_\_  
\_\_\_\_\_  
\_\_\_\_\_

Stage 4 \_\_\_\_\_  
\_\_\_\_\_  
\_\_\_\_\_

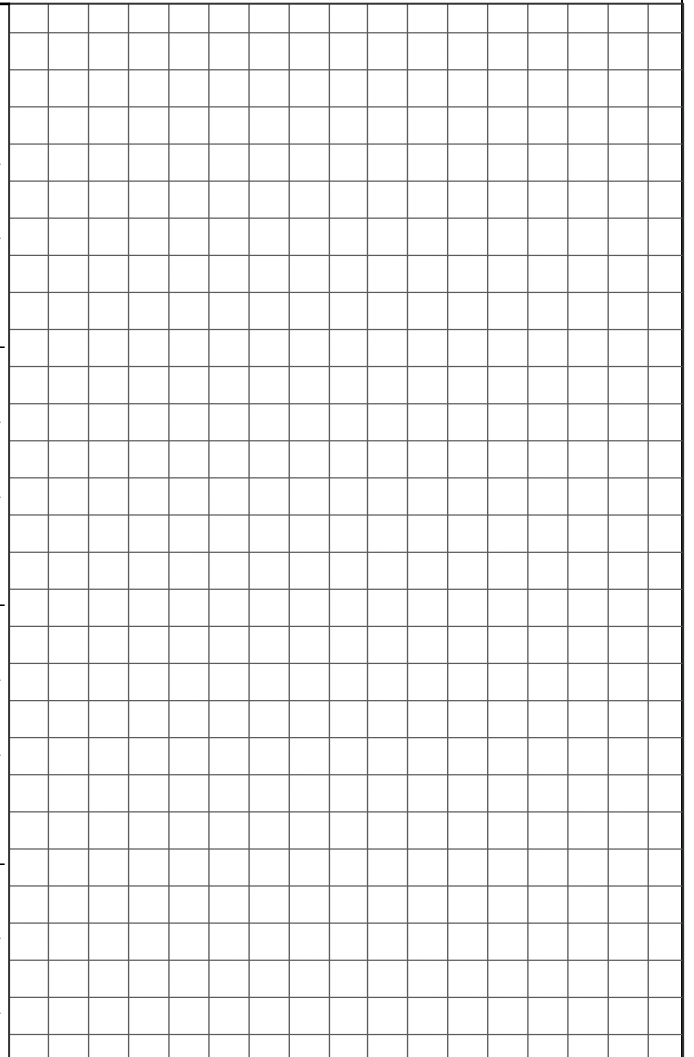



## **Systems Module**

(Any two topics comprise a full module)

Answer **any two** from the following five topics:

Topic (a) – Computer Aided Design (CAD)

Topic (b) – Electricity

Topic (c) – Electronics

Topic (d) – Mechanisms

Topic (e) – Pneumatics



- (a) A CAD drawing of a digital music player is shown. List **any four** CAD commands necessary to produce the drawing.

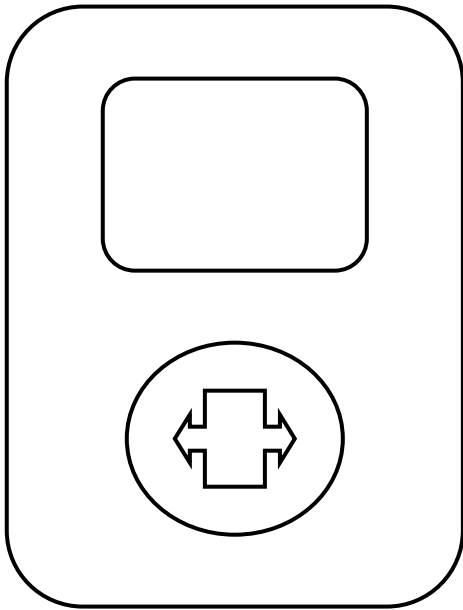

Command 1 \_\_\_\_\_

Command 2 \_\_\_\_\_

Command 3 \_\_\_\_\_

Command 4 \_\_\_\_\_

- (b) The drawing below has a length measurement of 80 mm as indicated. Explain the procedure involved in inserting the dimension as shown, using a CAD package.

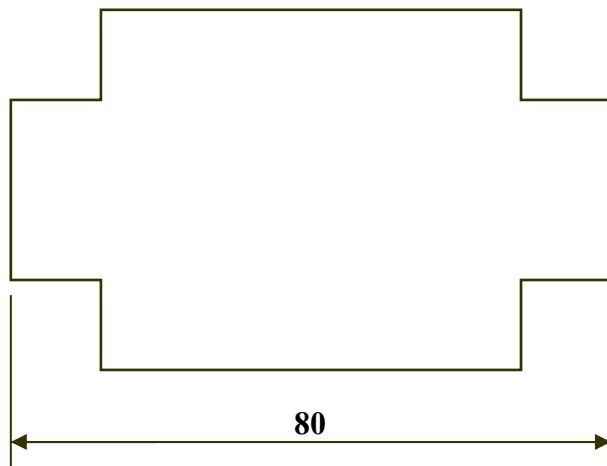

Procedure \_\_\_\_\_

\_\_\_\_\_

\_\_\_\_\_

(a) A diagram of an electrical buzzer game (steady hand game) is shown. Explain briefly how the game works, using the electrical parts as indicated.

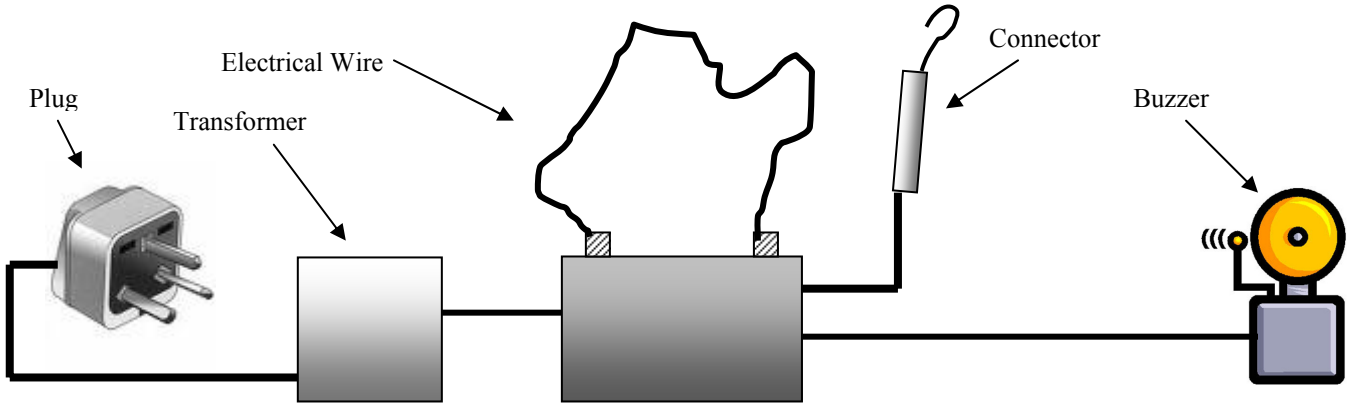

Explanation \_\_\_\_\_  
 \_\_\_\_\_  
 \_\_\_\_\_

(b) Name **any four** of the components shown below, and state a suitable use for **each**.



Name \_\_\_\_\_  
 Use \_\_\_\_\_  
 \_\_\_\_\_



Name \_\_\_\_\_  
 Use \_\_\_\_\_  
 \_\_\_\_\_



Name \_\_\_\_\_  
 Use \_\_\_\_\_  
 \_\_\_\_\_



Name \_\_\_\_\_  
 Use \_\_\_\_\_  
 \_\_\_\_\_



Name \_\_\_\_\_  
 Use \_\_\_\_\_  
 \_\_\_\_\_



Name \_\_\_\_\_  
 Use \_\_\_\_\_  
 \_\_\_\_\_

(a) Name and give a use for **each** of the **three** components shown.



Name \_\_\_\_\_

Use \_\_\_\_\_

\_\_\_\_\_



Name \_\_\_\_\_

Use \_\_\_\_\_

\_\_\_\_\_

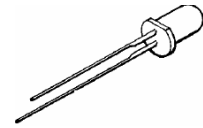

Name \_\_\_\_\_

Use \_\_\_\_\_

\_\_\_\_\_

(b) What is the purpose of the coloured bands shown on the resistor below?



Coloured Bands

Purpose of bands \_\_\_\_\_

(c) A house is close to a river that floods. A circuit, constructed to give an audible warning if water should start to enter the basement, is shown below. Explain how the circuit works.

---



---



---



---

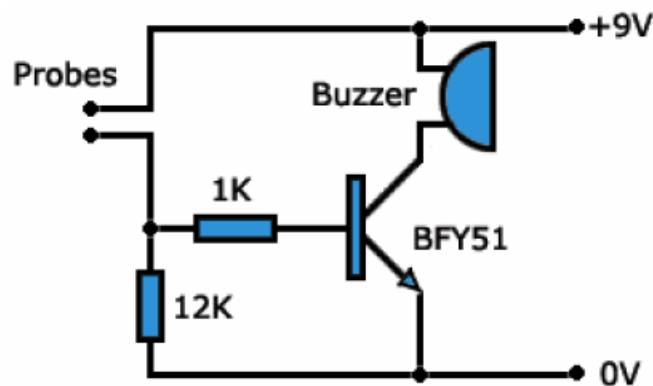

- (a) The diagram below shows a vehicle and its steering system. Explain how this mechanism allows direct turning of the wheels.

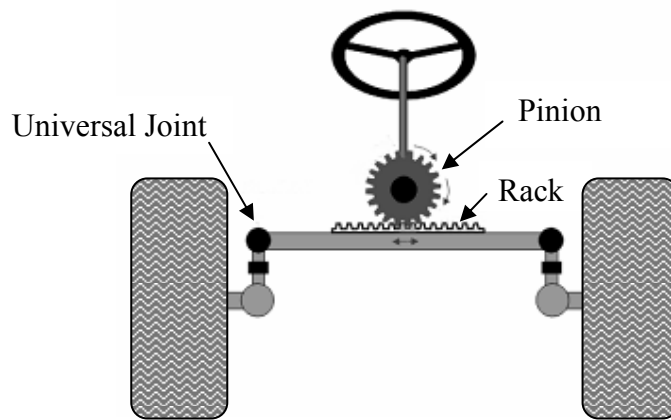

---



---



---

- (b) Identify the **three** mechanisms A, B and C, shown below, and state **one** use of **each**.

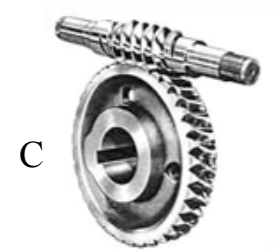
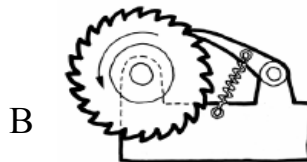
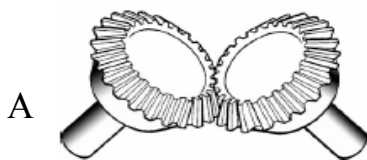

	Name	Use
Mechanism A		
Mechanism B		
Mechanism C		

(a) Name **any four** of the pneumatic symbols shown below, and give a suitable use for **each**.

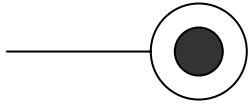

Name \_\_\_\_\_

Use \_\_\_\_\_

\_\_\_\_\_

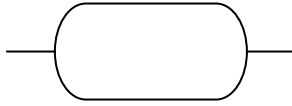

Name \_\_\_\_\_

Use \_\_\_\_\_

\_\_\_\_\_

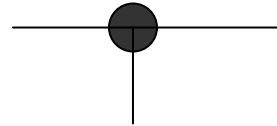

Name \_\_\_\_\_

Use \_\_\_\_\_

\_\_\_\_\_

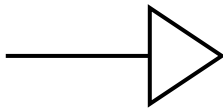

Name \_\_\_\_\_

Use \_\_\_\_\_

\_\_\_\_\_

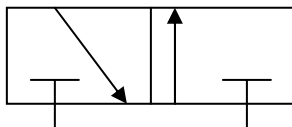

Name \_\_\_\_\_

Use \_\_\_\_\_

\_\_\_\_\_

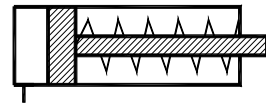

Name \_\_\_\_\_

Use \_\_\_\_\_

\_\_\_\_\_

(b) Identify the **two** pneumatic components shown below, and state their functions.

Component	Identify	Function (Use)
		

(c) Give **one** safety precaution that must be observed when using compressed air.

Safety Precaution \_\_\_\_\_  
 \_\_\_\_\_

Blank Page

Blank Page

Blank Page



<b>For Examiners use only</b>		
<b>Question</b>	<b>Mark</b>	<b>Total</b>
<b>Section 1</b>		
1		
2		
3		
<b>Section 2</b>		
4		
5		
6		
7 (a)		
7 (b)		
7 (c)		
7 (d)		
7 (e)		
<b>Total</b>		