



Coimisiún na Scrúduithe Stáit
State Examinations Commission
JUNIOR CERTIFICATE EXAMINATION, 2007

TECHNOLOGY

ORDINARY LEVEL

160 Marks

Wednesday 20 June, Afternoon 2.00 to 4.00

Centre
Number

Examination
Number

INSTRUCTIONS





1. Answer Section A and any two questions from Section B.
2. Write your answers in the spaces provided or tick the appropriate box.
3. Hand up this paper at the end of the examination.



1.	Total of end of page totals	
2.	Aggregate total of all disallowed question(s)	
3.	Total mark awarded (1 minus 2)	
4.	Bonus mark for answering through Irish (if applicable)	
5.	Total mark awarded if Irish Bonus (3+4)	
	Note: The mark in row 3 (or row 5 if an Irish bonus is awarded) must equal the mark in the Mór-Iomlán box on the script	

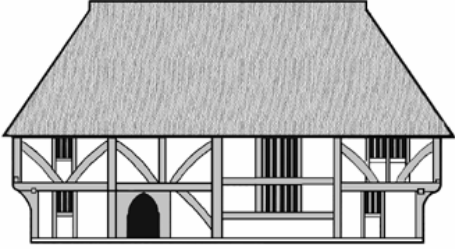

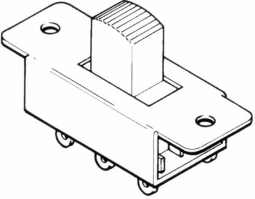
For Examiner	
Total Mark	<input style="width: 50px; height: 20px;" type="text"/>
Question	Mark
Section A	
Section B Q 1	
Section B Q 2	
Section B Q 3	
Section B Q 4	
Total	
Grade	

MAKE SURE TO WRITE YOUR EXAMINATION NUMBER IN THE
BOX PROVIDED ON THIS PAGE

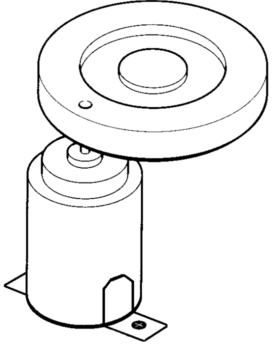
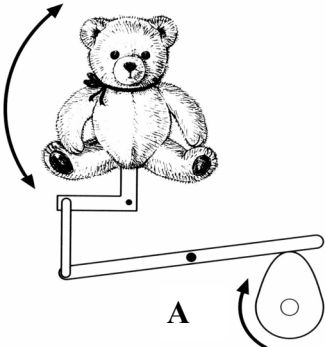
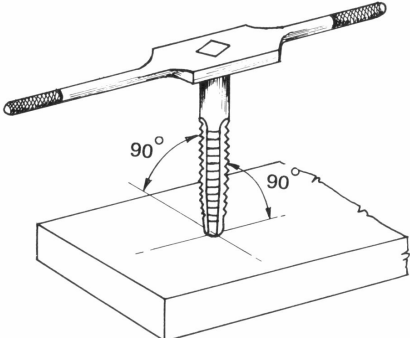
SECTION A – 80 MARKS ANSWER ANY SIXTEEN QUESTIONS IN THIS SECTION

<p>1.</p> 	<p>This drawing is an example of:</p>	<p>Oblique projection</p>	
		<p>Orthographic projection</p>	
		<p>Isometric projection</p>	
<p>2.</p> 	<p>Many small boat hulls are made from GRP. GRP stands for:</p>	<p>General rubberised plastic</p>	
		<p>Glass reinforced plastic</p>	
		<p>Graded resin plastic</p>	
<p>3.</p> 	<p>Digital music devices play:</p>	<p>CDs</p>	
		<p>Tapes</p>	
		<p>MP3s</p>	
<p>4.</p> 	<p>This is a:</p>	<p>Slide switch</p>	
		<p>Toggle switch</p>	
		<p>Rocker switch</p>	
<p>5.</p> 	<p>George Stephenson developed the first:</p>	<p>Public bus</p>	
		<p>Public telephone</p>	
		<p>Public steam railway</p>	

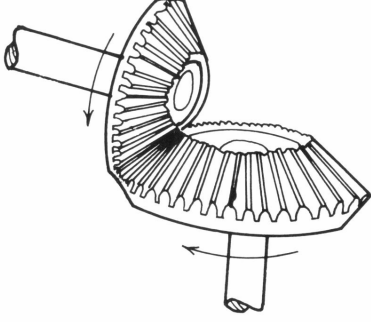
<p>6.</p> 	<p>When in motion, the wheel attached to the motor will cause the motor to:</p>	<p>Remain stable</p>	
		<p>Rotate faster</p>	
		<p>Vibrate</p>	
<p>7.</p> 	<p>The mechanism "A" is a:</p>	<p>Rack and pinion</p>	
		<p>Cam and follower</p>	
		<p>Crank slider</p>	
<p>8.</p> 	<p>This cutting tool is a:</p>	<p>Tap</p>	
		<p>Drill</p>	
		<p>Reamer</p>	
<p>9.</p> 	<p>Digital camera resolution is measured in:</p>	<p>Gigapixels</p>	
		<p>Megapixels</p>	
		<p>Kilopixels</p>	
<p>10.</p> 	<p>The skin of an inflatable boat is in:</p>	<p>Tension</p>	
		<p>Shear</p>	
		<p>Torsion</p>	

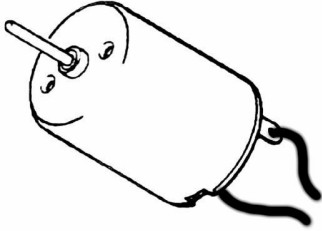
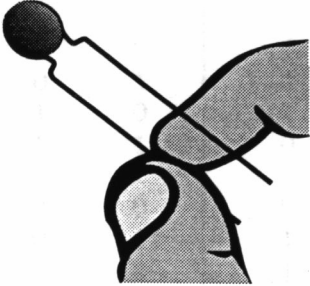
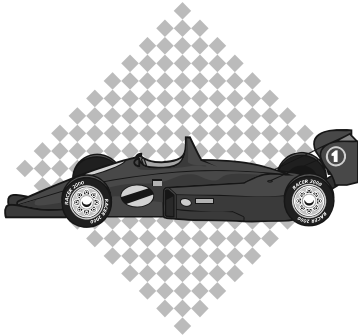
<p>11.</p> 	<p>Bevel gears transmit motion through:</p>	<p>90°</p>	
		<p>180°</p>	
		<p>360°</p>	
<p>12.</p> 	<p>Safety goggles must be worn when using a:</p>	<p>File</p>	
		<p>Band saw</p>	
		<p>Hot wire strip heater</p>	
<p>13.</p> 	<p>This is a:</p>	<p>Solenoid</p>	
		<p>Relay</p>	
		<p>Miniature Motor</p>	
<p>14.</p> 	<p>A thermistor is used in:</p>	<p>Temperature sensing circuits</p>	
		<p>Light sensing circuits</p>	
		<p>Moisture sensing circuits</p>	
<p>15.</p> 	<p>Formula One cars have:</p>	<p>A high centre of gravity</p>	
		<p>No centre of gravity</p>	
		<p>A low centre of gravity</p>	

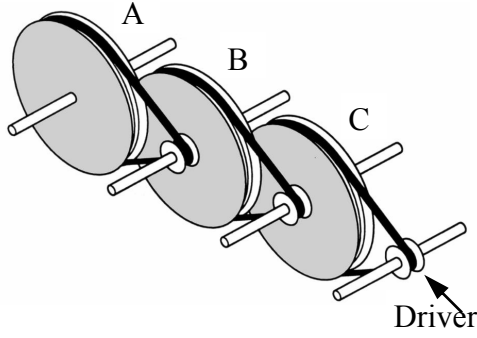
16.		In the diagram the slowest rotating pulley wheel is:	Pulley wheel A	
		Pulley wheel B		
		Pulley wheel C		

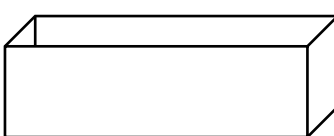
17.	Make a development of this open top container in the space opposite.	Development:
		

18.		LCD screens are used in mobile phones. LCD stands for:	Light crystal display	
			Liquid crystal display	
			Light crystal dispersion	

19.		The keys on a computer keyboard make contact as:	Push to break switches	
			Slide switches	
			Push to make switches	

20.		The lamp post for a street light is generally made from:	Cast Iron	
			Lead	
			Tin	

SECTION B – 80 MARKS
ANSWER ANY TWO QUESTIONS FROM THIS SECTION

1.

40 Marks

(a) A lever is used to turn the blade in this toy.

14 Marks

(i) Name the mechanism attached to the lever.

Mechanism: _____

(ii) State **two** advantages of using this mechanism.

1. _____

2. _____

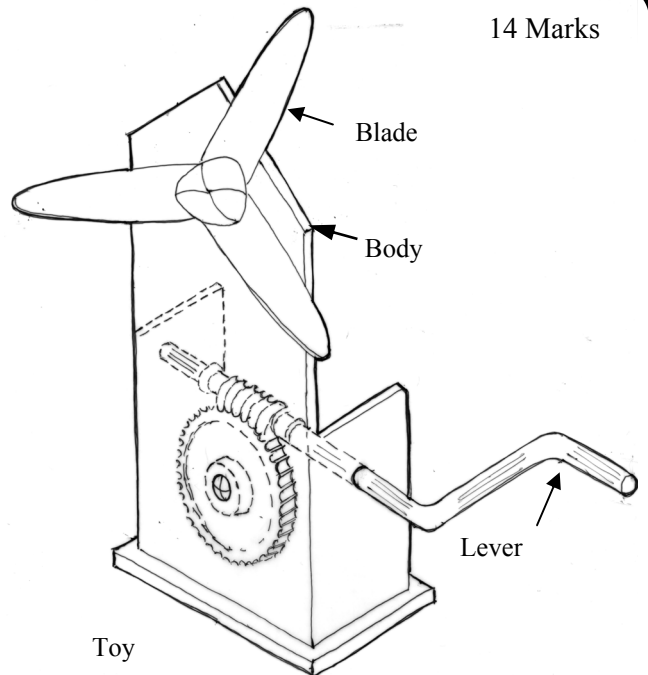

(iii) Another mechanism must be used to complete the project and drive the blade.

Which of the following mechanisms is the most suitable for this purpose?

Mechanisms: Gear train; pulley drive; rack and pinion.

Mechanism _____

Reason _____

(iv) When in use, it was found that the blade scratched the body of the toy.

Explain how you would solve this problem.

(b) (i) Name **two** materials that could be used to make the toy.

6 Marks

1. _____ 2. _____

(ii) Select **one** of these materials and explain how you would finish it to obtain a smooth safe edge.

Material: _____

(c) Complete the development of the body of the toy.

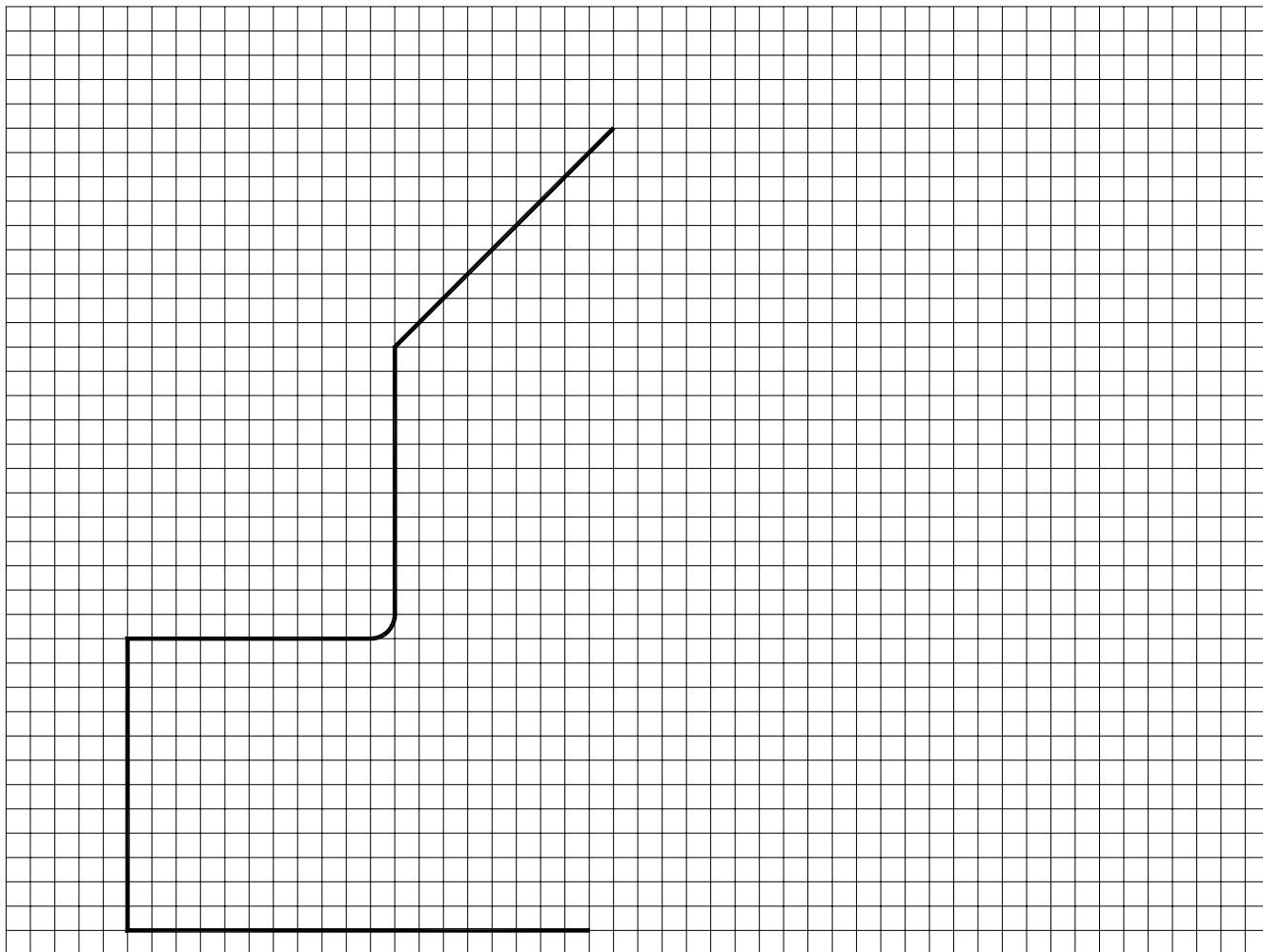

(d) (i) Describe **four** different steps in the manufacture of the body of this toy. For each step, name **one** tool or machine that you would use.

Step 1 _____

Step 2 _____

Step 3 _____

Step 4 _____

(ii) Name a suitable material for the lever: _____

2.

40 Marks

(a) An exploded drawing of a holder for a remote control for a TV is shown. If the remote control is removed from the holder, the LED flashes and a buzzer sounds.

Lever Microswitch

12 Marks

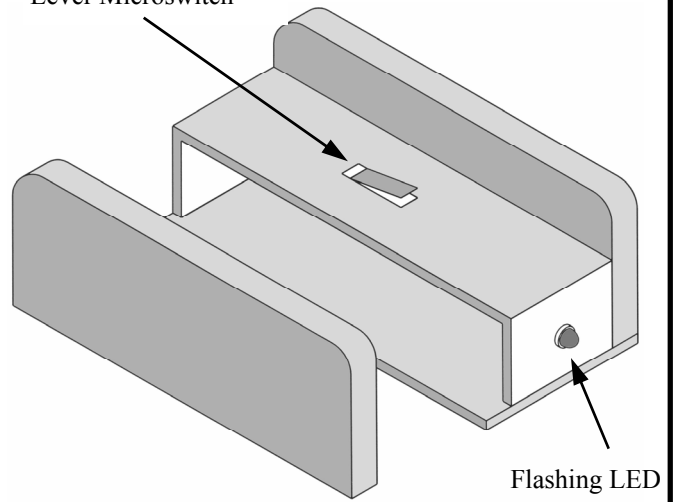

TV Remote Control holder

(i) Name a suitable material for the sides of the holder and give **two** reasons for your choice.

Material: _____

1. _____

2. _____

(ii) Suggest **two** methods of joining the sides to the base of the holder.

1. _____ 2. _____

(iii) Select **one** of these methods and explain **two** steps involved.

Method: _____

1. _____

2. _____

(b) Complete this circuit to show the buzzer and the LED connected in parallel.

8 Marks

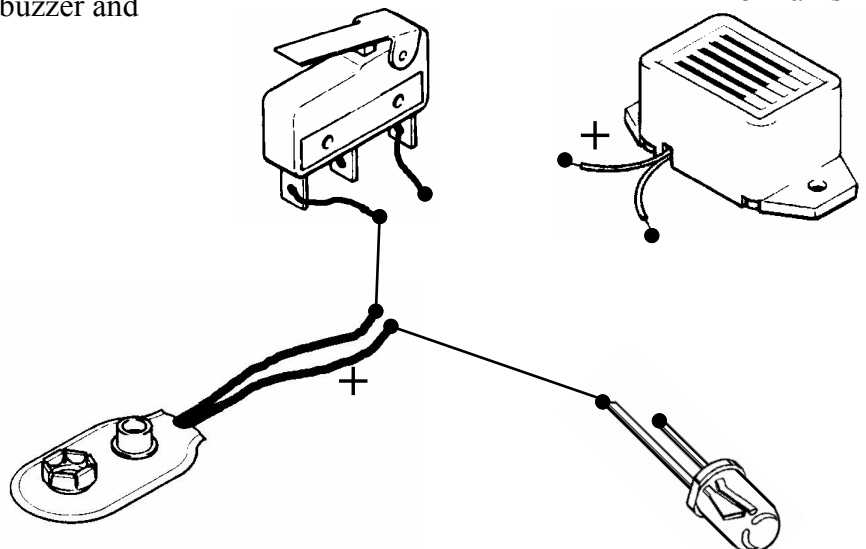

(c) On the grid draw a plan of the assembled remote control holder.

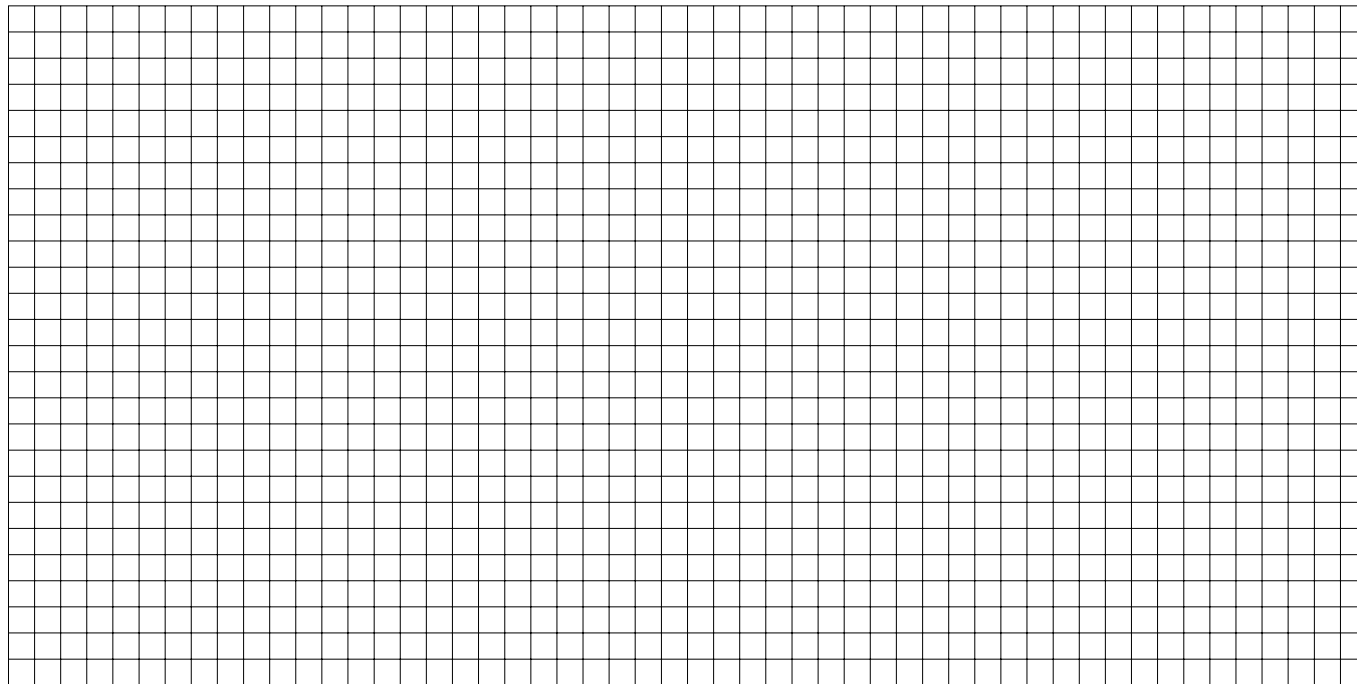

(d) The manufacturer requires a logo to be placed on the side of the holder.

Design a suitable logo.

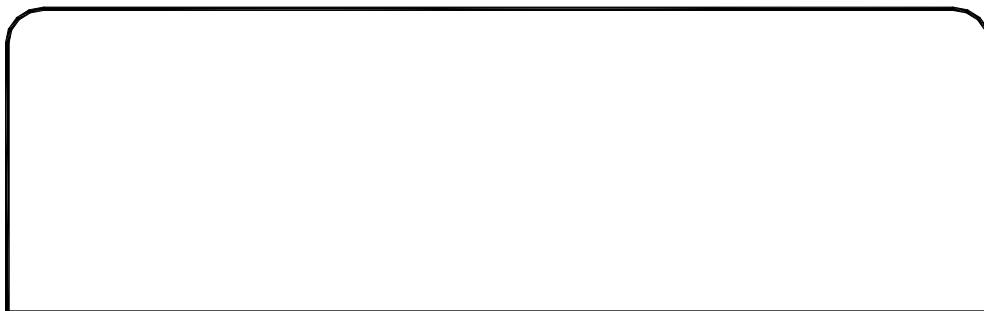

Side view of holder

(e) (i) Give **two** examples where remote control is used outside the home.

- 1. _____
- 2. _____

(ii) Give **two** examples of devices in the home that use automatic control.

- 1. _____
- 2. _____

(iii) State **two** advantages of automatic control in industry.

- 1. _____
 - 2. _____
- _____
- _____

3.

40 Marks

12 Marks

(a) A student's design for a desk tidy is shown.

(i) List **two** requirements that must be considered before designing a desk tidy.

1: _____

2: _____

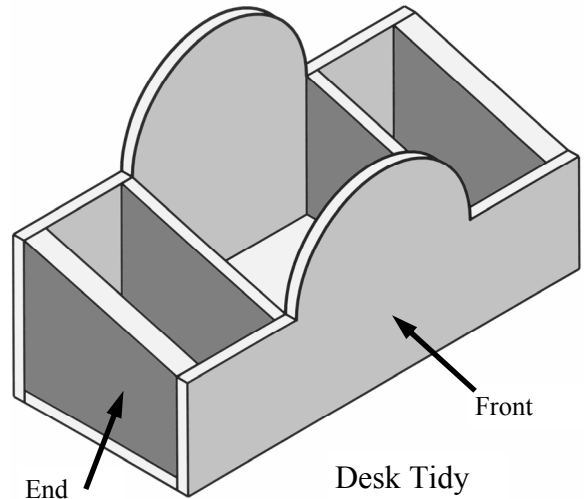

(ii) The ends of the unit are made from a hardwood. Name a suitable hardwood.

Hardwood: _____

(iii) Suggest a suitable material for the rest of the desk tidy and explain **three** steps in the manufacture of the front.

Material: _____

Step 1: _____

Step 2: _____

Step 3: _____

8 Marks

(b) Make neat sketches of **three** different tools that you would use to manufacture the desk tidy.

Name these tools.

1. _____

2. _____

3. _____

Sketches

(c) On the grid below draw an elevation of the desk tidy when viewed in the direction of the arrow.

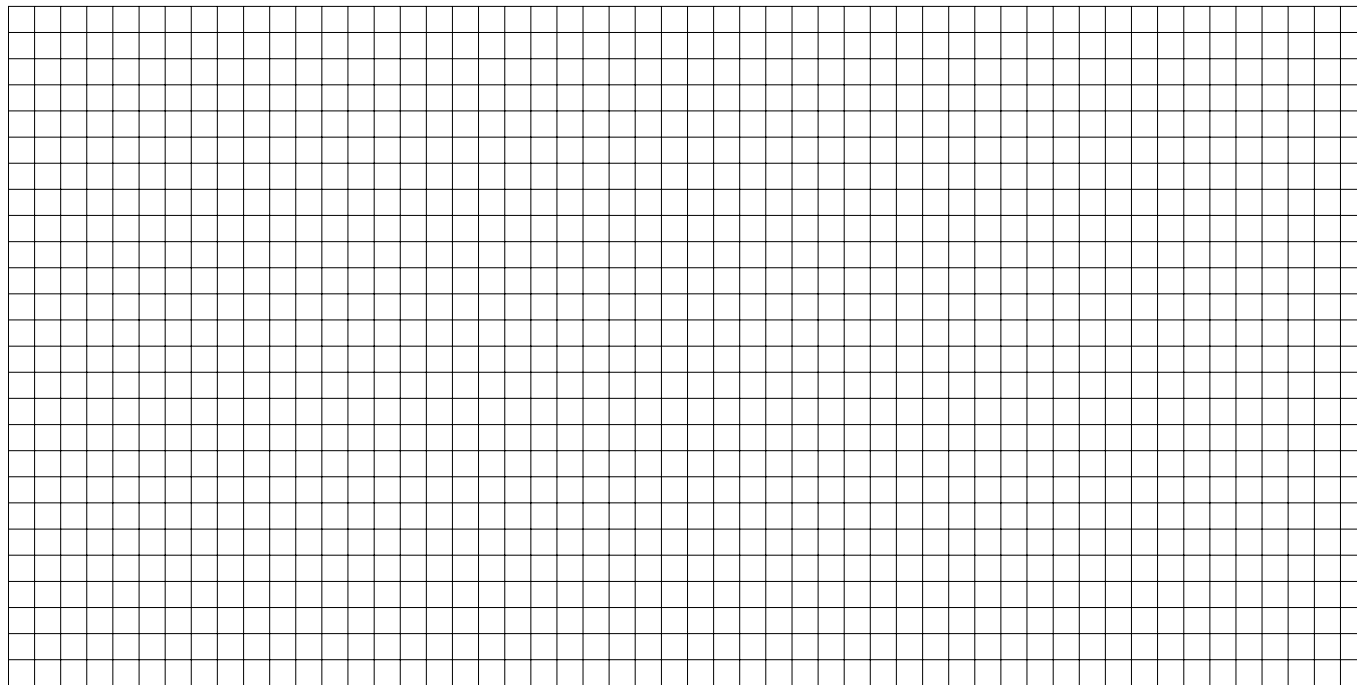
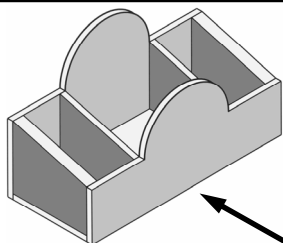

(d) (i) Sketch a different design for a desk tidy. What material will you use?

Sketch

Material: _____

(ii) When in use it was found that the desk tidy moved easily on the desk. How would you solve this problem?

(iii) Give an example of a question you would ask when evaluating the finished desk tidy?

- (a) (i) The picture shows a clockwork powered radio. Give **two** reasons why this radio would be suitable for use in some countries in Africa.

14 Marks



1. _____
- _____
2. _____
- _____

- (ii) List **two** ways to reduce energy consumption in Ireland.

1. _____
2. _____

- (iii) Name **two** small devices, other than a radio, that could be powered by a solar panel.

1. _____
2. _____

- (b) (i) Many of the everyday activities we do result in the release of carbon dioxide into the atmosphere. List **two** such activities:

16 Marks

1. _____
2. _____

- (ii) Suggest **three** major impacts that carbon dioxide emissions have on our planet.

1. _____
2. _____
3. _____

- (iii) Suggest **three** ways in which people can reduce carbon dioxide emissions.

1. _____
2. _____
3. _____

- (c) (i) Solar power is a type of renewable energy. List **three** other types of renewable energy.

10 Marks

1. _____
2. _____
3. _____

- (ii) List **one** advantage of each of these types of renewable energy.

1. _____
2. _____
3. _____