



S68T

Coimisiún na Scrúduithe Stáit State Examinations Commission

SCRÚDÚ AN TEASTAIS SHÓISEARAIGH, 2004

TEICNEOLAÍOCHT

GNÁTHLEIBHÉAL

160 Marks

Dé Céadaoin, 23 Meitheamh, Tráthnóna, 2.00 go dtí 4.00

Uimhir
an IonaidUimhir
Scrúdaithe

TREORACHA



1. Freagair Roinn A agus dhá cheist ar bith as Roinn B.
2. Scríobh na freagraí sna hionaid a oireann nó cuir tic sa bhosca cuí.
3. Tabhair an páipéar seo don Fheitheoir i ndeireadh an scrúdaithe.



1.	Iomlán na n-iomlán ag deireadh na leathanach	
2.	Iomlán na marcanna do cheisteanna nach ceadmhach	
3.	Iomlán na marcanna bronnta (1 lúide 2)	
4.	Bónas i gcóir freagartha tré Ghaeilge (más cuí)	
5.	Iomlán marcanna bronnta má tá Bónas i gceist (3 + 4)	
	Nóta: Ní mór na marcanna i sraith 3 (nó sraith 5 más cuí an Bónas tré Ghaeilge) a bheith ionann leis na marcanna sa bhosca Móriomlán ar an script	

Don Scrúdaitheoir	
Móriomlán na Marcanna	<input type="text"/>
Ceist	Marc
Roinn A	
Roinn B C1	
Roinn B C2	
Roinn B C3	
Roinn B C4	
Móriomlán	
Grád	

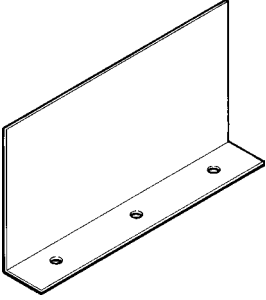
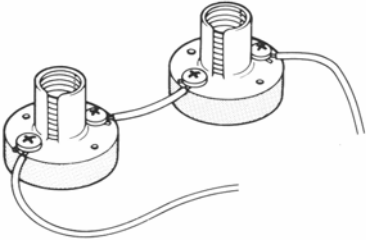
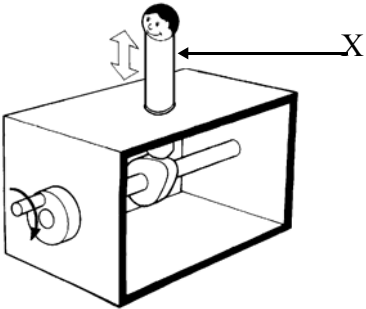

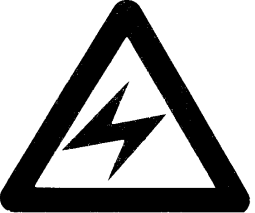
DÉAN DEIMHIN DE GO SCRÍOBHFAIDH TÚ D'UIMHIR SCRÚDAITHE SA BHOSCA CUÍ
AR AN LEATHANACH SEO.

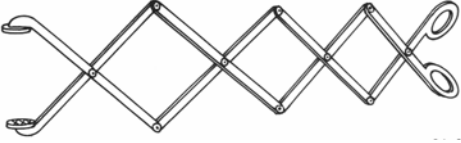
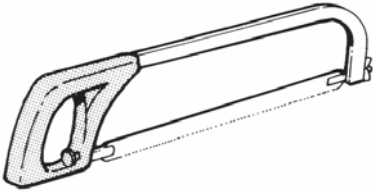
ROINN A – 80 MARC. FREAGAIR SÉ CHEIST DÉAG (16) AR BITH AS AN ROINN SEO

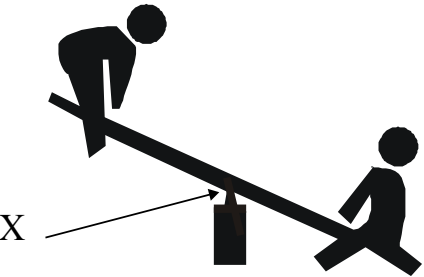
<p>1.</p> 	<p>Taispeántar an pháirt seo i(n):</p>	<p>Ortagrafach</p>	
		<p>Isiméadrach</p>	
		<p>Fiar</p>	
<p>2.</p> 	<p>Tá na gabhdáin bholgán:</p>	<p>Treocheangailte</p>	
		<p>Sraithcheangailte</p>	
		<p>Sraithcheangailte agus Treocheangailte</p>	
<p>3.</p> 	<p>Páirt 'X':</p>	<p>Rothlaíonn Sí</p>	
		<p>Frithingíonn Sí</p>	
		<p>Ascalaíonn Sí</p>	
<p>4.</p> 	<p>Is éard atá san fhuinseog ná:</p>	<p>Crua-adhmad</p>	
		<p>Bogadhmaid</p>	
		<p>Adhmaid Monaraithe</p>	
<p>5.</p> 	<p>Tugann an tsiombail seo rabhadh faoi:</p>	<p>Contúirt Tine</p>	
		<p>Contúirt Cheimiceach</p>	
		<p>Contúirt Leictreach</p>	

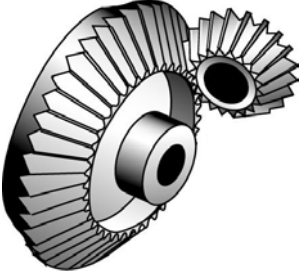
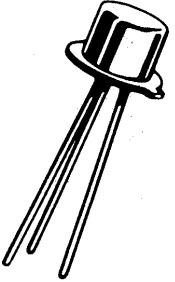
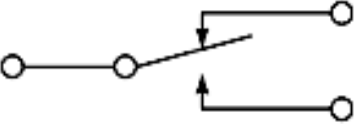
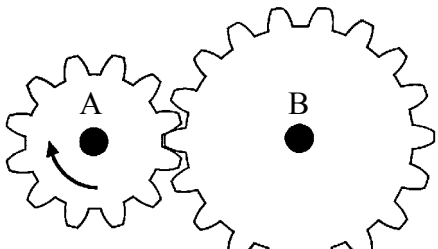
<p>6.</p> 	<p>Úsáideann an teanchair shínteach:</p>	<p>Nascáil Ghluaisne Chúltreo</p>	
		<p>Nascáil Chomhthreomhar</p>	
		<p>Nascáil Chlogadchromáin</p>	
<p>7.</p> 	<p>Is é atá san uirlis seo ná:</p>	<p>Sábh Cóipeála</p>	
		<p>Creimshábh</p>	
		<p>Sábh Miotail</p>	
<p>8.</p> 	<p>Tomhaistear sonraí ríomhaire i:</p>	<p>nGiodáin</p>	
		<p>mBearta</p>	
		<p>bPicteilíní</p>	
<p>9.</p> 	<p>Úsáideann rothair:</p>	<p>Tiomáint Ulóige</p>	
		<p>Tiomáint Ghiarshraithe</p>	
		<p>Tiomáint Roth Fiaclach & Slabhra</p>	
<p>10.</p> 	<p>Is é atá i bpointe 'X' ná:</p>	<p>An tUalach</p>	
		<p>An Buthal</p>	
		<p>An Iarracht</p>	

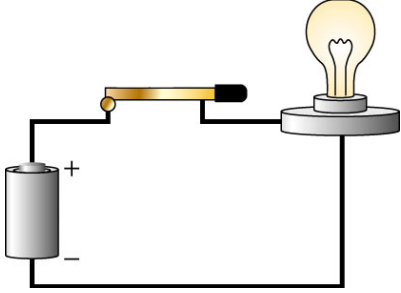
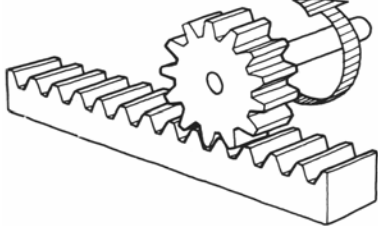
<p>11.</p> 	<p>Is éard atá anseo ná:</p>	<p>Sporghiaranna</p>																
		<p>Giaranna Héiliciúla</p>																
		<p>Beibhealghiaranna</p>																
<p>12.</p> 	<p>Is é atá sa chomhbhall leictreonach seo ná:</p>	<p>Dé-óid</p>																
		<p>Friotóir</p>																
		<p>Trasraitheoir</p>																
<p>13.</p> 	<p>Seasann an tsiombail seo do:</p>	<p>Lasc SPST</p>																
		<p>Lasc DPDT</p>																
		<p>Lasc SPDT</p>																
<p>14.</p>  <p>A = 12 Fiacail B = 18 Fiacail</p>	<p>Má rothlaíonn gear A de réir 150 RPM, rothlaíonn gear B de réir:</p>	<p>100 RPM</p>																
		<p>150 RPM</p>																
		<p>250 RPM</p>																
<p>15.</p> <table border="1" data-bbox="220 1758 576 2033"> <thead> <tr> <th>A</th> <th>B</th> <th>Q</th> </tr> </thead> <tbody> <tr> <td>0</td> <td>0</td> <td>0</td> </tr> <tr> <td>0</td> <td>1</td> <td>1</td> </tr> <tr> <td>1</td> <td>0</td> <td>1</td> </tr> <tr> <td>1</td> <td>1</td> <td>1</td> </tr> </tbody> </table>	A	B	Q	0	0	0	0	1	1	1	0	1	1	1	1	<p>Is é seo an tábla fírinne do:</p>	<p>Gheata AND</p>	
A	B	Q																
0	0	0																
0	1	1																
1	0	1																
1	1	1																
		<p>Gheata NOT</p>																
		<p>Gheata OR</p>																

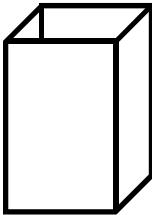
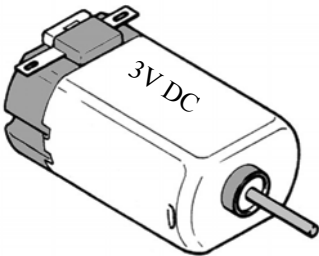
<p>16.</p> 	<p>Tomhaistear sruth i(n):</p>	<p>Voltanna</p>	
<p>17.</p> 	<p>Is é atá sa mheicníocht seo ná:</p>	<p>Raicín agus Ceapachóir</p>	
<p>18.</p> 	<p>Forbraíodh an t-inneall gaile ag:</p>	<p>Thomas Edison</p>	
<p>19.</p> 	<p>Tarraing forbairt dromchla an choimeádáin seo le barr oscailte.</p>	<p>George Stephenson</p>	
<p>20.</p> 	<p>Cas dó a seasann na litreacha DC?</p> <p>_____</p>	<p>Nicholas Otto</p>	

1.

(a) Taispeántar bugaí bréagáin a thiomántar le mótar. Roghnaíodh bileog aicrileach mar ábhar oiriúnach do na taobhphainéil. 14 Marc

(1) Tabhair **dhá** chúis gur roghnaíodh aicrileach.

1. _____

2. _____

(2) Ainmnigh an mheicníocht tiomána 'X'.

(3) Liostaigh **ceithre** staid i ndéantús na dtaobhphainéal.

1. _____
2. _____
3. _____
4. _____

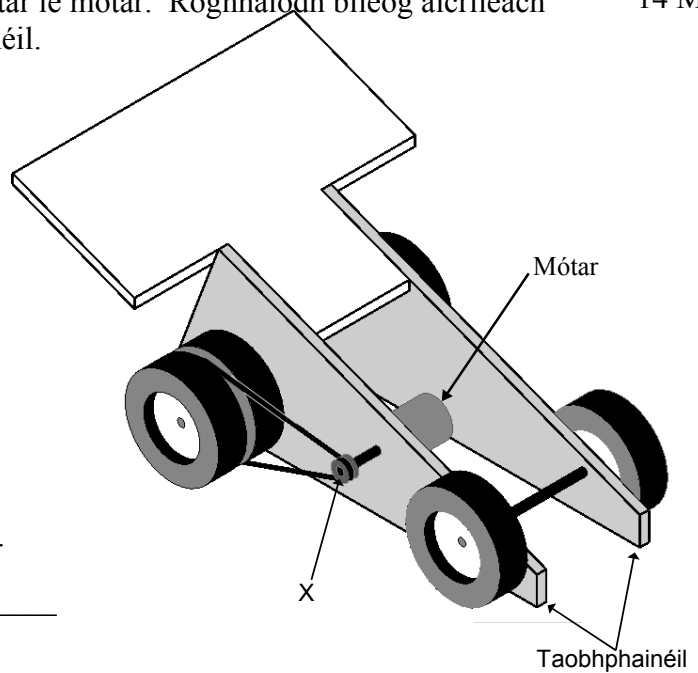

(b) (1) Liostaigh **dhá** bhuntáiste a bhaineann le meicníocht tiomána 'X' a úsáid. 8 Marc

1. _____
2. _____

(2) Mol meicníocht tiomána eile don bhugaí bréagáin.

(3) Conas a choinneofá na rothaí ó bheith ag cuimilt leis na taobhphainéil?

6 Marc

(c) Teaspántar na comhbhaill a úsáideadh chun an bugaí bréagáin a rialú. Tarraing na sreanga is gá chun an ciorcad a chríochnú.

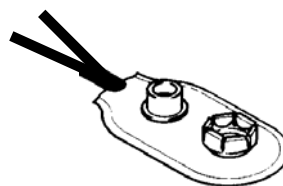
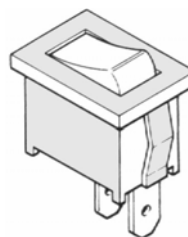
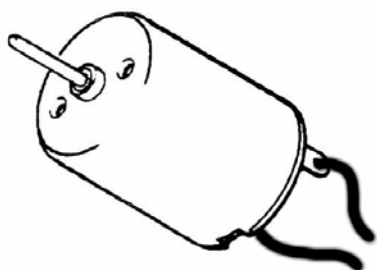

(d) (1) Tarraing lógo don bhuagáí bréagáin sa spás atá ann dó.

8 Marc

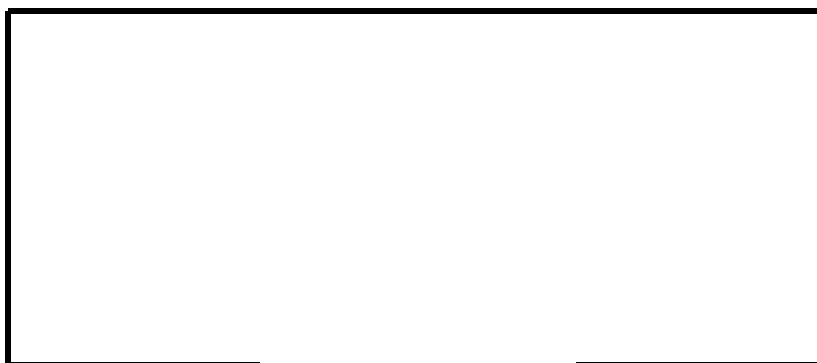

(ii) Cén fáth a n-úsáideann comhlachtaí lógónna dá gcuid táirgí?

(e) Mol **dhá** bhealach inar féidir feabhas a chur ar an mbugaí bréagáin chun é a dhéanamh níos sábháilte do pháistí óga.

4 Marc

1. _____

2. _____

(a) Taispeántar líníocht de thástálaí taisce ithreach.

10 Marc

- (1) Ainmnigh miotal oiriúnach ar chóir a úsáid chun na slata a dhéanamh. Tabhair cúis le do rogha.

Miotal: _____

Cúis: _____

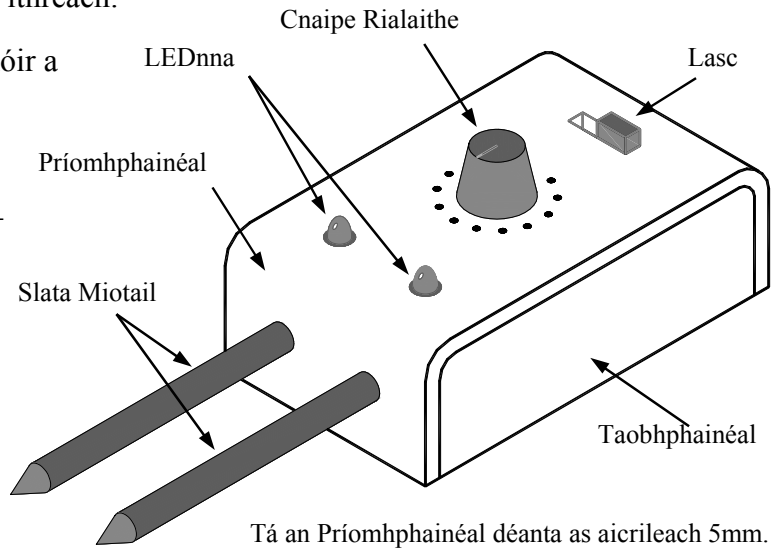

- (ii) Déan cur síos ar conas a dhéantar an sliotán don lasc.

- (3) Cad iad na réamhchúraimí ar chóir a dhéanamh nuair a bhíonn aicrileach á dhruileáil?

(b) Críochnaigh forbairt an phríomhphainéil.

8 Marc

8 Marc

(c) (i) Cad is brí leis na litreacha LED?

(ii) Cén fáth a bhfuil cos amháin den LED níos faide ná an ceann eile?

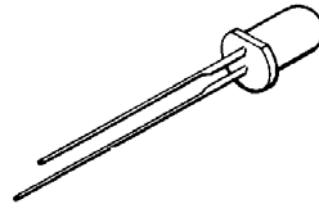

(iii) Ainmnigh an comhbhall leictreonach seo agus roghnaigh a siombail ón gcairt.

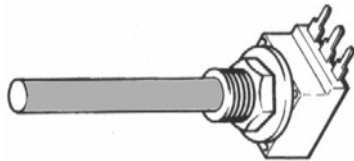

6 Marc

(d) (i) Déan cur síos ar conas a fhilltear an príomhphainéal ina chruth.

(ii) Liostaigh trí chéim is gá a thógáil chun críoch mhaith fhaobhair a aimsiú ar an aicrileach.

1. _____ 2. _____
3. _____

8 Marc

(e) (1) Ainmnigh ábhar oiriúnach don bhonn.

(2) Mol modh chun na taobhphainéil a shocrú ionas gur féidir bataire nua a chur isteach.

(3) Tarraing siombail don bhataire sa bhosca thíos.

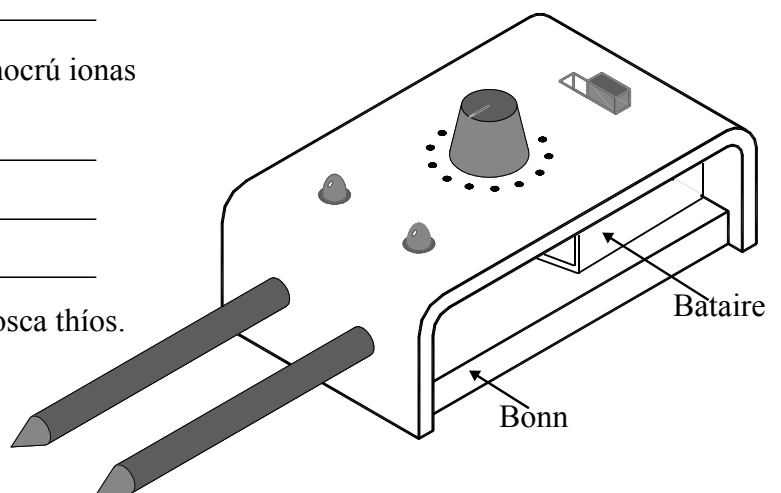

(a) Taispeántar líníocht de mhionsamhail d'aerbhád.

12 Marc

(i) Ainmnigh ábhar oiriúnach don chabhail agus liostaigh **dhá** airí a bhaineann leis an ábhar seo.

Abhar: _____

Airí 1: _____

Airí 2: _____

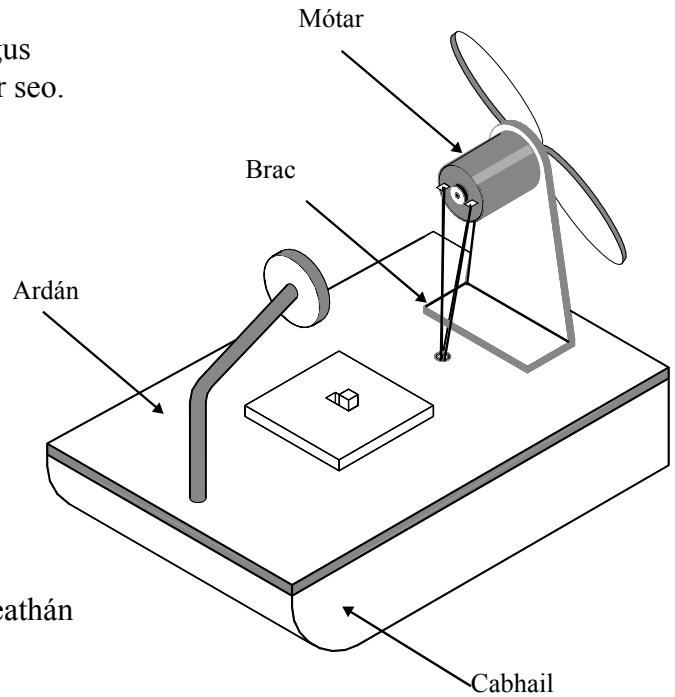

(2) Tabhair **dhá** chúis gur baineadh úsáid as leathán alúmanaim chun an brac a dhéanamh.

(3) Liostaigh **ceithre** staid i ndéantús an bhraic.

1. _____

2. _____

3. _____

4. _____

(b) (i) Nuair a tástáladh an lián rothlaigh sé sa treo mícheart. Abair conas is féidir an fhadhb a cheartú.

8 Marc

(ii) Cén próiseas is ceart a úsáid chun na sreanga a cheangal leis an mótar? _____

(3) Liostaigh **dhá** réamhchúram sábháilteachta a bhaineann leis an bpróiseas seo.

1. _____

2. _____

(c) Tarraing mionsceitse de chás sábháilteachta don lián.

8 Marc

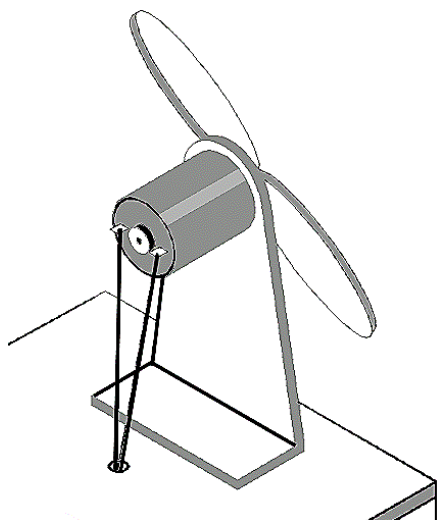

(d) Críochnaigh forbairt an bhraic.

8 Marc

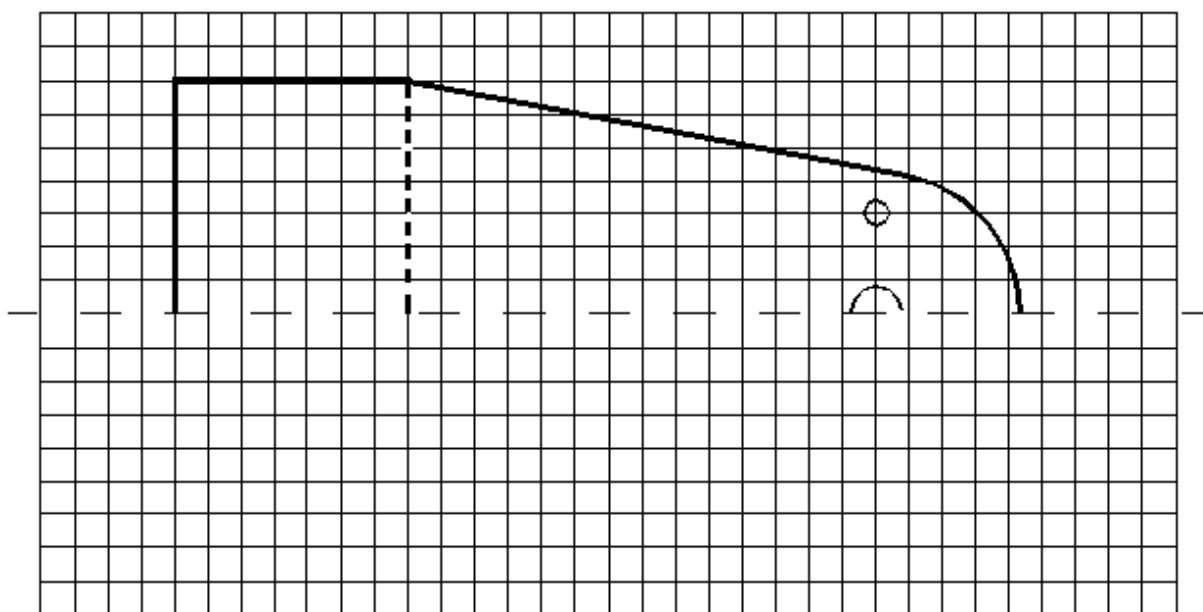

(e) Tarraing siombailí ciorcad don **Lasc** agus don **Mótar** sna boscaí.

4 Marc

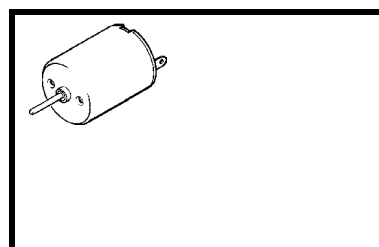
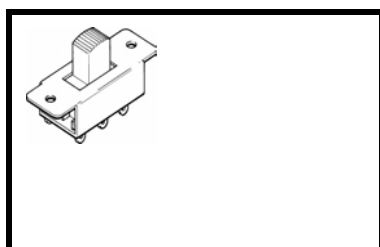

(a) (i) Is sampla de struchtúr fráma é an droichead seo.

14 Marc

Tabhair **dhá** shampla eile de struchtúir fráma.

1. _____
2. _____

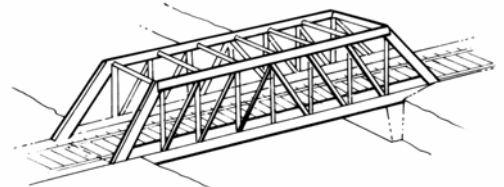

(2) Is féidir fórsaí éagsúla a oibriú ar struchtúr fráma. Ainmnigh **dhá** fhórsa den chineál sin.

1. _____
2. _____

(3) Cén fáth a n-úsáidtear triantáin i struchtúir frama?

(4) Tabhair **dhá** shampla de sceallstruchtúir.

1. _____
2. _____

(b) (i) Ainmnigh **dhá** chineál fuinnimh neamh-inathnuaite.

12 Marc

1. _____
2. _____

(2) Ainmnigh **dhá** chineál fuinnimh inathnuaite.

1. _____
2. _____

(3) Mol **dhá** bhealach chun an méid fuinnimh a úsáidimid a laghdú.

1. _____
2. _____

(c) (i) Liostaigh **dhá** bhealach inar chuidigh an teicneolaíocht nua-aoiseach leis an talmhaíocht.

8 Marc

1. _____
2. _____

(2) Liostaigh **dhá** bh ealach inar féidir an teicneolaíocht a úsáid chun fad a chur le saol seilfe tháirgí déiríochta.

1. _____
2. _____

(d) Maidir le dramhaíl, mínigh na téarmaí: Laghdaigh, Athchúrsáil agus Athúsáid.
Tabhair sampla de gach ceann díobh.

6 Marc

1. Laghdaigh: _____

Sampla: _____

2. Athchúrsáil: _____

Sampla: _____

3. Athúsáid: _____

Sampla: _____