



Coimisiún na Scrúduithe Stáit
State Examinations Commission

Junior Certificate 2012

Marking Scheme

Technical Graphics

Ordinary Level (v.2)



Junior Certificate Examination 2012

Technical Graphics O.L.



FSC



Marking Scheme
Sections A and B

Section A - Any ten questions from this section

Q1	3 9	Projection line to base of End Elevation (3 marks) Elevation / End Elevation – 3 lines – 3 marks per line (3x3 marks)
Q2	8 4	For a good quality, well proportioned freehand pictorial sketch (5 average quality or rule used) For colour or shading
Q3	6 6	Correct Advantage (6 marks) Correct Disadvantage (6 marks)
Q4	4 8	Semi-circle (4 marks) (2 marks if freehand or incorrect size) Drawing lines to complete (4x2 marks)
Q5	4 2 6	Correct location of F1 and F2 (4 marks) Bisection of angle for tangent (2 marks) Drawing line PL and horizontal line (2x3 marks)
Q6	7 5	14 Lines half mark per line (7 marks) For colour or shading (5 marks)
Q7	12	33-35 sq. metres = 12 marks (32 or 36 = 8 marks)
Q8	6 6	A = 600mm (6 marks) B = 900mm (6 marks)
Q9	8 4	Elevation of blocks – 4 rows 2 marks for each row correct (-1 mark each row incorrect) Good proportion
Q10	12	Location of 4 points of contact (4x3 marks)
Q11	6 6	Correct command (6 marks) Correct command (6 marks)
Q12	4 8	1 mark for each projection line to vertical plane 8 marks for correct outline (4 marks for incomplete outline)
Q13	2 10	Construction for Hexagon (2 marks) Drawing hexagon – 5 lines (5x2marks) (5 marks for irregular hexagon)
Q14	12	6 lines – 2 marks per line in perspective view (6 x 2 mark)
Q15	6 6	Correct angle of rotation (6 marks) Complete barrier length, height and complete (3x2 marks)
Total 120		

Section B - Any four questions from this section

Q 1: Orthographic Projection

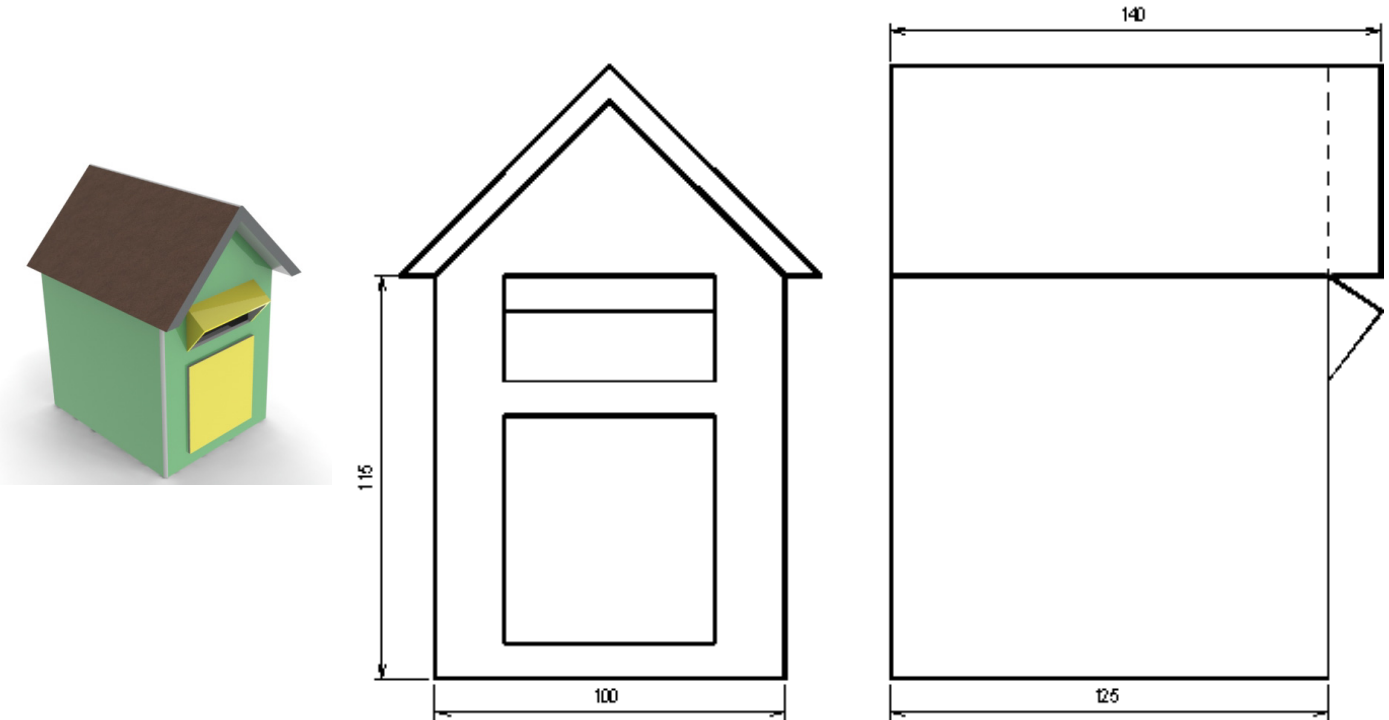

Orthographic Outline (10)	
10	Elevation and end elevation positioned correctly <i>(4 if not aligned or incorrect side, 1 view = 3 marks)</i>
Elevation (26)	
9	Box outline - 3 lines <i>(3x3 marks)</i>
8	Roof - 6 lines and correct angle <i>(6x1mark + 2 marks)</i>
5	Opening/cover - 5 lines <i>(5x1 mark)</i>
4	Door - 4 lines <i>(4x1 mark)</i>
End Elevation (18)	
6	Box outline - 3 lines <i>(3x2 marks)</i>
8	Roof - 4 lines <i>(4x2 marks)</i>
4	Cover - 2 lines <i>(2x2 marks)</i>
Dimension lines (4)	
4	4 dimension lines - <i>(4x1 mark)</i>
(12)	Drafting, accuracy and presentation
Total 70	

Q 2: Ellipse

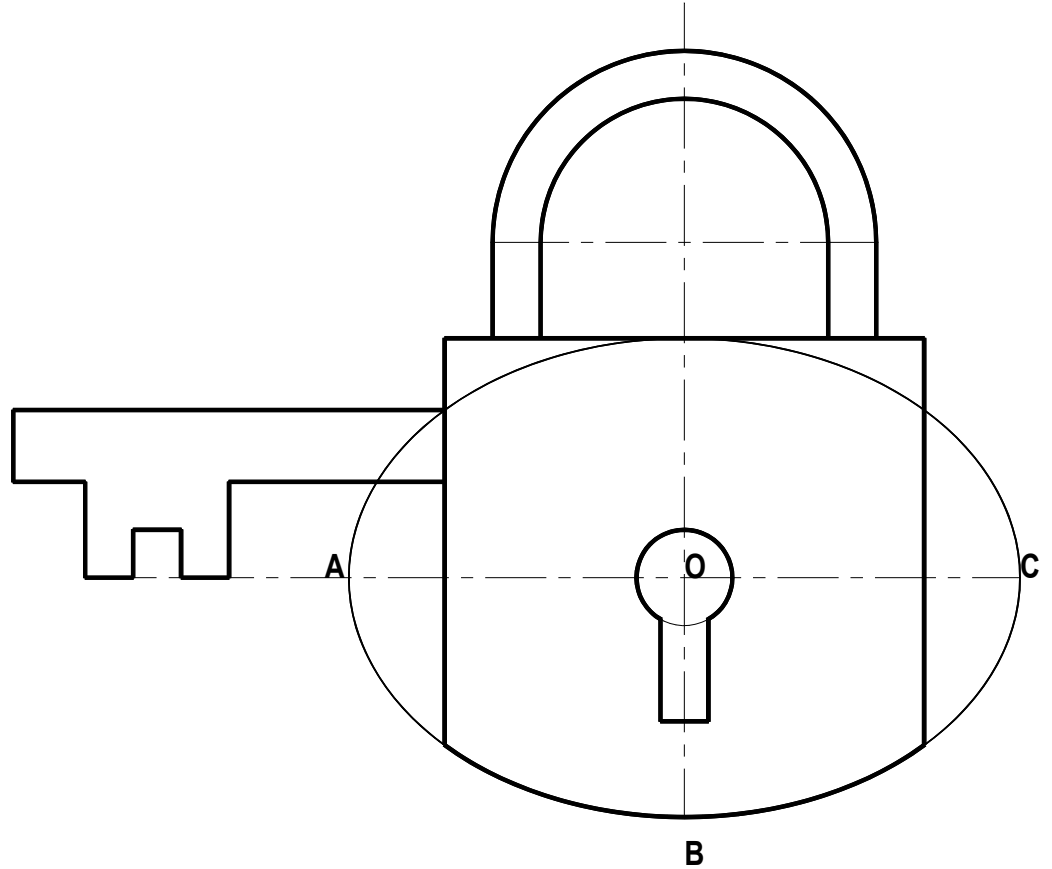

Body Construction (33)	
6	Semi-Ellipse; Major AC; Semi- minor OB – (2x3 marks)
10	Construction for semi-ellipse (<i>incorrect application = 4 marks</i>)
8	Drawing curve of ellipse ABC (8,6,4, <i>depending on quality</i>)
9	Body Outline shape - 3 lines (3x3 marks)
Top (8)	
8	4 lines - (4x1 mark) and 2 semi-circles - (2x2 marks)
Key-hole (6)	
6	Circle (3 marks) and 3 lines (3x1 mark)
Key shape (11)	
11	11 lines (11x1 mark)
(12)	Drafting, accuracy and presentation
Total 70	

Q 3: Surface Development

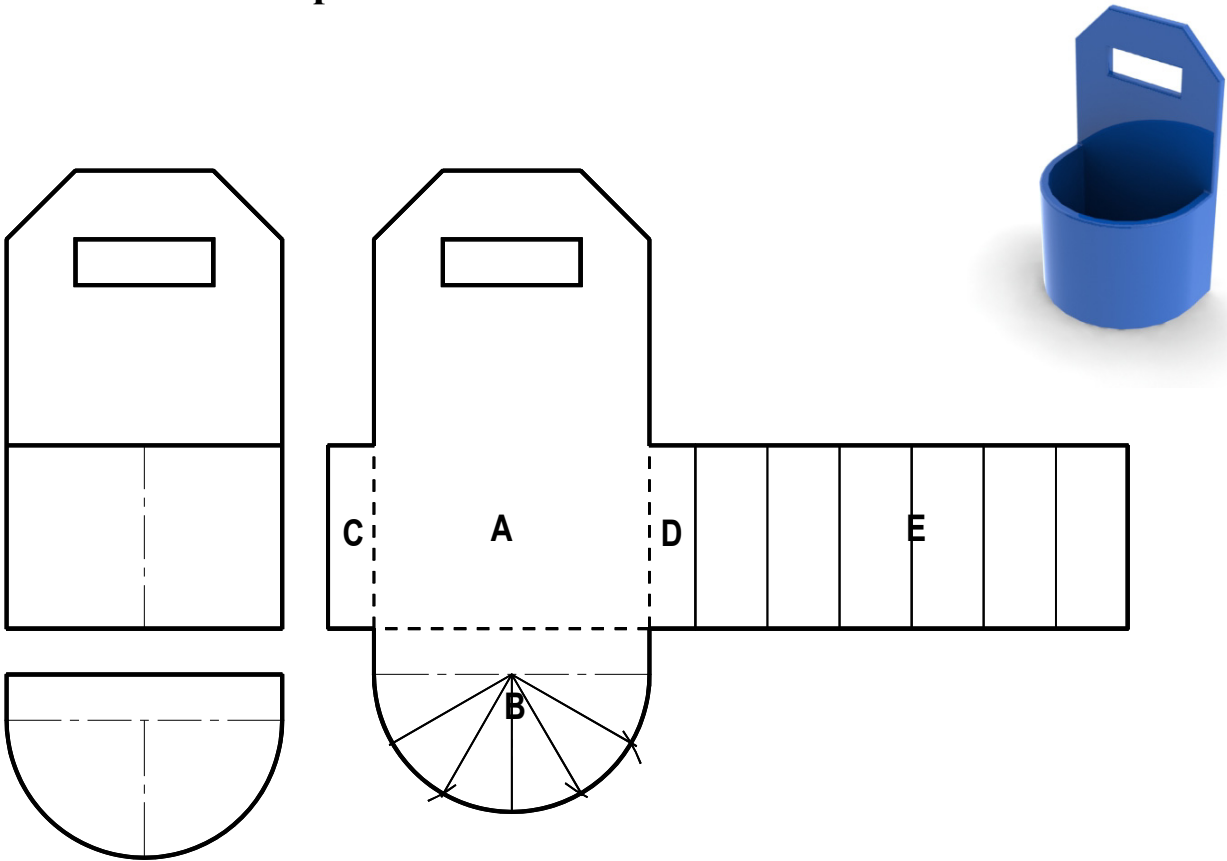

Orthographic (20)	
4	Elevation and plan in correct position <i>(Plan in wrong location or 1 view 2 marks)</i>
11	Elevation - 11 lines <i>(11x1 mark)</i>
5	Plan – 3 lines and r 30 <i>(3x1 marks +2marks)</i>
Development (38)	
10	Back A - 10 lines <i>(10x1 mark)</i>
7	Base B - 2 lines and semi-circle <i>(2x2 marks+3marks)</i>
6	Side C and Side D - 3 lines <i>(3x1 mark)</i> 3 lines <i>(3x1 mark)</i>
6	Construction for finding correct length of side E
6	Side E - 3 lines <i>(3x2 mark)</i>
3	Fold lines <i>(3x1 mark)</i>
(12)	Drafting, accuracy and presentation
Total 70	

Q 4: Isometric Projection

FSC

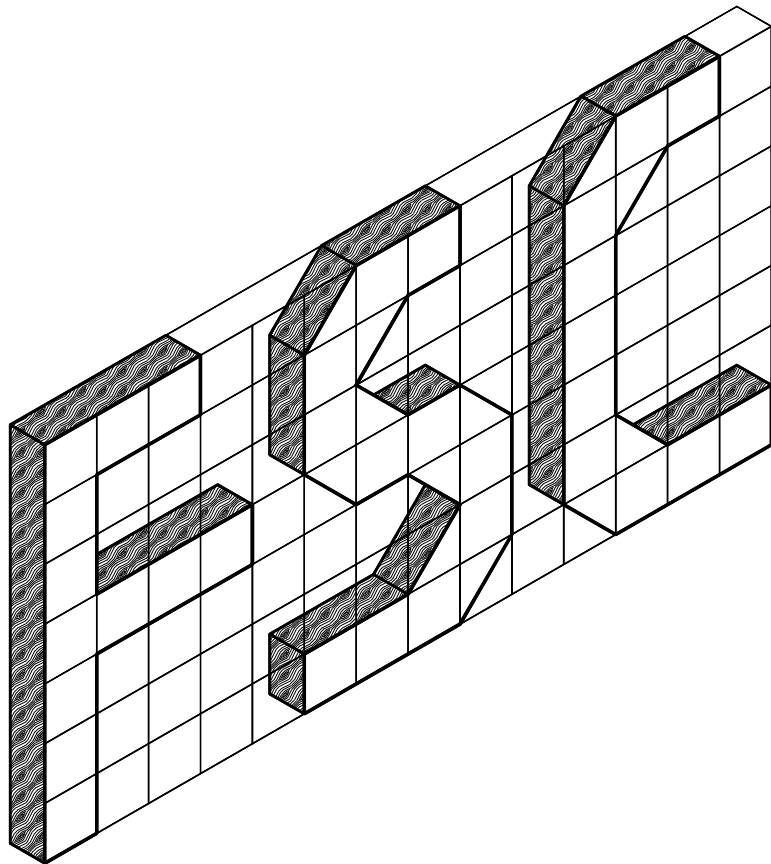

Setting Up (17)	
12	Height, length and width of grid (<i>3x4 marks</i>) (<i>deduct 2 each if inaccurate</i>)
5	Isometric outline (<i>deduct 2 + 3 if 30° angles are not used</i>)
Front Face (20)	
5	Letter F -10 lines (half mark each line)
9	Letter S -18 lines (half mark each line)
6	Letter C -12 lines (half mark each line)
Complete width (21)	7 marks per letter (<i>4 marks per letter if all lines are not put in</i>)
(12)	Drafting, accuracy and presentation
Total 70	

Q 4: Oblique Projection

FSC

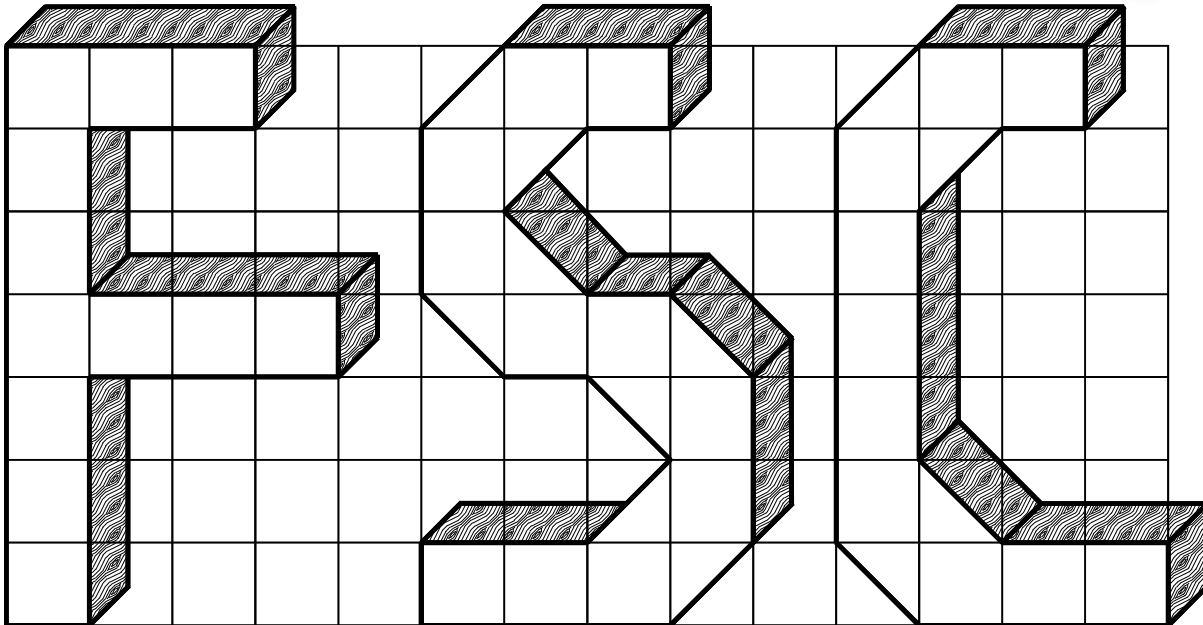

Setting Up (17)	
12	Height, length and width of grid (<i>3x4 marks</i>) (<i>deduct 2 each if inaccurate</i>)
5	Oblique outline (<i>deduct 5 marks if 45° angle not used</i>)
Front Face (20)	
5	Letter F -10 lines (half mark each line)
9	Letter S -18 lines (half mark each line)
6	Letter C -12 lines (half mark each line)
Complete width (21)	7 marks per letter (<i>4 marks per letter if all lines are not put in</i>)
(12)	Drafting, accuracy and presentation
Total 70	

Q 5: Transformation Geometry

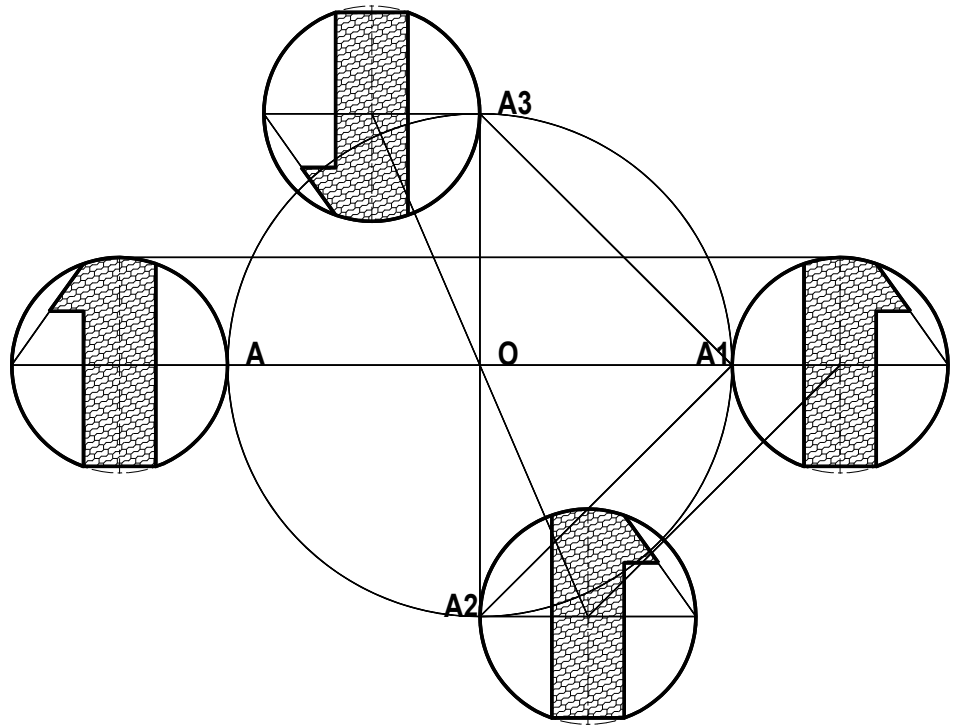

Setting up (16)	
10	Draw given fig ; Circle - 3 marks - 2 vertical lines – 2x2 marks 2 horizontal and line at angle - 3x1 mark
4	Locating points A, A1, A2, A3 (4 x 1 mark)
2	Locating point O
Axial Symmetry (14)	
4	Drawing lines perpendicular to A2-A3 (correct position and orientation)
10	Drawing fig. as above
Translation (14)	
4	Projection lines parallel to A1-A2
10	Drawing fig. as above
Central Symmetry (14)	
4	Drawing lines through centre point O
10	Drawing Fig. as above
(12)	Drafting, accuracy and presentation
Total 70	

Q 6: Circles and Tangents

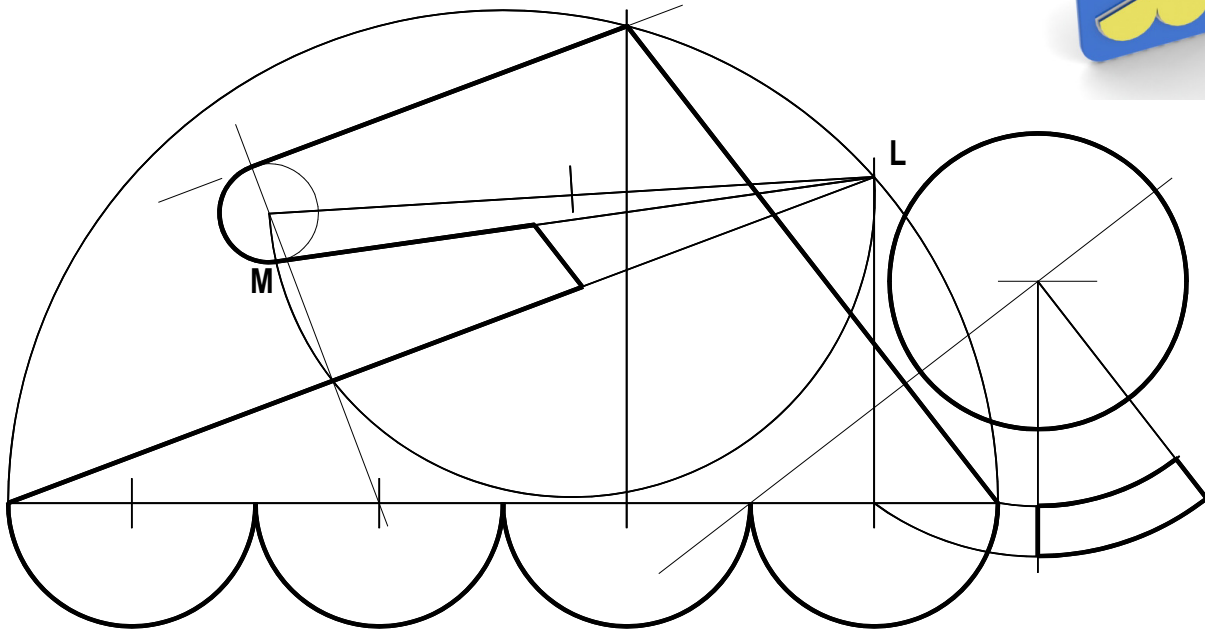

Outline Construction(18)	
6	R100 Circle (6 marks)
12	4 semi-circles (4x3 marks)
Arm (23)	
4	2 vertical lines (2x2 mark)
7	2 parallel lines to left side (2x2 marks) and line at 90 (3 marks)
4	2 parallel lines to right side (2x2 marks)
4	R10 Circle (4 marks)
4	Tangent construction and line (2x2 marks)
Head (17)	
6	Height 70 and line at 90 (2x3 marks)
3	R30 Circle (3 marks)
8	2 Arcs (2x2 marks) and 2 lines (2x2 marks)
(12)	Drafting, accuracy and presentation
Total 70	