



Coimisiún na Scrúduithe Stáit  
State Examinations Commission  
**JUNIOR CERTIFICATE EXAMINATION, 2003**

S 60 A

**TECHNICAL GRAPHICS — ORDINARY LEVEL**

**A**

**THURSDAY 12 JUNE-MORNING, 9.30 — 12.00**

**TOTAL MARKS 400 (Section A and B)**

**EXAMINATION NUMBER** 

**CENTRE STAMP** 

**INSTRUCTIONS**

(a) Answer any ten of the short answer questions in Section A (120 marks) using the spaces provided.

All questions in Section A carry equal marks.

(b) Answer any four of the six questions in Section B (280 marks).

All questions in Section B carry equal marks.



(c) Examination Number must be distinctly marked in the space provided above and on each sheet of paper used.

(d) All construction lines must be clearly shown.

(e) All measurements are in millimetres.

(f) Hand up this answer book (Section A) at the end of the examination.

**For Examiner's use only**

QUESTION	MARK
Section A (Total)	
Section B Q1	
Q2	
Q3	
Q4	
Q5	
Q6	
<b>TOTAL</b> 	
<b>GRADE</b> 	

**WARNING**

**THIS ANSWERBOOK MUST BE HANDED UP  
AT THE END OF THE EXAMINATION  
OTHERWISE MARKS WILL BE LOST.**

**SECTION A ANSWER ANY TEN QUESTIONS - ALL QUESTIONS CARRY EQUAL MARKS**

**1** Shown is the elevation, plan and end view of a set of steps.  
 Insert the lines omitted in the end view and in the plan.

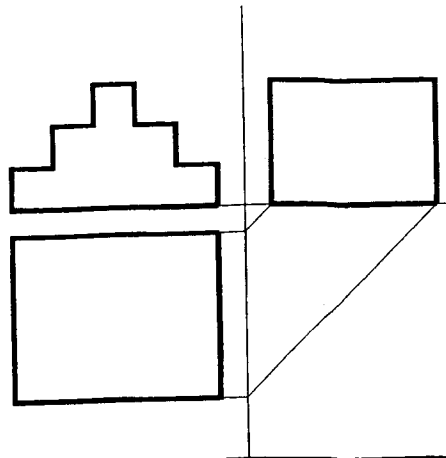

**2** Make a freehand pictorial sketch of the block in the space provided.

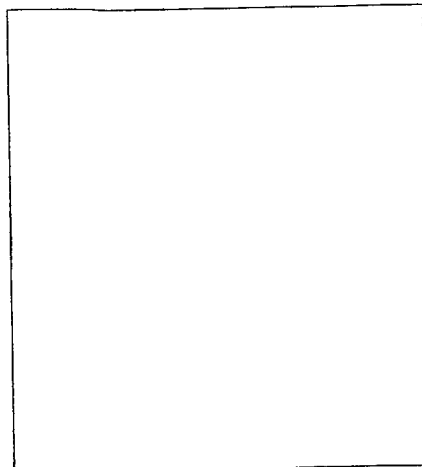
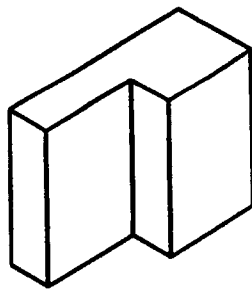

**3** Identify the computer components shown at **A** and **B**, below.

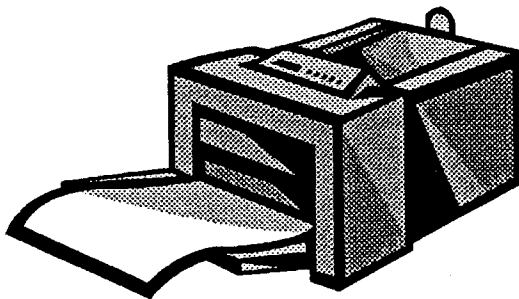

**A**

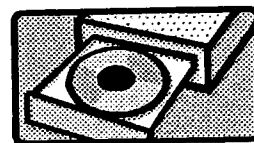

**B**

**A** = \_\_\_\_\_

**B** = \_\_\_\_\_

- 4 Convert the square to a triangle of equal area.

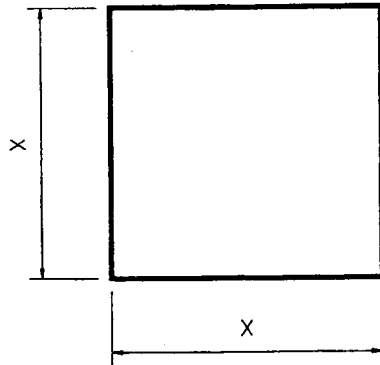

- 5 Construct a tangent to the ellipse at the point P. Show all constructions.

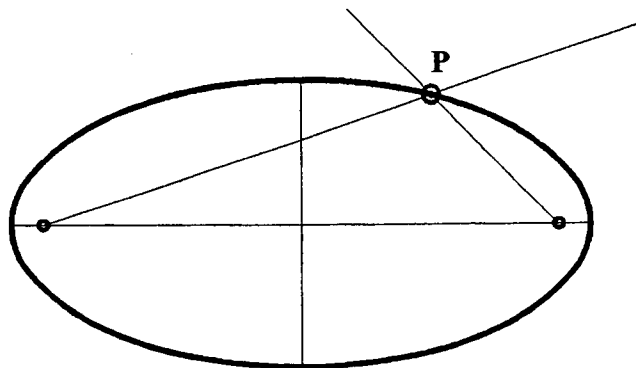

- 6 Three corners of the rectangle are filleted to a radius of 10mm. Fillet the corner X to a radius of 10mm, showing all constructions.

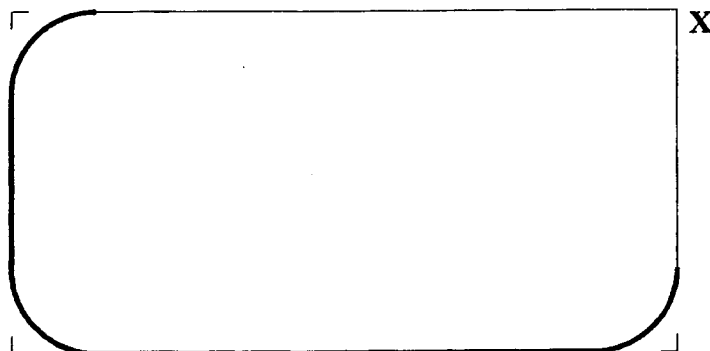

7

The elevation and plan of a **door-stopper** are shown.  
Complete the isometric view of the door-stopper on the grid provided.

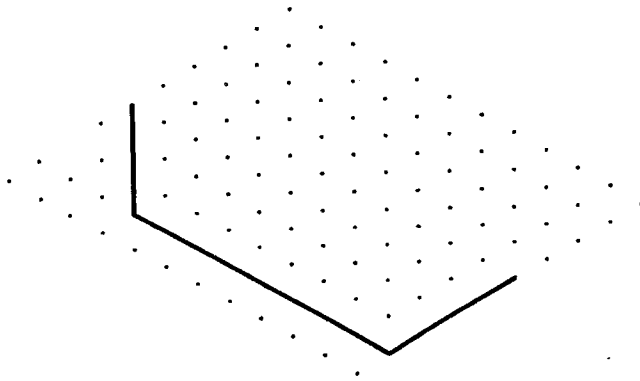
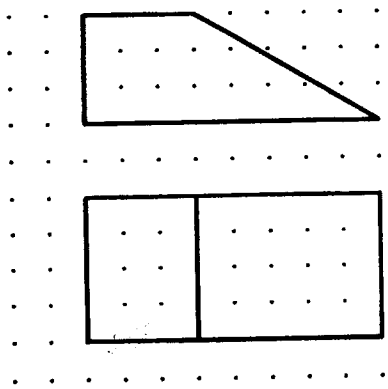

8

Using the scale provided, measure and record the dimensions A and B.

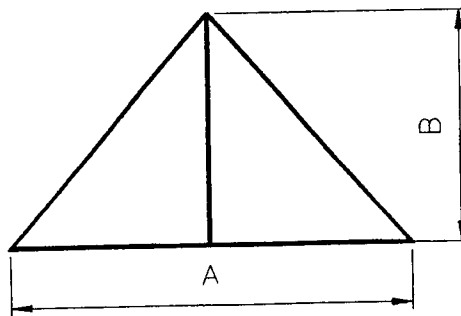
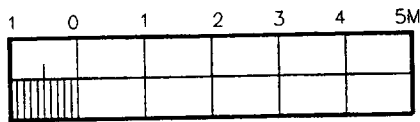

A = \_\_\_\_\_

B = \_\_\_\_\_

9

Determine the area of the tiled pathway, which surrounds the fish pond, in square units.

1 square = 1 x 1 Unit.

Answer :- \_\_\_\_\_

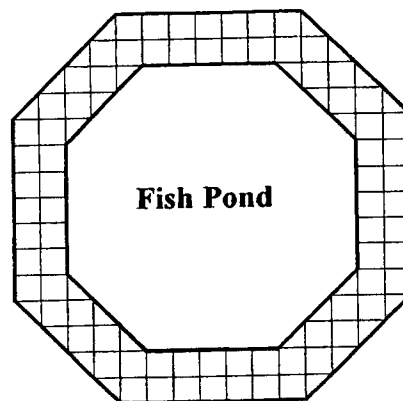

- 10 The elevation and plan of a cone are shown.  
Project an **auxiliary elevation**, on the given  $X_1 - Y_1$  line.

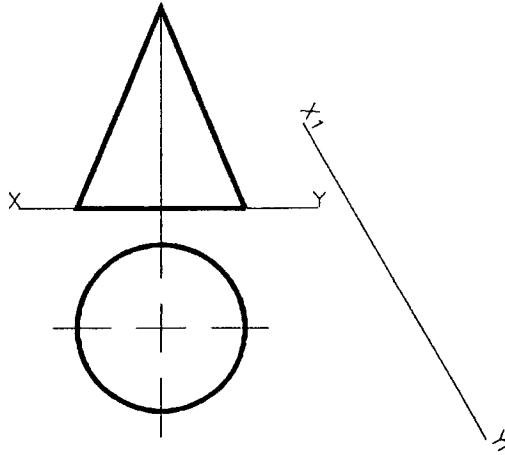

- 11 Using the grid provided, **sketch** the orthographic views indicated by the arrows.

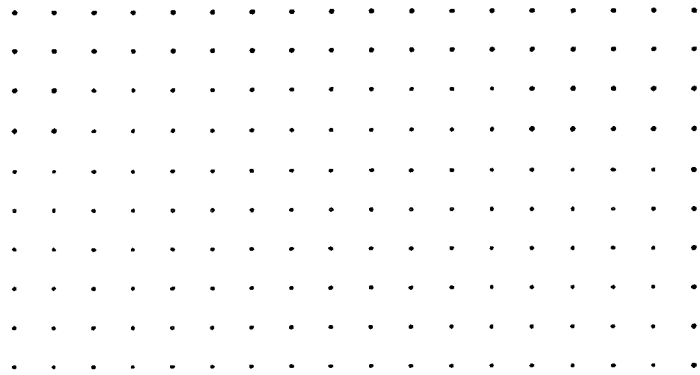
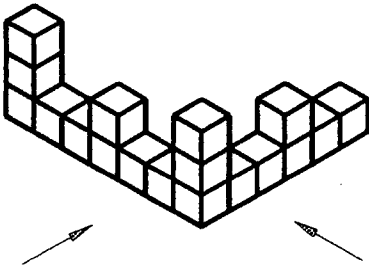

- 12 Sketch the **shadow** cast by the solid when the light source is as shown by the arrow.

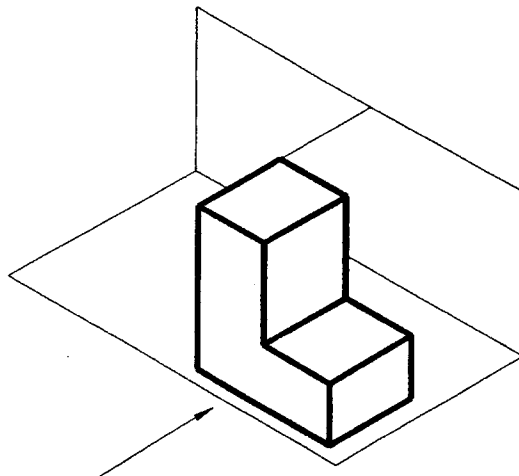

13 A link for a bicycle chain is shown. The centre for arc A is shown at O. Locate the points of contact, between arc A and circles B and C.

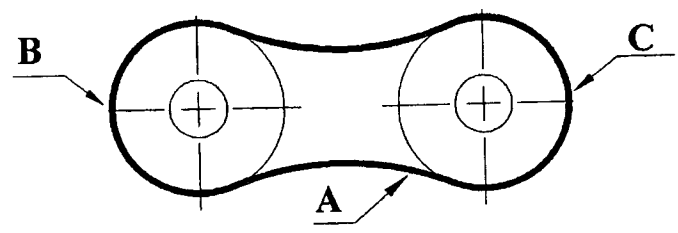

+ O

14 The figure shows the incomplete two point perspective outline of a podium. Complete the perspective outline, similar to the view shown at A.

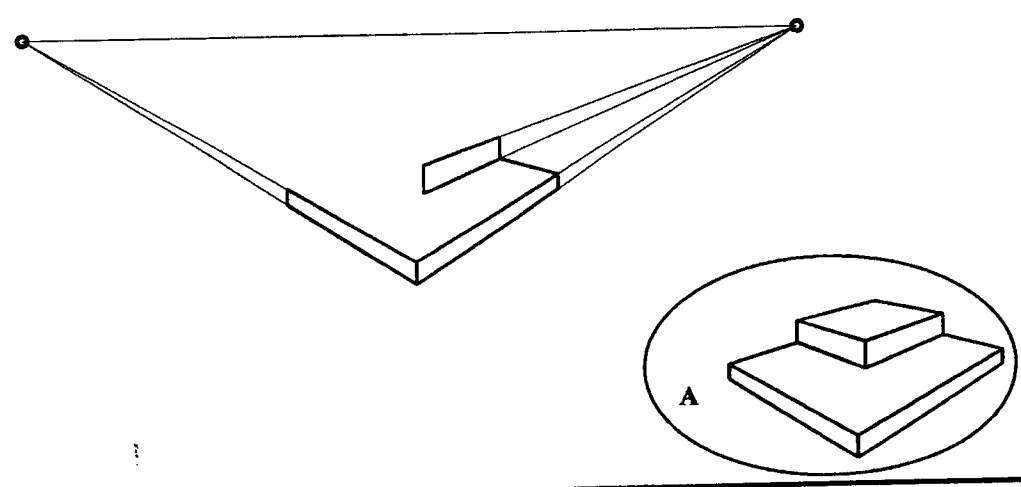

15 The figure shows a magnetic compass. Use a protractor to measure and record the amount of anti-clockwise rotation from North to West.

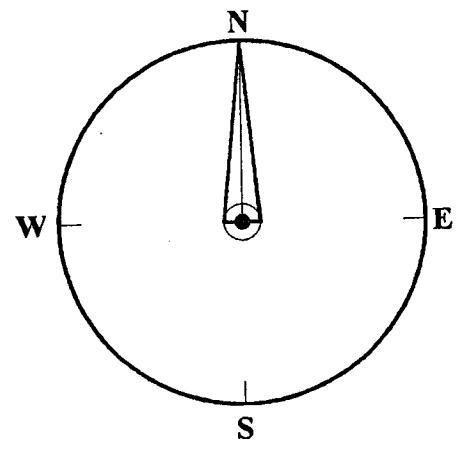

Answer:- \_\_\_\_\_

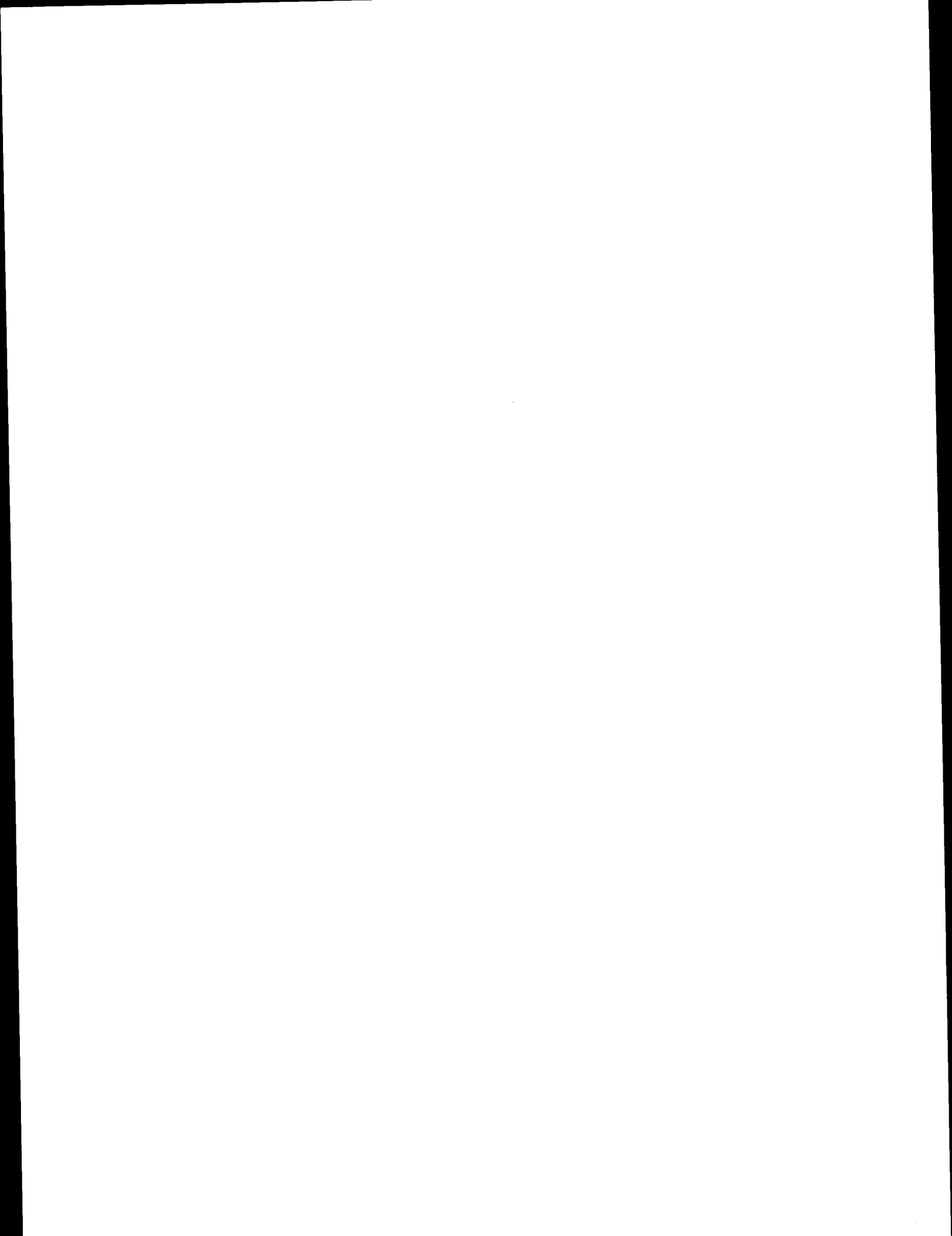



Coimisiún na Scrúduithe Stáit  
State Examinations Commission

S 60 B

**JUNIOR CERTIFICATE EXAMINATION, 2003**

**B**

**TECHNICAL GRAPHICS — ORDINARY LEVEL**

**THURSDAY 12 JUNE-MORNING, 9.30 — 12.00**

**SECTION B — 280 MARKS**

**INSTRUCTIONS FOR SECTION B**

- (a) Any four questions to be answered.
- (b) All questions in this section carry equal marks.
- (c) The number of the question must be distinctly marked by the side of each answer.
- (d) Work on one side of the paper only.
- (e) Examination number must be distinctly marked on each sheet of paper used.





**SECTION B** (ANSWER ANY FOUR QUESTIONS - ALL QUESTIONS CARRY EQUAL MARKS)

1

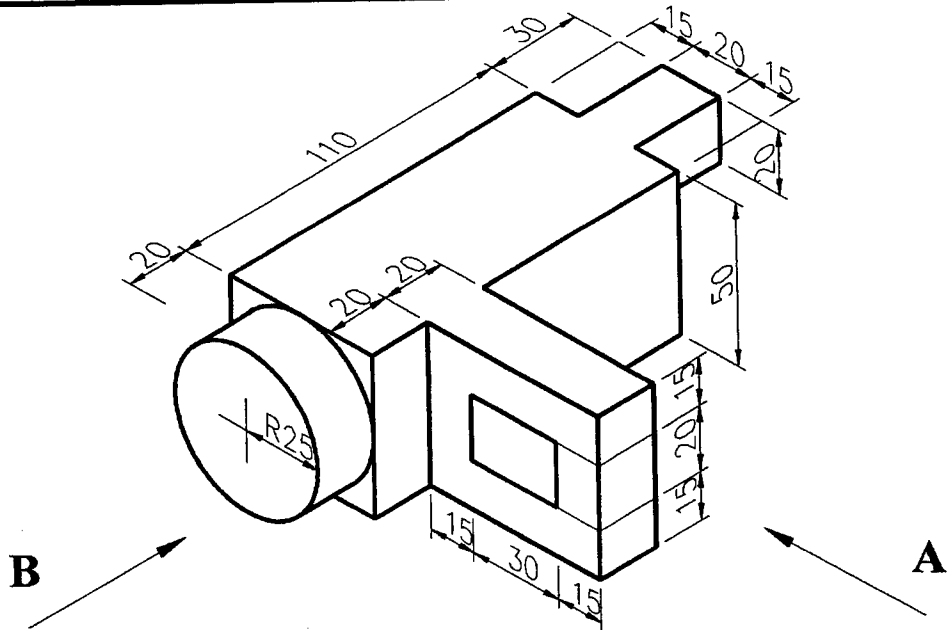

The figure shows the outline of a **camcorder**.

Draw :-

- (a) A front elevation looking in the direction of arrow A.
- (b) An end elevation looking in the direction of arrow B.
- (c) A plan projected from the front elevation.

Insert any **FOUR** dimensions.

2

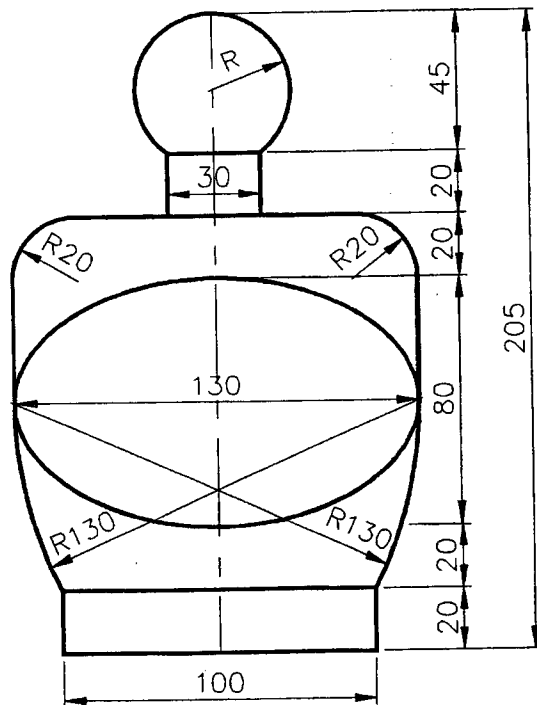

The figure shows the design of a **perfume bottle**. It has a label, in the shape of an ellipse, attached. The Major Axis is 130mm and the Minor Axis 80mm. Draw the given design showing clearly all construction lines.

3

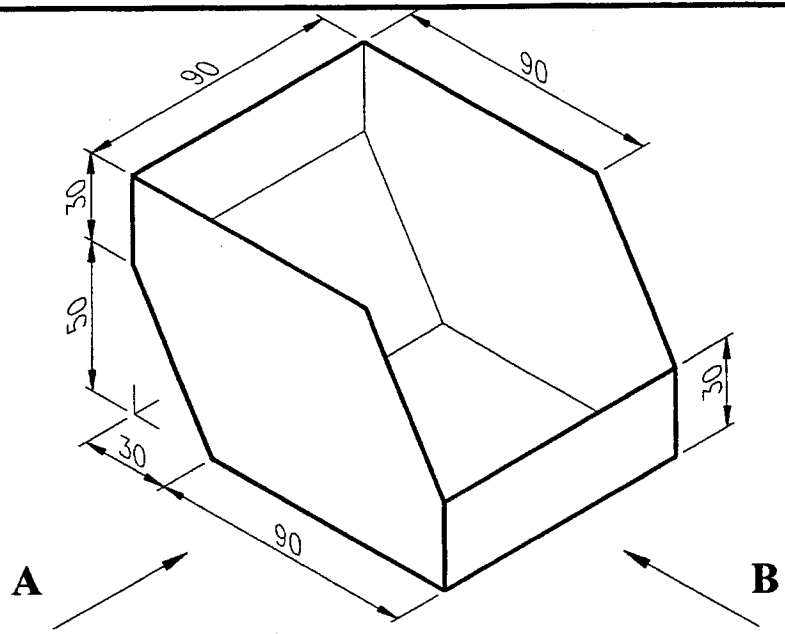

The figure shows the outline of a storage box.  
 Draw the following views :  
 (a) A front elevation looking in the direction of arrow A.  
 (b) An end elevation looking in the direction of arrow B.  
 (c) The complete **surface development** of the storage box.

4

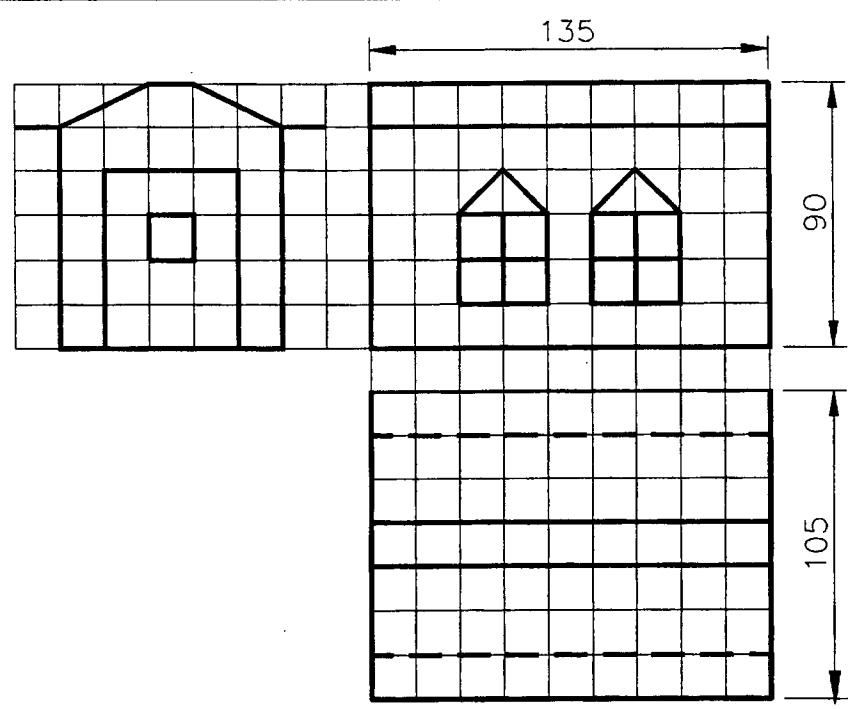

The elevation, plan and end view of a **garden shed** are shown. The grid is made up of 15mm squares.  
 Draw one of the following views :  
 (a) An **isometric** view **or** (b) An **oblique** view of the garden shed  
**The solution must be presented on standard drawing paper.**

5

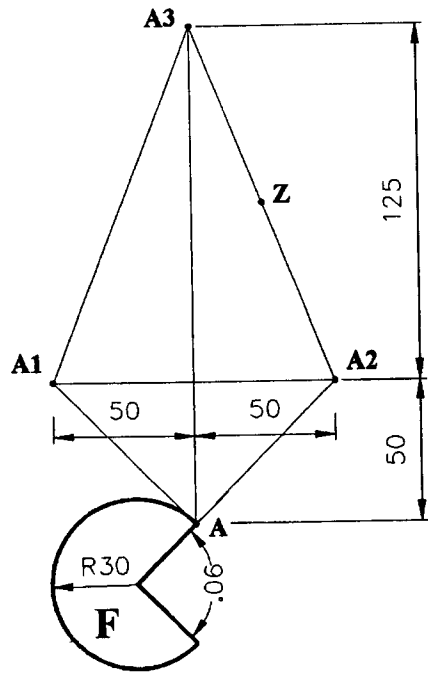

Draw the given figure F. Then locate the points A1, A2, A3 and Z.  
 Find the image of the given figure F under the following transformations :-  
 (a) From point A to A1 by a **translation**,  
 (b) From point A1 to A2 by an **axial symmetry** in the line A — A3,  
 (c) From point A2 to A3 by a **central symmetry** in the point Z.

6

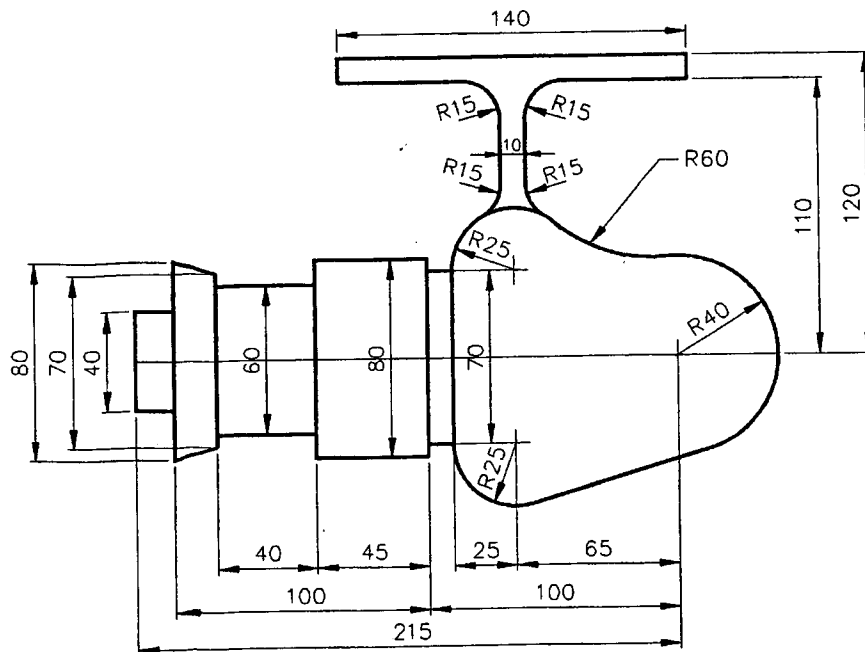

A design for a **fishing reel** is shown. Reproduce the given figure, showing clearly all constructions and points of contact.