

ISTQB® Certified Tester
Foundation Level PRACTICE EXAM

Name: _____

Company address: _____

Phone : _____

Fax : _____

Email: _____

Billing address: _____

Training company: _____

Trainer: _____

Foundation Level PRACTICE EXAM

Syllabus Version 2010
Practice Exam Version 2011

ISTQB® Certified Tester Foundation Level

ISTQB® Certified Tester Foundation Level

Introduction

This is a Sample Exam. The objective is helping the candidates in their preparation for the real examination. It provides a set of questions whose format is similar to the full ISTQB Certified Tester Foundation Level REAL exam.

It is strictly forbidden to use these exam questions in a LIVE EXAM.

- 1) Any individual or training company may use this Practice Exam in a training course if ISTQB is acknowledged as the source and copyright owner of the Practice Exam.
- 2) Any individual or group of individuals may use this Practice Exam as the basis for articles, books, or other derivative writings if ISTQB is acknowledged as the source and copyright owner of the practice exam.
- 3) Any ISTQB-recognized National Board may translate this Practice Exam and make it publicly available if ISTQB is acknowledged as the source and copyright owner of the practice exam.

Questions
"Fundamentals of testing"

1. Which of the following statements BEST describes one of the seven key principles of software testing? [K1]
- a) **Automated tests are better than manual tests for avoiding the Exhaustive Testing.**
 - b) **Exhaustive testing is, with sufficient effort and tool support, feasible for all software.**
 - c) **It is normally impossible to test all input / output combinations for a software system.**
 - d) **The purpose of testing is to demonstrate the absence of defects.**
2. Which of the following statements is the MOST valid goal for a test team? [K1]
- a) **Determine whether enough component testing was executed.**
 - b) **Cause as many failures as possible so that faults can be identified and corrected.**
 - c) **Prove that all faults are identified.**
 - d) **Prove that any remaining faults will not cause any failures.**

ISTQB® Certified Tester Foundation Level

3. Which of these tasks would you expect to perform during Test Analysis and Design? [1]
- a) **Setting or defining test objectives.**
 - b) **Reviewing the test basis.**
 - c) **Creating test suites from test procedures.**
 - d) **Analyzing lessons learned for process improvement.**
4. Below is a list of problems that can be observed during testing or operation. Which is MOST likely a failure? [K2]
- a) **The product crashed when the user selected an option in a dialog box.**
 - b) **One source code file included in the build was the wrong version.**
 - c) **The computation algorithm used the wrong input variables.**
 - d) **The developer misinterpreted the requirement for the algorithm.**
5. Which of the following, if observed in reviews and tests, would lead to problems (or conflict) within teams? [K1]
- a) **Testers and reviewers are not curious enough to find defects.**
 - b) **Testers and reviewers are not qualified enough to find failures and faults.**
 - c) **Testers and reviewers communicate defects as criticism against persons and not against the software product.**
 - d) **Testers and reviewers expect that defects in the software product have already been found and fixed by the developers.**

6. Which of the following statements are TRUE? [1]
- A. Software testing may be required to meet legal or contractual requirements.
 - B. Software testing is mainly needed to improve the quality of the developer's work.
 - C. Rigorous testing and fixing of defects found can help reduce the risk of problems occurring in an operational environment.
 - D. Rigorous testing is sometimes used to prove that all failures have been found.
- a) **B and C are true; A and D are false.**
- b) **A and D are true; B and C are false.**
- c) **A and C are true, B and D are false.**
- d) **C and D are true, A and B are false.**
7. Which of the following statements BEST describes the difference between [K2] testing and debugging?
- a) **Testing pinpoints (identifies the source of) the defects. Debugging analyzes the faults and proposes prevention activities.**
- b) **Dynamic testing shows failures caused by defects. Debugging finds, analyzes, and removes the causes of failures in the software.**
- c) **Testing removes faults. Debugging identifies the causes of failures.**
- d) **Dynamic testing prevents causes of failures. Debugging removes the failures.**

Questions**"Testing throughout the software life cycle"**

8. Which statement below BEST describes non-functional testing? [K1]
- a) **The process of testing an integrated system to verify that it meets specified requirements.**
 - b) **The process of testing to determine the compliance of a system to coding standards.**
 - c) **Testing without reference to the internal structure of a system.**
 - d) **Testing system attributes, such as usability, reliability or maintainability.**
9. What is important to do when working with software development models? [K1]
- a) **To adapt the models to the context of project and product characteristics.**
 - b) **To choose the waterfall model because it is the first and best proven model.**
 - c) **To start with the V-model and then move to either iterative or incremental models.**
 - d) **To only change the organization to fit the model and not vice versa.**

10. Which of the following characteristics of good testing apply to any software development life cycle model? [K1]
- a) **Acceptance testing is always the final test level to be applied.**
 - b) **All test levels are planned and completed for each developed feature.**
 - c) **Testers are involved as soon as the first piece of code can be executed.**
 - d) **For every development activity there is a corresponding testing activity.**
11. For which of the following would maintenance testing be used? [K1]
- a) **Correction of defects during the development phase.**
 - b) **Planned enhancements to an existing operational system.**
 - c) **Complaints about system quality during user acceptance testing.**
 - d) **Integrating functions during the development of a new system.**
12. Which of the following statements are TRUE? [K2]
- A. Regression testing and acceptance testing are the same.
 - B. Regression tests show if all defects have been resolved.
 - C. Regression tests are typically well-suited for test automation.
 - D. Regression tests are performed to find out if code changes have introduced or uncovered defects.
 - E. Regression tests should be performed in integration testing.
- a) **A, C and D and E are true; B is false.**
 - b) **A, C and E are true; B and D are false.**
 - c) **C and D are true; A, B and E are false.**
 - d) **B and E are true; A, C and D are false.**

13. Which of the following comparisons of component testing and system testing are TRUE? [K2]
- a) **Component testing verifies the functioning of software modules, program objects, and classes that are separately testable, whereas system testing verifies interfaces between components and interactions with different parts of the system.**
 - b) **Test cases for component testing are usually derived from component specifications, design specifications, or data models, whereas test cases for system testing are usually derived from requirement specifications, functional specifications or use cases.**
 - c) **Component testing focuses on functional characteristics, whereas system testing focuses on functional and non-functional characteristics.**
 - d) **Component testing is the responsibility of the technical testers, whereas system testing typically is the responsibility of the users of the system.**

Questions
"Static techniques"

14. Which of the following are the main phases of a formal review? [K1]
- a) **Initiation, status, preparation, review meeting, rework, follow up.**
 - b) **Planning, preparation, review meeting, rework, closure, follow up.**
 - c) **Planning, kick off, individual preparation, review meeting, rework, follow up.**
 - d) **Preparation, review meeting, rework, closure, follow up, root cause analysis.**
15. Which TWO of the review types below are the BEST fitted (most adequate) options to choose for reviewing safety critical components in a software project? [K2]
- Select 2 options.
- a) **Informal review.**
 - b) **Management review.**
 - c) **Inspection.**
 - d) **Walkthrough.**
 - e) **Technical Review.**

16. Which of the following statements about static analysis is FALSE? [K1]
- a) **Static analysis can be used as a preventive measure with appropriate process in place.**
 - b) **Static analysis can find defects that are not easily found by dynamic testing.**
 - c) **Static analysis can result in cost savings by finding defects early.**
 - d) **Static analysis is a good way to force failures into the software.**

PRACTICE EXAM

ISTQB® Certified Tester Foundation Level

Questions
"Test design techniques"

17. One of the test goals for the project is to have 100% decision coverage. The following three tests have been executed for the control flow graph shown below. [K4]

- Test A covers path: A, B, D, E, G.
- Test B covers path: A, B, D, E, F, G.
- Test C covers path: A, C, F, C, F, C, F, G.

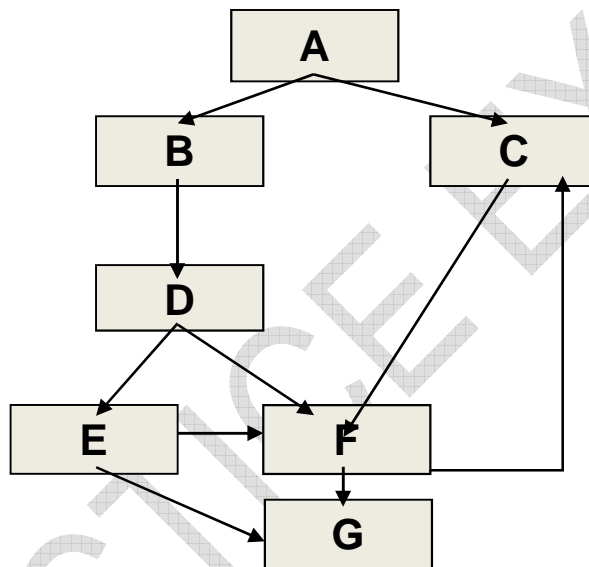

Which of the following statements related to the decision coverage goal is correct?

- a) **Decision D has not been tested completely.**
- b) **100% decision coverage has been achieved.**
- c) **Decision E has not been tested completely.**
- d) **Decision F has not been tested completely.**

18. A defect was found during testing. When the network got disconnected while receiving data from a server, the system crashed. The defect was fixed by correcting the code that checked the network availability during data transfer. The existing test cases covered 100% of all statements of the corresponding module. To verify the fix and ensure more extensive coverage, some new tests were designed and added to the test suite.

What types of testing are mentioned above?

- A. Functional testing.
- B. Structural testing.
- C. Re-testing.
- D. Performance testing.

- a) **A, B and D.**
- b) **A and C.**
- c) **A, B and C.**
- d) **A, C and D.**

-
-
-
-

PRACTICE EXAM

19. Which of the following statements about the given state table is TRUE?

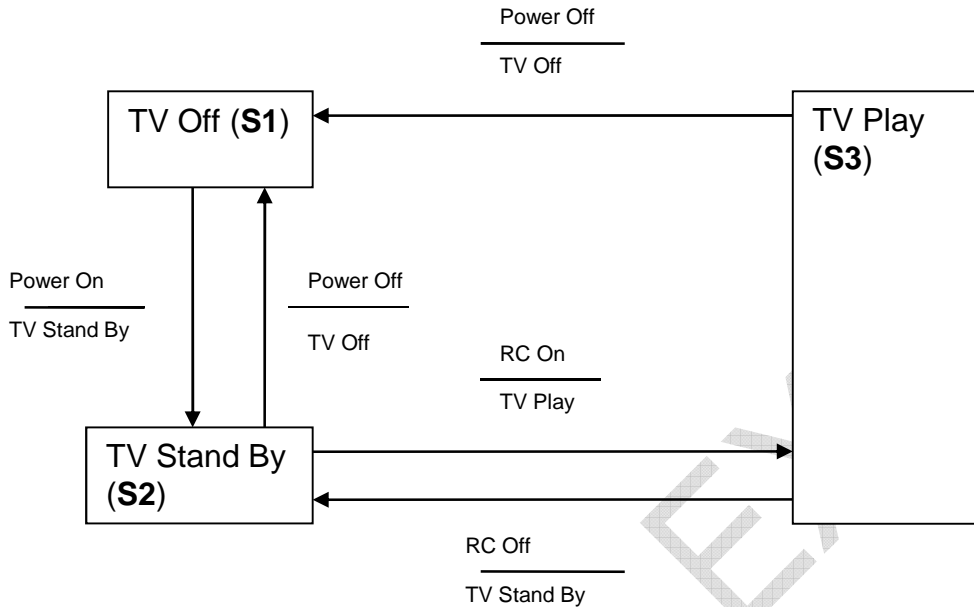

Test case	1	2	3	4	5
Start state	S1	S2	S2	S3	S3
Input	Power On	Power Off	RC On	RC Off	Power Off
Expected output	TV Stand By	TV Off	TV Play	TV Stand By	TV Off
Finish State	S2	S1	S3	S2	S1

- a) The state table can be used to derive both valid and invalid transitions.
- b) The state table represents all possible single transitions.
- c) The state table represents only some of all possible single transitions.
- d) The state table represents sequential pairs of transitions.

ISTQB® Certified Tester Foundation Level

20. Which of the following statements are true for the equivalence partitioning test technique? [1]
- A. Divides possible inputs into classes that have the same behaviour.
 - B. Uses both valid and invalid partitions.
 - C. Makes use only of valid partitions.
 - D. Must include at least two values from every equivalence partition.
 - E. Can be used only for testing equivalence partitions inputs from a Graphical User Interface.
- a) **A, B and E are true; C and D are false.**
- b) **A, C and D are true; B and E are false.**
- c) **A and E are true; B, C and D are false.**
- d) **A and B are true; C, D and E are false.**
21. Which TWO of the following solutions below lists techniques that can all be categorized as Black Box design techniques? [K1]
- Select 2 options.
- a) **Equivalence Partitioning, decision tables, state transition, and boundary value.**
- b) **Equivalence Partitioning, decision tables, use case.**
- c) **Equivalence Partitioning, decision tables, checklist based, statement coverage, use case.**
- d) **Equivalence Partitioning, cause-effect graph, checklist based, decision coverage, use case.**
- e) **Equivalence Partitioning, cause-effect graph, checklist based, decision coverage and boundary value.**

22. An employee's bonus is to be calculated. It cannot become negative, but it can be calculated to zero. The bonus is based on the duration of the employment. An employee can be employed for less than or equal to 2 years, more than 2 years but less than 5 years, 5 to 10 years, or longer than 10 years. Depending on this period of employment, an employee will get either no bonus or a bonus of 10%, 25% or 35%. [K3]

How many equivalence partitions are needed to test the calculation of the bonus?

- a) **3.**
- b) **5.**
- c) **2.**
- d) **4.**

23. Which of the following statements about the benefits of deriving test cases from use cases are most likely to be true? [K2]

- A. Deriving test cases from use cases is helpful for system and acceptance testing.
- B. Deriving test cases from use cases is helpful only for automated testing.
- C. Deriving test cases from use cases is helpful for component testing.
- D. Deriving test cases from use cases is helpful for testing the interaction between different components of the system.

- a) **A and D are true; B and C are false.**
- b) **A is true; B, C and D are false.**
- c) **A and B are true; C and D are false.**
- d) **C is true; A, B and D are false.**

24. Which of the below would be the best basis for fault attack testing? [K1]
- a) **Experience, defect and failure data, knowledge about software failures.**
 - b) **Risk analysis performed at the beginning of the project.**
 - c) **Use Cases derived from the business flows by domain experts.**
 - d) **Expected results from comparison with an existing system.**
25. Which of the following would be the best test approach when there are poor specifications and time pressures? [K1]
- a) **Use Case Testing.**
 - b) **Condition Coverage.**
 - c) **Exploratory Testing.**
 - d) **Path Testing.**
26. Which one of the following techniques is structure-based? [K1]
- a) **Decision testing.**
 - b) **Boundary value analysis.**
 - c) **Equivalence partitioning.**
 - d) **State transition testing.**

ISTQB® Certified Tester Foundation Level

27. You have started specification-based testing of a program. It calculates the greatest common divisor (GCD) of two integers (A and B) greater than zero.

calcGCD (A, B);

The following test cases (TC) have been specified.

TC	A	B
1	1	1
2	INT_MAX	INT_MAX
3	1	0
4	0	1
5	INT_MAX+1	1
6	1	INT_MAX+1

INT_MAX: largest Integer

Which test technique has been applied in order to determine test cases 1 through 6?

- a) **Boundary value analysis.**
- b) **State transition testing.**
- c) **Equivalence partitioning.**
- d) **Decision table testing.**

28. Consider the following state transition diagram and test case table:

[K3]

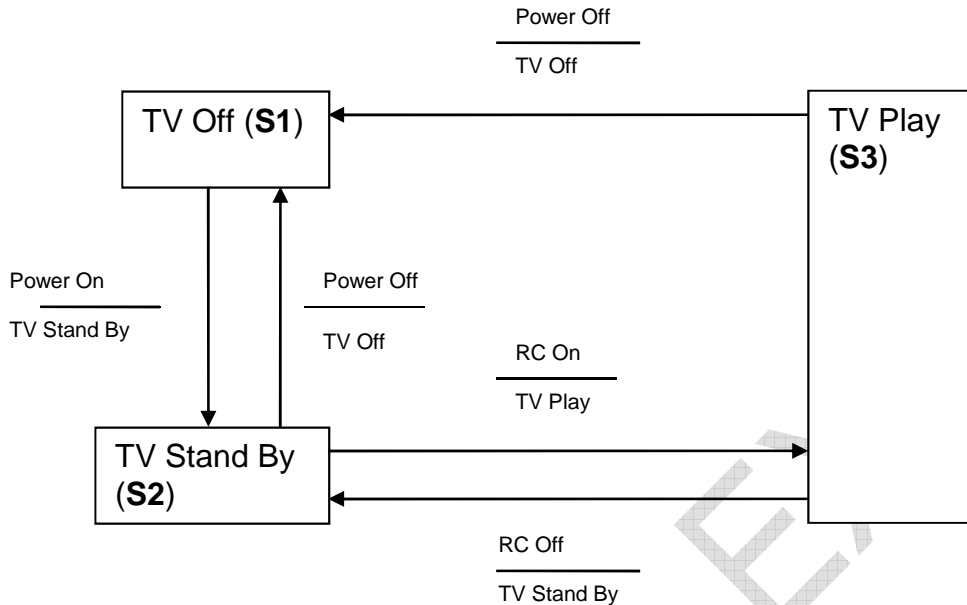

Test Case	1	2	3	4	5	6	7
Start state	S1	S1	S2	S2	S3	S3	S3
Input	Press Power On	Press Power On	Press RC On	Press RC On	Press RC Off	Press Power Off	Press RC Off
Expected Output	TV Stand By	TV Stand By	TV Play	TV Play	TV Stand By	TV OFF	TV Stand By
Next state	S2	S2	S3	S3	S2	S1	S2
Input	Press Power Off	Press RC On	Press Power Off	Press RC Off	Press RC On	Press Power On	Press Power Off
Expected Output	TV Off	TV Play	TV Off	TV Stand By	TV Play	TV Stand By	TV Off
Finish state	S1	S3	S1	S2	S3	S2	S1

Which of the following statements are TRUE?

- A. The test case table exercises the shortest number of transitions.
- B. The test case gives only the valid state transitions.
- C. The test case gives only the invalid state transitions.
- D. The test case exercises the longest number of transitions.

- a) **Only A is true; B, C and D are false.**
- b) **Only B is true; A, C and D are false.**
- c) **A and D are true; B, C are false.**
- d) **Only C is true; A, B and D are false.**

PRACTICE EXAM

Questions
"Test management"

29. Which of the following best describes the task partition between test manager and tester? [K1]
- a) **The test manager plans testing activities and chooses the standards to be followed, while the tester chooses the tools and controls to be used.**
 - b) **The test manager plans, organizes and controls the testing activities, while the tester specifies, automates and executes tests.**
 - c) **The test manager plans, monitors and controls the testing activities, while the tester designs tests.**
 - d) **The test manager plans and organizes the testing and specifies the test cases, while the tester prioritizes and executes the tests.**
30. Which of the following can be categorized as product risks? [K2]
- a) **Low quality of requirements, design, code and tests.**
 - b) **Political problems and delays in especially complex areas in the product.**
 - c) **Error-prone areas, potential harm to the user, poor product characteristics.**
 - d) **Problems in defining the right requirements, potential failure areas in the software or system.**

31. Which of the following are typical test exit criteria? [K2]
- a) **Thoroughness measures, reliability measures, test cost, schedule, state of defect correction and residual risks.**
 - b) **Thoroughness measures, reliability measures, degree of tester independence and product completeness.**
 - c) **Thoroughness measures, reliability measures, test cost, time to market and product completeness, availability of testable code.**
 - d) **Time to market, residual defects, tester qualification, degree of tester independence, thoroughness measures and test cost.**

32. As a Test Manager you have the following requirements to be tested:

Requirements to test:

- R1 - Process Anomalies – High Complexity
- R2 - Remote Services – Medium Complexity
- R3 – Synchronization – Medium Complexity
- R4 – Confirmation – Medium Complexity
- R5 - Process closures – Low Complexity
- R6 – Issues – Low Complexity
- R7 - Financial Data – Low Complexity
- R8 - Diagram Data – Low Complexity
- R9 - Changes on user profile – Medium Complexity

Requirements logical dependencies (A -> B means that B is dependent on A):

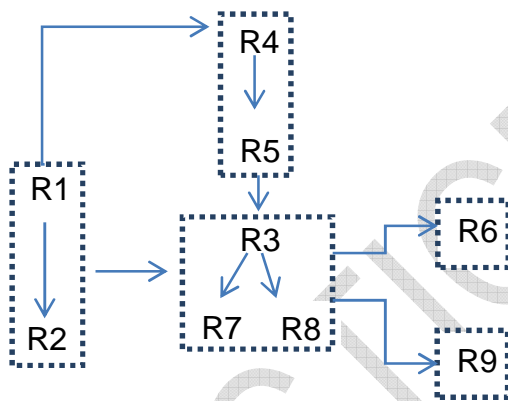

How would you structure the test execution schedule according to the requirement dependencies?

- a) R4 > R5 > R1 > R2 > R3 > R7 > R8 > R6 > R9.
- b) R1 > R2 > R3 > R4 > R5 > R7 > R8 > R6 > R9.
- c) R1 > R2 > R4 > R5 > R3 > R7 > R8 > R6 > R9.
- d) R1 > R2 > R3 > R7 > R8 > R4 > R5 > R6 > R9.

33. What is the benefit of independent testing? [K1]
- a) **More work gets done because testers do not disturb the developers all the time.**
 - b) **Independent testers tend to be unbiased and find different defects than the developers.**
 - c) **Independent testers do not need extra education and training.**
 - d) **Independent testers reduce the bottleneck in the incident management process.**
34. Which of the following would be categorized as project risks? [K1]
- a) **Skill and staff shortages.**
 - b) **Poor software characteristics.**
 - c) **Failure-prone software delivered.**
 - d) **Possible reliability defect (bug).**
35. As a test manager you are asked for a test summary report. Concerning test activities and according to IEEE 829 Standard, what should you consider in your report? [K2]
- a) **The number of test cases using Black Box techniques.**
 - b) **A summary of the major testing activities, events and its status in respect of meeting goals.**
 - c) **Overall evaluation of each development work item.**
 - d) **Training taken by members of the test team to support the test effort.**

36. You are a tester in a safety-critical software development project. During execution of a test, you find out that one of your expected results was not achieved. You write an incident report about it. What do you consider to be the most important information to include according to the IEEE Std. 829? [K3]
- a) **Impact, incident description, date and time, your name.**
 - b) **Unique id for the report, special requirements needed.**
 - c) **Transmitted items, your name and you're feeling about the defect source.**
 - d) **Incident description, environment, expected results.**

PRACTICE EXAM

ISTQB® Certified Tester Foundation Level

Questions**"Tool support for testing"**

37. From the list below, select the recommended principles for introducing a chosen test tool in an organization? [K1]

1. Roll the tool out to the entire organization at the same time.
2. Start with a pilot project.
3. Adapt and improve processes to fit the use of the tool.
4. Provide training and coaching for new users.
5. Let each team decide their own standard ways of using the tool.
6. Monitor that costs do not exceed initial acquisition cost.
7. Gather lessons learned from all teams.

- a) 1, 2, 3, 5.
- b) 1, 4, 6, 7.
- c) 2, 3, 4, 7.
- d) 3, 4, 5, 6.

38. Which one of the following best describes a characteristic of a keyword-driven test execution tool? [K1]
- a) **A table with test input data, action words, and expected results, controls execution of the system under test.**
 - b) **Actions of testers recorded in a script that is rerun several times.**
 - c) **Actions of testers recorded in a script that is run with several sets of test input data.**
 - d) **The ability to log test results and compare them against the expected results, stored in a text file.**
39. Which of the following is NOT a goal of a Pilot Project for tool evaluation? [K1]
- a) **To evaluate how the tool fits with existing processes and practices.**
 - b) **To determine use, management, storage, and maintenance of the tool and test assets.**
 - c) **To assess whether the benefits will be achieved at reasonable cost.**
 - d) **To reduce the defect rate in the Pilot Project.**

40. Below is a list of test efficiency improvement goals a software development and test organization would like to achieve. [K2]

Which of these goals would best be supported by a test management tool?

- a) **To build traceability between requirements, tests, and bugs.**
- b) **To optimize the ability of tests to identify failures.**
- c) **To resolve defects faster.**
- d) **To automate selection of test cases for execution.**

PRACTICE EXAM