

# Chartered Membership Examination



Thursday 3 APRIL 2008

---

## Structural Engineering Design and Practice

9.30a.m. – 1p.m. and 1.30 – 5p.m. (Discussion between individuals is not permitted during lunch period).

A period of fifteen minutes is provided for reading the question paper, immediately before the commencement of the examination. Candidates are not permitted to write in answer sheets, or on drawing paper or to use a calculator during this time.

Candidates must satisfy the Examiners in ONE question.

### Important

The written answer to the question selected and any A3 drawings must bear the candidate's number and the question number at the bottom of the page. Only the answer sheets supplied by the Institution may be used. The candidate's name should not appear anywhere in the script.

### Notes to Candidates

1. TO PASS THE EXAMINATION, CANDIDATES MUST SATISFY THE EXAMINERS IN BOTH PARTS OF THE QUESTION ATTEMPTED.
2. Examiners will only mark work written by hand during the examination.
3. A fair proportion of marks will be awarded for the demonstration of an understanding of fundamental engineering concepts, as distinct from calculation of member forces and sizes. NOTE: In the calculation part of all questions, establishing "form and size" is taken to mean compliance with all relevant design criteria, i.e. bending, shear, deflection, etc.
4. In all questions 50 marks are allocated to Section 1 and 50 marks to Section 2.
5. The Examiners are looking for sound structural designs. It should also be remembered that aesthetics, economy and function are important in any competent engineering scheme.
6. Any assumptions made and the design data and criteria adopted must be stated.
7. Portable computers or programmable calculators may be used but sufficient calculations must be submitted to substantiate the design, and these should be set out as in practice.
8. Good clear drawings and sketches are required; they should show all salient and structural features to suitable scales and should incorporate adequate details.
9. Candidates will not be allowed to include any previously prepared calculations, notes, sketches, diagrams, computer output or other similar material in their answer sheets or A3 drawings. Any previously prepared information submitted by candidates will be ignored by the examiners.
10. Strictly no external electronic contact is allowed between a candidate and anyone outside the examination venue. Mobile phones must be switched off throughout the duration of the examination.
11. This paper is set in IMPERIAL Units.

*Now read 'Reminder' on page 3*



## **Chartered membership Examination, a reminder from your Examiners**

The work you are about to start has many features in common with other examinations which you have tackled successfully but it also has some which are unusual.

As in every examination you must follow carefully the NOTES FOR CANDIDATES set out for your guidance on the front cover of this paper; allocate the available time sensibly and set out your work in a logical and clear way.

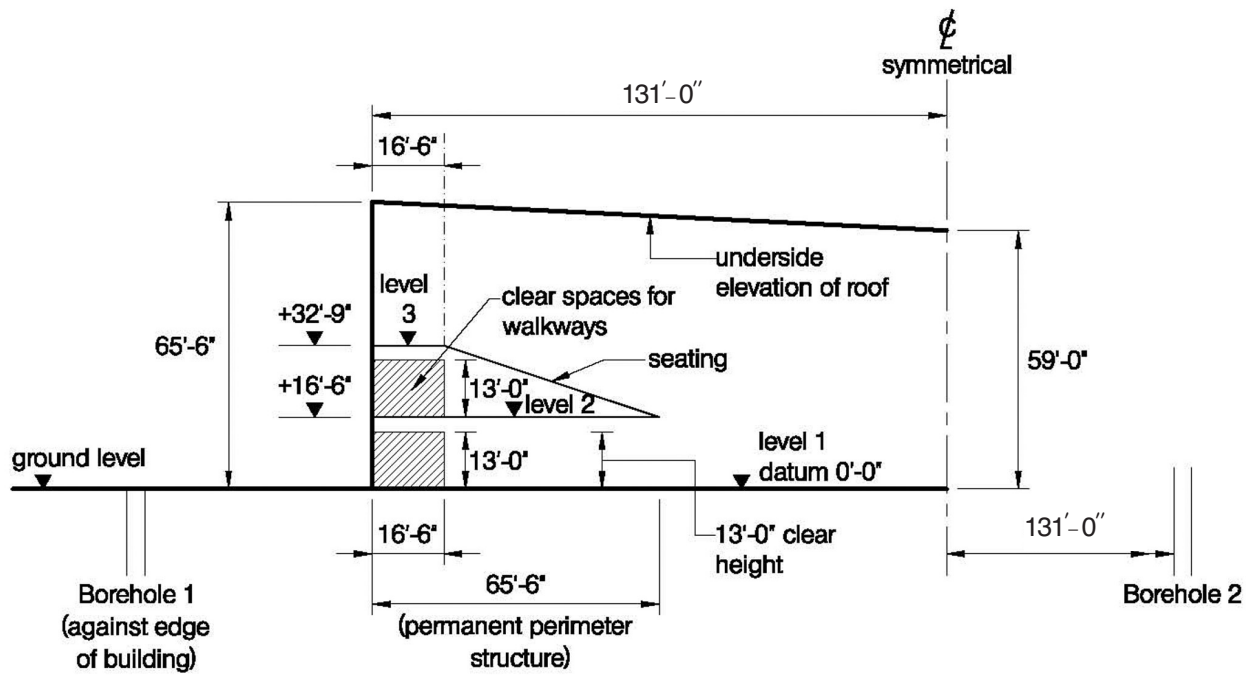
The unusual requirement of the examination is that you demonstrate the validity of the training and experience that you have acquired in recent years. The Institution must be satisfied that you are able to bring all the various skills you are expected to possess to the effective solution of structural design problems – whether or not the problem is presented in terms that are within your actual experience.

Chartered Structural Engineers must have the ability to design and a facility to communicate their design intentions. Where you are required to list and discuss possible structural solutions you must show by brief, clear, logical and systematic presentation that you understood the general structural engineering principles involved.

In selecting and developing your design you should also remember the guidance given in the Institution's report, Aims of Structural Design, and in particular:

- (1) “the structure must be safe”,
- (2) “a good design has certain typical features – simplicity, unity and necessity”,
- (3) “the structure must fulfil its intended function”.

If you have difficulty in deciding the correct interpretation of a question, pay particular attention to point 6. notes to candidates, on the front cover. The examiners will take into account your interpretation – and the design you base on this – if this is clearly stated at the beginning of your answer.



TYPICAL SECTION THROUGH ARENA

NOTE: All dimensions are in feet and inches

FIGURE Q1

# Question 1. Sports Arena

## Client's requirements

1. A circular sports arena is to be built on a vacant site; see Figure Q1.
2. The Client has specified that the building shall be 262'0" in diameter internally. The height of the underside of the roof is to be a minimum of 59'0" above the floor in the centre and 65'6" at the perimeter of the arena. The interior of the arena shall be column free.
3. The roof over the arena is to be a lightweight structure and should be of a pleasing appearance.
4. Around the perimeter of the arena is a permanent structure that supports the seating and provides accommodation at level 1 for offices and public amenities and at level 2 for storage. The seating will be made of precast concrete planks which have a maximum span of 26'3".
5. A 16'6" wide by 13'0" high clear access way is located around the perimeter of level 1 and level 2 shown shaded in Fig.Q1. The area under the sloping seating at level 2 is for storage only and there are no restrictions on the placement of structure in this area.
6. The Client wishes to retain flexibility of use within level 1 of the permanent perimeter structure and has stipulated that the area will be completely unobstructed other than for two lines of internal columns on concentric grid lines measured from the centre of the arena. A minimum spacing of 19'9" between column centres shall be maintained in all directions. A minimum clear height to underside of structure of 13'0" is required throughout. There are no limits on column spacing around the perimeter wall, which is to be clad in masonry.

## Imposed Loading

- |                      |  |
|----------------------|--|
| 7. Roof              | 12psf  |
| Floor levels 2 and 3 | 100psf   |
| Seating Area         | Precast planks dead load of 160psf and live load of 100psf |
| Floor level 1        | 400psf   |
- Loadings include an allowance for partitions, finishes, services and ceilings.

## Site Conditions

8. The site is level and located on the edge of a major city centre. The site has a public parking area on all sides. Basic wind speed is 90mph based on a 3 second gust; the equivalent mean hourly wind speed is 45mph.

### Ground conditions

Borehole 1	Ground - 7'	Made ground (fill)
	7' - 26'	Stiff clay. C=1800psf
	Below 26'	Rock. Allowable bearing pressure = 10tons/ft <sup>2</sup>
Borehole 2	Ground - 13'	Made ground
	13' - 33'	Stiff clay. C=1600psf
	Below 33'	Rock. Allowable bearing pressure = 10tons/ft <sup>2</sup>

Ground conditions change linearly between the 2 boreholes and groundwater was not encountered.

## Omit from consideration

9. Detailed design of staircase, precast seating planks and specialist finishes to level 1 floor.

*continued overleaf*



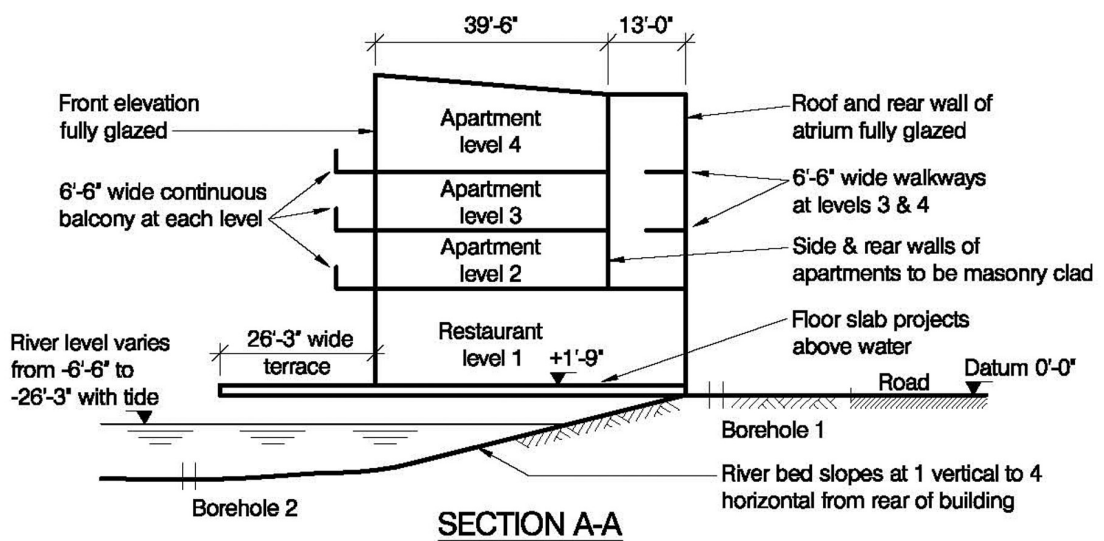
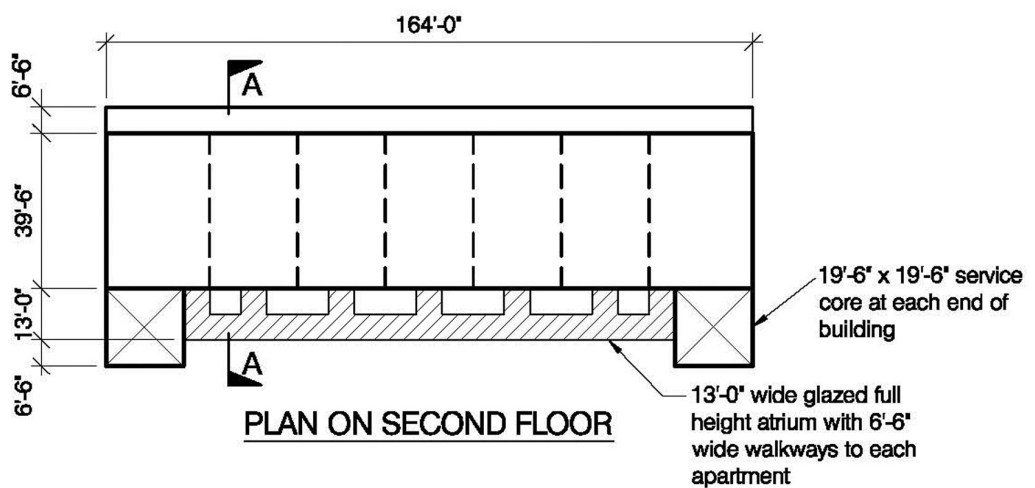
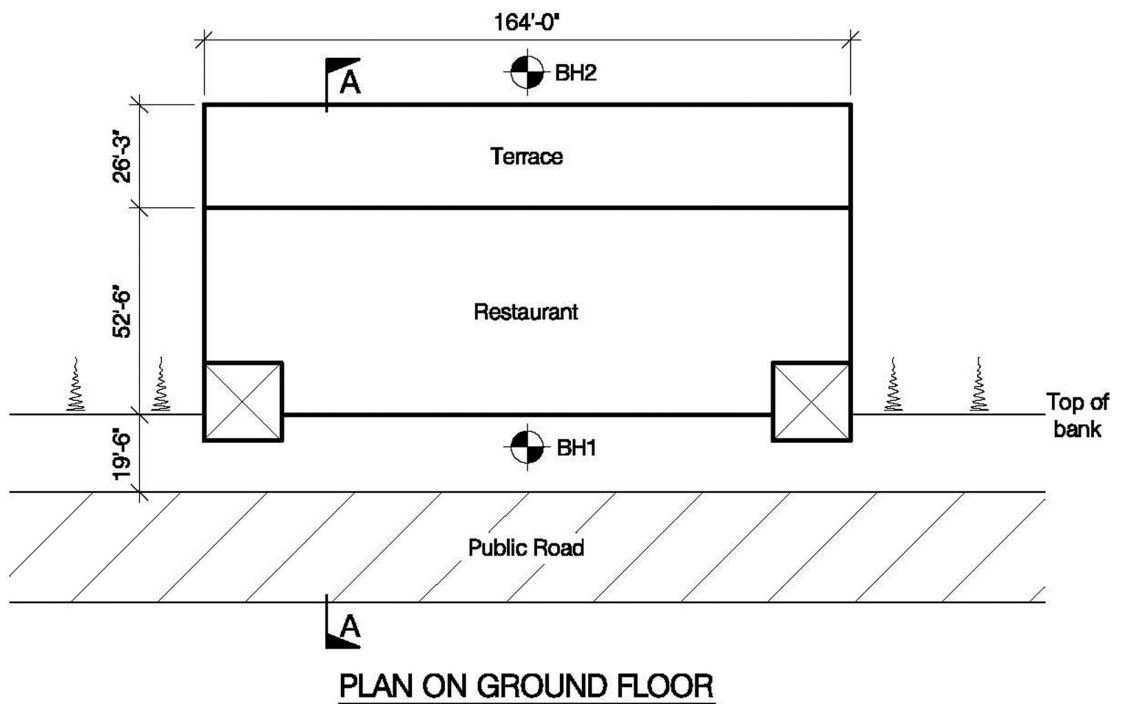
**SECTION 1****(50 marks)**

- a. Prepare a design appraisal with appropriate sketches indicating two distinct and viable solutions for the proposed structure including the foundations. Indicate clearly the functional framing, load transfer and stability aspects of each scheme. Identify the solution you recommend, giving reasons for your choice. (40 marks)
- b. After the design has been completed, the Client advises you that he wishes to hang a large advertising and lighting box weighing 50 tons from the middle of the roof. Write a letter to the Client explaining how this might be achieved. (10 marks)

**SECTION 2****(50 marks)**

For the solution recommended in Section 1(a):

- c. Prepare sufficient design calculations to establish the form and size of all the principal structural elements including the foundations. (20 marks)
- d. Prepare general arrangement plans, sections and elevations to show the dimensions, layout and disposition of the structural elements and critical details for estimating purposes. (20 marks)
- e. Prepare a detailed method statement for the safe construction of the building and an outline construction programme. (10 marks)



**NOTE:** All dimensions are in feet and inches

**FIGURE Q2**



# Question 2. Waterfront Development

## Client's requirements

1. A 4-storey residential development, with a ground floor restaurant; see Figure Q2. The development is located on the edge of a tidal river. The apartments are accessed by means of a system of elevated walkways contained within a glazed atrium which extends from level two to the roof. The entire development is to project over the river, except for the rear part of the service cores. The river level varies from 6'6" to 26'3" below ground level, depending upon the state of the tide.
2. The overall plan size of the building is 164'0" by 52'6", with an 26'3" wide terrace at level 1 extending in front of the restaurant for the full width of the building; see Figure Q2. A 6'6" wide balcony is located at floor levels 2,3 and 4. There are 7 apartments at each of the 3 upper levels, with each apartment having a minimum clear internal width of 21'3". No columns are permitted within the individual apartments and only 1 row of internal columns is permitted within the restaurant at level 1, with the level 1 internal columns being located at a minimum spacing of 26'3".
3. The front elevation of the building that faces the river is to be fully glazed. The rear and side elevations of the apartments are to be masonry clad. The roof is to be clad in metal decking.
4. Level 1 is to have a minimum clear floor to ceiling height of 11'6", with a structure-free ceiling zone of 20". Reasonable access is required beneath level 1 for inspection and maintenance and to avoid unduly impeding the river flow. The upper floors are to have a minimum clear floor to ceiling height of 8'9", with a structure-free ceiling zone of 8".
5. There is a busy public road adjacent to the site.

## Imposed Loading

6. Roof	30psf
Level 1	100psf
Upper floors, walkways and balconies	60psf
Terrace	150psf

Loadings include an allowance for partitions, finishes, services and ceilings.

## Site Conditions

7. The site is flat and is located 6 miles from the sea on the edge of a small city. Basic wind speed is 102mph based on a 3 second gust; the equivalent mean hourly wind speed is 51mph.
8. Ground conditions
 

Borehole 1	Ground -17'	Made ground (fill)
	17'-20'	Very soft silty clay. C=200psf
Borehole 2	Below 20'	Mudstone. Allowable bearing pressure = 5tons/ft <sup>2</sup>
	Riverbed-26" 3'	Very soft silts and sands. N=0. Riverbed located at 23' below site ground level.
	26' 3"-30'	Stiff clay with some gravel. C = 1600psf
	30'-36'	Mudstone. Allowable bearing pressure = 5tons/ft <sup>2</sup>
	Below 36'	Rock. Allowable bearing pressure = 15tons/ft <sup>2</sup>

Ground conditions vary linearly between the two boreholes and apply for the length of the site. The groundwater level in borehole 1 fluctuates between 6'6" and 26'3" below ground level.

## Omit from consideration

9. Detailed design of staircase and lifts within service cores.

*continued overleaf*



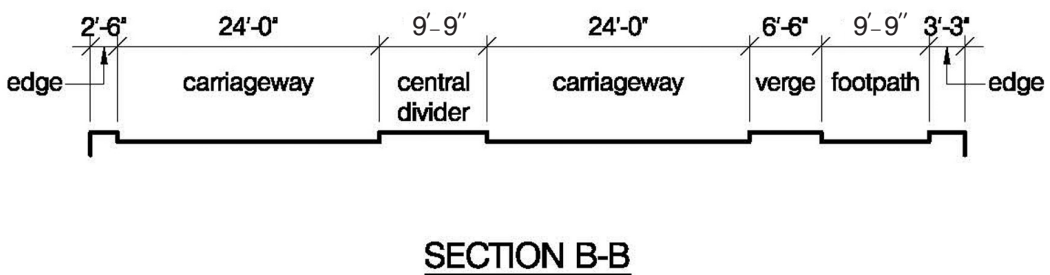
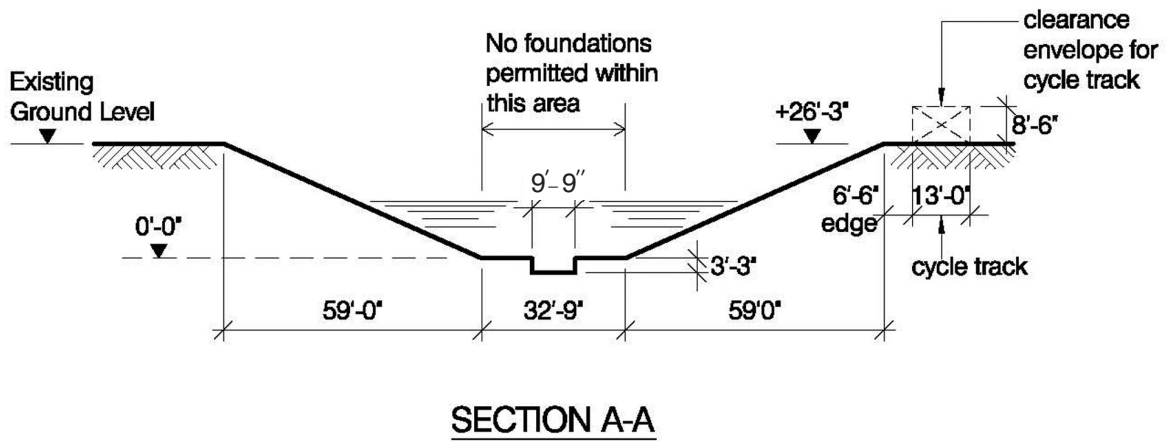
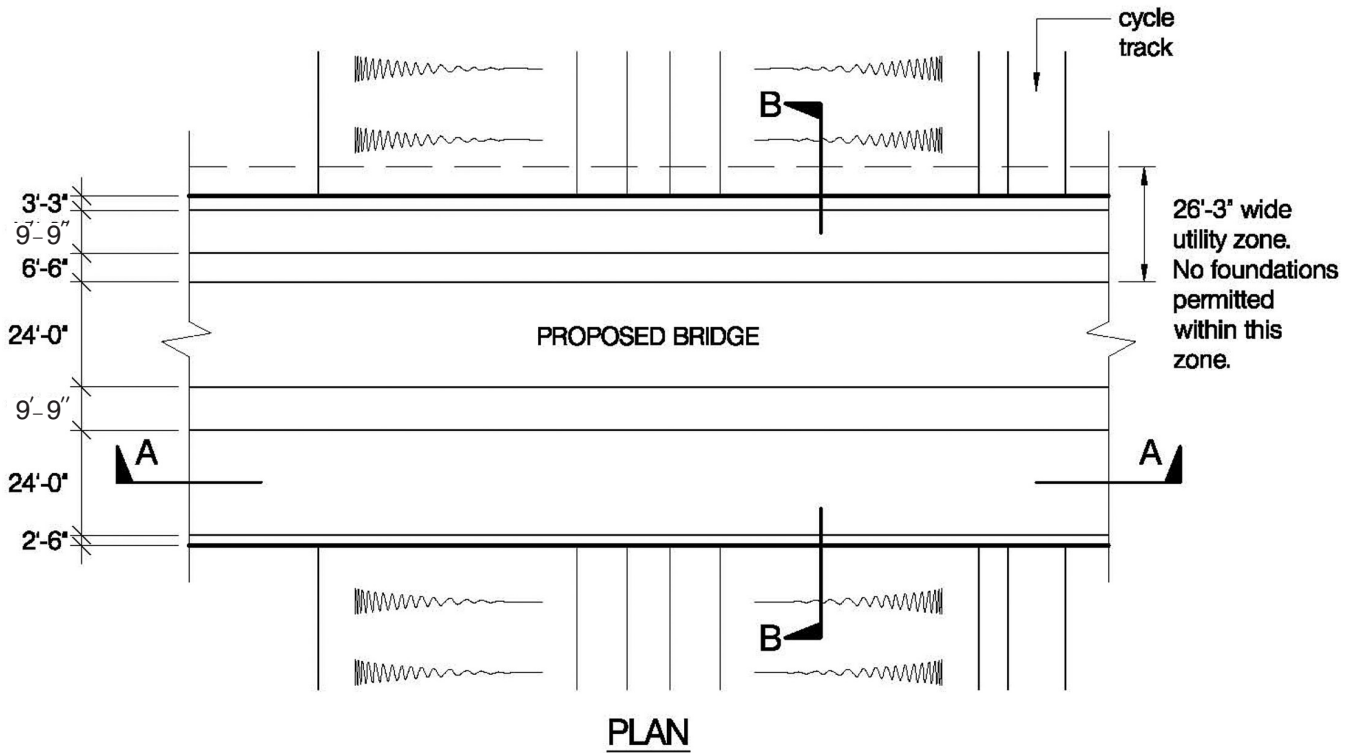
**SECTION 1****(50 marks)**

- a. Prepare a design appraisal with appropriate sketches indicating two distinct and viable solutions for the proposed structure including the foundations. Indicate clearly the functional framing, load transfer and stability aspects of each scheme. Identify the solution you recommend, giving reasons for your choice. (40 marks)
- b. After the design has been completed, the Client advises you that he wishes to add a further two levels of apartments to the development. Write a letter to the Client explaining how this might be achieved. (10 marks)

**SECTION 2****(50 marks)**

For the solution recommended in Section 1(a):

- c. Prepare sufficient design calculations to establish the form and size of all the principal structural elements including the foundations. (20 marks)
- d. Prepare general arrangement plans, sections and elevations to show the dimensions, layout and disposition of the structural elements and critical details for estimating purposes. (20 marks)
- e. Prepare a detailed method statement for the safe construction of the building and an outline construction programme. (10 marks)



**NOTE:** All dimensions are in feet and inches

**FIGURE Q3**

# Question 3. Road bridge

## Client's requirements

1. A new road bridge is required to carry a dual carriageway and footpath over an existing stormwater drainage channel and cycle track. See Figure Q3
2. No temporary nor permanent works may be placed in the drainage channel within the central zone 32' 9" wide.
3. The cycle track must be kept open at all times except from midnight to 5.00am. A clear headroom of at least 8' 6" over the cycle track is required throughout construction and on completion of the new bridge.
4. A utility zone 26' 3" wide under the bridge and across the drainage channel is required as shown in Fig. Q3, and no temporary nor permanent works are allowed within this zone.
5. Approach ramps should be kept to a minimum height with a maximum gradient of 1:12.

## Imposed Loading

- |                             |   |
|-----------------------------|---|
| 6. Vertical traffic loading | 200psf  |
| Horizontal traffic loading  | 150tons, applied parallel to the carriageways across the full width of the bridge deck. |
| Footpath loading            | 100psf  |

## Site Conditions

7. The site is located in a small town. Basic wind speed is 102mph based on a 3 second gust; the equivalent mean hourly wind speed is 51mph.
8. Ground Conditions

Ground level-2'	Made ground
2' - 39'	Sand and clay. C = 800psf
Below 39'	Rock. Allowable bearing pressure = 25tons/ft <sup>2</sup>

Ground water was encountered at 20' below ground level.

## Omit from consideration

9. Design of vehicle containment parapet.

## SECTION 1

(50 marks)

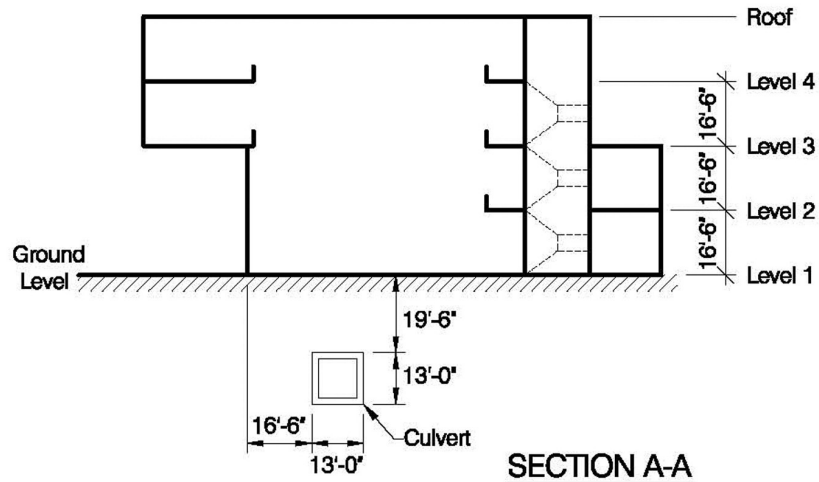
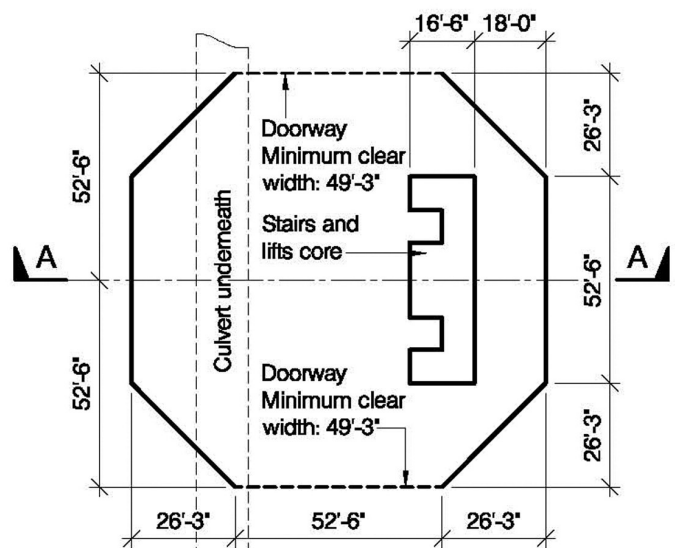
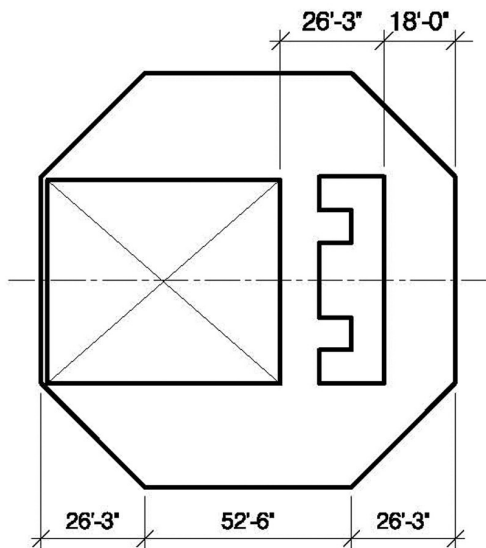
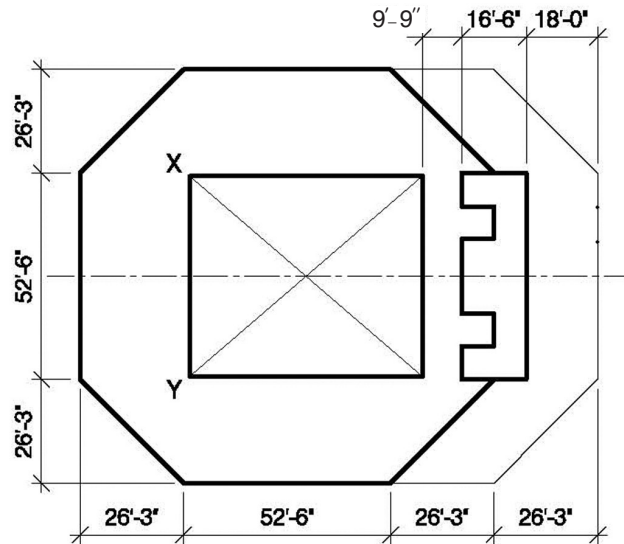
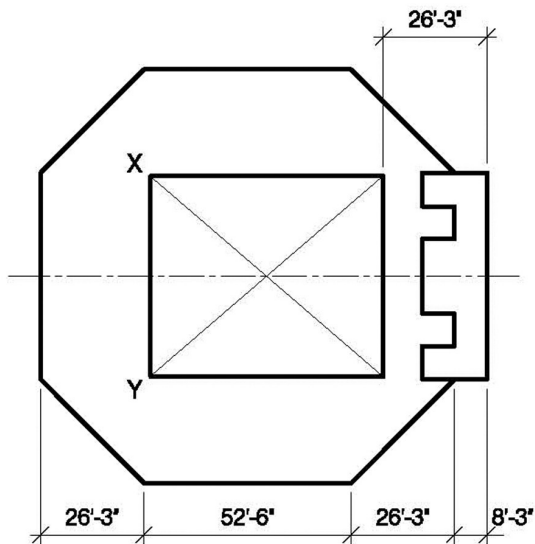
- a. Prepare a design appraisal with appropriate sketches indicating two distinct and viable solutions for the proposed structure including the foundations. Indicate clearly the functional framing, load transfer and stability aspects of each scheme. Identify the solution you recommend, giving reasons for your choice. (40 marks)
- b. After submission of your design to the statutory authority, measures to reduce traffic noise are required. It is proposed that a 6' 6"-high noise barrier made of lightweight polycarbonate sheeting should be erected on the bridge along the full length of the north side. Write a letter to your client explaining the effects of this on your design. (10 marks)

## SECTION 2

(50 marks)

For the solution recommended in Section 1(a):

- c. Prepare sufficient design calculations to establish the form and size of all the principal structural elements including the foundations. (20 marks)
- d. Prepare general arrangement plans, sections and elevations to show the dimensions, layout and disposition of the structural elements and critical details for estimating purposes. (20 marks)
- e. Prepare a detailed method statement for the safe construction of the bridge and an outline construction programme. (10 marks)



NOTE: All dimensions are in feet and inches

FIGURE Q4

# Question 4. Exhibition Hall

## Client's requirements

1. A new 4-storey exhibition hall is to be constructed: see Figure Q4.
2. The exhibition hall is to be octagonal in plan with the upper two storeys overhanging the lower two storeys. The building is to be clad in brickwork.
3. An atrium void of minimum size 59' 0" by 49' 3" is located inside the hall on levels 2, 3 and 4. An uninterrupted services zone 1' 0" deep is to be provided under each floor at levels 2, 3 and 4. All levels require a minimum clear headroom of 10' 6".
4. No internal columns are permitted between levels 1 and 3. Internal columns are permitted only at positions X and Y (see Figure Q4) on levels 3 and 4.
5. An existing box culvert runs underneath the new building. No additional loads may be imposed on the culvert and no part of the new structure, including foundations, may be closer than 3' 3" to any part of the culvert.
6. A fire resistance of 2 hours is required for all structural elements.

## Imposed loading

- |            |        |
|------------|--------|
| 7. Roof    | 30psf  |
| All floors | 100psf |

## Site conditions

8. The site is level and is located in the centre of a city 62 miles from the sea. Basic wind speed is 102mph based on a 3 second gust; the equivalent mean hourly wind speed is 51mph.
9. Ground conditions:

Ground level – 10'	Loose sand. N = 5
10' – 82'	Sand. N values vary from 10 to 80
Below 82'	Sandstone. Allowable bearing pressure = 15tons/ft <sup>2</sup>

Groundwater was not encountered.

## Omit from consideration

10. Detailed design of stairs and lift core.

## SECTION 1

(50 marks)

- a. Prepare a design appraisal with appropriate sketches indicating two distinct and viable solutions for the proposed structure including the foundations. Indicate clearly the functional framing, load transfer and stability aspects of each scheme. Identify the solution you recommend, giving reasons for your choice. (40 marks)
- b. After your recommended solution has been accepted, the Client wishes to avoid having any internal columns in the building. Write a letter to the Client explaining the effect that this would have on your proposed design. (10 marks)

## SECTION 2

(50 marks)

For the solution recommended in Section 1(a):

- c. Prepare sufficient design calculations to establish the form and size of all the principal structural elements including the foundations. (20 marks)
- d. Prepare general arrangement plans, sections and elevations to show the dimensions, layout and disposition of the structural elements and critical details for estimating purposes. (20 marks)
- e. Prepare a detailed method statement for the safe construction of the building and an outline construction programme. (10 marks)

*There is no Figure Q5*



# Question 5. Crocodile Tank

## Client's requirements

1. A tank is required at a wildlife centre to accommodate crocodiles. The plan area of the tank is to be between 38750 sq feet and 43000 sq feet and the smallest plan dimension must be at least 131'0". The tank must be of concrete construction and should be 6'6" deep generally, reducing to 3'3" at the perimeter. The tank will normally be filled with water but should be capable of being completely drained for maintenance.
2. Three "islands" are required in the tank, on which crocodiles may roam. Each island must be of minimum plan area 540 sq feet and the combined plan area of the islands must not exceed 3230 sq feet. Islands must be a minimum clear distance of 49'0" from the tank perimeter and a minimum clear distance of 49'0" apart. The ground surface around the perimeter of each island is to be at water level and must rise to at least 1'6" above water level. Structures may be supported on the islands but no structural supports of any kind are permitted elsewhere in the tank.
3. An observation tower is to be provided on one of the islands. The tower should have viewing platforms at 13'0" and 26'0" above water level. Each platform should have a plan area of at least 110 sq feet.
4. Pedestrian access of minimum unobstructed width 6'6" is to be provided from the perimeter of the tank to the observation tower.

## Imposed loading

5. Pedestrian access and viewing platforms 100psf

## Site Conditions

6. The site is level and is located in open country. Basic wind speed is 102mph based on a 3 second gust; the equivalent mean hourly wind speed is 51mph.
7. Ground conditions:  
Ground level – 13' Sand, N=18  
Below 13' Clay, C=2000psf  
Ground water was encountered at 3'3" below ground level

## SECTION 1

(50 marks)

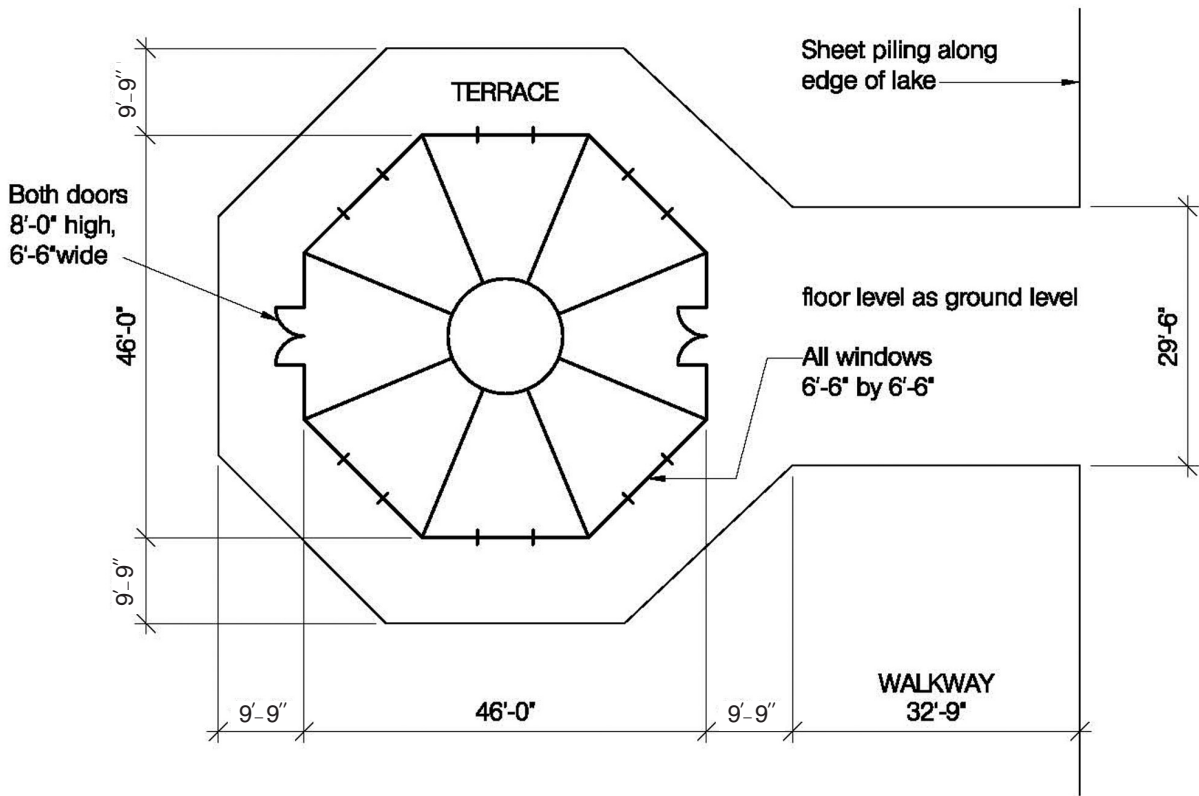
- a. Prepare a design appraisal with appropriate sketches indicating two distinct and viable solutions for the proposed tank, observation tower and pedestrian access. Indicate clearly the functional framing, load transfer and stability aspects of each scheme. Identify the solution you recommend, giving reasons for your choice. (40 marks)
- b. During construction of the tank it is found that test results for concrete used in a section of the tank including the base and walls have achieved only 70% of the required design strength. Write a letter to the Client describing your proposals for dealing with this problem. (10 marks)

## SECTION 2

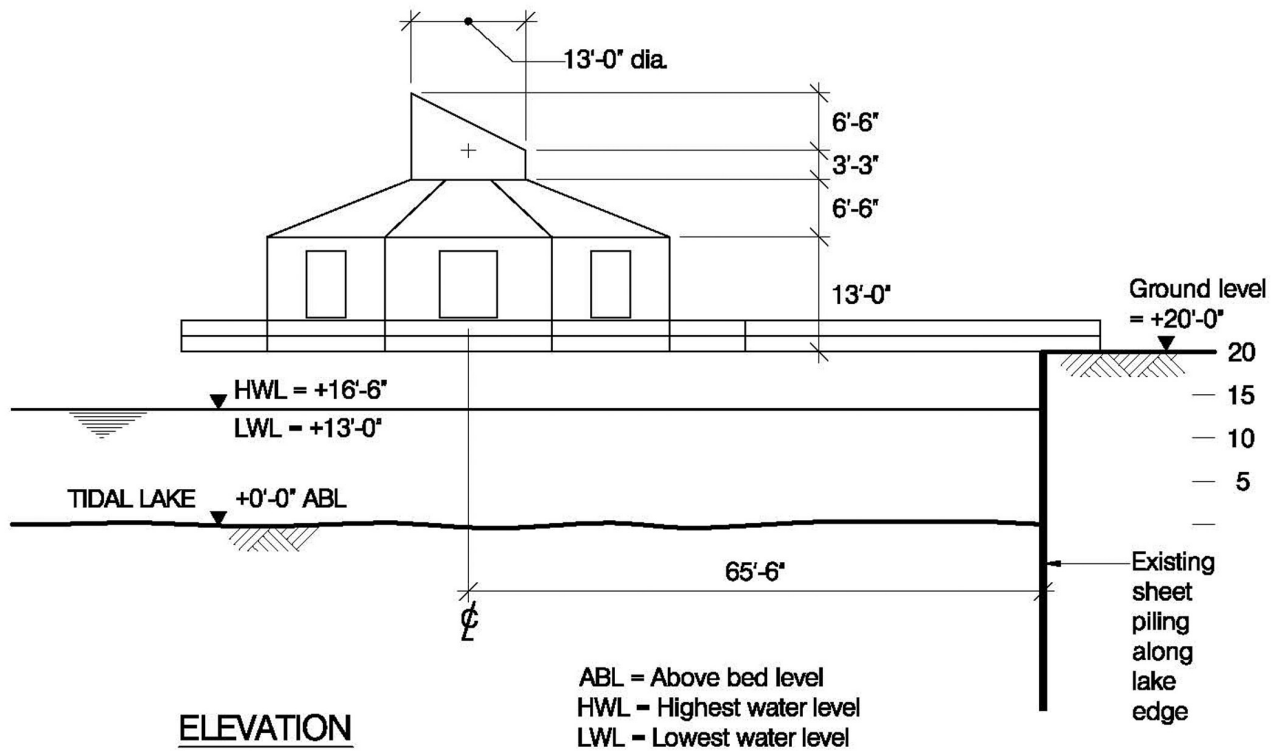
(50 marks)

For the solution recommended in Section 1(a):

- c. Prepare sufficient design calculations to establish the form and size of all the principal structural elements including the foundations. (20 marks)
- d. Prepare general arrangement plans, sections and elevations to show the dimensions, layout and disposition of the structural elements and critical details for estimating purposes. (20 marks)
- e. Prepare a detailed method statement for the safe construction of the structures and an outline construction programme. (10 marks)



**PLAN**



**ELEVATION**

**NOTE:** All dimensions are in feet and inches

**FIGURE Q6**

# Question 6. Waterside Administration Building

## Client's requirements

1. A single storey octagonal administration building is to be built in or over a tidal lake; see Figure Q6. An external terrace is to be provided around the perimeter of the building together with an access walkway. The building and walkway are not to impose any loading onto the existing sheet piled lakeside edge.
2. The building is to have a pitched roof, clad on the underside with timber boarding so that the slope of the timber boarding matches the external slope of the roof. No horizontal ceiling members, ties or internal columns are allowed. A glazed, structure-free circular roof light is to be provided in the centre of the roof.
3. Cladding to the roof and elevations is to be selected to minimise the running and maintenance costs. A 1 hour minimum fire protection is required for all structural members.
4. Windows and doors are shown diagrammatically in Figure Q6. The structural floor level of the administration building is 6" above external structural floor level of the terrace.
5. The access walkway between the edge of the lake and the administration building must not have a gradient greater than 10 horizontal to 1 vertical.
6. Access is not required beneath the administration building or the terrace. There are no restrictions on the type of foundations used provided that they do not extend beyond the edges of the terrace.

## Imposed Loading

- |  |        |
|--|--------|
| 7. Pitched Roof imposed load           | 12psf  |
| Services and ceiling underside of roof | 6psf   |
| Exhibition and Terrace Floor           | 100psf |

## Site Conditions

8. A lake-side site on the edge of a small town. There is a prepared access road serving the site. The lake is tidal with water levels varying between 13'0" to 16'6" above bed level (ABL).
9. Basic wind speed is 90mph based on a 3 second gust; the equivalent mean hourly wind speed is 45mph.
10. Ground conditions:

Bed level - 3'	Soft Clay C=1000psf
3' - 33'	Stiff Clay C =5000psf and $\phi = 0$
Below 33'	Very stiff Clay C =8000psf and $\phi = 0$
Behind sheet piling 20' to bed level	Loose fill – ground water level is equal to lake level

## Omit from consideration

11. Design and stability of the sheet piled lake-side edge

*continued overleaf*



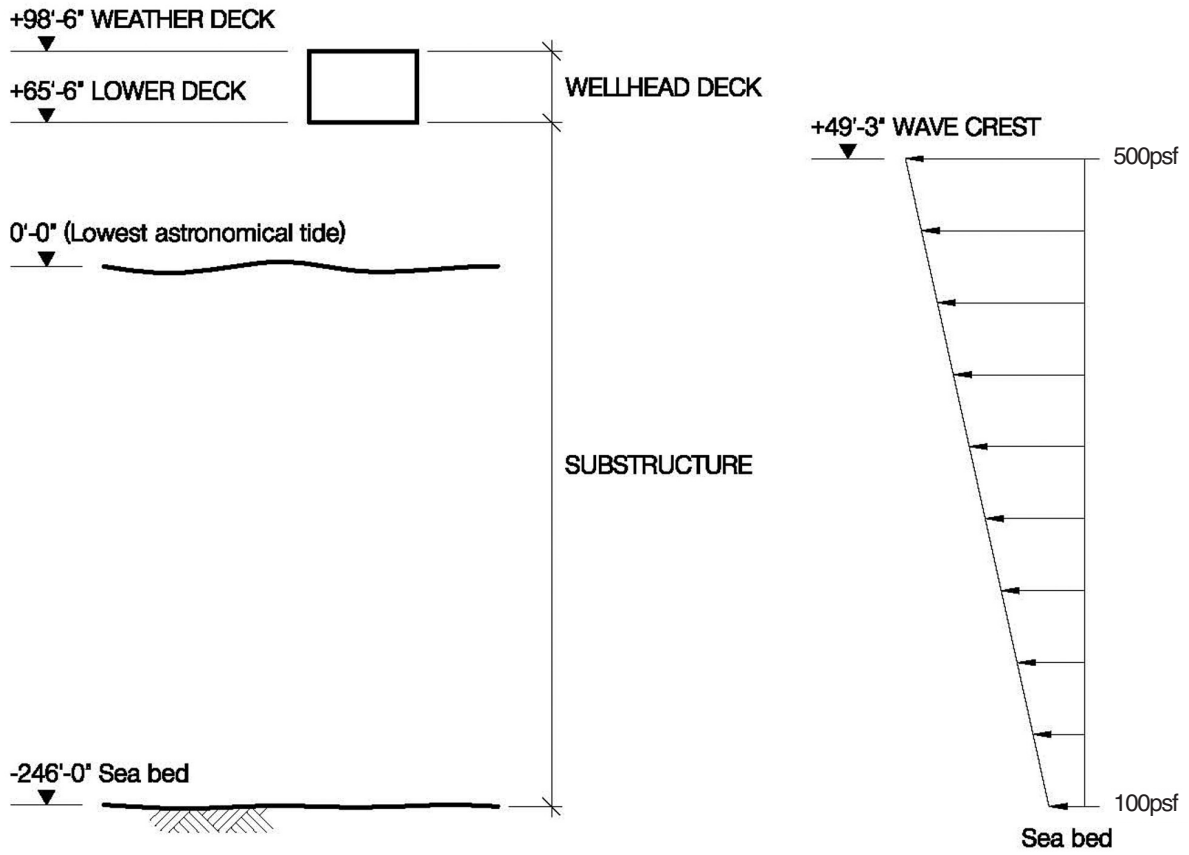
**SECTION 1****(50 marks)**

- a. Prepare a design appraisal with appropriate sketches indicating two distinct and viable solutions for the proposed structure including the foundations. Indicate clearly the functional framing, load transfer and stability aspects of each scheme. Identify the solution you recommend, giving reasons for your choice. (40 marks)
- b. After the design has been completed, the Client needs to reduce the estimated cost of construction but wishes to retain an external pitched roof shape. Write a letter to your client explaining how this might be achieved. (10 marks)

**SECTION 2****(50 marks)**

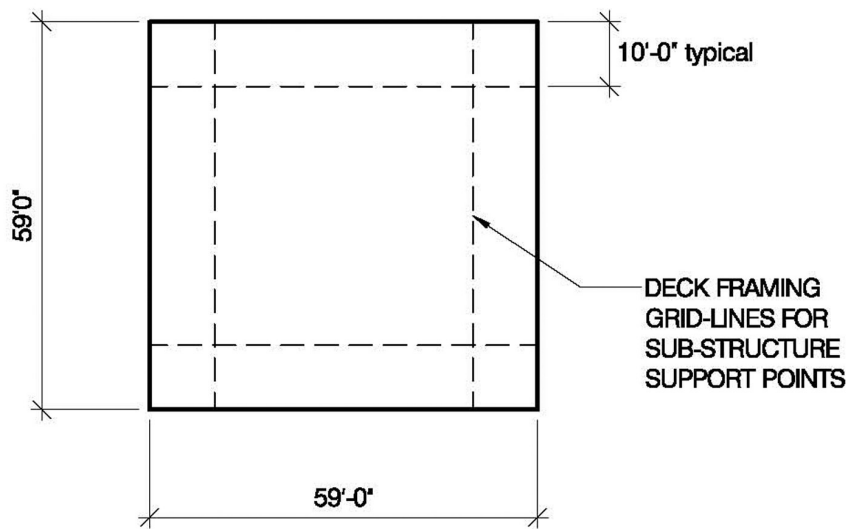
For the solution recommended in Section 1(a):

- c. Prepare sufficient design calculations to establish the form and size of all the principal structural elements including the foundations. (20 marks)
- d. Prepare general arrangement plans, sections and elevations to show the dimensions, layout and disposition of the structural elements and critical details for estimating purposes. (20 marks)
- e. Prepare a detailed method statement for the safe construction of the structure and also the eventual demolition at the end of its useful life. (10 marks)



**ELEVATION**

**WAVE AND CURRENT  
 LOADING ON  
 STRUCTURAL  
 ELEMENTS**



**PLAN ON LOWER DECK  
 (PLAN ON WEATHER DECK SIMILAR)**

**NOTE:** All dimensions are in feet and inches

**FIGURE Q7**

# Question 7. Substructure for a wellhead platform

## Client's requirements

1. A substructure to support a minimum facilities, unmanned, wellhead deck in 246'0" of water; see Figure Q7.
2. The deck is 59'0" long, 59'0" wide and 33'0" high, with the main structure frame grid-lines shown in Figure Q7.
3. The interface points between the substructure and the deck must be on the grid-lines shown in Figure Q7.
4. The substructure must laterally support 4 no. 2'6" diameter conductors at a minimum grid spacing of 8'3".
5. The substructure is to remain intact in the event of accidental supply boat impact, and provide protection to the conductors.

## Imposed Loading

6. The Operating Deck Load is 500tons with the centre of gravity of the load applied at the geometric centre of the deck.
7. Vessel Impact Accidental Damage Impact energy of 1900 BTU to be absorbed by the substructure.

## Site Conditions

8. Extreme wind speed is 102mph based on a 3 second gust; the equivalent mean hourly wind speed is 51mph.
9. Extreme wave and current loading varies linearly from 100psf at the sea-bed to 500psf at the wave crest, see Figure Q7. The load can occur at any horizontal direction.
10. Ground Conditions:

Sea bed level to - 3'	Loose sand
Below - 3'	Hard clay, undrained shear strength, C=6000psf

## Omit from consideration

11. Design of the wellhead deck structure and other appurtenances.
12. Marine growth, dynamic and fatigue structure considerations.
13. Drilling and work-over interface considerations.

## SECTION 1

(50 marks)

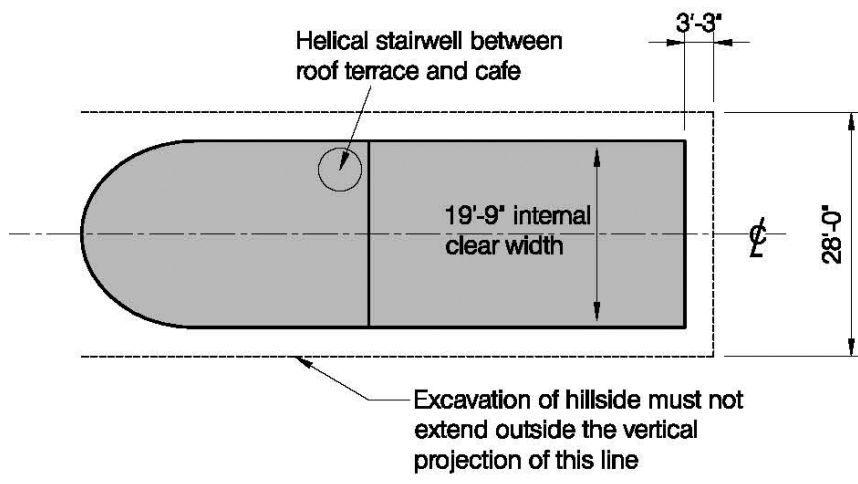
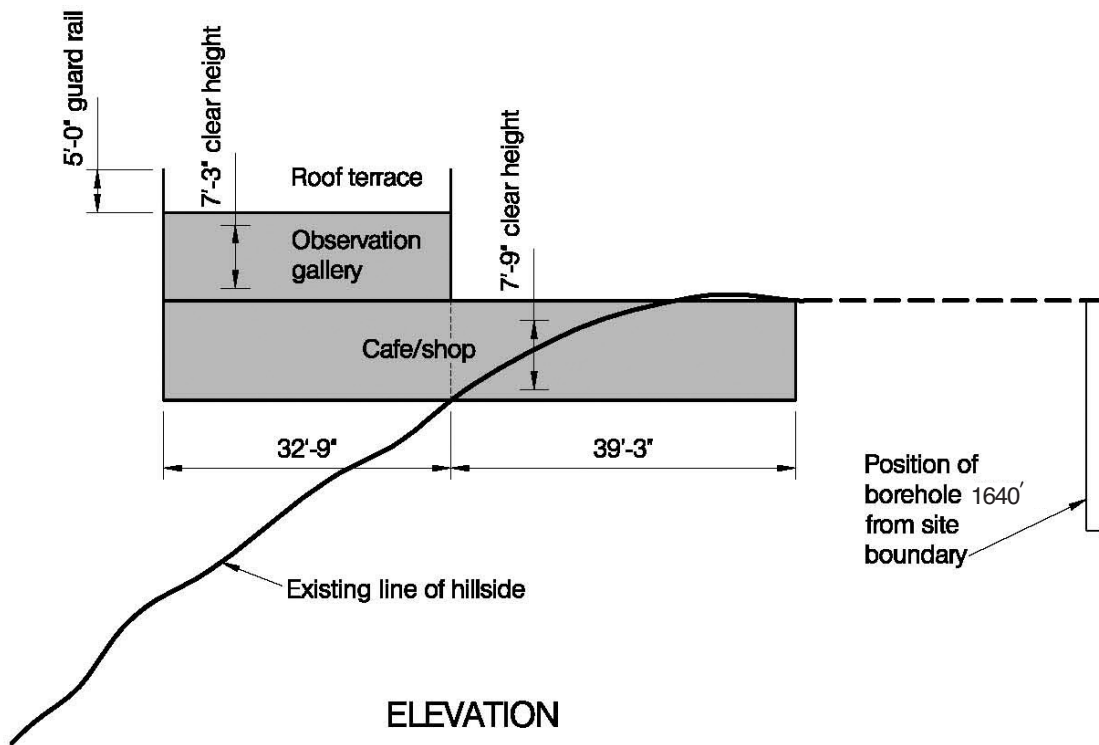
- a. Prepare a design appraisal with appropriate sketches indicating two distinct and viable solutions for the proposed structure including the foundations. Indicate clearly the functional framing, load transfer and stability aspects of each scheme for the temporary and permanent design phases to be considered i.e loadout, transport, installation and in-place operation. Identify the solution you recommend, giving reasons for your choice. (40 marks)
- b. After completion of your design, the Client informs you that the number of conductors is to increase from four to twelve. Write a letter to the client explaining the effects this would have on your chosen solution. (10 marks)

## SECTION 2

(50 marks)

For the solution recommended in Section 1(a):

- c. Prepare sufficient design calculations, for both the temporary and permanent conditions, to establish the form and size of all the principal structural elements and joints, including the foundations. (20 marks)
- d. Prepare general arrangement plans, sections and elevations to show the dimensions, layout and disposition of the structural elements and critical details such as lift points and structure interfaces with the deck and foundations. (20 marks)
- e. With the aid of annotated sketches, prepare a detailed method statement for the safe transport and installation of the substructure at the field location. (10 marks)

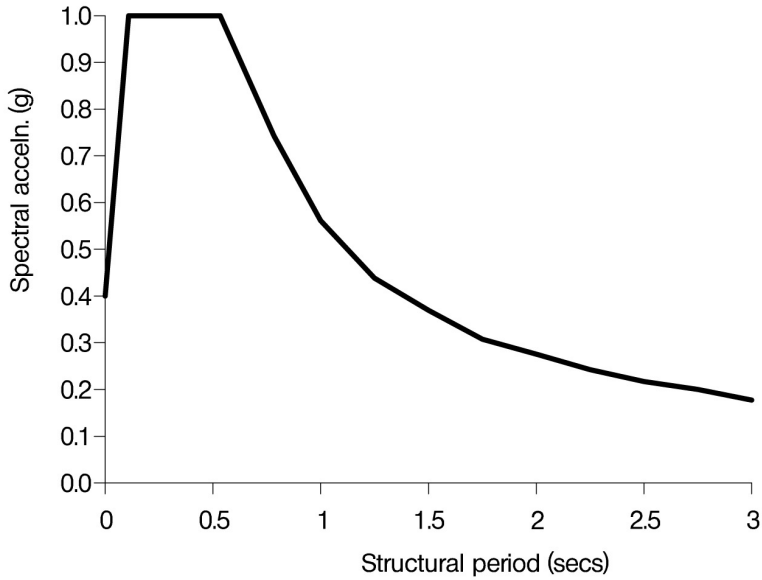


PLAN AND ELEVATION OF OBSERVATION GALLERY

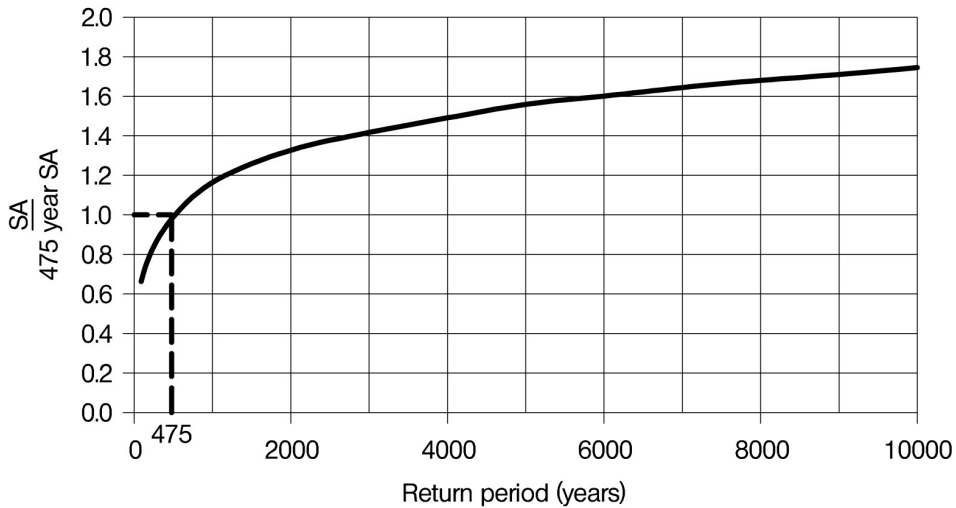
NOTE: All dimensions are in feet and inches

FIGURE Q8-1

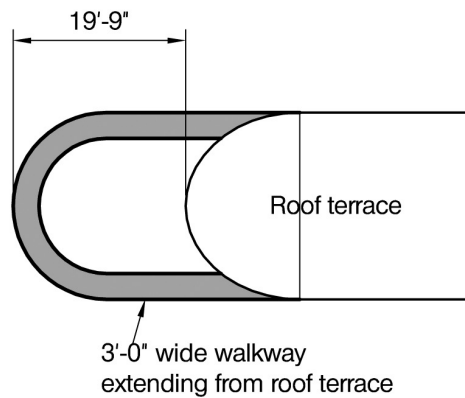




**FIGURE Q8-2 :** 475 year return period 5% damped spectrum for the region for rock with a wave velocity  $V_s$  of at least 2625 ft/s at the surface



**FIGURE Q8-3 :** Variation of spectral acceleration SA with return period



**FIGURE Q8-4 :** Extension to roof terrace (see Section 1b of the question)

NOTE: All dimensions are feet and inches

FIGURE Q8-2



# Question 8. Tourist observation gallery

## Client's requirements

1. A tourist observation gallery and small café/shop is required to be built into a hillside in a remote inland scenic location subject to strong earthquakes; see Figure Q8-1.
2. The visual and environmental impact of the new building on its surroundings must be minimised, both during its construction and in its permanent state.
3. Excavation of the hillside to form the café/shop area must not extend beyond the limits shown on plan in Figure Q8-1.
4. A minimum fire resistance of 1 hour is required for all structural members.
5. An existing 8' 3"-wide unpaved road with gradients up to 8 degrees connects the site to the nearest metalled two-lane road 6 miles away. There are no basic services at the site.

## Imposed Loading

6. Restaurant and shop area	70psf
Observation gallery	100psf
Roof terrace	100psf

## Site Conditions

7. The profile of the existing hillside in elevation is approximately constant across the site.
8. The basic wind speed is 106mph based on a 3-second gust; the equivalent mean hourly wind speed is 53mph.
9. A borehole taken 1640' 0" from the site (see Figure Q8-1) showed the following. Groundwater was not encountered.

Ground level - 1'	Topsoil
1' - 17'	Moderately weak sandstone becoming moderately strong with depth Discontinuity spacing 6" to 10"
Below 17'	Moderately strong to strong sandstone Discontinuity spacing >8"
10. Figure Q8-2 shows the design 5% damped seismic response spectrum for the region. It applies to level ground for a 475 year return period, assuming the ground surface is rock with a shear wave velocity of not less than 2625 ft/s. For seismic designs not using a 475 year return period, Figure Q8-3 may be used to factor the response spectrum of Figure Q8-2, or other appropriate assumptions may be made.

## Omit from consideration

11. Detailed design of cladding; helical stairwell.

## SECTION 1

(50 marks)

- a. Prepare a design appraisal with appropriate sketches indicating two distinct and viable solutions for the proposed structure. Indicate clearly the functional framing, load transfer and stability aspects of each scheme. Identify the solution you recommend, giving reasons for your choice. (40 marks)
- b. During the construction tender period and before work is due to start on site, the client wishes to extend the roof terrace with a 3' 0" wide, horseshoe-shaped walkway, as shown in Figure Q8-4. Write a letter to the client advising on the structural feasibility of this extension and its effect on the project cost and construction programme. (10 marks)

## SECTION 2

(50 marks)

For the solution recommended in Section 1(a):

- c. Prepare sufficient design calculations to establish the form and size of all the principal structural elements including the foundations. (20 marks)
- d. Prepare general arrangement plans, sections and elevations to show the dimensions, layout and disposition of the structural elements and critical details for estimating purposes. (20 marks)
- e. Prepare a detailed method statement for the safe construction of the building and an outline construction programme. (10 marks)

