

Code: AE10  
PART - I

Subject: ELECTRICAL ENGINEERING

## TYPICAL QUESTIONS & ANSWERS

### OBJECTIVE TYPE QUESTIONS

**Q.1** The two windings of a transformer is

- (A) conductively linked.                      (B) inductively linked.  
(C) not linked at all.                          (D) electrically linked.

**Ans : B**

**Q.2** A salient pole synchronous motor is running at no load. Its field current is switched off. The motor will

- (A) come to stop.  
(B) continue to run at synchronous speed.  
(C) continue to run at a speed slightly more than the synchronous speed.  
(D) continue to run at a speed slightly less than the synchronous speed.

**Ans: B**

**Q.3** The d.c. series motor should always be started with load because

- (A) at no load, it will rotate at dangerously high speed.  
(B) it will fail to start.  
(C) it will not develop high starting torque.  
(D) all are true.

**Ans: A**

**Q.4** The frequency of the rotor current in a 3 phase 50 Hz, 4 pole induction motor at full load speed is about

- (A) 50 Hz.    (B) 20 Hz.  
(C) 2 Hz.    (D) Zero.

**Ans: C**

**Q.5** In a stepper motor the angular displacement

- (A) can be precisely controlled.
- (B) it cannot be readily interfaced with micro computer based controller.
- (C) the angular displacement cannot be precisely controlled.
- (D) it cannot be used for positioning of work tables and tools in NC machines.

**Ans: A**

**Q.6** The power factor of a squirrel cage induction motor is

- (A) low at light load only.
- (B) low at heavy load only.
- (C) low at light and heavy load both.
- (D) low at rated load only.

**Ans: A**

**Q.7** The generation voltage is usually

- (A) between 11 KV and 33 KV.
- (B) between 132 KV and 400 KV.
- (C) between 400 KV and 700 KV.
- (D) None of the above.

**Ans: A**

**Q.8** When a synchronous motor is running at synchronous speed, the damper winding produces

- (A) damping torque.
- (B) eddy current torque.
- (C) torque aiding the developed torque.
- (D) no torque.

**Ans: D**

**Q.9** If a transformer primary is energised from a square wave voltage source, its output voltage will be

- (A) A square wave.
- (B) A sine wave.
- (C) A triangular wave.
- (D) A pulse wave.

**Ans: A**

**Q.10** In a d.c. series motor the electromagnetic torque developed is proportional to

- (A)  $I_a$ . (B)  $I_a^2$ .  
(C)  $\frac{1}{I_a}$ . (D)  $\frac{1}{I_a^2}$ .

**Ans: B**

**Q.11** In a 3 – phase induction motor running at slip ‘s’ the mechanical power developed in terms of air gap power  $P_g$  is

- (A)  $(s-1)P_g$ . (B)  $\frac{P_g}{(1-s)}$ .  
(C)  $(1-s)P_g$ . (D)  $s \cdot P_g$ .

**Ans: C**

**Q.12** In a 3 – phase induction motor the maximum torque

- (A) is proportional to rotor resistance  $r_2$ .  
(B) does not depend on  $r_2$ .  
(C) is proportional to  $\sqrt{r_2}$ .  
(D) is proportional to  $r_2^2$ .

**Ans: B**

**Q.13** In a d.c. machine, the armature mmf is

- (A) stationary w.r.t. armature. (B) rotating w.r.t. field.  
(C) stationary w.r.t. field. (D) rotating w.r.t. brushes.

**Ans: C**

**Q.14** In a transformer the voltage regulation will be zero when it operates at

- (A) unity p.f. (B) leading p.f.  
(C) lagging p.f. (D) zero p.f. leading.

**Ans: B**

**Q.15** The maximum power in cylindrical and salient pole machines is obtained respectively at load angles of

- (A)  $90^\circ, 90^\circ$  . (B)  $< 90^\circ, 90^\circ$  .  
(C)  $90^\circ, > 90^\circ$  . (D)  $90^\circ, < 90^\circ$  .

**Ans: D**

**Q.16** The primary winding of a 220/6 V, 50 Hz transformer is energised from 110 V, 60 Hz supply. The secondary output voltage will be

- (A) 3.6 V. (B) 2.5 V.  
(C) 3.0 V. (D) 6.0 V.

**Ans: C**

**Q.17** The emf induced in the primary of a transformer

- (A) is in phase with the flux. (B) lags behind the flux by 90 degree.  
(C) leads the flux by 90 degree. (D) is in phase opposition to that of flux.

**Ans: C**

**Q.18** The relative speed between the magnetic fields of stator and rotor under steady state operation is zero for a

- (A) dc machine. (B) 3 phase induction machine.  
(C) synchronous machine. (D) single phase induction machine.

**Ans: all options are correct**

**Q.19** The current from the stator of an alternator is taken out to the external load circuit through

- (A) slip rings. (B) commutator segments.  
(C) solid connections. (D) carbon brushes.

**Ans: C**

**Q.20** A motor which can conveniently be operated at lagging as well as leading power factors is the

- (A) squirrel cage induction motor. (B) wound rotor induction motor.  
(C) synchronous motor. (D) DC shunt motor.

**Ans: C**

**Q.21** A hysteresis motor

- (A) is not a self-starting motor.                      (B) is a constant speed motor.  
 (C) needs dc excitation.                                (D) can not be run in reverse speed.

**Ans: B**

**Q.22** The most suitable servomotor for low power applications is

- (A) a dc series motor.  
 (B) a dc shunt motor.  
 (C) an ac two-phase induction motor.  
 (D) an ac series motor.

**Ans: B**

**Q.23** The size of a conductor used in power cables depends on the

- (A) operating voltage.                                      (B) power factor.  
 (C) current to be carried.                                (D) type of insulation used.

**Ans: C**

**Q.24** Out of the following methods of heating the one which is independent of supply frequency is

- (A) electric arc heating                                      (B) induction heating  
 (C) electric resistance heating                            (D) dielectric heating

**Ans: C**

**Q.25** A two-winding single phase transformer has a voltage regulation of 4.5% at full-load and unity power-factor. At full-load and 0.80 power-factor lagging load the voltage regulation will be

- (A) 4.5%.    (B) less than 4.5%.  
 (C) more than 4.5%.    (D) 4.5% or more than 4.5%.

**Ans: C**

$$\% R = \frac{V_r \cos \Phi + V_x \sin \Phi}{V_r}$$

$$\text{p.f} = \cos \Phi = 1 \quad \therefore \Phi = 0^\circ$$

$$\therefore \text{kVA} = \text{kW} \ \& \ \text{kVAR} = 0$$

No reactive power component

$$\text{Percentage regulation } (\%R) = V_r \cos \Phi \pm V_x \sin \Phi$$

When  $\cos \Phi = 0.8$  lagging

$$\begin{aligned} \%R &= V_r \cos \Phi + V_x \sin \Phi \\ &= V_r (0.8) + V_x (0.6) \end{aligned}$$

$\%R = (0.8)V_r + (0.6)V_x$  at p.f 0.8 lagging  
and  $\%R = V_r$  at unity p.f

- Q.26** In a dc shunt motor the terminal voltage is halved while the torque is kept constant. The resulting approximate variation in speed ' $\omega$ ' and armature current ' $I_a$ ' will be
- (A) Both  $\omega$  and  $I_a$  are doubled.      (B)  $\omega$  is constant and  $I_a$  is doubled.  
(C)  $\omega$  is doubled while  $I_a$  is halved.      (D)  $\omega$  is constant but  $I_a$  is halved.

**Ans: B**

$$N \propto V - I_a R \quad \text{or } N \propto E_b$$

$$T \propto I_a \Phi, \quad \Phi \propto I_a$$

$$\therefore T \propto I_a^2$$

- Q.27** A balanced three-phase, 50 Hz voltage is applied to a 3 phase, 4 pole, induction motor. When the motor is delivering rated output, the slip is found to be 0.05. The speed of the rotor m.m.f. relative to the rotor structure is
- (A) 1500 r.p.m.      (B) 1425 r.p.m.  
(C) 25 r.p.m.      (D) 75 r.p.m.

**Ans: D**

$$N_s = 120f/P = 120 \times 50/4 = 1500 \text{rpm}$$

$$N = N_s (1-s) = 1500 (1-0.05) = 1425$$

$$\therefore \text{relative speed} = 1500 - 1425 = 75 \text{ rpm}$$

- Q.28** An alternator is delivering rated current at rated voltage and 0.8 power-factor lagging case. If it is required to deliver rated current at rated voltage and 0.8 power-factor leading, the required excitation will be
- (A) less.      (B) more.  
(C) more or less.      (D) the same.

**Ans: B**

Over excitation gives leading power factor and under excitation gives lagging p.f .

**Q.29** A ceiling fan uses

- (A) split-phase motor.
- (B) capacitor start and capacitor run motor.
- (C) universal motor.
- (D) capacitor start motor.

**Ans: D**

To give starting torque and to maintain speed.

**Q.30** A stepper motor is

- (A) a dc motor.
- (B) a single-phase ac motor.
- (C) a multi-phase motor.
- (D) a two phase motor.

**Ans: D**

Stepper motor works on 1-phase-ON or 2-phase –ON modes of operation

**Q.31** The ‘sheath’ is used in cable to

- (A) provide strength to the cable.
- (B) provide proper insulation.
- (C) prevent the moisture from entering the cable.
- (D) avoid chances of rust on strands.

**Ans: A**

The sheath in underground cable is provided to give mechanical strength.

**Q.32** The drive motor used in a mixer-grinder is a

- (A) dc motor.
- (B) induction motor.
- (C) synchronous motor.
- (D) universal motor.

**Ans: D**

The universal motor is suitable for AC & DC both supply systems.

**Q.33** A 1:5 step-up transformer has 120V across the primary and 600 ohms resistance across the secondary. Assuming 100% efficiency, the primary current equals

- (A) 0.2 Amp. (B) 5 Amps.  
(C) 10 Amps. (D) 20 Amps.

**Ans: A**

$$I_1 = V_1 / R_1 = 120/600 = 0.2 \quad (\eta = 100\%, \text{ losses are zero } \therefore V_1 = V_R = I_1 R_1)$$

**Q.34** A dc shunt generator has a speed of 800 rpm when delivering 20 A to the load at the terminal voltage of 220V. If the same machine is run as a motor it takes a line current of 20A from 220V supply. The speed of the machine as a motor will be

- (A) 800 rpm. (B) more than 800 rpm.  
(C) less than 800 rpm. (D) both higher or lower than 800 rpm.

**Ans: C**

$$N_g = E_g (60A / \Phi p z) \quad E_g = V + I_a R_a ; \text{ in generator}$$

$$N_m = E_b (60A / \Phi p z) \quad E_b = V - I_a R_a ; \text{ in motor}$$

$$E_g > E_b \text{ for same terminal voltage}$$

$$\text{Therefore, } N_g > N_m$$

**Q.35** A 50 Hz, 3-phase induction motor has a full load speed of 1440 r.p.m. The number of poles of the motor are

- (A) 4. (B) 6.  
(C) 12. (D) 8.

**Ans: A**

$$N = N_s (1-S) = N_s - N_s \times S$$

$$1440 = N_s (1-S)$$

$$N_s = 1440 / (1-S)$$

$$N_s = (120 f / p) = 120 \times 50 / p = 6000 / p$$

$N_s$  will be closer to N i.e 1440

When P=2 ;  $N_s = 3000$  rpm , not close to N

When P=4 ;  $N_s = 1500$  rpm , it is closer to N

Therefore P =4 for N=1440



**Q. 36** In a 3-phase synchronous motor

- (A) the speed of stator MMF is always more than that of rotor MMF.
- (B) the speed of stator MMF is always less than that of rotor MMF.
- (C) the speed of stator MMF is synchronous speed while that of rotor MMF is zero.
- (D) rotor and stator MMF are stationary with respect to each other.

**Ans: D**

Because, Motor is magnetically locked into position with stator, the rotor poles are engaged with stator poles and both run synchronously in same direction Therefore, rotor & stator mmf are stationary w.r.t each other.

**Q.37** In a capacitor start single-phase induction motor, the capacitor is connected

- (A) in series with main winding.
- (B) in series with auxiliary winding.
- (C) in series with both the windings.
- (D) in parallel with auxiliary winding.

**Ans: B**

To make single phase motor self start. We split the phases at 90 degree. Hence, motor behaves like a two phase motor.

**Q.38** A synchro has

- (A) a 3-phase winding on rotor and a single-phase winding on stator.
- (B) a 3-phase winding on stator and a commutator winding on rotor.
- (C) a 3-phase winding on stator and a single-phase winding on rotor.
- (D) a single-phase winding on stator and a commutator winding on rotor.

**Ans: C**

Synchros : The basic synchro unit called a synchro transmitter. It's construction similar to that of a Three phase alternator.

**Q.39** As the voltage of transmission increases, the volume of conductor

- (A) increases.
- (B) does not change.
- (C) decreases.
- (D) increases proportionately.

**Ans: C**

Decreases due to skin effect.

**Q.40** The size of the feeder is determined primarily by

- (A) the current it is required to carry.
- (B) the percent variation of voltage in the feeder.
- (C) the voltage across the feeder.
- (D) the distance of transmission.

**Ans: A**

Size of conductor depends upon amount of current flow.

**Q. 41** The boundary of the protective zone is determined by the

- (A) Location of CT
- (B) sensitivity of relay used
- (C) Location of PT
- (D) None of these

**Ans: B**

The boundary of the protective zone is determined by the sensitivity of relay used. If the relay is more sensitive, the protective zone will be increased.

**Q.42** In a three phase transformer, if the primary side is connected in star and secondary side is connected in delta, what is the angle difference between phase voltage in the two cases.

- (A) delta side lags by  $-30^\circ$ .
- (B) star side lags by  $-30^\circ$ .
- (C) delta side leads by  $30^\circ$ .
- (D) star side leads by  $-30^\circ$ .

**Ans: C**

This is vector group and has  $+30^\circ$  displacement. Therefore, delta side leads by  $+30^\circ$ .

**Q.43** To achieve low PT error, the burden value should be \_\_\_\_\_.

- (A) low
- (B) high
- (C) medium
- (D) none of the above

**Ans: A**

In a Potential transformer, burden should be in permissible range to maintain errorless measurement.

**Q.44** Slip of the induction machine is 0.02 and the stator supply frequency is 50 Hz. What will be the frequency of the rotor induced emf?

- (A) 10 Hz.
- (B) 50 Hz.
- (C) 1 Hz.
- (D) 2500 Hz.

**Ans: C**

Given :  $s = 0.02$  ;  $f = 50$  Hz

Therefore, frequency of rotor induced emf =  $s f$   
 $= 0.02 \times 50 = 1.0$  Hz

**Q.45** A 4 pole lap wound dc shunt motor rotates at the speed of 1500 rpm, has a flux of 0.4 mWb and the total number of conductors are 1000. What is the value of emf?

(A) 100 Volts.

(B) 0.1 Volts.

(C) 1 Volts.

(D) 10 Volts.

**Ans: D**

Given  $N = 1500$  rpm,  $\Phi = 0.4$  mWb,  $Z = 1000$ ,  $P = 4$ , &  $A = 4$

Therefore,  $E_b = N\Phi PZ / 60 A$   
 $= 1500 \times 0.4 \times 4 \times 1000 \times 10^{-3} / 60 \times 4$   
 $= 60/6 = 10$  volts

**Q.46** The synchronous reactance of the synchronous machine is \_\_\_\_\_.

(A) Ratio between open circuit voltage and short circuit current at constant field current

(B) Ratio between short circuit voltage and open circuit current at constant field current

(C) Ratio between open circuit voltage and short circuit current at different field current

(D) Ratio between short circuit voltage and open circuit current at different field current

**Ans. A**

The Synchronous reactance of a synchronous machine is a total steady state reactance, presented to applied voltage, when rotor is running synchronously without excitation.

Therefore ,  $X_S = E_f / I_S$

= Emf of OC for same  $I_f$  / short circuit current

**Q.47** A 3 stack stepper motor with 12 numbers of rotor teeth has a step angle of \_\_\_\_\_.

(A)  $12^\circ$

(B)  $8^\circ$

(C)  $24^\circ$

(D)  $10^\circ$

**Ans. D**

Given  $m = 3$ ,  $N_r = 12$

Step angle =  $360 / m \times N_r = 360 / 3 \times 12 = 10^\circ$

**Q.48** In case of a universal motor, torque pulsation is minimized by \_\_\_\_\_.

- (A) load inertia (B) rotor inertia  
(C) both rotor and load inertia (D) none of the above

**Ans: C**

In a universal motor, torque pulsation is minimized by rotor and load inertia.

**Q.49** Oil-filled cable has a working stress of \_\_\_\_\_ kV/mm

- (A) 10 (B) 12  
(C) 13 (D) 15

**Ans: D**

This is defined by dielectric strength of mineral oil i.e. 15 kV/mm.

**Q.50** Inverse definite minimum time lag relay is also called \_\_\_\_\_

- (A) pilot relay. (B) differential relay.  
(C) over current relay. (D) directional overcurrent relay.

**Ans: B**

Inverse definite minimum time lag relay characteristic is inverse but minimum time is fixed. The operating time is inversely proportional to the magnitude of actuating quantity.

**Q.51** Specific heat of nickel –chrome is \_\_\_\_\_

- (A) 0.112 (B) 0.106.  
(C) 0.108. (D) 0.110.

**Ans: None of these**

Specific heat of Nickel-Chrome is 440 J/kg°C to 450 J/kg°C

**Q.52** The polarity test is not necessary for the single-phase transformer shown in Fig. 1 so as to correctly determine \_\_\_\_\_ of the transformer.

- (A) shunt branch parameters.  
(B) transformation ratio.  
(C) series parameters.  
(D) any of the above characteristics.

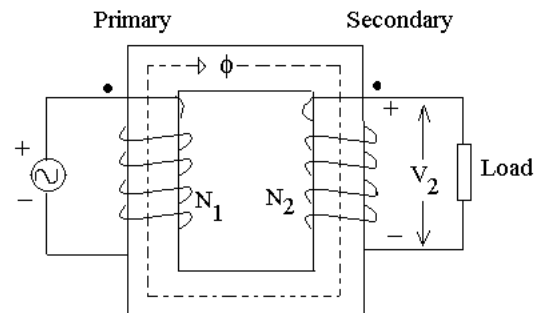

Fig. 1

**Ans: D**

Polarity test is required for parallel operation of transformers to know the direction of current flow in secondary circuit w.r.t primary circuit.

**Q.53** The short-circuit ratio of a typical synchronous machine is obtained from the OCC and SCC curves of Fig.2 as

- (A)  $\frac{oa}{ob}$   
 (B)  $\frac{oa'}{ob'}$   
 (C)  $\frac{oa}{ob'}$   
 (D)  $\frac{oc'}{ob}$

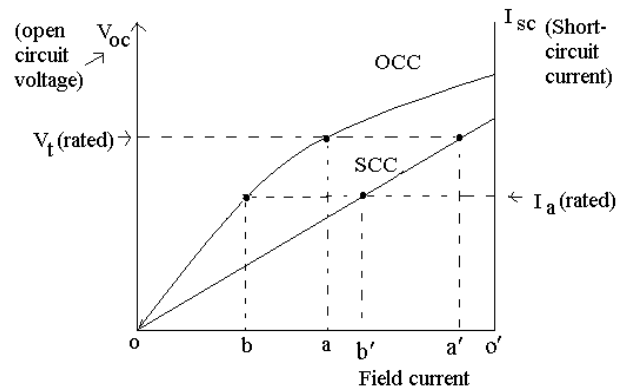

Fig.2

**Ans: B**

As shown in SCC curve the ratio of two field currents

**Q.54** The speed-torque characteristics of a DC series motor are approximately similar to those of the \_\_\_\_\_ motor.

- (A) universal (B) synchronous  
 (C) DC shunt (D) two-phase

**Ans: A**

Universal motor has same characteristics as DC series motor and also known as an a.c series motor.

**Q.55** The rotor frequency for a 3 phase 1000 RPM 6 pole induction motor with a slip of 0.04 is \_\_\_\_\_ Hz

- (A) 8 (B) 4  
 (C) 6 (D) 2

**Ans: D**

Given:  $N=1000$  rpm ;  $P= 6$ ;  $s= 0.04$ ;

and  $f = N \times P / 120$

$$= 1000 \times 6 / 120$$

$$= 50 \text{ Hz}$$

$$\text{Rotor frequency } f_r = s \times f = 0.04 \times 50 = 2.0 \text{ Hz}$$

**Q.56** The torque-speed characteristics of an a.c. operated universal motor has a \_\_\_\_\_ characteristic and it \_\_\_\_\_ be started under no-load condition.

- (A) inverse, can (B) nearly inverse, can  
(C) inverse, cannot (D) nearly inverse, cannot

**Ans: C**

If torque is zero then speed may exceed up to infinite, that is dangerous for machine and machine can be damaged.

$$N \propto 1/T$$

**Q.57** In the heating process of the \_\_\_\_\_ type a simple method of temperature control is possible by means of a special alloy which loses its magnetic properties at a particular high temperature and regains them when cooled to a temperature below this value.

- (A) Indirect induction over (B) core type induction furnace  
(C) coreless induction furnace (D) high frequency eddy current

**Ans: D**

Magnetic property of alloy changes with change of the temperature and

Heat is produced due to eddy current =  $i^2R$  and  $i \propto f^2$

**Q.58** In order to reduce the harmful effects of harmonics on the A.C. side of a high voltage D.C. transmission system \_\_\_\_\_ are provided.

- (A) synchronous condensers (B) shunt capacitors  
(C) shunt filters (D) static compensators

**Ans: C**

$$X_c = 1/\omega c$$

**Q.59** An a.c. tachometer is just a \_\_\_\_\_ with one phase excited from the carrier frequency.

- (A) two-phase A.C. servomotor (B) two-phase induction motor  
(C) A.C. operated universal motor (D) hybrid stepper motor.

**Ans: D**

This is a special purpose machine whose stator coil can be energized by electronically switched current.

**Q.60** The torque, in a \_\_\_\_\_ is proportional to the square of the armature current

- (A) DC shunt motor (B) stepper motor  
(C) 2-phase servomotor (D) DC series motor

**Ans: D**

$$T_a \propto \Phi \cdot I_a \quad \text{and} \quad \Phi \propto I_a \quad ; \quad \text{therefore} \quad T_a \propto I_a^2$$

**Q.61** The synchronous speed for a 3 phase 6-pole induction motor is 1200 rpm. If the number of poles is now reduced to 4 with the frequency remaining constant, the rotor speed with a slip of 5% will be \_\_\_\_\_.

- (A) 1690 rpm (B) 1750 rpm  
(C) 1500 rpm (D) 1710 rpm

**Ans: D**

$$\text{Given : } N_{s1} = 1200, P_1 = 6,$$

$$P_2 = 4, s = 0.05,$$

$$\text{Frequency } f = N_s \times P / 120$$

$$= 120 \times 6 / 120 = 60 \text{ Hz}$$

$$\text{rotor frequency } f' = s \cdot f = 0.05 \times 60 = 3.0 \text{ Hz}$$

$$\text{Now, } N_{s2} = 120 \times 60 / 4 = 1800 \quad \text{and} \quad N_s - N = 120 f' / P_2$$

$$\text{Therefore, } N = N_s - 120 f' / P_2 = 1800 - 120 \times 0.05 \times 60 / 4 = 1800 - 90 = 1710$$

**Q.62** The eddy current loss in an a-c electric motor is 100 watts at 50 Hz. Its loss at 100 Hz will be

- (A) 25 watts (B) 59 watts  
(C) 100 watts (D) 400 watts

**Ans: D**

$$\text{Eddy current losses } \propto f^2$$

$$\text{New loss } \propto (2f)^2$$

$$\text{New loss } \propto 4f^2$$

$$\therefore 4 \text{ times}$$

**Q.63** The maximum power for a given excitation in a synchronous motor is developed when the power angle is equal to

- (A)  $0^\circ$  (B)  $45^\circ$   
(C)  $60^\circ$  (D)  $90^\circ$

**Ans: A**

$$P = VI \cos \Phi$$

$$P_{\max} = VI$$

$$\therefore \Phi = 0^\circ$$

- Q. 64** A commutator in a d.c. machine
- (A) Reduces power loss in armature.
  - (B) Reduces power loss in field circuit.
  - (C) Converts the induced a.c armature voltage into direct voltage.
  - (D) Is not necessary.

**Ans: C**

As name suggests, it commutes ac into dc.

- Q.65** The speed of a d.c. shunt motor at no-load is
- (A) 5 to 10%
  - (B) 15 to 20%
  - (C) 25 to 30%
  - (D) 35 to 40%
- higher than its speed at rated load.

**Ans: A**

$$T_a \propto \Phi I_a, \Phi = \text{constant},$$

$$\therefore T \propto I_a$$

$$N \propto E_b / \Phi \text{ or } N \propto E_b \text{ initially } E_b \text{ less, so speed is less.}$$

- Q.66** The efficiency of a transformer is mainly dependent on
- (A) core losses.
  - (B) copper losses.
  - (C) stray losses.
  - (D) dielectric losses.

**Ans: A**

Core loss has prominent value over other losses

- Q.67** When two transformers are operating in parallel, they will share the load as under:
- (A) proportional to their impedances.
  - (B) inversely proportional to their impedances.
  - (C) 50% - 50%
  - (D) 25%-75%

**Ans: A**

High rating transformer has higher impedance.

kVA rating  $\propto$  Impedance of transformer

- Q.68** If the voltage is reduced to half, the torque developed by an induction motor will be reduced to
- (A)  $\frac{1}{4}$  of original torque.
  - (B)  $\frac{1}{2}$  of original torque.
  - (C)  $\frac{1}{8}$  of original torque.
  - (D)  $\frac{1}{16}$  of original torque.

**Ans: B**

$$T_g \propto V \text{ or } T_g \propto P_m \text{ (rotor gross output)}$$



- Q.69** A 3-phase, 400 volts, 50 Hz, 100 KW, 4 pole squirrel cage induction motor with a rated slip of 2% will have a rotor speed of
- (A) 1500 rpm (B) 1470 rpm  
(C) 1530 rpm (D) 1570 rpm

**Ans: B**

$$N = N_s (1-S) \text{ and } N_s = 120 f / p$$

$$= 120 \times 50 / 4 = 1500 \text{ rpm}$$

$$\therefore N = 1500 (1-0.02) = 1470 \text{ rpm}$$

- Q.70** If the phase angle of the voltage coil of a directional relay is  $50^\circ$ , the maximum torque angle of the relay is
- (A)  $130^\circ$  (B)  $100^\circ$   
(C)  $50^\circ$  (D)  $25^\circ$

**Ans: C**

Torque  $\propto$  Power

Power  $\propto$  Voltage

Therefore, It has same angle as 'V' has.

- Q.71** The voltage at the two ends of a transmission line are 132 KV and its reactance is 40 ohm. The Capacity of the line is
- (A) 435.6 MW (B) 217.8 MW  
(C) 251.5 MW (D) 500 MW

**Ans: A**

Line capacity is determined by power of line

$$P = (V^2/R) \text{ or } (V^2/Z) \text{ when } \cos \Phi = 1$$

- Q.72** A 220/440 V, 50 Hz, 5 KVA, single phase transformer operates on 220V, 40Hz supply with secondary winding open circuited. Then
- (A) Both eddy current and hysteresis losses decreases.  
(B) Both eddy current and hysteresis losses increases.  
(C) Eddy current loss remains the same but hysteresis loss increases.  
(D) Eddy current loss increases but hysteresis loss remains the same.

**Ans: A**

$$W_h = k_h f B_m^{1.6} \text{ and } W_e = k_e f^2 B_m^2 .k$$

Therefore, hysteresis and eddy current losses will be decreased when frequency decreases.

**Q.73** A synchronous motor is operating on no-load at unity power factor. If the field current is increased, power factor will become

- (A) Leading & current will decrease
- (B) Lagging & current will increase.
- (C) Lagging & current will decrease.
- (D) Leading & current will increase.

**Ans: A**

Initially synchronous motor is operating at no load and unity power factor. When field current increases, the excitation will increase. Therefore, p.f will be leading and current will be  $I \cos\Phi < I$

**Q.74** A d.c. shunt motor runs at no load speed of 1140 r.p.m. At full load, armature reaction weakens the main flux by 5% whereas the armature circuit voltage drops by 10%. The motor full load speed in r.p.m. is

- (A) 1080
- (B) 1203
- (C) 1000
- (D) 1200

**Ans: A**

$$N_2 / N_1 = E_{b2} / E_{b1} \times \Phi_1 / \Phi_2 ; \quad \Phi_2 = 0.95\Phi_1 ; \quad E_{b2} = 0.9E_{b1}$$

$$\therefore N_2 / 1140 = 0.9 \times 1 / 0.95$$

$$N_2 = 1080$$

**Q.75** The introduction of interpoles in between the main pole improves the performance of d.c. machines, because

- (A) The interpole produces additional flux to augment the developed torque.
- (B) The flux waveform is improved with reduction in harmonics.
- (C) The inequality of air flux on the top and bottom halves of armature is removed.
- (D) A counter e.m.f. is induced in the coil undergoing commutation.

**Ans: D**

Counter e.m.f. is produced, it neutralizes the reactive emf.

**Q.76** The rotor power output of a 3-phase induction motor is 15 KW and corresponding slip is 4%. The rotor copper loss will be

- (A) 600 W.
- (B) 625 W
- (C) 650 W
- (D) 700 W

**Ans: B**

Rotor copper losses = rotor input - rotor output

and output = (1-s) input

$$\therefore \text{Input} = \text{output} / (1-s) = 15000 / (1-0.04) = 15625$$

$$\therefore \text{loss} = 15625 - 1500 = 625 \text{ watt}$$

**Q.77** The direction of rotation of hysteresis motor is reversed by

- (A) Shift shaded pole with respect to main pole
- (B) Reversing supply lead
- (C) Either A or B
- (D) Neither A nor B

**Ans: A**

This motor used single phase, 50Hz supply and stator has two windings. These are connected continuously from starting to running.

**Q.78** A 1.8° step, 4-phase stepper motor has a total of 40 teeth on 8 pole of stator. The number of rotor teeth for their rotor will be

- (A) 40
- (B) 50
- (C) 100
- (D) 80

**Ans: B**

$$\text{Step angle } \beta = N_s - N_r / N_s N_r \times 360^\circ$$

$$\therefore 1.8 = -40 + N_r / 40 N_r \times 360^\circ$$

$$N_r = 50$$

**Q.79** Low head plants generally use

- (A) Pelton Turbines
- (B) Francis Turbine
- (C) Pelton or Francis Turbine
- (D) Kaplan Turbines

**Ans: A**

In the hysteresis motor, the direction of rotation can be reversed by shifting the shaded pole region with respect to main pole. But not by changing supply lead because it has ac supply.

**Q.80** The charging reactance of 50 Km length of line is 1500Ω. The charging reactance for 100Km length of line will be

- (A) 1500 Ω
- (B) 3000 Ω
- (C) 750 Ω
- (D) 600 Ω

**Ans: B**Characteristic reactance per km =  $1500/50 = 30$  ohms $\therefore$  Characteristic reactance per 100km =  $30 \times 100 = 3000$  ohms**Q.81** Electric ovens using heating elements of \_\_\_\_\_ can produce temperature upto 3000°C.

- (A) Nickel (B) Graphite  
(C) Chromium (D) Iron

**Ans: C**

Chromium has high melting point.

**Q.82** In DC generators, armature reaction is produced actually by

- (A) Its field current. (B) Armature conductors.  
(C) Field pole winding. (D) Load current in armature.

**Ans: D**

Because load current in armature gives rise to armature mmf which react with main field mmf.

**Q.83** Two transformers operating in parallel will share the load depending upon their

- (A) Rating. (B) Leakage reactance.  
(C) Efficiency. (D) Per-unit impedance.

**Ans: A**

Transformers having higher kVA rating will share more load.

**Q.84** As compared to shunt and compound DC motors, the series DC motor will have the highest torque because of its comparatively \_\_\_\_\_ at the start.

- (A) Lower armature resistance. (B) Stronger series field.  
(C) Fewer series turns. (D) Larger armature current.

**Ans: D** $T \propto \Phi I_a$  (before saturation) $\Phi \propto I_a$  $T \propto I_a^2$ **Q.85** A 400kW, 3-phase, 440V, 50Hz induction motor has a speed of 950 r.p.m. on full-load. The machine has 6 poles. The slip of the machine will be \_\_\_\_\_.

- (A) 0.06 (B) 0.10  
(C) 0.04 (D) 0.05

**Ans: D**

$$N = N_s (1-S)$$

$$950 = 120 \times 50 (1-S)/6$$

$$S = 0.05$$

**Q.86** Reduction in the capacitance of a capacitor-start motor, results in reduced

- (A) Noise. (B) Speed.  
(C) Starting torque. (D) Armature reaction.

**Ans: C**

Reduction in the capacitance reduces starting voltage, which results in reduced starting torque.

**Q.87** Regenerative braking

- (A) Can be used for stopping a motor.  
(B) Cannot be easily applied to DC series motors.  
(C) Can be easily applied to DC shunt motors  
(D) Cannot be used when motor load has overhauling characteristics.

**Ans: B**

Because reversal of  $I_a$  would also mean reversal of field and hence of  $E_b$

**Q.88** At present level of technology, which of the following method of generating electric power from sea is most advantageous?

- (A) Tidal power. (B) Ocean thermal energy conversion  
(C) Ocean currents. (D) Wave power.

**Ans: A**

At present level of technology, tidal power for generating electric power from sea is most advantageous because of constant availability of tidal power.

**Q.89** If the field circuits of an unloaded salient pole synchronous motor gets suddenly open circuited, then

- (A) The motor stops.  
(B) It continues to run at the same speed.  
(C) Its runs at the slower speed.  
(D) It runs at a very high speed.

**Ans: B**

The motor continues to run at the same speed because synchronous motor speed does not depend upon load,  $N \propto f$ .

**Q.90** Electric resistance seam welding uses \_\_\_\_\_ electrodes.

- (A) Pointed (B) Disc.  
(C) Flat (D) Domed

**Ans: B**

Disc type electrodes are used for electric resistance seam welding.

**Q.91** For LV applications (below 1 kV), \_\_\_\_\_ cables are used.

- (A) Paper insulated. (B) Plastic.  
(C) Single core cables. (D) Oil filled.

**Ans: C**

For low voltage applications single core cables are suitable.

**Q.92** No load current in a transformer:

- (A) lags the applied voltage by  $90^\circ$   
(B) lags the applied voltage by somewhat less than  $90^\circ$   
(C) leads the applied voltage by  $90^\circ$   
(D) leads the applied voltage by somewhat less than  $90^\circ$

**Ans: B**

The primary input current under no load conditions has to supply (i) iron losses in the core i.e hysteresis loss and eddy current loss (ii) a very small amount of Cu loss in the primary (there being no Cu loss in secondary as it is open)

**Q.93** A transformer operates most efficiently at 3/4th full load. Its iron ( $P_I$ ) and copper loss ( $P_{Cu}$ ) are related as:

- (A)  $P_I/P_{Cu} = 16/9$  (B)  $P_I/P_{Cu} = 4/3$   
(C)  $P_I/P_{Cu} = 3/4$  (D)  $P_I/P_{Cu} = 9/16$

**Ans: D**

If  $P_{Cu}$  is the Cu loss at full load, its value at 75% of full load is

$$P_{Cu} \times (0.75)^2 = 9/16 P_{Cu}$$

At maximum efficiency, it equals the iron loss  $P_I$  which remains constant throughout. Hence max. efficiency at

$$P_1 = 9/16 P_{Cu}$$

$$\text{Or } P_1 / P_{Cu} = 9/16$$

**Q.94** In a salient pole synchronous machine (usual symbols are used):

- (A)  $x_q > x_d$  (B)  $x_q = x_d$   
 (C)  $x_q < x_d$  (D)  $x_q = 0$

**Ans: C**

Since reluctance on the q axis is higher, owing to the larger air gap, hence  $x_q < x_d$

**Q.95** The armature of a dc machine is laminated to reduce:

- (A) Eddy current loss (B) Hysteresis loss  
 (C) copper losses (D) friction and windage losses

**Ans: A**

Thinner the laminations, greater is the resistance offered to the induced e.m.f., smaller the current and hence lesser the  $I^2R$  loss in the core.

**Q.96** The resistance representing mechanical output in the equivalent circuit of an induction motor as seen from the stator is:

- (A)  $r_2' \left( \frac{1}{s} - 1 \right)$  (B)  $\frac{r_2'}{s}$   
 (C)  $r_2'^2 \left( \frac{1}{s} - 1 \right)$  (D)  $\frac{r_2'}{s}$

**Ans: A**

Mechanical Power developed by the rotor ( $P_m$ ) or gross power developed by rotor ( $P_g$ )

= rotor input - rotor Cu losses

$$= (3I^2 R_2' / S) - (3I^2 R_2')$$

$$= 3I^2 R_2' (1/S - 1)$$

**Q.97** A single phase Hysteresis motor

- (A) can run at synchronous speed only  
 (B) can run at sub synchronous speed only  
 (C) can run at synchronous and super synchronous speed  
 (D) can run at synchronous and sub synchronous speed

**Ans: A**

The rotor revolves synchronously because the rotor poles magnetically lock up with the revolving stator poles of opposite polarity

**Q. 98** The temperature of resistance furnaces can be controlled by changing the:

- (A) applied voltage                      (B) number of heating elements  
 (C) circuit configuration                (D) All of the above

**Ans: D**

Temperature of resistance furnaces can be controlled by changing either applied voltage or by number of heating elements or by circuit configuration.

**Q.99** The line trap unit employed in carrier current relaying:

- (A) offers high impedance to 50 Hz power frequency signal  
 (B) offers high impedance to carrier frequency signal  
 (C) offers low impedance to carrier frequency signal  
 (D) Both (A) & (C)

**Ans: B**

The line trap unit employed in carrier current relaying offers high impedance to carrier frequency signal.

Because carrier frequency range is 35 km – 500 kHz

$$X_L = 2\pi f_1$$

Where f increases  $X_L$  will also increases

**Q.100** For a line voltage V and regulation of a transmission line R

- (A)  $R \propto V$                                   (B)  $R \propto 1/V$   
 (C)  $R \propto V^2$                                 (D)  $R \propto 1/V^2$

**Ans: B**

$$R \propto 1/V$$

Regulation =  $(V_0 - V_L) / V_0$ , if  $V_L$  is high the  $(V_0 - V_L)$  will be low.

Therefore  $R \propto 1/V$



Code: AE10  
PART - II

Subject: ELECTRICAL ENGINEERING

## NUMERICALS

- Q.1** Calculate the voltage regulation of a transformer in which ohmic drop is 2% and the reactance drop in 5% of the voltage at 0.8 lagging power factor. (7)

**Ans:** The expression for % voltage regulation is

$$\% \text{ voltage regulation} = \frac{V_{20} - V_{2,fl}}{V_{2,fl}} \times 100 \quad \dots(1)$$

where  $V_{2,fl}$  = rated secondary voltage while supplying full load at a specified power factor.

And  $V_{20}$  = secondary voltage when load is thrown off

Equation (1) can be written as

$$\begin{aligned} \% \text{ Voltage regulation} &= \frac{I(R \cos \phi + X \sin \phi)}{V_2} \times 100 \\ &= \left( \frac{IR}{V_2} \cdot 100 \right) \cos \phi + \left( \frac{IX}{V_2} \cdot 100 \right) \sin \phi \quad \dots(2) \end{aligned}$$

The quantities within the brackets are given in the problem as 2% (percent ohmic drop) and 5% (percent reactance drop). Also  $\phi$  is the lagging power factor angle. The plus sign in Equation (2) is because of the lagging nature of current.

Here  $\cos \phi = 0.8$  and hence  $\sin \phi = \sqrt{1^2 - (0.8)^2} = 0.6$

Now

$$\begin{aligned} \text{Voltage regulation} &= 2\% \times 0.8 + 5\% \times 0.6 \\ &= (1.6 + 3.0)\% \\ &= 4.6\% \end{aligned}$$

Hence voltage regulation = 4.6%

Q.2 Derive the expression of torque produced in a d.c. motor. (7)

Ans:

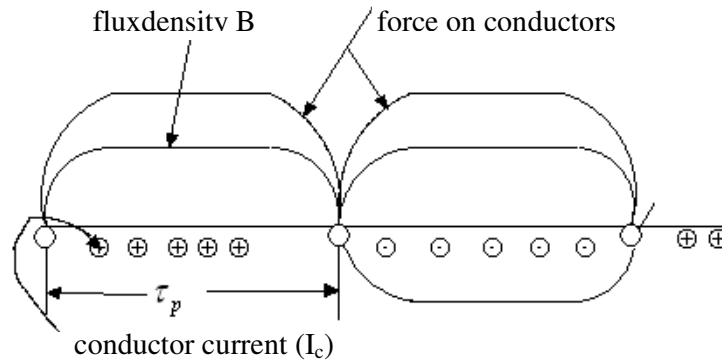

Fig. C1 Torque production in dc machine

Fig. C1 shows the flux density wave in the air gap and the conductor current distribution in the developed armature for one pole-pair. The force on the conductors is unidirectional. Each conductor, as it moves around with the armature, experiences a force whose time variation is a replica of the flux density(B).

Therefore, the average conductor force

$$f_{c(av)} = B_{av} l I_c \quad (1)$$

where  $B_{av}$  = average flux density over a pole.

$l$  = active conductor length, and  $I_c$  = conductor current

Total force

$$F = z f_{c(av)} = B_{av} I_c l z, \text{ where } z = \text{total number of conductors} \quad (2)$$

This force (and therefore torque) is constant because both the flux density wave and current distribution are fixed in space at all times. Now the torque developed is

$$T = B_{av} I_c l z r \quad (3)$$

where  $r$  is the mean air gap radius

The flux/pole can be expressed as

$$\phi = B_{av} \tau_p l \quad (4)$$

where  $\tau_p = \text{polepitch} = \frac{2\pi r}{P}$

so

$$\phi = B_{av} \left( \frac{2\pi r}{P} \right) l$$

or

$$B_{av} = \frac{\phi P}{2\pi} \times \frac{1}{rl} \quad (5)$$

Substituting for  $B_{av}$  in (3)

$$T = \frac{\phi P}{2\pi} \times \frac{1}{rl} I_c l z r$$

or

$$T = \frac{\phi P I_c z}{2\pi} = \frac{(\phi P) \times I_c z}{2\pi}$$

A lap winding is assumed here. It has  $A=p$  parallel paths such that the armature current  $I_a$  divides out into 'A' paths giving a conductor current of

$$I_c = \frac{I_a}{A}$$

Thus

$$T = \frac{\phi I_a z}{2\pi} \times \left( \frac{P}{A} \right) \text{ Nm}$$

$$\Rightarrow T = K_a \phi I_a \quad \text{where } K_a = \frac{zP}{2\pi A} = \text{constant} \quad (6)$$

- Q.3** A 230 V d.c. shunt motor with constant field drives a load whose torque is proportional to the speed. When running at 750 rpm it takes 30 A. Find the speed at which it will run if a 10 ohm resistance is connected in series with the armature. The armature resistance may be neglected. (7)

**Ans:** Fig. C2 shows a dc shunt motor

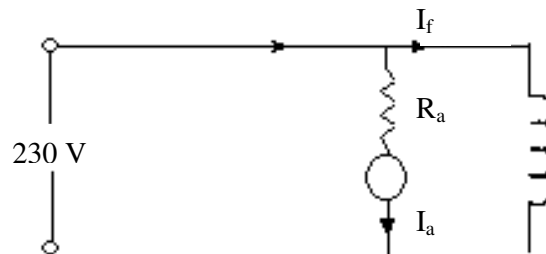

Fig. C2

Using equation 6 of Question 2, the torque

$$T = K_a \phi I_a$$

Original variables are  $T_1, \phi_1, N_1, I_{a1}$  and  $E_{a1}$

Final variables are  $T_2, \phi_2, N_2, I_{a2}$  and  $E_{a2}$

$$\text{Now } \frac{T_1}{T_2} = \frac{K_a \phi_1 I_{a1}}{K_a \phi_2 I_{a2}} = \frac{I_{a1}}{I_{a2}} \quad (1)$$

Here  $\phi_1 = \phi_2$  as flux is constant

Since torque is proportional to speed

$$\frac{T_1}{T_2} = \frac{N_1}{N_2} = \frac{I_{a1}}{I_{a2}} \text{ from equation (1)} \quad (2)$$

$$\text{And } I_{a2} = I_{a1} \frac{N_2}{N_1} \quad (3)$$

$$\text{Back emf } \frac{E_{a1}}{E_{a2}} = \frac{V_T - 0}{V_T - I_{a2} R} = \frac{K_a \phi N_1}{K_a \phi N_2}$$

$$\text{Or } \frac{230 - I_{a2} \times 10}{230} = \frac{N_2}{N_1}$$

$$\text{Or } \frac{230 - 10 \times I_{a1} \times \left(\frac{N_2}{N_1}\right)}{230} = \frac{N_2}{N_1}$$

$$\text{Or } \frac{230 - 10 \times 30 \times \left(\frac{N_2}{N_1}\right)}{230} = \frac{N_2}{N_1}$$

This gives

$$\frac{N_2}{N_1} (230 + 300) = 230$$

Therefore

$$N_2 = N_1 \frac{230}{530}$$

$$= 750 \times \frac{230}{530}$$

$$= 326 \text{rpm}$$

**Q.4** The power input to a 500 V, 50 Hz, 6 pole 3 phase squirrel cage induction motor running at 975 rpm is 40 KW. The stator losses are 1 KW and the friction and windage losses are 2 KW. Calculate

- (i) Slip (ii) Rotor copper loss  
 (iii) Mechanical power developed (iv) The efficiency. (7)

**Ans:** Synchronous speed( $N_s$ ) =  $\frac{120f}{P} = 120 \times \frac{50}{6} = 1000 \text{RPM}$

$$\text{Slip} = \frac{\omega_s - \omega_m}{\omega_s} = \frac{2\pi \times 1000 - 2\pi \times 975}{2\pi \times 1000} = \frac{25}{1000} = 0.025$$

Power across air gap( $P_G$ ) = power input - stator copper loss

Thus  $P_G = 40 \text{KW} - 1 \text{KW} = 39 \text{KW}$

Rotor copper loss =  $sP_G = 0.025 \times 39 = 0.975 \text{KW}$

Gross mechanical output =  $(1-s)P_G = 39 - 0.975 = 38.025 \text{KW}$

Net mechanical output = Gross mechanical output - friction and winding loss

$$= (38.025 - 2.000) \text{KW}$$

$$= 36.025 \text{KW}$$

$$\text{Efficiency} = \frac{\text{Net Mech output}}{\text{Power input}} = \frac{36.025}{40}$$

$$\approx 90\%$$

Note: Assume that the core loss is included in friction and windage loss and the total loss under this head is 2.0 kW

- Q.5** A 120V, 60Hz, 1/4hp universal motor runs at 2000 rpm and takes 0.6A when connected to a 120V d.c. source. Determine the speed, torque and power factor of the motor when it is connected to a 120V, 60 Hz, supply and is loaded to take 0.6A (rms) of current. The resistance and inductance measured at the terminals of the motor are 20 ohm and 0.25H respectively. (7)

**Ans: Universal Motor:** (A) When connected to a d.c. source it runs at 2000RPM and takes 0.6A [Fig F1]

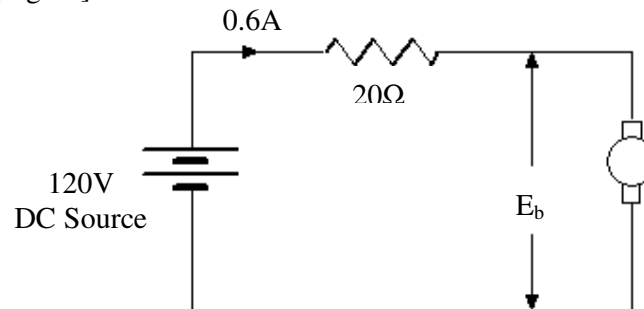

Fig F1

$$E_b = 120 - 0.6 \times 20 = 120 - 12 = 108V$$

$$E_{b(d.c.)} = \frac{\phi n_1 Z}{60} \times \frac{P}{A} = Kn_{dc} = 108V$$

**When connected an ac source [120 Volts, 60Hz supply]**

it takes 0.6A of current

$$E_{a(ac)RMS} = \frac{1}{\sqrt{2}} \frac{\phi n_2 Z}{60} * \frac{P}{A} = \frac{Kn_{ac}}{\sqrt{2}}$$

$$R_{motor} = 20 \Omega$$

$$L_{motor} = 0.25H$$

$$X_{motor} = 2 \pi \times 60 \times 0.25$$

$$\text{Or, } X_{motor} = 94.25 \Omega$$

From the phasor diagram

$$E_{a(ac)} + I_a R = \sqrt{V^2 - (I_a X)^2}$$

$$E_{a(ac)} = -0.6 \times 20 + \sqrt{120^2 - (0.6 \times 94.25)^2}$$

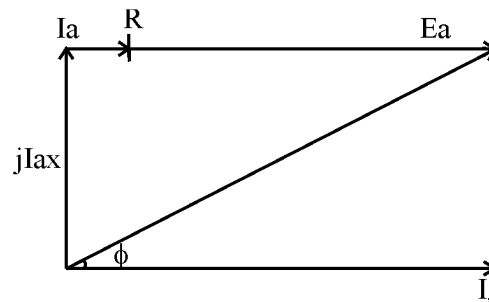

Fig F2

$$= -12 + 105.84 = 93.84 \text{ V}$$

Assume, same flux for the same current (i.e.  $0.6 A_{dc}$  and  $0.6 A_{rms}$ )

$$\frac{E_{a(dc)}}{E_{a(ac)}} = \frac{\phi n_{dc}}{\phi n_{ac}} = \frac{n_{dc}}{n_{ac}}$$

Therefore

$$n_{ac} = 2000 \times \frac{93.84}{108} = 1737.78 \text{ rpm}$$

$$\text{Power factor, } \cos \phi = \frac{E_{a(ac)} + I_a R}{V} = \frac{93.84 + 12}{120} = 0.88 \text{ lag}$$

$$P_{mech} = E_{a(ac)} I_a = 93.84 \times 0.6 = 56.3 \text{ W}$$

$$T_{dev} = \frac{P_{mech}}{\omega_m} = \frac{56.3}{2\pi \times \frac{1737.78}{60}} = 0.309 \text{ N-m}$$

- Q.6** For a 4 KVA, 200/400 V, 50 Hz, 1 – phase transformer, calculate the efficiency, voltage at the secondary terminals and primary input current when supplying a full – load secondary current at 0.8 lagging power factor.

The following are the test results:

Open circuit with 200 V applied to the L.V. side: 0.8 A, 70 W. Short circuit with 20 V applied to the H.V. side: 10 A, 60 W. (14)

**Ans:** The transformer is supplying full-load secondary current at 0.8 lagging power factor

$$\text{Full load secondary current} = \frac{4 \text{ KVA}}{400 \text{ V}} = \frac{4000 \text{ VA}}{400 \text{ V}} = 10 \text{ A}$$

From the open circuit test, core losses = 70 W

From the S.C. test, full load copper losses = 60 W

(a) Efficiency

$$\eta = \left( \frac{V_2 I_2 \cos \theta}{V_2 I_2 \cos \theta + \text{core losses} + \text{full load copper losses}} \right) \times 100$$

$$= \left( \frac{4000 \times 0.8}{4000 \times 0.8 + 70 + 60} \right) \times 100$$

$$= \left( \frac{3200}{3300} \right) \times 100 = 96.1\%$$

(b) voltage at the secondary terminals is determined as follows with the help of equivalent circuit of Fig A3

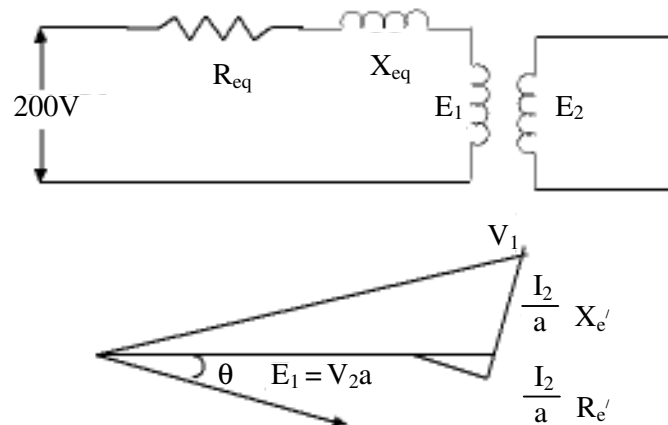

**Fig. A3** Equivalent circuit referred to primary

Primary eqt. resistance =  $r_1 + a^2 r_2 = a^2$  [eqt. resistance referred to secy]

Also primary eqt. reactance =  $x_1 + a^2 x_2 = a^2$  [eqt. reactance referred to secy]

Where  $a = \frac{200}{400} = \frac{1}{2}$

From the short circuit test conducted on the secondary side.

$$Z = \frac{20}{10} = 2\Omega$$

$$R = \frac{60W}{10^2} = 0.6\Omega$$

$$X = \sqrt{2^2 - (0.6)^2} = \sqrt{3.64} = 1.91\Omega$$

$$\text{Eqt. Resistance referred to primary } R'_e = a^2 R = \frac{0.6}{4} = 0.15 \Omega$$

$$\text{Eqt. reactance referred to primary } X'_e = a^2 X = \frac{1.91}{4} \approx 0.48\Omega$$



$$(E_1 + IR'_e \cos \phi + IX'_e \sin \phi)^2 + (IX'_e \cos \phi - IR'_e \sin \phi)^2 = 200^2$$

$$(E_1 + 20 \times 0.15 \times 0.8 + 20 \times 0.48 \times 0.6)^2 + (20 \times 0.48 \times 0.8 - 20 \times 0.15 \times 0.6)^2 = 200^2$$

$$\Rightarrow (E_1 + 8.16)^2 + (5.88)^2 = 200^2$$

This gives  $E_1 \approx 191.75$

$$E_2 = 191.75 \times 2 = 383.5$$

So voltage at secondary terminals = 383.5V

Primary input current with full load secondary current = 20A

- Q.7** Draw the per phase approximate equivalent circuit of a 3 – phase induction motor at slip 's' and derive the expression for electromagnetic torque developed by the motor. Derive also the condition for maximum torque and the expression for the maximum torque. **(14)**

**Ans:**

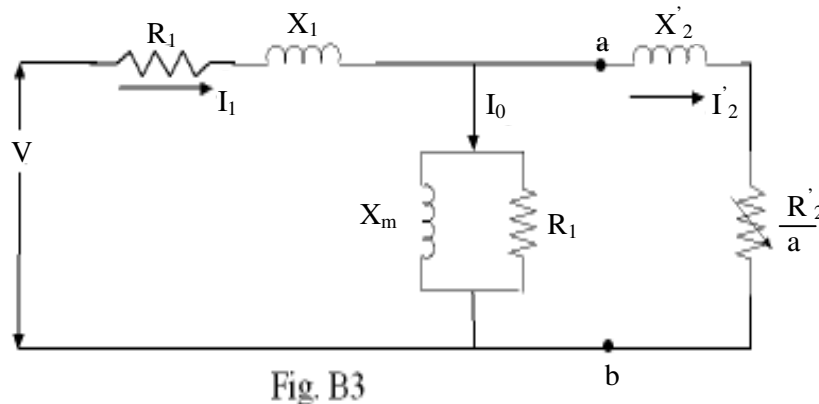

Fig. B3

Fig B3 shows the per-phase exact equivalent circuit of a 3-phase induction motor. The power crossing the terminals 'ab' in Fig B3 is the electrical power input per phase minus the stator copper loss and iron loss; Thus it is the power that is transferred from the stator to the rotor via the air gap. It is also known as the power across the air gap.

$$\text{The Power across the air gap } (P_a) = \frac{3(I'_2)^2 R'_2}{s}$$

Rotor speed is  $\omega = (1 - s)\omega_s$  mech.rad./s

Electromagnetic torque developed is obtained as

$$(1 - s) \omega_s T = P_m = (1 - s) P_G$$

$$\text{or } T = \frac{P_G}{\omega_s} = \frac{3(I_2')^2 R_2'}{s\omega_s}$$

The condition (that is, slip) for maximum torque is obtained by equating  $\frac{dT}{ds}$  to zero.

With the approximation of  $I_1 = I_2'$  in Fig. B3 or using the approximate equivalent circuit.

$$I_2' = \frac{V}{\left[ (R_1 + R_2'/s)^2 + (X_1 + X_2')^2 \right]^{1/2}}$$

$$T = \frac{3(I_2')^2 R_2'}{s\omega_s} = \frac{3R_2' V^2}{s\omega_s \left[ (R_1 + R_2'/s)^2 + (X_1 + X_2')^2 \right]^{1/2}} \quad \text{---(I)}$$

Equating  $\frac{dT}{ds}$  to zero gives the slip at maximum torque as

$$s_m = \pm \frac{R_2'}{\left[ R_1^2 + (X_1 + X_2')^2 \right]^{1/2}}$$

Also substitution of  $s_m$  for  $s$  in (I) gives the maximum torque as

$$T_{\max} = \frac{3}{2\omega_s} \frac{V^2}{\left[ R_1 + \sqrt{R_1^2 + (X_1 + X_2')^2} \right]}$$

**Q.8** A 230 V d.c. series motor has an armature resistance of 0.2  $\Omega$  and series field resistance of 0.10  $\Omega$ . Determine:

- (i) the current required to develop a torque of 70 Nm at 1200 rpm
- (ii) percentage reduction in flux when the machine runs at 2000 rpm at half the current. (14)

**Ans:**

**DC Series Motor:**

$$\text{Back emf } E_a = \frac{\phi ZP}{60} \cdot \frac{n}{A} = \phi n \frac{ZP}{60A}$$

$$\text{Define } K_n = \frac{60A}{ZP}$$

$$\text{So } E_a = \frac{\phi n}{K_n} \text{----- (A)}$$

$$\text{Also } T = \frac{1}{2\pi} \phi I_a Z \frac{P}{A} = \phi I_a \cdot \frac{ZP}{2\pi A}$$

$$\frac{ZP}{2\pi A} = \frac{ZP}{60A} \cdot \frac{60}{2\pi} = \frac{1}{K_n} \cdot \frac{60}{2\pi}$$

$$\text{So } T = \frac{\phi I_a}{K_n} \times \frac{60}{2\pi}$$

Also for a series motor

$$E_a = V - I_a (R_a + R_{se}) \text{----- (B)}$$

where V is the applied voltage and  $I_a$  is the current through armature and series field.

Here  $R_a = 0.2 \Omega$  and  $R_{se} = 0.1 \Omega$

From (A) and (B)

$$\frac{n\phi}{K_n} = 230 - I_a (0.2 + 0.1)$$

$$\frac{1200\phi}{K_n} = 230 - 0.3I_a \text{----- (C)}$$

$$\text{also } 70 = \frac{60}{2\pi} \frac{\phi}{K_n} I_a$$

or

$$\frac{\phi}{K_n} = \frac{70}{60} \times \frac{2\pi}{I_a} \text{----- (D)}$$

From (C) and (D)

$$\frac{1200 \times 70 \times 2\pi}{60I_a} = 230 - 0.3I_a$$

$$\text{or } \frac{8796}{I_a} = 230 - 0.3I_a$$

$$\Rightarrow 0.3I_a^2 - 230I_a + 8796 = 0$$

This gives  $I_a = 40.33A$  or  $726.33A$

The second value (726.33A) is inadmissible.

- (i) Hence the current required to develop a torque of 70Nm at 1200RPM is 40.33A
- (ii) Machine runs at 2000RPM

$$\frac{n_2 \phi_2}{K_n} = 230 - 0.3 \times 20.17$$

$$2000 \frac{\phi_2}{K_n} = 230 - 6.05$$

$$2000 \frac{\phi_2}{K_n} = 224 \text{ ————— (E)}$$

From (C)  $\frac{1200\phi}{K_n} = 230 - 0.3(40.33) = 217.9 \text{ ————— (F)}$

Division of (F) by (E) gives

$$\frac{1200\phi}{2000\phi_2} = \frac{217.9}{224}$$

or

$$\frac{\phi_2}{\phi} = \frac{1200 \times 224}{2000 \times 217.9} = 0.617$$

$$\text{This gives } \phi_2 = 0.617\phi$$

or reduction in flux in the second case is 38.3% of the original flux.

- Q.9** The effective resistance of a 3 – phase, Y – connected 50 Hz, 2200 V synchronous generator is 0.5  $\Omega$  per phase. On short circuit a field current of 40 A gives the full load current of 200 A. An emf (line to line) of 1100 V is produced on open circuit with the same field current. Determine the synchronous impedance. Also compute the power angle and voltage regulation at full – load 0.8 lagging p.f. **(14)**

**Ans:** The occ and scc characteristics of the synchronous generator are given in Fig. M4

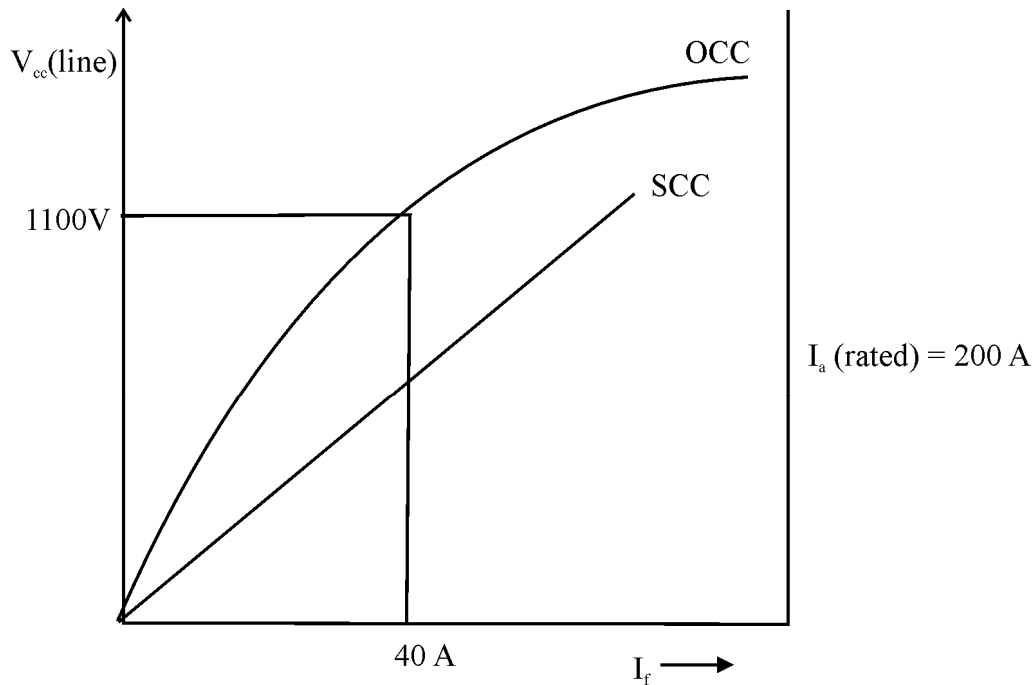

Fig. M4 Occ and Scc characteristics

Synchronous impedance  $Z_s = \frac{\text{open circuit voltage for } I_f \text{ of } 40A}{\text{short circuit current for the same } I_f \text{ of } 40A}$

$$\text{Thus } X_s \approx Z_s = \frac{1100}{\sqrt{3} \times 200} = 3.18 \Omega$$

Percentage voltage regulation is defined as  $\frac{E_f - V_{t(\text{rated})}}{V_{t(\text{rated})}} \times 100\%$

The phasor diagram is given in Fig. M5

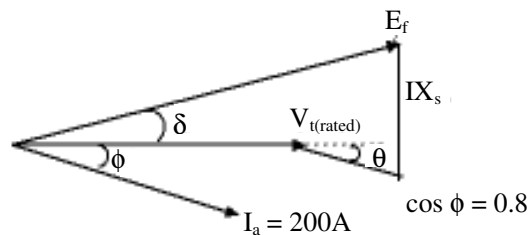

Fig. M5 Phasor diagram

$$\text{Here } V_{t(\text{rated})} = \frac{2200}{\sqrt{3}}$$

$$\cos \phi = 0.8$$

$$E_f^2 = (V_t + I r_a \cos \phi + I X_s \sin \phi)^2 + (I X_s \cos \phi - I r_a \sin \phi)^2$$

where  $V_t$ (terminal voltage) and  $E_f$ (field voltage) are per phase values

$$\Rightarrow E_f = \left[ \left( \frac{2200}{\sqrt{3}} + 200 \times 0.5 \times 0.8 + 200 \times 3.18 \times 0.6 \right)^2 + \left( 200 \times 3.18 \times 0.8 - 200 \times 0.5 \times 0.6 \right)^2 \right]^{1/2}$$

$$E_f = \sqrt{1731.6^2 + 448.8^2} = 1788.8$$

$$\text{Percent regulation} = \frac{E_f - V_{t(\text{rated})}}{V_{t(\text{rated})}} \times 100$$

$$\Rightarrow \% \text{reg}^n = \frac{1788.8 - 1270}{1270} \times 100 = 48.85\%$$

$$\tan \delta = \frac{448.8}{1731.6} = 0.259$$

$$\delta = 14.5^\circ$$

Thus power angle =  $14.5^\circ$

- Q.10** A 100 KVA, 2400/240 V, 50 Hz, 1-phase transformer has no-load current of 0.64 A and a core loss of 700 W, when its high voltage side is energized at rated voltage and frequency. Calculate the two components of no-load current. If this transformer supplies a load current of 40 amp at 0.8 lagging power factor at its low voltage side, determine the primary current and its power factor. Ignore leakage impedance drop. (12)

**Ans:**

100 KVA, 2400/240 V, 50Hz, 1- $\Phi$

**No load: -**

$$I_o = 0.64 \text{ A}$$

$$W_o = 700 \text{ W}$$

$$\text{Iron loss current} = 700/2400 = 0.2916 \text{ A}$$

$$\text{Now, } I_o^2 = I_w^2 + I_\mu^2$$

$$\begin{aligned} \text{Magnetizing component } I_\mu &= (I_o^2 - I_w^2)^{1/2} \\ &= (0.64^2 - 0.2916^2)^{1/2} \\ &= 0.5697 \text{ A} \end{aligned}$$

**On load :-**

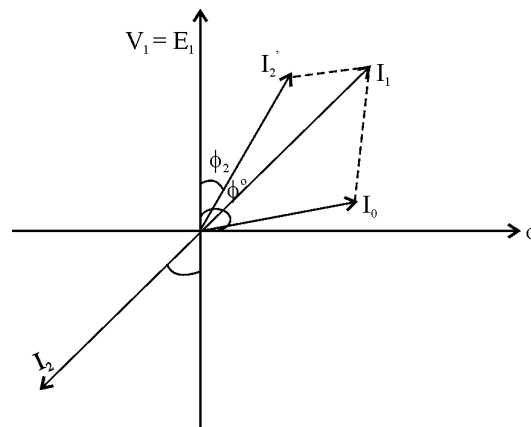

$$I_2 = 40 \text{ A}$$

$$\Phi_2 = 0.8 \text{ lag}$$

$$\begin{aligned} \cos \Phi_o &= W_o / (V_o I_o) \\ &= 700 / (2400 \times 0.64) \\ &= 0.455 \end{aligned}$$

$$\begin{aligned} \Phi_o &= \cos^{-1} 0.455 \\ &= 62.88^\circ \end{aligned}$$

$$\begin{aligned} \Phi_2 &= \cos^{-1} 0.8 \\ &= 36.86^\circ \end{aligned}$$

$$\text{Now, turn ratio } K = V_1 / V_2 = 240 / 2400 = 0.1$$

$$I_2^1 = KI_2 = 40 \times 0.1 = 4 \text{ A}$$

$$\begin{aligned} \text{Angle between } I_0 \text{ and } I_2^1 &= 62.88^\circ - 36.86^\circ \\ &= 26.02^\circ \end{aligned}$$

$$I_0 = 0.64 \angle -62.88^\circ$$

$$I_2^1 = 4 \angle -36.86^\circ$$

$$\begin{aligned} I_1 = I_0 + I_2^1 &= 0.64 [\cos(62.88) - j \sin(62.88)] + 4 [\cos(36.86) - j \sin(36.86)] \\ &= 4.583 \end{aligned}$$

$$I_1 = 4.583 \text{ A}$$

$$\cos \Phi_1 = \cos 40.37 = 0.7618 \text{ lag}$$

- Q.11** A shunt generator has an induced emf of 254 V. When the generator is loaded, the terminal voltage is 240 V. Neglecting armature reaction, find the load current if the armature resistance is 0.04 ohm and the field circuit resistance is 24 ohms. (10)

**Ans:**

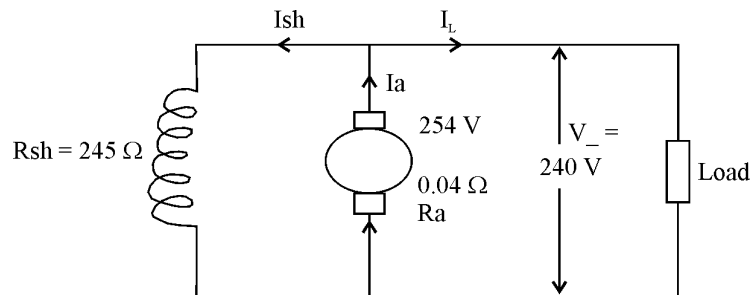

$$E_g = 254 \text{ V}$$

$$V = 240 \text{ V}$$

$$R_a = 0.04 \Omega, R_{sh} = 24 \Omega$$

$$E_g = V + I_a R_a$$

$$E_g = V + (I_L + I_{sh}) R_a$$

$$I_{sh} = V / R_{sh} = 240 / 24 = 10 \text{ A.}$$

Substituting the values in the above expression,

$$254 = 240 + (I_L + 10) 0.04$$

$$I_L = 340 \text{ A}$$



- Q.12** The shaft output of a three-phase 60- Hz induction motor is 80 KW. The friction and windage losses are 920 W, the stator core loss is 4300 W and the stator copper loss is 2690 W. The rotor current and rotor resistance referred to stator are respectively 110 A and  $0.15 \Omega$  . If the slip is 3.8%, what is the percent efficiency?

(12)

**Ans:**

$$P_m = \text{output} = 80 \text{ KW}$$

$$\text{Windage and Friction losses} = 920 \text{ W}$$

$$\text{Stator core loss} = 4300 \text{ W}$$

$$\text{Stator copper loss} = 2690 \text{ W}$$

$$\text{Slip} = 3.8\%$$

$$\begin{aligned} \text{Gross mech output} &= P_m + \text{windage and friction losses} \\ &= 80 \text{ KW} + 920 \text{ W} \\ &= 80.92 \text{ KW} \end{aligned}$$

$$\text{rotor input / rotor gross output} = 1/(1-s)$$

$$\text{rotor input} = \text{rotor gross output} / (1-s) = 80.92 \text{ KW} / (1-0.038) = 84.11 \text{ KW}$$

we know that ;

$$\begin{aligned} \text{stator input} &= \text{rotor input} + \text{stator core loss} + \text{stator cu loss} \\ &= 84.11 \text{ KW} + 4300 \text{ W} + 2690 \text{ W} = 91.1 \text{ KW} \end{aligned}$$

$$\begin{aligned} \% \eta &= (\text{rotor output} / \text{stator input}) \times 100 \\ &= (80/91.1) \times 100 \text{ KW} \\ &= 87.81 \% \end{aligned}$$

- Q.13** A 6 pole 3 phase induction motor develops 30 H P including mechanical losses totalling 2 H P, at a speed of 950 RPM on 550 volt, 50 Hz mains. If the power factor is 0.88 and core losses are negligible, calculate:

- (i) The slip
- (ii) The rotor copper loss
- (iii) The total input power if the stator losses are 2 Kw
- (iv) The line current.

(6)

**Ans:**

$$P=6, 3\phi, \text{ output} = 30 \text{ H.P}$$

$$\text{Mech. loss} = 2 \text{ H.P}$$

$$N = 950 \text{ rpm}$$

$$V = 550 \text{ V}$$

$$f = 50 \text{ Hz.}$$

$$\cos\phi = 0.88$$

$$\text{slip, } S = (N_s - N_r)/N_s$$

$$N_s = 120 f / P = 120 \times 50 / 6 = 1000 \text{ r.p.m.}$$

$$\text{slip} = (1000 - 950) / 1000 = 0.05$$

$$\text{Rotor gross output} = \text{output} + \text{Mech. loss} = 30 + 2 = 32 \text{ H.P.}$$

$$\text{Rotor cu loss} / \text{Rotor gross output} = S / (1 - S)$$

$$\text{Rotor cu loss} = 0.05 \times 32 / 0.95 = 1.684 \text{ H.P.} = 1.684 \times 0.746 = 1.323 \text{ KW}$$

$$\text{Rotor input} = \text{Rotor gross output} / (1 - S) = 32 / 0.95 = 33.68 \text{ H.P.}$$

$$\text{Total input} = \text{Rotor input} + \text{cu loss} + \text{core loss}$$

$$(33.68 \times 745.7 \text{ W}) + 2000 \text{ W} + 0 = 27.115 \text{ KW}$$

$$\text{Line current} = \text{Total input} / (1.732 \times 550 \times 0.88)$$

$$= \mathbf{32.34 \text{ ampere}}$$

**Q.14** If the motor is fed from a 50 Hz 3 phase line, calculate:

- (i) number of poles
- (ii) slip at full load
- (iii) frequency of rotor voltage
- (iv) speed of rotor field wrt rotor
- (v) speed of rotor field wrt to stator

- (vi) speed of rotor field wrt stator field  
 (vii) speed of rotor at a slip of 10 percent. (6)

**Ans:**

- (i)  $N_s = 120f/P$   
 $P = 120 * 50/1000 = 6;$   
 (ii)  $S = (1000 - 950)/1000 = 0.05;$   
 (iii) frequency of rotor voltage  $= Sf = 0.05 \times 50 = 2.5$  Hz  
 (iv) Speed of rotor field w.r.t. rotor  $= (120Sf)/P = 120 \times 2.5/6 = 50$  rpm  
 (v) Speed of rotor field w.r.t stator  $= 950 + 50 = 1000$  rpm;  
 (vi) Speed of rotor field w.r.t stator field  $= 1000 - 1000 = 0$  rpm;  
 (vii) Speed of rotor at a slip of 10%  $= N_s (1 - S) = 900$  rpm;

**Q.15** Three single-phase, 50 kVA, 2300/ 230 V, 60 Hz transformers are connected to form a 3-phase, 4000V / 230-V transformer bank. The equivalent impedance of each transformer referred to low-voltage is  $0.012 + j 0.016 \Omega$ . The 3-phase transformer supplies a 3-phase, 120 kVA, 230 V, 0.85 power-factor (lagging) load.

- (i) Draw a schematic diagram showing the transformer connection.  
 (ii) Determine the winding currents of the transformer.  
 (iii) Determine the primary voltage (line to line) required. (3 x 3)

**Ans:** Given :

single phase ;  $P_0 = 50$  kVA ; 2300/230V, 60Hz

no. of transformers are 3 (three) to form a 3  $\Phi$  transformer

4000/230V ,  $P_0 = 120$  kVA , 230V and  $\cos\Phi = 0.85$  lagging

$Z_{02} = (0.012 + j 0.016) \Omega$  and

$Z_{01} = Z_{02} / K^2$

- (i) Schematic diagram to show transformer connection

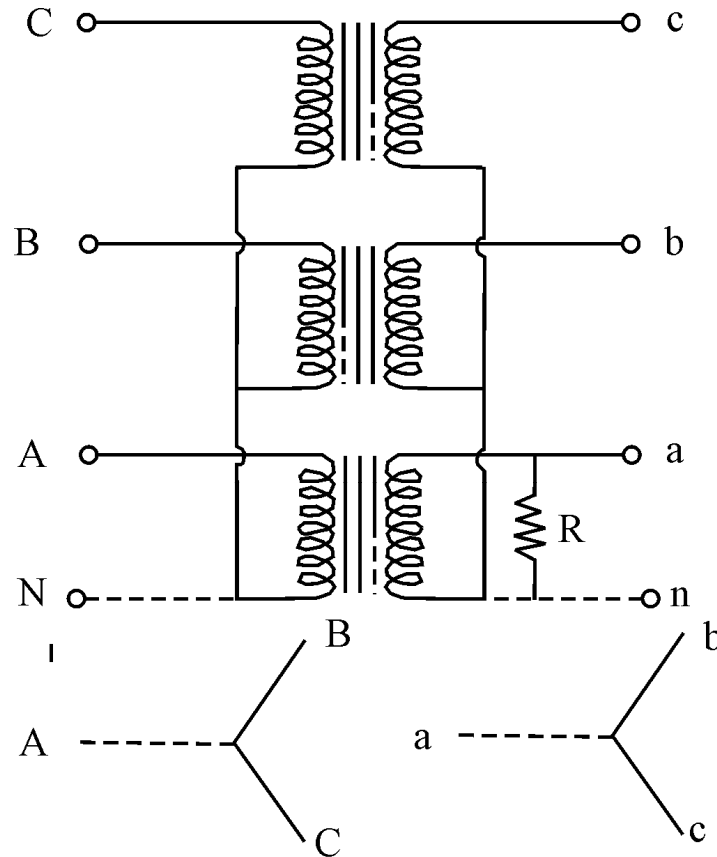

### 0° Angular Displacement

- (ii) Calculation of winding currents of transformer:

Given ,  $P_0 = 120 \text{ kVA}$

$$P_0 = \sqrt{3} V_L I_L \cos\Phi$$

$$I_L = I_{ph} ; \quad V_L = \sqrt{3} V_{ph} \quad (\text{star connection})$$

$$\begin{aligned} \therefore I_L &= 120 \times \cos\Phi \times 10^3 / \sqrt{3} V_L \cos\Phi \\ &= 120 \times 10^3 / \sqrt{3} \times 230 \\ &= 30.12 \text{ amp} \end{aligned}$$

$\therefore$  secondary line current = **30.12 amp.**

- (iii) Primary current  $I_1 = k I_2$   
 $= 230/4000 \times 30.12 = 1.732 \text{ amp.}$

Primary line voltage = **4000 volts.**

- Q.16** A pair of synchronous machines, on the same shaft, may be used to generate power at 60 Hz from the given source of power at 50 Hz. Determine the minimum number of poles that the individual machines could have for this type of operation and find the shaft-speed in r.p.m. (4+4)

**Ans:** Motor & generator (synchronous machine) are coupled. Therefore,

$$N_{S(m)} = N_{S(g)}$$

$$N_{S(m)} = 120 f_m / P_m \quad ; \quad N_{S(g)} = 120 f_g / P_g$$

Where :  $N_{S(m)}$  = synchronous speed of motor

$N_{S(g)}$  = synchronous speed of generator

$f_m$  = frequency of motor power

$f_g$  = frequency of generator power

$P_m$  = motor poles

$P_g$  = generator poles

$$\therefore 120 f_m / P_m = 120 f_g / P_g$$

$$120 \times 50 / P_m = 120 \times 60 / P_g$$

$$\therefore P_g / P_m = 6/5$$

$$P_g : P_m = 6 : 5$$

Therefore minimum requirement of poles for motor

$$P_m = 10 (5 \times 2)$$

$$P_g = 12 (6 \times 2)$$

Now synchronous speed or shaft speed =  $1200 \times 50 / 10 = 600 \text{ rpm}$

- Q.17** A 240V dc shunt motor has an armature resistance of 0.4 ohm and is running at the full-load speed of 600 r.p.m. with a full load current of 25A. The field current is constant; also a resistance of 1 ohm is added in series with the armature. Find the speed (i) at the full-load torque and (ii) at twice the full-load torque. (6)

**Ans:** In a DC shunt motor

$$V = 240V$$

$$R_a = 0.4\Omega$$

$$N_1 = 600\text{rpm (full load speed)}$$

$$I_a = 25A \text{ and } I_{sh} \text{ is constant}$$

$R = 1 \Omega$  added in series with armature

$$E_{b1} = V - I_a R_a$$

$$= 240 - 25 \times 0.4$$

$$= 230 \text{ volts}$$

$$E_{b2} = V - I_a (R_a + R)$$

$$= 240 - 25 (0.4 + 1)$$

$$= 201 \text{ volts}$$

$$\text{Now } N_1 / N_2 = E_{b1} / E_{b2} \times \Phi_2 / \Phi_1 \quad (\Phi_1 = \Phi_2 = \text{constant})$$

$$N_2 = N_1 \times E_{b2} / E_{b1} \quad \text{at full load torque}$$

$$= 600 \times 201 / 230$$

$$= 534.78$$

**∴ (i) speed of motor at full load = 535 rpm**

Now,

$$N_3 / N_1 = E_{b3} / E_{b1} \times \Phi_1 / \Phi_3 \quad (\Phi_1 = \Phi_2 = \Phi_3 = \text{constant})$$

And  $E_{b3}$  at twice the full load torque

$$\therefore I_{a2} = 2 I_a = 50 \text{ amp.}$$

$$\therefore E_{b3} = 240 - 50 (1 + 0.4) = 240 - 70 = 170 \text{ volts.}$$

$$N_3 = N_1 \times E_{b3} / E_{b1} = 600 \times 170 / 230 = 443.47 \text{ rpm}$$

**(ii) speed of motor at twice of load = 443 rpm**

**Q.18** A 400V, 4-pole, 50 Hz, 3-phase, 10 hp, star connected induction motor has a no load slip of 1% and full load slip of 4%. Find the following:

(i) Syn. speed (ii) no-load speed (iii) full-load speed.

(iv) frequency of rotor current at full-load (v) full-load torque. **(5 x 2 = 10)**

**Ans:** Given :

$$V_L = 400 \text{ volts ; } P = 4 \text{ nos, } 50 \text{ Hz,}$$

$$P_0 = 10 \text{ HP} = 735.5 \times 10 = 7355 \text{ watt}$$

$$\begin{aligned} \text{i. Synchronous speed } N_S &= 120 f / p \\ &= 120 \times 50 / 4 = 1500 \text{ rpm} \end{aligned}$$

$$\begin{aligned} \text{ii. No load speed at } s &= 0.01 \\ N_0 &= N_S (1 - s) = 1500 (1 - 0.01) \\ &= 1485 \text{ rpm} \end{aligned}$$

$$\begin{aligned} \text{iii. Full load speed at } s_f &= 0.04 \\ N_{fl} &= N_S (1 - s_f) = 1500 (1 - 0.04) \\ &= \mathbf{1440 \text{ rpm}} \end{aligned}$$

iv. Frequency of rotor current ( $f_r$ ) =  $s_f \cdot f = 0.04 \times 50$   
 $= 2.0 \text{ Hz}$

v. Full load torque at shaft

$$T_{Sh} = 9.55 P_0 / N_{fl}$$

$$= 9.55 \times 7355 / 1440$$

$$= 48.78 \text{ Nm}$$

**Q.19** A 2.2 kVA, 440 / 220 V, 50 Hz, step-down transformer has the following parameters referred to the primary side :  $R_{e1} = 3 \text{ ohms}$ ,  $X_{e1} = 4 \text{ ohms}$ ,  $R_{c1} = 2.5 \text{K ohms}$  and  $X_{m1} = 2 \text{Kohms}$ . The transformer is operating at full-load with a power-factor of 0.707 lagging. Determine the voltage regulation of the transformer. (10)

**Ans:**

Given :  $P_0 = 2.2 \text{ kVA}$ , 440/220 V, 50 Hz

$$R_{01} = 3 \Omega, X_{01} = 4 \Omega, R_m = 2.5 \text{k}\Omega, X_m = X_0 = 2 \text{k}\Omega$$

$$\cos \Phi = 0.707 \text{ lagging}$$

$$\text{Therefore } \sin \Phi = 0.707$$

Find Voltage regulation

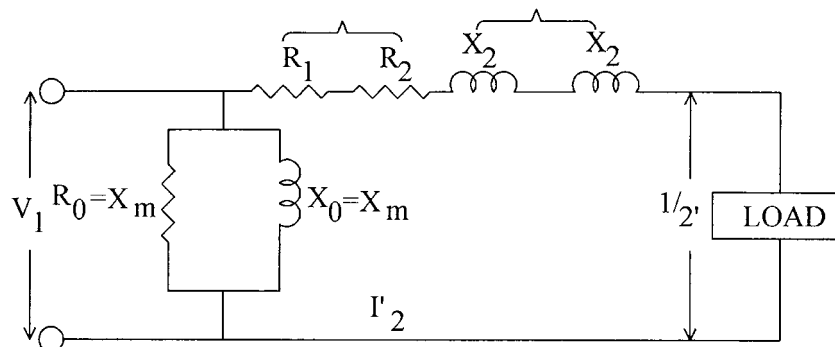

$$\cos \Phi = 0.707 ; \text{ therefore } \Phi = 45^\circ$$

$$(\text{Voltage drop}) = I_2 (R_{01} \cos \Phi + X_{01} \sin \Phi)$$

$$\text{and } I_2 = P_0 / V_2 \cos \Phi$$

$$= 2.2 \times 10^3 \times 0.707 / 220 \times 0.707$$

$$= 1 \times 10$$

$$I_2 = 10 \text{ A}$$

$$\text{Voltage drop} = 10 (3 \times 0.707 + 4 \times 0.707)$$

$$= 10 (4.950)$$

$$= 49.50 \text{ Volts}$$

$$\text{Therefore, Voltage regulation} = (\text{voltage drop} / V_2) \times 100$$

$$= (49.50 / 220) \times 100 = 22.50\%$$

- Q.20** A 9-kVA, 208 V, 3-phase, Y-connected, synchronous generator has a winding resistance of 0.1 ohm per phase and a synchronous reactance of 5.6 ohms per phase. Determine the voltage generated (exciting emf) by the machine when it is delivering full-load at 0.8 power-factor lagging at rated voltage. Calculate the voltage regulation for rated load at 0.8 power-factor (leading). (10)

**Ans:**

$$P_0 = \sqrt{3} V_L I_L \cos \Phi = 9 \text{ kVA}; \quad I_L = I_{ph} = P_0 / \sqrt{3} V_L \cos \Phi$$

$$V_L = 208 \text{ V}; \quad 3\Phi; \quad \text{Y connected synch. Gen.}$$

$$V_L = \sqrt{3} V_P; \quad I_L = I_{ph}; \quad \text{p.f} = 0.8 \quad V_{ph} = V_L / \sqrt{3} = 208 / \sqrt{3} = 120 \text{ V}$$

$$R_a = 0.1 \Omega / \text{ph.}, \quad X_a = 5.6 \Omega / \text{ph}$$

Find  $E_g = ?$ , Regulation = ?

$$I = P_0 / \sqrt{3} V_L \cos \Phi = (9 \times 10^3 \times 0.8) / (208 \times 0.8 \times 1.73) = 25 \text{ Amp.}$$

$$E_g = \sqrt{(V_P \cos \Phi + I R_a)^2 + (V \sin \Phi + I X_a)^2}$$

$$= \sqrt{(120 \times 0.8 + 25 \times 0.1)^2 + (120 \times 0.6 + 25 \times 5.6)^2}$$

$$E_g = \sqrt{(96 + 2.5)^2 + (72 + 140)^2}$$

$$= 233.76 \text{ Volts}$$

$$\% \text{ regulation} = (E_g - V / E_g) \times 100$$

$$= \{ (233.76 - 208) / 233.76 \} \times 100$$

$$= 11.02 \%$$

- Q.21** A 240-V, 20 hP, 850 r.p.m., shunt motor draws 72A when operating under rated conditions. The respective resistance of the armature and shunt field are 0.242 ohm and 95.2 ohms, respectively. Determine the percent reduction in the field flux required to obtain a speed of 1650 r.p.m., while drawing an armature current of 50.4 A. (9)

**Ans:**

Given  $V = 240 \text{ V}$

$P_i = 20 \text{ hp} = 20 \times 735.5 \text{ watt} = 14.71 \text{ kW}$

Find Change in flux = ?

$$I_{sh} = V / R_{sh} = 240 / 95.2 = 2.5 \text{ Amp}$$

$$N_1 = 850 \text{ rpm}; \quad I_L = 72 \text{ Amp. At rated load}$$

$$R_a = 0.242, \quad R_{sh} = 95.2 \Omega$$

$$N_2 = 1650 \text{ rpm}, \quad I_{a2} = 50.4 \text{ Amp}$$

$$\therefore E_{b1} = V - I_{a1} R_a$$

$$= 240 - 69.47 \times 0.242 = 223.19 \text{ volt}$$

and  $E_{b2} = V - I_{a2} R_a$

$$= 240 - 50.4 \times 0.242 = 227.80 \text{ volt}$$

$$E_{b1} / E_{b2} = N_1 \Phi_1 / N_2 \Phi_2$$



$$\begin{aligned}\text{Therefore, } \Phi_1 / \Phi_2 &= (E_{b1} / E_{b2}) \times (N_2 / N_1) \\ &= (223.19 / 227.80) \times (1650 / 850) = 36826.35/19363\end{aligned}$$

$$\Phi_1 / \Phi_2 = 1.90/1 = 19/10$$

$$\begin{aligned}\text{Therefore, change in flux } \Delta\Phi &= (\Phi_1 - \Phi_2) / \Phi_1 \times 100 \\ &= 9/19 \times 100 = \mathbf{47.37\%}\end{aligned}$$

**Q.22** The power input to the rotor of a 3-phase, 50 Hz, 6 Pole induction motor is 80 kW. The rotor emf makes 100 complete alternations per minute. Find

(i) the slip (ii) the motor speed and (iii) the mechanical power developed by the motor. (10)

**Ans:**

$$\text{Given } P_i = 80 \text{ kW ; } 50\text{Hz}$$

$$P = 6$$

$$\text{Rotor frequency } f' = (100/60) = 5/3 = 1.67 \text{ Hz}$$

$$S = f' / f = (5/3) / 50 = 0.033$$

$$\begin{aligned}\text{Mechanical Power developed by motor} &= (1-S) P_i \\ &= (1 - 1/30) \times 80 \text{ kW} = \mathbf{77.33\text{kW}}\end{aligned}$$

**Q.23** The parameters of the equivalent circuit of a 150-kVA, 2400/240V transformer are:

$$R_1=0.2\text{ohm}, R_2=2 \times 10^{-3} \text{ ohm}, X_1=0.45 \text{ ohm}, X_2= 4.5 \times 10^{-3} \text{ ohm},$$

$$R_i = 10 \text{ kohm}, X_m = 1.6 \text{ kohm as seen from 2400 volts side.}$$

Calculate:

(i) open circuit current, power and PF when LV side is excited at rated voltage. (8)

(ii) The voltage at which the HV side should be excited to conduct a short-circuit test (LV side) with full-load current flowing. What is the input power and its power factor? (8)

$$\text{Ans: Given Rating} = 150\text{kVA} \quad \therefore P_o = 150\text{kVA}$$

$$2400/240 \text{ V} \quad \therefore V_2 = 2400\text{V}; \quad V_1 = 240 \text{ V}$$

$$R_1 = 0.2\Omega \quad X_1 = 0.45\Omega$$

$$R_2 = 2 \times 10^{-3}\Omega \quad X_2 = 4.5 \times 10^{-3}\Omega$$

$$R_i = 10 \text{ k}\Omega \quad X_m = 1.6\text{k}\Omega$$

Find  $I_{20} = ?$ ,  $P_{20} = ?$ ,  $\cos \Phi_{20} = ?$ ,  
when L.V side is excited & H.V side is open circuit.

$$I_{FL} = ?$$
,  $P_i = ?$ ,  $\cos \Phi_i = ?$ ,

when H.V side is excited & short circuit at L.V side

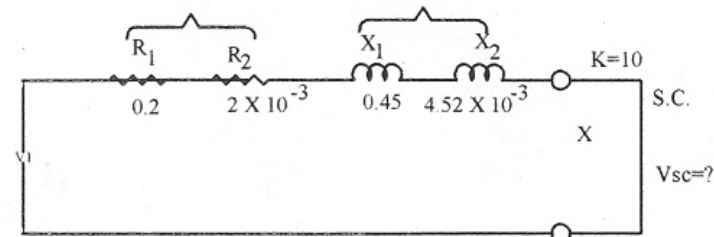
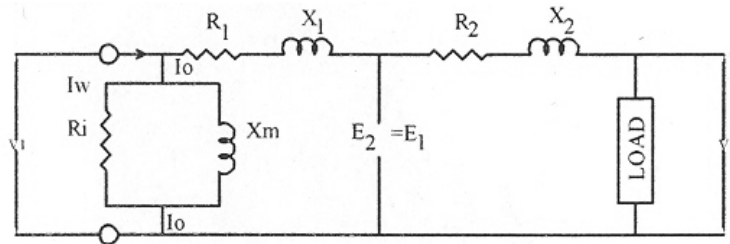

(i) Open Circuit power =  $V_1 I_0 \cos \Phi_0$   
 $= 240 \times I_0 \cos \Phi_0$  ... (1)

$I_0 = V_1 / Z_m$ ;  $V_1 = 240$  volts; ;

$Z_m = \sqrt{(10^2 + 1.6^2)} = 10.13 \text{ k}\Omega$  ( $Z_m = \sqrt{R_1^2 + X_m^2}$ )

$I_0 = 240 / 10.13 = 23.69 \times 10^{-3}$  Amp. Or 23.69 mA.

Power factor  $\cos \Phi_0 = R_i / Z_m$

$= 10 / 10.13$

**$\cos \Phi_0 = 0.987$**

Now open circuit power ( $W_{oi}$ ) =  $240 \times I_0 \times \cos \Phi_0$   
 $= 240 \times 23.69 \times 10^{-3} \times 0.987$

**$W_{oi} = 5.6 \text{ watt}$**

(ii)  $R_{01} = R_1 + R_2 / K^2$  ( $K = V_2 / V_1$ )

$= 0.2 + 2 \times 10^{-3} / 100$

$= 0.20002 \Omega$

$X_{01} = X_1 + X_2 / K^2$

$= 0.45 + 4.5 \times 10^{-3} / 100$

$= 0.450045 \Omega$

$Z_{01} = \sqrt{(R_{01}^2 + X_{01}^2)}$

$= 0.4924 \Omega$

Full load primary current ( $I_1$ ) =  $150000 / 2400 = 62.5$  Amp (max.)

Short circuit p.f. =  $R_{01} / Z_{01} = 0.20002 / 0.4924 = 0.406$

$V_{SC} = I_1 Z_{01} = 62.5 \times 0.4924 = 30.78$  Volt

$\therefore$  power absorbed =  $I_1^2 R_{01} = (62.5)^2 \times 0.20002 = 781.33$  Watt

$$\begin{aligned} \therefore \text{Input Power} &= \text{Out put power} + \text{power absorbed} \\ &= 150000 + 781.33 \\ &= 150781.33 \text{ W} \\ &= \mathbf{150.781 \text{ kW}} \end{aligned}$$

- Q.24** A 3300 Volts, delta connected motor has a synchronous reactance per phase (delta) of 18 ohm. It operates at a leading power factor of 0.707 when drawing 800 kW from the mains. Calculate its excitation emf. (8)

**Ans:**

$$\begin{aligned} \text{Given } V_L = V_{ph} = 3300\text{V} ; \cos\Phi = 0.707 \text{ leading} ; \\ P_i = 800 \text{ kw} = \sqrt{3} V_L I_L \cos\Phi \end{aligned}$$

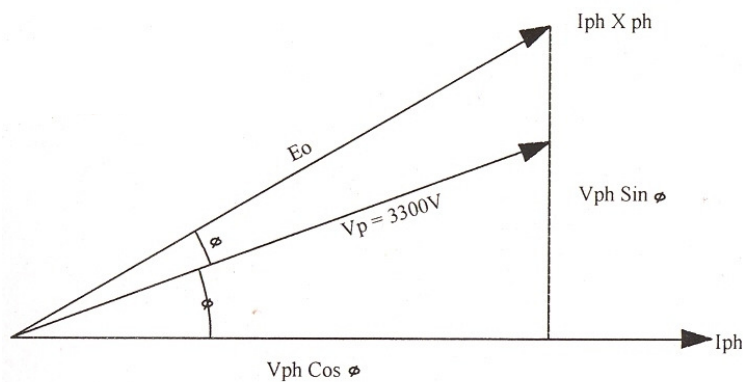

$$\therefore I_L = 800 \times 10^3 / \sqrt{3} \times 3300 \times 0.707$$

$$I_{ph} = I_L / \sqrt{3} = 114.30 \text{ Amp.}$$

Now, excitation e.m.f ( $E_0$ ) will be :

$$\begin{aligned} E_0 &= \sqrt{(V_{ph} \cos\Phi)^2 + (V_{ph} \sin\Phi + I_{ph} X_{ph})^2} \\ &= \sqrt{(3300 \times 0.707)^2 + (3300 \times 0.707 + 114.3 \times 18)^2} \\ &= 4.9712 \times 10^3 \text{ or } \mathbf{4971.22 \text{ Volts}} \end{aligned}$$

- Q.25** A 250 Volts dc shunt motor has  $R_f=150$  ohm and  $R_a = 0.6$  ohm. The motor operates on no-load with a full field flux at its base speed of 1000 rpm with  $I_a = 5$  Amps. If the machine drives a load requiring a torque of 100 Nm, calculate armature current and speed of the motor. (8)

**Ans:** Given  $V = 250 \text{ V}$

$$R_f = 150 \Omega$$

$$R_a = 0.6\Omega$$

i. operate no load and full load flux

$$N_o = 1000 \text{ rpm} \ \& \ I_{a0} = 5 \text{ amp.}$$

ii. On Load  $T_{af} = 100 \text{ Nm}$ ,

$I_{af}$  = armature full load current

$E_{b1}$  = Back emf at No load

$E_{b2}$  = Back emf at full load

$N_2$  = full load speed

Find  $I_{af} = ?$  ; &  $N_2 = ?$

At No load  $I_{a0} = 5 \text{ amp}$ .

$$\begin{aligned} E_{b1} &= V - I_a R_a & (1) \\ &= 250 - 5 \times 0.6 \\ &= 250 - 3 = \mathbf{247 \text{ volts}} \end{aligned}$$

$$\& E_{b2} = N_0 (\phi P Z / 60 A) \quad (2)$$

$$E_{b2} / N_0 = \phi P Z / 60 A = 247 / 1000 = 0.247$$

Now  $E_{b2}$  at full load

$$\begin{aligned} E_{b2} &= N_0 (\phi P Z / 60 A) = V - I_{af} R_a \\ E_{b2} &= N_2 \times 0.247 = 250 - I_{af} \times 0.6 & (3) \end{aligned}$$

Now  $T_a$  at no load

$$\begin{aligned} T_{a0} &= 9.55 E_{b1} I_{a0} / N_0 \\ &= 9.55 \times 247 \times 5 / 1000 = \mathbf{11.79 \text{ Nm}} \end{aligned}$$

$$T_1 / T_2 = I_1 / I_2$$

$$T_{a0} / T_{af} = I_{a0} / I_{af}$$

$$11.75 / 100 = 5 / I_{af}$$

$$\therefore I_{af} = 500 / 11.79 = \mathbf{42.41 \text{ amp}}$$

Therefore, armature current at full load = 42.41 amp

Put this value in equation (3)

$$N_2 \times 0.247 = 250 - 42.41 \times 0.6$$

$$\therefore N_2 = 224.55 / 0.247 = 909.13 \text{ rpm}$$

$$\therefore \text{Full load speed} = \mathbf{909 \text{ rpm}}$$

**Q.26** A 400Volts, 1450 rpm, 50 Hz, wound-rotor induction motor has the following circuit model parameters.

$$R_1 = 0.3 \text{ ohm} \quad R_2 = 0.25 \text{ ohm}$$

$$X_1 = X_2 = 0.6 \text{ ohm} \quad X_m = 35 \text{ ohm}$$

Rotational loss = 1500 W. Calculate the starting torque and current when the motor is started direct on full voltage. (8)

Ans:

$$V = 400\text{V}; \quad N = 1450 \text{ rpm}; \quad f = 50 \text{ Hz}$$

$$R_1 = 0.3 \Omega \quad R_2' = 0.25 \Omega; \quad X_1 = X_2' = 0.6 \Omega; \quad X_0 = 35 \Omega$$

Rotational losses = 1500 W

$$\text{Find starting torque } T_1 = ? \quad I_f = ?$$

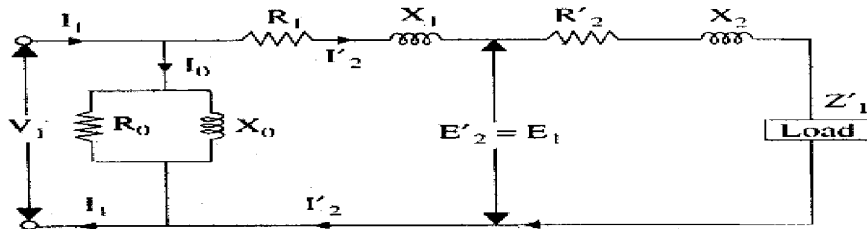

$$R_{01} = R_1 + R_2' = 0.3 + 0.25 = 0.55 \Omega$$

$$X_{01} = X_1 + X_2' = 0.6 + 0.6 = 1.2 \Omega$$

$$Z_{01} = \sqrt{(R_{01})^2 + (X_{01})^2} = \sqrt{0.55^2 + 1.2^2} = 1.32 \Omega$$

$$S = R_2' / \sqrt{R_1^2 + (X_1 + X_2')^2} = 0.25 / \sqrt{0.3^2 + (0.6 + 0.6)^2}$$

$$= 0.25 / \sqrt{1.53} = 0.2021$$

$$\therefore N_s = N / (1 - S) = 1450 / (1 - 0.2) = 1812 \text{ rpm}$$

$$I_2' = I_f = V_{ph} / \sqrt{(R_1 + R_2')^2 + (X_1 + X_2')^2}$$

$$= \frac{400/\sqrt{3}}{\sqrt{(0.55)^2 + (1.2)^2}} \quad (V_{ph} = V_L / \sqrt{3} \text{ let motor Y connected})$$

$$\text{Or } I_f = V / Z_{01} = \frac{400/\sqrt{3}}{1.32}$$

$$= 175.16 \text{ amp.}$$

Torque developed by rotor

$$T_g = \frac{(3 I_2' R_2') / S}{2\pi N_s / 60}$$

$$\text{Or } T_g = \frac{(3 I_2' R_2') \{ (1 - S) / S \}}{2\pi N / 60} \quad \text{Nm} \quad (N = (1 - S) N_s)$$

$$= \frac{3 \times (175.16) \times 0.25 \times (0.8/0.2)}{(2 \times 3.14 \times 1450) / 60}$$

$$= 606.86 \text{ Nm}$$

$$T_{\text{Shaft}} = \frac{(3 I_2' R_2') \{ (1 - S) / S \}}{2\pi N / 60} - \text{rotational losses} \quad \text{Nm}$$

$$= 606.86 - 1500/151.67$$

$$= \mathbf{596.97 \text{ Nm}}$$

$$(N = (1-S)N_s)$$

**Q.27** A universal motor (ac-operated) has a 2-pole armature with 960 conductors. At a certain load the motor speed is 5000 rpm and the armature current is 4.6 Amps, the armature terminal voltage and input power are respectively 100 Volts and 300 Watts.

Compute the following, assuming an armature resistance of 3.5 ohm.

- (i) Effective armature reactance.  
 (ii) Maximum value of useful flux/pole. (8)

**Ans:**  $P = 2$ ;  $Z = 960$ ;  $N = 5000$

$$I_i = I_a = 4.6 \text{ amp ; } V_1 = 100 \text{ volts}$$

$$P_i = 300\text{W find } X_a \text{ and } \phi_m = ?$$

$$P_1 = V_1 I_1 \cos \phi$$

$$\therefore \cos \phi = P_1 / V_1 I_1$$

$$= 300 / 100 \times 4.6 = 0.652$$

$$E_{bdc} = V - I_a R_a \text{ or } (N\phi PZ / 60A)$$

$$= 100 - 4.6 \times 3.5$$

$$= 100 - 16.1 = 83.9 \text{ volts}$$

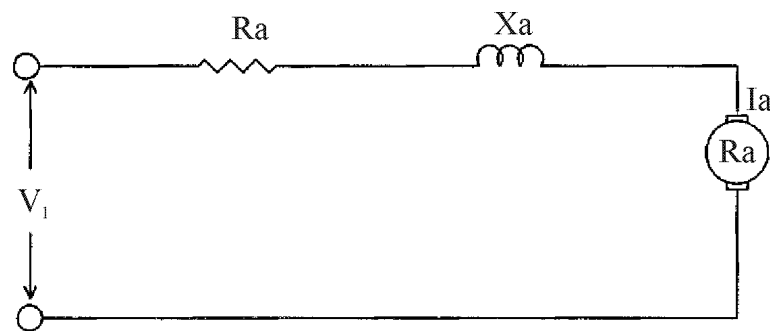

$$E_{bac} = V \cos \phi - I_a R_a$$

$$= 100 \times 0.652 - 4.6 \times 3.5 = 49.11 \text{ volts}$$

$$\text{And } V^2 = ((E_{bac} + I_a R_a)^2 + (I_a X_a)^2$$

$$(4.6 X_a)^2 = 100^2 - (65.2)^2$$

$$21.16 X_a^2 = 5749$$

$$X_a = 16.48 \text{ ohms}$$

$$E_{\text{bdc}} = (N\phi_m PZ / 60A)$$

$$\therefore \phi_m = E_{\text{bdc}} \times 60 \text{ A} / NPZ$$

Flux

$$\therefore \phi_m = 83.9 \times 60 \times 2 / 5000 \times 2 \times 960 \quad (A=P)$$

$$= 1.048 \times 10^{-3} \text{ wb}$$

- Q.28** A single phase 50 Hz generator supplies an inductive load of 5,000kW at a power factor of 0.707 lagging by means of an overhead transmission line 20 km long. The line resistance and inductance are 0.0195 ohm and 0.63 mH per km. The voltage at the receiving end is required to be kept constant at 10 kV. Find the sending end voltage and voltage regulation of the line. (8)

**Ans:**

Given 1  $\phi$ , 50 Hz ;  $\cos\phi = 0.707$  lagging

Transmission length = 20 km

Generator supply inductive load = 5000kW = kVAR

R = 0.0195 ohms/km , L = 0.63 mH

$V_R = 10\text{kV}$

Find sending end voltage  $V_S = ?$  & % regulation =?; distance = 20km

$\Delta V = V_S - V_R$  ( drop in line )

$(V_S - V_R) = RP + XQ / V_R$  { Active Power (P) = Reactive Power (Q) }

$$= 0.0195 \times 20 \times 5000 \times 10^3 + 3.96 \times 5000 \times 10^{-3} / 10 \times 10^3$$

$$V_S = \{0.0195 \times 20 \times 5000 \times 10^3 + 3.96 \times 5000 \times 10^{-3} / 10 \times 10^3\} + 10 \times 10^3 \text{ volts}$$

$$= 1.2175 \times 10^4 \text{ volts}$$

$$= 12.175 \text{ kVolts}$$

$$\% \text{ Regulation} = (V_S - V_R) / V_S \times 100$$

$$= 17.86\%$$

- Q.29** A 37.7 HP, 220 V d.c shunt motor with a full load speed of 535 rpm is to be braked by plugging. Estimate the value of resistance which should be placed in series with it to limit the initial current to 200 A. (8)

**Ans:**

$$P_0 = 37.7 \text{ HP} = 37.7 \times 735.5 \text{ W} = 27.73 \text{ kW}$$

$$N_L = 535 \text{ rpm braked by plugging ; } I_a = 200 \text{ A}$$

$$V = 220 \text{ v}$$

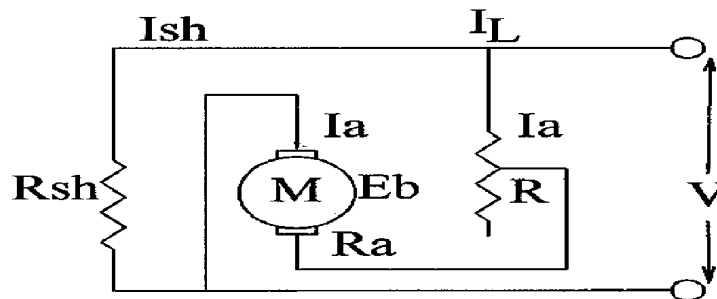

Under plugging :

$$I_a = V + E_b / (R + R_a)$$

$$\text{and } E_b = 27.73 \times 10^3 / 200 \quad (\text{assume negligible losses})$$

$$= 138.65 \text{ Volts}$$

$$200 = 220 + 138.65 / (R + R_a)$$

$$R + R_a = 358.65 / 200 = \mathbf{1.79 \text{ ohm}}$$

R = value of added resistance in series with armature resistance

$R_a$  = armature resistance

- Q.30** The losses of a 30 kVA, 2000/200 V transformer are

Iron losses: 360 W

Full load copper losses : 480 W

Calculate the efficiency at unity power factor for (i) full load and (ii) half load. Also determine the load for maximum efficiency; also compute the iron and copper losses for this maximum efficiency condition. (12)

**Ans:**

Given: 30 kVA, 2000/ 200 Volts,  $W_i = 360 \text{ W}$

$$W_c = 480 \text{ W}, \cos\Phi = 1$$

(i) at full load unity p.f.

$$\text{Total losses} = 360 + 480 = 840 \text{ W}$$

$$\text{At Full load, output at unity p.f.} = 30 \times 1 = 30 \text{ kW}$$

$$\text{Therefore, Efficiency} = (30 / (30 + 0.84)) \times 100$$



$$= 97.28 \%$$

(ii) At half load and unity p.f.

$$W_c = 480 \times (\frac{1}{2})^2 = 120 \text{ W}$$

$$W_i = 360 \text{ W}$$

$$\text{Total losses} = 360 + 120 = 480 \text{ W}$$

$$\text{At half load, output at unity p.f} = 30/2 \times 1 = 15 \text{ kW}$$

$$\text{Therefore, Efficiency} = (15 / (15 + 0.48)) \times 100$$

$$= 96.90 \%$$

(iii) The load for maximum efficiency and condition for max. efficiency.

$$\text{Efficiency } (\eta) = (V_1 I_1 \cos \Phi - \text{losses}) / V_1 I_1 \cos \Phi$$

$$= (V_1 I_1 \cos \Phi - I_1^2 R_{01} - W_i) / V_1 I_1 \cos \Phi$$

$$= 1 - \frac{I_1 R_{01}}{V_1 I_1 \cos \Phi} - \frac{W_i}{V_1 I_1 \cos \Phi}$$

Differentiating above equation for maximum efficiency

Therefore,

$$\frac{dn}{dI_1} = 0 - \frac{R_{01}}{V_1 \cos \Phi} - \frac{W_i}{V_1 I_1 \cos \Phi} = 0$$

and

$$\frac{R_{01}}{V_1 \cos \Phi} = \frac{W_i}{V_1 I_1 \cos \Phi}$$

Therefore,

$$W_i = W_c$$

and load current,  $I_1 = (\sqrt{W_i / R_{02}})$

**Q.31** A 22 KV, 3 phase star-connected turbo- alternator with a synchronous impedance of 1.4  $\Omega$ /phase is delivering 240 MW at unity p.f. to a 22 KV grid. If the excitation is increased by 25%, then the turbine power is increased till the machine delivers 280 MW. Calculate the new current and power factor. (10)

**Ans:**

Given :  $V_L = 33 \text{ kV}$ , 3 phase, star connected Synchronous Generator

$$\therefore V_{ph} = 33 / \sqrt{3} = 19.1 \text{ kV}$$

$$Z_{ph} = 1.4 \Omega$$

$$P_{01} = 240 \text{ MW} = 240 \times 10^6 \text{ Watt}$$

$$\cos \Phi_1 = 1$$

$$\Psi_2 = 1.25 \Psi_1 \quad (\text{Flux / excitation})$$

$$P_{02} = 280 \text{ MW} = 280 \times 10^6 \text{ Watt}$$

Find  $I_{L2} = ?$  ;  $\cos \Phi_2 = ?$

$$E_{g1} / \text{ph} = V_{ph1} + I_{ph1} Z_{ph}$$

$$= (33 \times 10^3 / \sqrt{3}) + \{(240 \times 10^6 / \sqrt{3} \times 33 \times 10^3) \times 1.4\}$$

$$(P_{01} = \sqrt{3} V_{L1} I_{L1} \cos \Phi_1 \text{ \& } I_{L1} = I_{ph1})$$

$$= 24.98 \times 10^3 \text{ volts}$$

$$\approx 25 \text{ kV}$$

Now

$$\frac{E_{g1/ph}}{E_{g2/ph}} = \frac{\Psi_1}{\Psi_2}$$

$$\Psi_2 = 1.25\Psi_1, \text{ due to 25\% increased excitation )}$$

$$E_{g2/ph} = E_{g1/ph} * \frac{\Psi_2}{\Psi_1}$$

$$\therefore E_{g2/ph} = 31.23 \text{ kV}$$

$$\text{or } E_{g2/ph} = V_{ph} + I_2 Z_{ph}$$

$$I_{2ph} = \frac{E_{g2} - V}{Z_{ph}} = \frac{12.125 \times 10^3}{1.4}$$

$$= \mathbf{8.66 \text{ kA}}$$

$$\text{Now } P_{02} = \sqrt{3} V_L I_{L2} \cos \Phi_2 \text{ ( } I_{L2} = I_{ph2} : V_L = V_{L1} = V_{L2} ; P_{02} = 280 \text{ MW )}$$

$$\cos \Phi_2 = \frac{P_{02}}{\sqrt{3} V_L I_{L2}}$$

$$= \frac{280 \times 10^6}{\sqrt{3} \times 33 \times 8.66 \times 10^6}$$

$$= 280 / 495$$

$$= \mathbf{0.565 \text{ leading}}$$

- Q.32** A 250 V DC shunt motor has an armature resistance of 0.55  $\Omega$  and runs with a full load armature current of 30A. The field current remaining constant, if an additional resistance of 0.75  $\Omega$  is added in series with the armature, the motor attains a speed of 633 rpm. If now the armature resistance is restored back to 0.55  $\Omega$ , find the speed with (i) full load and (ii) twice full load torque. (12)

**Ans:**

Given  $R_a = 0.55 \Omega$ ,  
 $R_T = 0.75$  additional resistance in series with armature  
 $V = 250\text{V}$   
 $I_a = 30\text{A}$  at full load                      Then  $N_2 = 633 \text{ rpm}$   
 $I_{sh} = \text{Constt.}$   
 Find  $N_1 = ?$  at full load ;     $N_3 = ?$  at double load  
 $N_1 \propto V - I_{a1}R_a$

$$N_2 \propto V - I_{a2}(R_T + R_a) \quad I_{a1} = I_{a2} = 30 \text{ Amp; } I_f = \text{constt.}$$

$$\therefore \frac{N_1}{N_2} = \frac{V - I_{a1}R_a}{V - I_{a2}R_a}$$

$$\therefore = \frac{250 - 30 \times 0.55}{250 - 30(0.55 + 0.75)} = \frac{233.5}{211}$$

$$\frac{N_2}{N_1} = 1.106$$

$$N_1 = N_2 * 1.106 = 700.5$$

$$N_1 = \mathbf{701 \text{ r.p.m at full load without } R_t}$$

Speed  $N_3$  at twice full load torque without  $R_t$

$$\frac{N_1}{N_3} = \frac{V - I_{a1} R_a}{V - I_{a3} R_a}$$

$$\therefore = \frac{250 - 30 \times 0.55}{250 - 60 \times 0.55} = \frac{233.5}{217}$$

$$\frac{N_1}{N_3} = 1.076$$

$$\therefore N_3 = N_1 / 1.076 = 701 / 1.076 = 651 \text{ rpm}$$

**Speed of motor at twice full load torque = 651 rpm**

**Q.33** A 4-pole, 3 phase, 400 V, 50 Hz, induction motor has the following parameters for its circuit model (rotor quantities referred to the stator side) on an equivalent-star basis:

$R_1 = 1.6 \Omega$ ,  $X_1 = 2.4 \Omega$ ,  $R_2' = 0.48 \Omega$ ,  $X_2' = 1.2 \Omega$  and  $X_m = 40 \Omega$ . Rotational losses are 720 W. Neglect stator copper losses. For a speed of 1470 rpm, calculate the input current, input power factor, net mechanical power output, torque and efficiency.

(12)

**Ans:**

Given:

$$P = 4$$

$$V_L = 400 \text{ V}$$

$$f = 50 \text{ Hz}$$

$$R_1 = 1.6 \Omega, X_1 = 2.4 \Omega; R_2' = 0.48 \Omega; X_2' = 1.2 \Omega$$

$$X_m = X_0 = 40 \Omega$$

$$\text{Rotational losses} = 720 \text{ W}; \quad W_i = 0 \text{ Watt}$$

$$N = 1470 \text{ rpm}$$

$$\text{Find } I_1 = ?; \quad \cos \Phi = ?; \quad P_{mo} = ?; \quad T_s = ?; \quad \eta = ?$$

$$N_s = 120 f / P = 120 \times 50 / 4 = 1500 \text{ rpm}$$

$$\text{Therefore, } s = (N_s - N) / N_s = (1500 - 1470) / 1500 = 0.02$$

$$\text{Input current } I_1 = V_1 / Z_{01}$$

$$V_1 = 400 \text{ V}; \quad \text{Let } R_o \text{ is negligible}$$

$Z_{01} = Z_1 + Z_{AB}$ ; where  $Z_{AB}$  is the impedance between point A and B

$$Z_1 = (R_1 + jX_1) = (1.6 + j 2.4)$$

$$Z_{AB} = j X_m [ R_2'/S + jX_2' ] / \{ (R_2'/S) + jX_2' + j X_m \}$$

$$= j40 (0.48 / 0.02 + j1.2) / \{ 0.48 / 0.02 + j (1.2 + 40) \}$$

$$= \{ j40 (24 + j 1.2) \} / [24 + j (41.2)]$$

$$= \{ (j960 - 48) \times (24 - j41.2) \} / \{ (24 + j41.2)(24 - j41.2) \}$$

$$= \{ j960 \times 24 + 960 \times 41.2 - 48 \times 24 + j 48 \times 41.2 \} / \{ (24)^2 + (41.2)^2 \}$$

$$= j 23040 + 38400 + j 1977.6$$

$$= (38400 + j 25017.6) / (576 + 1697.44)$$

$$= 16.89 + j 11$$

$$Z_{AB} = 16.9 + j11 = 20.16 \angle 33^\circ$$

$$\therefore Z_{01} = (1.6 + j 2.4) + (16.9 + j11) = 18.5 + j13.4 = 22.84 \angle 35.9^\circ$$

$$(i) \therefore I_1 = V_1 / Z_{01} = (400 / \sqrt{3}) \angle 0^\circ / 22.84 \angle 35.9^\circ = 10.24 \angle -35.9^\circ$$

$$(ii) \text{ p.f} = \cos \Phi$$

$$= \cos 35.9^\circ$$

$$= 0.81$$

$$(iii) \text{ Mech. total power} = (1-S)P_2 ; \text{ Where } P_2 \text{ is the power of air gap}$$

$$= (1-0.02) 3I_2'^2 (R_2' / S)$$

$$= 0.98 \times 3 \times I_1^2 R_{AB}$$

$$= 0.98 \times 3 \times (10.24)^2 + 16.9$$

$$= 5209.95$$

$$= 5210 \text{ Watt}$$

$$\text{Net Mech. Power} = \text{Total Mechanical Power} - \text{Rotational Losses}$$

$$= 5210 - 720$$

$$P_{mo} = 4490 \text{ Watt}$$

$$(iv) \text{ Net Torque} = P_{mo} / (2 \pi N / 60)$$

$$= 4490 / (2 \times 3.14 \times 1470 / 60)$$

$$N = 1500 (1-0.02) = \mathbf{1470 \text{ rpm}}$$

$$= 4490 \times 60 / 6.28 \times 1470 = 29.18 \text{ Nm}$$

$$\mathbf{T_s = 29.18 \text{ Nm}}$$

$$(v) \text{ output power} = 4490$$

$$(a) \text{ Stator 'core' losses } W_1 = 0$$

$$(b) \text{ Stator 'Cu' losses} = 3I_1^2 R_1 = 3 \times (10.24)^2 \times 1.6$$

$$= 3 \times 167.77$$

$$= \mathbf{503.31 \text{ Watt}}$$

- (c) Rotor 'Cu' losses =  $3I_2^2 R_2 = SP_2$   
 $= 0.02 \times 3 \times (10.24)^2 \times 16.9$   
 $= \mathbf{106.32 \text{ Watt}}$
- (d) Rotational losses =  $\mathbf{720 \text{ Watt}}$

Therefore: Efficiency ( $\eta$ ) = (output / output + losses) x 100

$$= 4490 \times 100 / (4490 + (0+503.31+106.32+720))$$

$$= \mathbf{77.39 \%}$$

**Q.34** A universal motor has a 2-pole armature with 1020 conductors. When it is operated on load with a.c. supply with an armature voltage of 150, the motor speed is 5400 RPM. The other data is:

Input power : 360 W

Armature current : 5.2 A

Armature resistance: 5.5  $\Omega$

Compute (i) the effective armature reactance and (ii) maximum value of armature flux per pole. (10)

**Ans:** Given:

$$P=2; \quad V_a = 150 \text{ V}; \quad N = 5400 \text{ rpm}$$

$$Z=1020; \quad P_i = 360 \text{ MW}; \quad I_a = 5.2\text{A};$$

$$R_a = 5.5\Omega$$

Find  $X_a = ?$ ;  $\Phi_{\max}$  per pole=?

$$f = NP/120 = 5400 \times 2 / 120 = 90\text{Hz}$$

$$E_{abc} = V_a - I_a R_a$$

$$= 150 - 5.2 \times 5.5$$

$$= 121.4 \text{ V}$$

$$\text{Now } E_b = N\Phi PZ/60A$$

$$\therefore \Phi_m = E_b \times 60 \text{ A} / NPZ$$

$$= 121.4 \times 60 \times 2 / (5400 \times 2 \times 1020)$$

$$= 1.4568 \times 10^{-4} / 1.102 \times 10^6$$

$$= 1.322 \times 10^{-2} \text{ wb per pole}$$

$$\text{Now } I_a = V_a / Z_a$$

$$\therefore Z_a = V_a / I_a = 150 / 5.2 = 28.84 \Omega$$

$$Z_a = \sqrt{R_a^2 + X_a^2} = 28.84 \Omega$$

$$\therefore R_a^2 + X_a^2 = 832 \Omega$$

$$\begin{aligned} X_a^2 &= 832 - R_a^2 \\ &= 832 - 5.5^2 \\ &= 801.75 \end{aligned}$$

$$\therefore X_a = 28.32 \Omega$$

**Q.35** A 50 KVA, 2300/230 V, 60 Hz transformer has a high voltage winding resistance of  $0.65 \Omega$  and a low-voltage winding resistance of  $0.0065 \Omega$ . Laboratory tests showed the following results:

Open circuit test:  $V = 230 \text{ V}$ ,  $I = 5.7 \text{ A}$ ,  $P = 190 \text{ W}$

Short circuit test:  $V = 41.5 \text{ V}$ ,  $I = 21.7 \text{ A}$ ,  $P = \text{No wattmeter was used}$ .

- (a) Compute the value of primary voltage needed to give rated secondary voltage when the transformer is connected as a step-up one and is delivering 50 KVA at a power factor of 0.8 lagging. (12)
- (b) Compute the efficiency under conditions of part (a). (4)

**Ans:**

Given :  $P_0 = 50 \text{ kVA}$ ,  $V_1 = 2300 \text{ V}$ ,  $V_2 = 230 \text{ V}$ ,  $f = 60 \text{ Hz}$   
 $R_1 = 0.65 \Omega$  (H.V.Side),  $R_2 = 0.0065 \Omega$  (L.V Side)

Lab test: O.C (H.V.Side) :  $V = 230 \text{ V}$ ,  $I = 5.7 \text{ A}$ ,  $P = 190 \text{ watt}$   
 S.C (L.V.Side), :  $V = 41.5 \text{ V}$ ,  $I = 21.7 \text{ A}$ ,  $P = ? \text{ watt}$

Find (a)  $V_1$  for rated  $V_2$  when acts as step up transformer and delivering 50kVA at  $\cos \Phi = 0.8$   
 (b) efficiency

At S.C test

$$Z_{02} = V_{SC} / I_2 = 41.5 / 21.7 = 1.912 \Omega \text{ \& } K = 1/10$$

$$\therefore Z_{01} = Z_{02} / K^2 = 1.912 \times 10^2 = 191.2 \Omega$$

$$R_{01} = R_1 + R_2' = 0.65 + 0.0065/100 \text{ (} K = 1/10, \text{ H.V side is } R_2)$$

$$R_{01} = 0.13 \Omega$$

$$R_{02} = R_{01} \times K^2 = 0.13 / 100 = 0.0013 \Omega$$

$$\text{Now } X_{01} = \sqrt{Z_{01}^2 - R_{01}^2} = \sqrt{(191.2)^2 - (0.13)^2}$$

$$X_{01} = 191.2 \Omega$$

$$\text{\& } X_{02} = \sqrt{Z_{02}^2 - R_{02}^2} = \sqrt{(1.912)^2 - (0.0013)^2}$$

$$X_{01} = 1.912 \Omega$$

Total transformer voltage drop referred to secondary

$$VD_2 = I_2 ( R_{02} \cos \Phi_2 + X_{02} \sin \Phi_2)$$

$$= 21.7 ( 0.0013 \times 0.8 + 1.92 \times 0.6) = 21.7 ( 1.153)$$

$$= 25.02 \text{ Volts}$$

$$\therefore V_1' = V_1 + VD_2 = 230 + 25.02 = 255.02 \text{ Volts.}$$

$\therefore V_1 = 255.02$  volts for  $V_2 = 2300$  volts rated value as step up.

Efficiency of Transformer = output/ Input

$$\begin{aligned}
 &= \frac{50 \times 1000 \times 0.8}{\text{output} + \text{losses (core Losses} + \text{Cu losses)}} \\
 &= \frac{40000}{40000 + 190 + I_1^2 R_1 + I_2^2 R_2} \\
 &= \frac{40000}{40000 + 190 + (5.7)^2 \times 0.65 + (21.7)^2 \times 0.0065} \\
 &\quad \text{(note: low voltage winding is short circuited)} \\
 &= \frac{40000}{40000 + 32.49 \times 0.65 + 470.89 \times 0.0065} \\
 &= \frac{40000}{40000 + 21.12 + 3.06} \\
 &= \mathbf{99.93\%}
 \end{aligned}$$

**Q.36** A three-phase, 335-hp, 2000V, six pole, 60 Hz, Y-connected squirrel-cage induction motor has the following parameters per phase that are applicable at normal slips:

$$r_1 = 0.2\Omega. \quad x_1 = x_2^1 = 0.707\Omega,$$

$$r_2^1 = 0.203\Omega. \quad r_c = 450\Omega$$

$$x_\phi = 77\Omega$$

The rotational losses are 4100 watts. Using the approximate equivalent circuit, compute for a slip of 1.5%.

- the line power factor and current.
- developed torque.
- efficiency.

(8+4+4)

**Ans:**

Given: 3 phase, 335 HP, 50 Hz,  $V = 2000$ V Induction motor

$$P_0 = 335 \times 735.5 \text{ watt} \quad \text{Rotational losses} = 4100 \text{ watt}; \text{ Slip } (s) = 0.015$$

$P = 6$  nos., Y connected

$$\therefore I_L = I_{ph} \quad \& \quad V_L = \sqrt{3} V_{ph}$$

$$V_{ph} = V_L / \sqrt{3} = 2000 / \sqrt{3} = 1154.70 \text{ volts}$$

Find : p.f = ? , Line current  $I_L = ?$  ,  $T_g = ?$  , and  $\eta = ?$

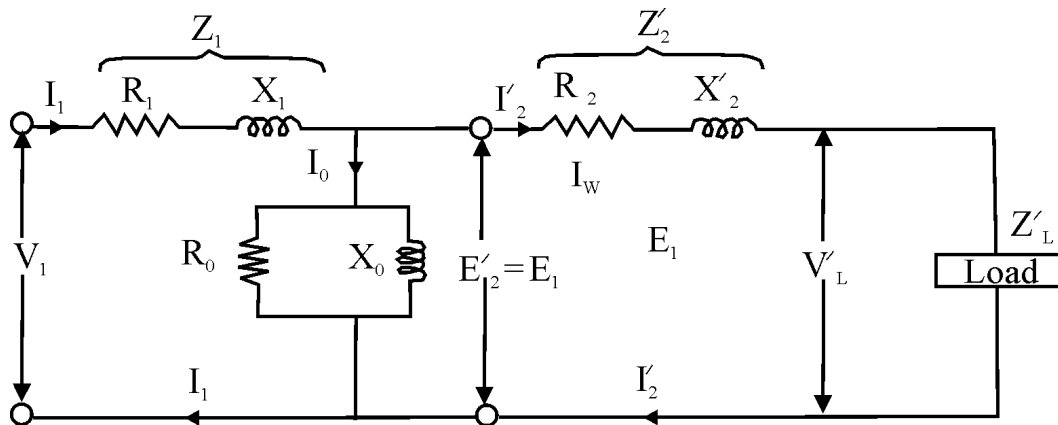

Sol: (i)  $R_1 = 0.2 \Omega$ ,  $R_2' = 0.203 \Omega$   
 $X_1 = X_2' = 0.707 \Omega$   
 $x_0 = 77 \Omega$ ,  $R_0 = 450 \Omega$   
 $R_{01} = R_1 + R_2' = 0.2 + 0.203 = 0.403 \Omega$   
 $X_{01} = X_1 + X_2' = 0.707 + 0.707 = 1.414 \Omega$   
 $Z_{01} = \sqrt{R_{01}^2 + X_{01}^2} = \sqrt{(0.403)^2 + (1.414)^2} = 1.47 \Omega$

Load current  $I_2' = I_L$

$$\begin{aligned} \therefore I_2' &= V_{Ph} / (R_1 + R_2' / s) + j(X_1 + X_2') \\ &= 1154.7 \angle 0^\circ / (0.2 + 0.203/0.015) + j(0.707 + 0.707) \\ &= 1154.7 \angle 0^\circ / 13.733 + j 1.414 = 1154.7 \angle 0^\circ / 13.80 \angle 5.88^\circ \\ &= 83.67 \angle -5.88^\circ \end{aligned}$$

$\therefore I_L = 83.67 \text{ Amp.}$

P.f =  $\cos(-5.88^\circ) = -0.99$  lagging

(ii) Torque generated ( $T_g$ ) or developed =  $(9.55 \times 3 I_2'^2 R_2' / s) / N_s$   
 $\{N_s = 120 f / p = 120 \times 50 / 6 = 1000 \text{ rpm}\}$   
 $= (9.55 \times 3 \times (83.67)^2 \times 0.203 / 0.015) / 1000$   
 $T_g = 2.714 \times 10^3 \text{ Nm}$

(iii) Efficiency of machine = output / output + losses  
Total losses = Rotational losses + rotor 'Cu' losses + stator 'Cu' losses  
Rotational losses = 4100 watt = 4.1 kW  
rotor 'Cu' losses =  $3 I_2'^2 + R_2 = 3 \times (83.67)^2 \times 0.203 = 4.26 \text{ kW}$   
stator 'Cu' losses =  $3 I_1'^2 R_1 = 3 \times (86.2)^2 \times 0.2 = 4.458 \text{ kwatt}$   
 $\therefore$  Total losses =  $4.1 + 4.26 + 4.46 = 12.82 \text{ kW}$   
 $I_1 = I_2'^2 + I_0 = 83.67 + 2.53 = 86.20 \text{ Amp}$   
 $I_0 = V_{Ph} / \sqrt{R_0^2 + X_0^2}$   
 $= 1154.7 / \sqrt{450^2 + 77^2}$   
 $= 2.529 \text{ Amp}$



$$\eta = \{246.40 / (246.40 + 12.82)\} \times 100$$

$$= 95.05\%$$

**Q.37** A 2300-V, three phase, 60 Hz, star-connected cylindrical synchronous motor has a synchronous reactance of  $11 \Omega$  per phase. When it delivers 200 hp, the efficiency is found to be 90% exclusive of field loss, and the power-angle is 15 electrical degrees as measured by a stroboscope. Neglect ohmic resistance and determine:

(a) the induced excitation per phase.

(b) the line current  $\bar{I}_a$

(c) the power factor

**(8+4+4)**

**Ans:**

Given : 2300V , 3 phase, 60Hz, Synch. Motor

$$X_S = 11 \Omega / \text{ph} , \text{ Star connected, } V_{\text{Ph}} = 2300 / \sqrt{3} \text{ V}$$

$$P_0 = 200 \text{ hp} = 200 \times 735.5 = 147.1 \text{ kW}$$

$$\eta = 90\%$$

$$\therefore P_i = P_0 / 0.9 = 163.44 \text{ kW}$$

$$\text{Power angle } \alpha = 15^\circ \text{ (electrical)}$$

Find: induced excitation / ph ( $E_g$ ) = ?

$$\text{Line Current } I_a = ?$$

$$\text{Power Factor } \cos \Phi = ?$$

$$(i) \quad P_i = \frac{3 \times E_g / \text{ph} \times V_{\text{Ph}}}{X_S} \times \sin \alpha$$

$$\therefore E_g / \text{ph} = P_i X_S / 3 \times V_{\text{Ph}} \times \sin \alpha$$

$$= 163.44 \times 10^3 \times 11 / 3 \times 1327.9 \times \sin 15^\circ$$

$$E_g / \text{ph} = 1743.68 \text{ volts (Due to over excitation)}$$

Given  $Z_S = 0 + j 11$  and  $R=0$

$$E_R = (V_{\text{Ph}} - E_g \cos \alpha) + j 1743.68 \sin 15^\circ$$

$$= -356.36 + j 451.296$$

$$\therefore I_a = E_R / Z_S = (-356.36 + j 451.30) / (0 + j 11)$$

$$= 41.02 + j 32.42$$

$$I_a = 52.28 \angle 38.32^\circ$$

(ii) Line current = 52.28 Amp

(iii) & p.f  $\cos \Phi = \cos 38.32^\circ = 0.78$

**Q.38** When a 250-V, 50 hp, 1000 rpm d.c shunt motor is used to supply rated output power to a constant torque load, it draws an armature current of 160A. The armature circuit has a resistance of  $0.04 \Omega$  and the rotational losses are equal to 2 KW. An external resistance of  $0.5 \Omega$  is inserted in series with the armature winding. For this condition compute

- (i) the speed
- (ii) the developed power
- (iii) the efficiency assuming that the field loss is 1.6 K.W (8+4+4)

**Ans:**

Given  $V_L = 250 \text{ V}$   $P_0 = 50 \text{ hp} = 50 \times 735.5 = 36.78 \text{ kW}$   
 $N_1 = 1000 \text{ rpm}$   $I_a = 160 \text{ amp.}$  ,  $R_a = 0.04 \Omega$  ,  $R = 0.5 \Omega$  ,  
 Rotational losses = 2 kw ; Field losses = 1.6 kW

Find : speed after series resistance R in armature circuit  $N_2 = ?$   
 Power developed ( $P_m$ ) = ?  
 Efficiency ( $\eta$ ) = ?

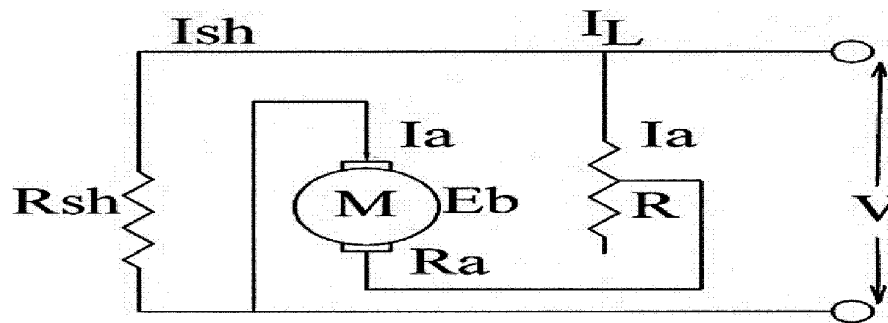

(i)  $E_{b1} = N_1(\Phi P Z / 60 A)$

And  $V = E_{b1} + I_a R_a$

$$E_{b1} = 250 - 160 \times 0.04 = 243.60 \text{ volts}$$

Now  $E_{b2}$  when  $R = 0.5$  connected in series with armature

$$\therefore E_{b2} = 250 - 160 \times (0.04 + 0.5)$$

$$= 163.6 \text{ volts}$$

Now  $E_{b1} / E_{b2} = N_1 / N_2$  (when  $\Phi_1 = \Phi_2$ )

$$N_2 = N_1 \times E_{b2} / E_{b1} = 1000 \times 163.6 / 243.6 = \mathbf{672 \text{ rpm}}$$

- (ii) Now Input power developed in armature =  $E_{b2} I_a$   
 $= 163.6 \times 160 = \mathbf{26.18 \text{ kW}}$

Total losses = Armature 'Cu' Losses + Field loss + Rotational losses

$$= (I_a^2 R_a' / 1000) + 1.6 \text{ kW} + 2.0 \text{ kW}$$

$$= (160^2 \times 0.54 / 1000) + 1.6 + 2.0$$

$$= \mathbf{17.42 \text{ kW}}$$

(iii) Efficiency =  $(P_i - \text{losses} / P_{in}) \times 100$

$$= (26.18 - 17.42 / 26.18) \times 100$$

$$= \mathbf{33.46\%}$$

**Q.39** The following data were obtained on a 20KVA, 50Hz, 2000/200V distribution transformer

Open Circuit Test (on L.V. side): 200V, 4A, 120W

Short Circuit Test (on H.V. side): 60V, 10A, 300W

Draw the approximate equivalent circuit of the transformer referred to H.V. Side. (8)

**Ans:**

Given : 20 kVA, 50Hz, 2000/ 200V

O.C Test :  $V_0 = 200 \text{ V}$  ;  $I_0 = 4 \text{ A}$  ;  $W_0 = 120 \text{ W}$

S.C Test :  $V_{SC} = 60 \text{ V}$  ;  $I_{SC} = 10 \text{ A}$  ;  $W_{SC} = 300 \text{ W}$

Primary equivalent secondary induced voltage

$$E_2' = E_2 / K$$

$$V_2' = V_2 / K$$

$$\& I_2' = KI_2$$

From O.C Test:

$$V_0 I_0 \cos \Phi_0 = W_0$$

$$\therefore \cos \Phi_0 = W_0 / V_0 I_0 = 120 / 200 \times 4 = \mathbf{0.15}$$

$$\therefore \sin \Phi_0 = \mathbf{0.988}$$

$$\text{Now } I_w = I_0 \cos \Phi_0 = 4 \times 0.15 = 0.60 \text{ Amp.}$$

$$I_u = I_0 \sin \Phi_0 = 4 \times 0.988 = 3.95 \text{ amp.}$$

$$R_0 = V_0 / I_w = 200 / 0.6 = \mathbf{333.33 \Omega}$$

$$X_0 = V_0 / I_u = 200 / 3.95 = \mathbf{50.63 \Omega}$$

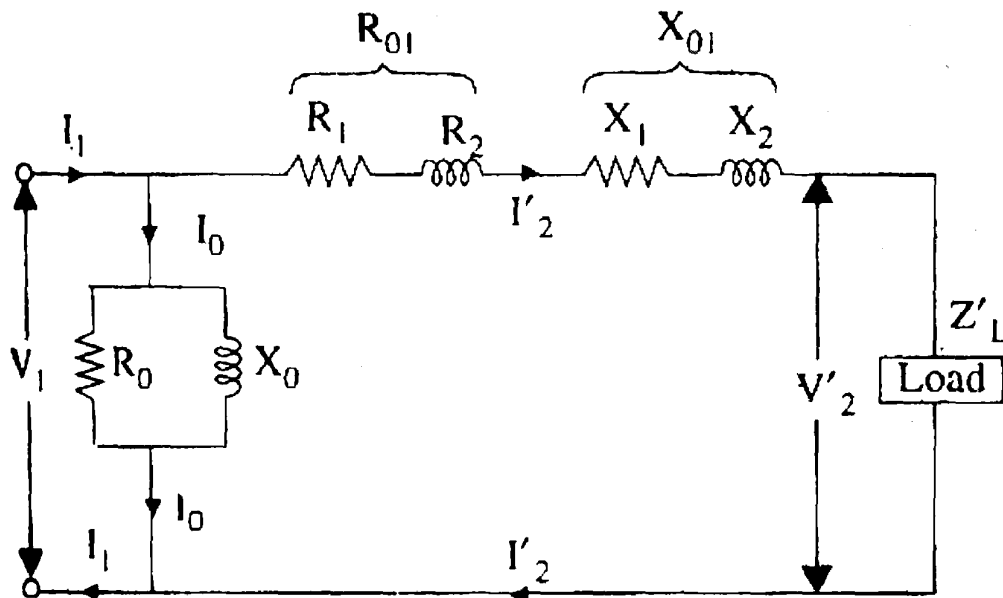

From S.C test:

$$Z_0 = V_{SC} / I_{SC} = 60 / 10 = 6\Omega$$

$$\text{and } K = 200 / 2000 = 1/10 = 0.1$$

$$Z_{01} = Z_{02} / k^2 = 60 / (1/10)^2 = 600\Omega$$

$$\text{Now } I_{SC}^2 R_{02} = W_{SC}$$

$$\therefore R_{02} = W_{SC} / I_{SC}^2 = 300 / 100 = 3\Omega$$

$$R_{01} = R_{02} / k^2 = 3 / (1/10)^2 = 300\Omega$$

$$X_{01} = \sqrt{(Z_{01}^2 - R_{01}^2)} = \sqrt{(600^2 - 300^2)}$$

$$X_{01} = 519.62\Omega$$

- Q.40** The efficiency of a 3-phase 400V, star connected synchronous motor is 95% and it takes 24A at full load and unity power factor. What will be the induced e.m.f. and total mechanical power developed at full load and 0.9 power factor leading? The synchronous impedance per phase is  $(0.2 + j2)\Omega$ . (9)

**Ans:**

Given :  $3\Phi$ , 400V star connected synchronous motor

Output = 95% of input

$$V_{Ph} = 400/\sqrt{3}$$

$$\text{at } p.f = 1 ; I_a = 24 \text{ amp. ; } V = V_{Ph} = 230.94 \text{ volt}$$

$$Z_S = (0.2 + j2) \Omega = 2 \angle 84.29^\circ \Omega$$

Find :  $E_b$  at 0.9 p.f leading

Mechanical power developed ?

$$\begin{aligned}\cos \Phi &= 0.9 \\ \therefore \Phi &= 25.84^\circ \\ E_R = IZ_S &= 24(0.2 + j2) \text{ volts} \\ &= (4.8 + j48) \text{ volts} = 48.23 \angle 84.29^\circ \\ \theta &= 84.29^\circ\end{aligned}$$

Now at leading p.f

$$\begin{aligned}E_{b/ph} &= V + I_a Z_S \cos \{180 - (\theta + \Phi)\} + j I_a Z_S \sin \{180 - (\theta - \Phi)\} \\ \therefore E_{b/ph} &= 231 + 24 \times 2 \cos \{180 - (84.29 + 25.84)\} + j 24 \times 2 \sin \{180 - (84.29 - 25.84)\} \\ &= 231 + 48 \cos (69.87) + j 48 \times 0.938 \\ &= 231 + 16512 + j45 \\ E_{b/ph} &= 247.5 + j 45 \\ E_{b/ph} &= 251.55 \angle 10.3\end{aligned}$$

$$\begin{aligned}\text{Synchronous motor input power} &= \sqrt{3} V_L I_L \cos \Phi \\ &= \sqrt{3} V I_a \cos \Phi = \sqrt{3} \times 400 \times 24 \times 0.9 \\ &= 14,964.92 \text{ watt}\end{aligned}$$

$$\begin{aligned}\text{total copper losses} &= 3 I^2 R_a \\ &= 3 \times (24)^2 \times 0.2 = 3 \times 576 \times 0.2 \\ &= 345.6 \text{ watt}\end{aligned}$$

$$\begin{aligned}\therefore \text{Mechanical output developed} &= \text{Input} - \text{losses} \\ &= 14964.92 - 345.6 \\ &= 14619.32 \text{ watt}\end{aligned}$$

- Q.41** A 200V shunt motor with a constant main field drives a load, the torque of which varies at square of the speed, when running at 600 r.p.m., it takes 30A. Find the speed at which it will run and the current it will draw, if a 20Ω resistor is connected in series with armature. Neglect motor losses. (9)

**Ans:**

Given:  $V = 200\text{v}$ , shunt motor

$$N_1 = 600 \text{ rpm}$$

$$I_1 = 30\text{A} = I_{a1}$$

Find :  $N_2$  &  $I_2$  ; when  $R = 20\Omega$  added with  $R_a$  in series

$$E_{b1} = V - I_a R_a \text{ (losses are negligible , } \therefore I_a R_a = 0)$$

$$E_{b1} = V = 200\text{v} \quad (I_a R_a = 0)$$

$$\begin{aligned}T_1 &= 9.55 E_{b1} I_1 / N_1 = 9.55 \times 200 \times 30 / 600 \\ &= 573\text{Nm}\end{aligned}$$

$$T \propto N^2$$

$$\therefore T_1 / T_2 = N_1^2 / N_2^2$$

$$\therefore N_2^2 / T_2 = N_1^2 / T_1 = 600^2 / 573$$

$$\text{Or } N_2 = 600 \sqrt{T_2 / 573}$$

(1)

$$\text{and } N_1 / N_2 = E_{b1} / E_{b2} \cdot \Phi_2 / \Phi_1 \quad (\Phi_2 = \Phi_1 = \text{constt})$$

$$\therefore N_1 / N_2 = E_{b1} / E_{b2}$$

$$\text{or } N_2 = N_1 (E_{b2} / E_{b1})$$

$$N_2 = 600 (E_{b2} / 200)$$

$$N_2 = 3E_{b2} \quad (2)$$

And

$$E_{b2} = 200 - 20I_2 \quad (3)$$

$$(E_{b2} = V - I_a R_a)$$

$$E_{b2} = N_2 / 3 \text{ from eqn. no. (2) put in eqn. no (3)}$$

$$\therefore N_2 = 600 - 60I_2 \quad (4)$$

$$T_1 / T_2 = N_1^2 / N_2^2 = I_1 / I_2$$

$$\therefore 600^2 / N_2^2 = 30 / I_2$$

$$30 / I_2 = 600^2 / (600 - 60I_2)^2 \quad (N_2 = 600 - 60I_2)$$

$$30 / I_2 = 600 \times 600 / 60 \times 60 (10 - I_2)^2$$

$$10I_2 = 3(100 + I_2^2 - 20 I_2)$$

$$10I_2 = 300 + 3I_2^2 - 60 I_2$$

$$\therefore 3I_2^2 - 70 I_2 + 300 = 0$$

$$I_2 = \frac{70 \pm \sqrt{4900 - 4 \times 3 \times 300}}{6} = 5.66 \text{ or } 17.66$$

$$\underline{I_2} = \mathbf{5.66 \text{ amp}}$$

$$\therefore N_2 = 600 - 60I_2$$

$$= 600 - 60 \times 5.66 = 260.55 \text{ rpm}$$

$$\underline{N_2} = \mathbf{260 \text{ rpm}}$$

$I_2 = 5.66 \text{ amp}$ ,  $17.66 \text{ amp}$  is not possible for  $N_2$

**Q.42** A 3-phase induction motor has a starting torque of 100% and a maximum torque of 200% of full load torque. Find

(i) Slip at maximum torque.

(ii) Full load slip.

(iii) Neglect the stator impedance (8)

**Ans:** Given :  $(T_{st} / T_f) = 1$  &  $(T_{max} / T_f) = 2$

$$\therefore (T_{st} / T_{max}) = 1/2 = 0.5$$

$$\text{let } a = R_2 / X_2$$

$$\therefore (T_{st} / T_{max}) = 2a / (1+a^2) = 0.5/1$$

$$2a / (1+a^2) = 1/2$$

$$4a = 1 + a^2$$

$$a^2 - 4a + 1 = 0$$

$$a = \frac{4 \pm \sqrt{16 - 4 \times 1 \times 1}}{2}$$

$$a = \frac{4 \pm \sqrt{12}}{2}$$

$$a = 3.73 \quad \text{or} \quad 0.2679$$

**a = slip at max torque = 0.2679**

$$\text{Now, } T_f / T_{\max} = 1/2 = 2aS_f / a^2 + S_f^2 \quad (S_f = \text{full load slip})$$

$$2 \times 0.2679 \times S_f / \{(0.2679)^2 + S_f^2\} = 1/2$$

$$0.5358 S_f / \{(0.0717) + S_f^2\} = 1/2$$

$$\therefore 1.071 \times S_f = (0.0717) + S_f^2$$

$$S_f^2 + 1.071S_f + 0.0717 = 0$$

$$S_f = 0.9995 \quad \text{or} \quad 0.07145$$

**\(\therefore\) full load slip = 0.07145**

**Q.43** A universal motor (a.c. operated) has a 2-pole armature with 960 conductors. At a certain load the motor speed is 5000 r.p.m. and the armature current is 4.6A. The armature terminal voltage and input are respectively 100 V and 300 W. Compute the following, assuming an armature resistance of 3.5Ω.

(i) Effective armature reactance

(ii) Max. value of useful flux per pole.

**(8)**

**Ans:** Given:  $P=2$  ;  $Z=960$  ;  $N_1=5000$  rpm ;  $I_{a1}=4.6$  amp

$$V_a = 100\text{v} = I_{a1}R_a$$

$$P_i = 300 \text{ watt}$$

$$R_a = 3.5 \text{ ohms}$$

$$\text{Find } X_a = ?$$

$$\Phi_m / \text{pole} = ?$$

$$P_i = VI \cos \Phi$$

$$\therefore \cos \Phi = P_i / VI = 300 / 100 \times 4.6 = 300 / 460$$

$$= 0.652$$

$$\text{Now } E_{\text{bac}} = V \cos \Phi - I_a R_a = 100 \times 0.652 - 4.6 \times 3.5$$

$$= 49.1 \text{ volts}$$

$$\text{and } V^2 = (E_{\text{bac}} + I_a R_a)^2 + (I_a X_a)^2$$

$$100^2 = (49.1 + 4.6 \times 3.5)^2 + (4.6 X_a)^2$$

$$(4.6 X_a)^2 = 100^2 - (49.1 + 16.1)^2 = 10000 - (65.2)^2$$

$$= 10,000 - 4251 = 5748.96$$

$$21.16 X_a^2 = 5748.96$$

$$\therefore X_a = \sqrt{5748.96 / 21.16}$$

$$= \mathbf{16.48 \Omega}$$

$$\text{and } E_{\text{bdc}} = V - I_a R_a = 100 - 4.6 \times 3.5 = \mathbf{83.9 V}$$

$$\text{and } E_{\text{bdc}} = N \Phi_m P Z / 60 A$$

$$83.9 = 5000 \Phi_m \times 2 \times 960 / 60 \times 2$$

$$\Phi_m = 83.9 / 8.0 \times 10^4 = \mathbf{1.048 \times 10^{-3} \text{ wb}}$$

$$(i) \therefore \text{effective armature reactance} = 16.48 \Omega$$

$$(ii) \text{Max. flux per pole} = 1.048 \times 10^{-3}$$

- Q.44** Using normal  $\Pi$  method, find the sending end voltage and voltage regulation of a 250Km, 3 phase, 50Hz transmission line delivering 25MVA at 0.8 lagging p.f. to a balanced load to 132KV. The line conductors are spaced equilaterally 3m apart. The conductor resistance is  $0.11\Omega/\text{Km}$  and its effective diameter is 1.6 cm. Neglect leakage. (8)

**Ans:** Given:

$$3\Phi, \quad 50\text{Hz}, \quad d = 250\text{km}$$

$$P_0 = 25\text{mVA}, \quad \cos \Phi = 0.8 \text{ (lagging)}, \quad V_R = 132 \text{ KV}$$

$$V_{R/\text{ph}} = 132000 / \sqrt{3} \text{ V}$$

$$\text{Spacing between conductors} = 3\text{m}$$

$$R = 0.11 \Omega/\text{km}$$

$$\text{Dia (D)} = 1.6 \times 10^{-2} \text{ m}$$

$$\text{Find : } V_s = ? \text{ and } \% \text{ regulation} = ?$$

$$I_{\text{ph}} = P_0 / V_{R/\text{ph}}$$

$$I = 25 \times 10^6 / 132 \times 1000 = 25000/132$$

$$\text{Line loss} = 3 I^2 R = 3 \times (25000 / 132)^2 \times 0.11 \times 250$$

$$\text{Resistance / phase} = 0.11 \times 250 = 27.5 \Omega$$

$$V_{S/\text{ph}} = V_{R/\text{ph}} + IZ ; \quad (Z = R/\text{Phase})$$



$$\begin{aligned}
 &= (132000/\sqrt{3}) + (25000/132) \times 27.5 \\
 &= 76210.236 + 5208.333 \\
 &= 81418.569 \\
 &= \mathbf{81.42 \text{ KV}}
 \end{aligned}$$

$$\begin{aligned}
 \% \text{ Regulation} &= (V_S - V_R/V_S) \times 100 \\
 &= ((81.42 - 76.21)/81.42) \times 100 \\
 &= \mathbf{6.39 \%}
 \end{aligned}$$

**Q.45** A 3-phase transformer bank consisting of a three one-phase transformer is used to step-down the voltage of a 3-phase, 6600V transmission line. If the primary line current is 10A, calculate the secondary line voltage, secondary line current and output kVA for the following connections:

(i) Y/ $\Delta$  and (ii)  $\Delta$ /Y. The turns ratio is 12. Neglect losses. (8)

**Ans:** (i) Y/ $\Delta$

Given turn ratio = 12

$V_1 = 6600\text{V}$ ,  $I_1 = 10\text{A}$ ,

$V_2 = ?$ ,  $I_2 = ?$

o/p = kVA

$I_{PP}$  = Phase current in primary winding

$I_{LP}$  = Line current in primary winding

For Y :  $V_p = V_L/\sqrt{3}$ ,  $I_p = I_L$

$\Delta$  :  $V_p = V_L$ ,  $I_p = I_L/\sqrt{3}$

$V_{PP}/V_{PS} = N_1/N_2$

$V_{LP}/V_{LS} = \sqrt{3} V_{PP}/V_{PS} = \sqrt{3} N_1/N_2 = 12\sqrt{3}$

$V_{LS} = V_{LP}/12\sqrt{3} = 6600/12\sqrt{3}$

$V_{LS} = 315.33 \text{ Volts}$

$I_{PP}/I_{PS} = N_2/N_1$

$I_{LP}/I_{LS} = I_{PP}/\sqrt{3} \times 1/I_{PS} = (1/\sqrt{3}) \times (N_2/N_1)$

$I_{LS} = (1/\sqrt{3}) \times (N_1/N_2) \times I_{LP} = 12\sqrt{3} \times 10 \text{ Amp.}$   
 $= 120\sqrt{3} \text{ Amp.}$

o/p kVA =  $V_{LS} \times I_{LS}$   
 $= \frac{6600 \times 12\sqrt{3} \times 10}{12\sqrt{3}}$

o/p = **66kVA**

(ii)  $\Delta/Y$ 

$$\begin{aligned} \text{For } Y : V_p &= V_L/\sqrt{3}, \quad I_p = I_L \\ \Delta : V_p &= V_L, \quad I_p = I_L/\sqrt{3} \end{aligned}$$

$$\begin{aligned} V_{PP}/V_{PS} &= N_1/N_2 \\ V_{LP}/V_{LS} &= V_{PP}/\sqrt{3} V_{PS} = 1/\sqrt{3} \times N_1/N_2 = 12/\sqrt{3} \\ V_{LS} &= \sqrt{3} V_{LP}/12 = \sqrt{3} \times 6600/12 \\ V_{LS} &= 550\sqrt{3} \text{ Volts} \end{aligned}$$

$$\begin{aligned} I_{PP}/I_{PS} &= N_2/N_1 \\ I_{LP}/I_{LS} &= \sqrt{3} I_{PP}/I_{PS} = \sqrt{3} N_2/N_1 = \sqrt{3}/12 \end{aligned}$$

$$I_{LS} = 12/\sqrt{3} \times 10 = 40\sqrt{3} \text{ Amp.}$$

$$\begin{aligned} \text{o/p kVA} &= V_{LS} \times I_{LS} \\ &= \frac{\sqrt{3} \times 6600 \times 12 \times 10}{12 \times \sqrt{3}} \end{aligned}$$

$$\text{o/p} = 66 \text{ kVA}$$

- Q.46** A 3300V, delta-connected motor has a synchronous reactance per phase (delta) of  $18\Omega$ . It operates at a leading power factor of 0.707 when drawing 800kW from the mains. Calculate its excitation emf. (8)

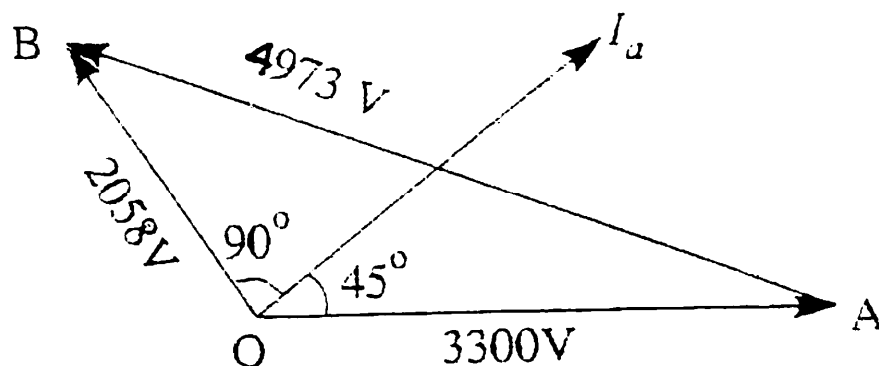

$$\sqrt{3} V_L I_a \cos \Phi = \sqrt{3} \times 3300 \times I_a \times 0.707 = 80,000$$

$$\therefore \text{Line current} = 198 \text{ A, Phase current } I_a = 198/\sqrt{3} = 114.3 \text{ A}$$

$$Z_S = 18\Omega : I_a Z_S = 114.3 \times 18 = 2058 \text{ V}$$

$$\Phi = \cos^{-1} 0.707 ; \Phi = 45^\circ ; \theta = 90^\circ$$

$$\cos (\theta + \Phi) = \cos 135^\circ = -\cos 45^\circ = -0.707$$

From Fig, we find

$$E_b^2 = 3000^2 + 2058^2 - 2 \times 3000 \times 2058 \times -0.707$$

$$E_b = 4973 \text{ V}$$

- Q.47** The magnetization characteristic of 4-pole DC series motor may be taken as proportional to current over a part of the working range, on this basis the flux per pole is 4.5 mWb/A. The load requires a gross torque proportional to the square of the speed equal to 30 Nm at 1000 rev/min. The armature is wave-wound and has 492 conductors. Determine the speed at the which the motor will run and current it will draw when connected to a 220V supply, the total resistance of the motor being 2.0  $\Omega$ .

(7)

**Ans:**

$$\begin{aligned} E_a &= (\phi N Z / 60) \times (P/A) \\ &= \frac{(4.5 \times 10^{-3} \times I_a) \times N \times 492}{60} \quad (4/2) \\ &= 0.0738 N I_a \end{aligned} \quad (1)$$

The torque developed :

$$\begin{aligned} T &= \phi I_a Z (P/A) = (1/2\pi) (4.5 \times 10^{-3} I_a) \times 492 \quad (4/2) \\ &= 0.705 I_a^2 \end{aligned} \quad (2)$$

$$\text{Further } E_a = V - I_a (R_a + R_{sc}) = 220 - 2 I_a \quad (3)$$

Substituting equation (1) in (3)

$$\begin{aligned} 0.0738 N I_a &= 220 - 2 I_a \\ I_a &= 220 / 2 + 0.0738 N \end{aligned} \quad (4)$$

Substituting the expression for  $I_a$  in equation (2)

$$T = 0.705 (220/2 + 0.0738 N)^2$$

$$\text{Given, } T_L = K_L N^2$$

From the given data  $K_L$  can be calculated as

$$K_L = 30/1000^2 = 3 \times 10^{-5} \text{ Nm/rpm}$$

Under steady operation condition  $T_L = T$

$$\text{Or } 3 \times 10^{-5} N^2 = 0.705(200 / 2 + 0.0738 N)^2$$

$$N = 662.6 \text{ rpm}$$

Substituting for N in equation (4)

$$I_a = 220 / (2 + 0.0738 \times 663.2) = 4.32 \text{ Amp.}$$

- Q.48** A 150kW, 3000V, 50Hz, 6-pole star-connected induction motor has a star-connected slip-ring rotor with a transformation ratio of 3.6 (stator/rotor). The rotor resistance is  $0.1\Omega$ /phase and its per phase leakage inductance is 3.61 mH. The stator impedance may be neglected. Find (i) the starting current and torque on rated voltage with short-circuited slip-rings, and (ii) the necessary external resistance to reduce the rated voltage starting current to 30A and the corresponding starting torque.

**Ans:**  $X_2 = 2\pi \times 50 \times 3.61 \times 10^{-3} = 1.13\Omega$   
 $K = 1/3.6$   
 $\Rightarrow R_2' = R_2 / K^2 = 3.6^2 \times 0.1 = 1.3\Omega$   
 $X_2' = 3.6^2 \times 1.13 = 14.7\Omega$

(i)  $I_{ST} = V / \sqrt{(R_2')^2 + (X_2')^2} = (3000/\sqrt{3}) / \sqrt{(1.3)^2 + (14.7)^2}$   
 $= \mathbf{117.4\text{ A}}$

$N_s = 120 \times 50 / 6 = 1000\text{ rpm} = 50/3\text{ rps}$

$T_{ST} = (3/2\pi N_s) \{V^2 / (R_2')^2 + (X_2')^2\}$   
 $= (3 / 2\pi \times 50/3) \times \{ (3000/\sqrt{3})^2 / (1.3)^2 + (14.7)^2 \}$   
 $= \mathbf{513\text{ Nm}}$

(ii) Let the new resistance be R for  $I_{ST} = 30\text{A}$   
 $I_{ST} = V / \sqrt{(R)^2 + (X_2')^2} = 3000\sqrt{3} / \sqrt{(R)^2 + (14.7)^2}$   
 $R^2 = (3000 / \sqrt{3} / 30)^2 - (14.7)^2$   
 $= (100/\sqrt{3})^2 - 14.7^2$   
 $R = 55.83\Omega$

Necessary external resistance =  $R - R_2' = 55.83 - 1.3 = \mathbf{54.53\Omega}$

Corresponding starting torque

$T_{ST1} = 3 / 2\pi (50/3) \times \{ (3000 / \sqrt{3})^2 \times R / (R)^2 + (14.7)^2 \}$   
 $= 3 / 2\pi (50/3) \times \{ 30 \times 30 \times 55.83 / 1 \}$   
 $T_{ST} = \mathbf{1438.89\text{ Nm}}$

- Q.49** An ac operated universal motor has a 2-pole armature with 960 conductors. At a certain load the motor speed is 5000 rpm and the armature current is 4.6A; the armature terminal voltage and input are respectively 100 V and 300 W. Calculate the following quantities assuming an armature resistance of  $3.5\Omega$ .

- (i) Effective armature reactance  
(ii) Max. value of useful flux/pole. (8)

**Ans:**

The operating conditions in terms of voltage and current of the armature circuit are shown in the Fig :

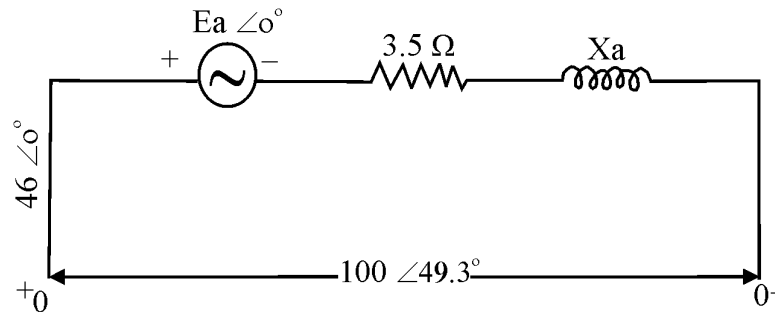

$$100 \times 4.6 \cos \phi = 330 \text{ W}$$

Or  $\phi = 49.3^\circ$  (lagging because of the reactive nature of the circuit)

(a) From the circuit the following can be written

$$\frac{100 \times \angle 49.3^\circ - E_a \angle 0^\circ}{3.5 \times j X_a} = 4.6 \angle 0^\circ$$

$E_a$  is in phase with  $I_a$

$$\text{Or } 65.2 + j75.8 - E_a = 16.1 + j 4.6 X_a$$

Equating real & imaginary parts

$$E_a = 65.2 - 16.1 = 49.1 \text{ V}$$

$$X_a = 75.8 / 4.6 = \mathbf{16.5 \Omega}$$

$$(b) E_a = 1/\sqrt{2} \{(\phi N Z / 60) \times (P/A)\}$$

$$\phi = \frac{\sqrt{2} \times 49.1 \times 60}{5000 \times 960}$$

$$= \mathbf{0.868 \text{ mwb}}$$

**Q.50** Define voltage regulation of a single phase transformer. The primary and secondary winding of a 40kVA, 6600/250V, single phase transformer have resistance of 10 ohm and 0.02 ohm respectively. The total leakage reactance is 35 ohm as referred to the primary winding. Find full load regulation at a pf of 0.8 lagging. (8)

**Ans:** Primary Voltage  $V_1 = 6600 \text{ V}$

Secondary Voltage  $V_2 = 250 \text{ V}$

Transformation ratio  $k = V_2 / V_1 = 250/6600 = 0.03788$

Equivalent resistance of transformer referred to secondary,

$$\begin{aligned} R_{o2} &= k^2 R_1 + R_2 = (0.03788)^2 \times 10 + 0.02 \\ &= 0.03435 \Omega \end{aligned}$$

equivalent leakage reactance of transformer referred to secondary,

$$X_{O2} = K^2 X_{O1} = (0.03788)^2 \times 35 = 0.05022\Omega$$

$$\begin{aligned} \text{Secondary rated current, } I_2 &= \text{Rated kVA} \times 1000 / V_2 \\ &= 40 \times 1000 / 250 = 160 \text{ A} \end{aligned}$$

$$\text{Power factor } \cos \Phi = 0.8 \text{ and } \sin \Phi = \sqrt{1-0.8^2} = 0.6$$

$$\begin{aligned} \text{Full load regulation} &= \frac{I_2 R_{O2} \cos \Phi + I_2 X_{O2} \sin \Phi}{E_b} \times 100 \\ &= \frac{160 \times 0.3435 \times 0.8 + 160 \times 0.05022 \times 0.6}{250} \times 100 \\ &= \mathbf{3.687 \%} \end{aligned}$$

- Q.51** A star connected synchronous motor at 187 kVA, 3- $\phi$ , 2300V, 47A, 50Hz, 187.5 rpm has an effective resistance of 1.5 ohm and a synchronous reactance of 20 ohm per phase. Determine internal power developed by the motor when it is operating at rated current and 0.8 power factor leading. (6)

**Ans:** Line voltage,  $V_L = 2300\text{V}$   
 Line Current  $I_L = 47 \text{ A}$   
 Power Factor  $\cos \Phi = 0.8$   
 Power supplied to the motor,  $P = \sqrt{3} V_L I_L \cos \Phi$   
 $= \sqrt{3} \times 2300 \times 47 \times 0.8 = 1,49,780\text{Watts}$   
 $= 149.78 \text{ kW}$   
 Total Copper loss  $= 3 I^2 R$   
 $= 3 \times (47)^2 \times 1.5 = 9,940 \text{ watts or } 9.94 \text{ kW}$   
 Internal power developed  $= P - 3 I^2 R$   
 $= 149.78 - 9.94 = \mathbf{139.84 \text{ kW}}$

- Q.52** A 220V dc shunt motor takes 22A at rated voltage and run at speed of 1,000 rpm. Its field resistance is 100 ohm and armature resistance is 0.1 ohm. Compute the value of additional resistance required in armature circuit to reduce the speed to 800 rpm when (i) load torque is proportional to speed and (ii) when load torque varies as the square of the speed. (10)

**Ans:** In normal Condition  
 Line current,  $I_{L1} = 22\text{A}$   
 Shunt field current,  $I_{sh} = V / R_{sh} = 220 / 100 = 2.2\text{A}$   
 Armature current,  $I_{a1} = I_{L1} - I_{sh} = 22 - 2.2 = 19.8\text{A}$   
 Back emf,  $E_{b1} = V - I_{a1} R_a = 220 - 19.8 \times 0.1 = 218.02 \text{ V}$   
 Speed  $N_1 = 1000 \text{ rpm}$

Let the additional resistance required in armature current be of  $R$  ohms to reduce the speed to 800 rpm when the load torque is proportional to speed.

$$T_2 = T_1 N_2 / N_1 = T_1 800 / 1000 = 0.8 T_1$$

$$\text{Or } I_{a2} \Phi_2 = 0.8 I_{a1} \Phi_1$$

$$\text{Or } I_{a2} = 0.8 \times 19.8 = 15.84 \text{ A}$$

$$\begin{aligned} E_b &= V - I_{a2} (R + R_a) = 220 - 15.84 (R + 0.1) \\ &= 218.416 - 15.84 R \end{aligned}$$

$$\text{Since } E_{b2} / E_{b1} = N_2 / N_1$$

$$(218.416 - 15.84R) / 218.02 = 800 / 1000$$

$$\mathbf{R = 2.778 \Omega}$$

(ii) Let the additional resistance required in the armature current be of  $R'$  ohms to reduce the speed to 800 rpm when no load torque varies as the square of the speed.

$$T_3 = T_1 \times (N_2 / N_1)^2 = T_1 \times (800 / 1000)^2 = 0.64 T_1$$

$$\text{Or } I_{a3} \Phi_3 = 0.64 I_{a1} \Phi_1$$

$$I_{a3} = 0.64 \times 19.8 = 12.672 \text{ A}$$

$$\begin{aligned} E_{b3} &= V - I_{a3} (R' + R_a) = 220 - 12.672 (R' + 0.1) \\ &= 218.7328 - 12.672 R' \end{aligned}$$

$$\text{Since } E_{b3} / E_{b1} = N_3 / N_1$$

$$(218.7328 - 12.672 R') / 218.02 = 800 / 1000$$

$$\mathbf{R' = 3.497 \Omega}$$

- Q.53** A 120V, 60 Hz,  $\frac{1}{4}$  hp universal motor runs at 2000rpm and takes 0.6 Amp when connected to a 120V dc source. Determine speed, torque and power factor of the motor, when it is connected to a 120V, 60 Hz supply, and is loaded to take 0.6 Amp(rms). The resistance and inductance measured at terminals of the machine are 20 ohm and 0.25H respectively. (8)

**Ans:** When connected to DC supply

Supply Voltage,  $V = 120V$

Current drawn,  $I = 0.6 \text{ A}$

$$\begin{aligned}\text{Back e.m.f, } E_b &= V - IR \\ &= 120 - 0.6 \times 20 = 108\text{V}\end{aligned}$$

$$\text{Speed, } N_{dc} = 2000 \text{ rpm}$$

When connected to AC supply

$$\text{Supply Voltage, } V = 120\text{V}$$

$$\text{Current drawn, } I = 0.6 \text{ A}$$

$$\text{Resistance drop } = IR = 0.6 \times 20 = 12\text{V}$$

$$\begin{aligned}\text{Counter emf, } E &= \sqrt{[V^2 - (IX)^2]} - IR \\ &= \sqrt{[(120)^2 - (47.12)^2]} - 12 \\ &= 98.36\text{V}\end{aligned}$$

$$\begin{aligned}\text{Speed } N_{ac} &= \frac{N_{dc} \times E}{E_b} \\ &= \frac{2000 \times 98.36}{108} \\ &= 1,821.5 \text{ rpm}\end{aligned}$$

$$\begin{aligned}\text{Power factor, } \cos \Phi &= (E + IR)/V = (98.36 + 12)/120 \\ &= 0.92 \text{ lagging}\end{aligned}$$

$$\begin{aligned}\text{Torque developed, } T &= E \times I / (2\pi N/60) \\ &= 98.36 \times 0.6 \times 60 / (2\pi \times 1821.5) = 0.31 \text{ Nm}\end{aligned}$$

- Q.54** A single phase generator supplies an inductive load of 4800 KW at a power factor of 0.6 lagging by means of an overhead line which is 25 km long. The line resistance and inductance are respectively  $0.02 \Omega$  and  $0.58 \text{ mH}$  per km. The voltage at the receiving end is to be kept constant at  $10.5 \text{ KV}$ . Find the sending end voltage and the voltage regulation of the line. (8)

**Ans** Given :

$$1\Phi \text{ generator, inductive load, kVAR} = 4800 \text{ kW}$$

$$\cos \Phi = 0.6; \text{ distance} = 25 \text{ km}$$

$$R = 0.02\Omega/\text{km} \quad L = 0.58 \text{ mH}/\text{km} \quad V_R = 10.5 \text{ kV}$$

$$\text{Find } V_S = ? ; \% \text{ regulation} = ?$$

$$\text{Drop in line } \Delta V = V_S - V_R$$

$$V_S - V_R = RP + XQ / V_R$$



Where R = total line resistance

P = Active Power transfer

Q = Reactive power transfer

$V_S$  = sending end voltage

$V_R$  = receiving end voltage

$$P = kW = \text{Reactive power} / \tan\Phi$$

$$= 4800 / 1.333 = 3600 \text{ kW}$$

$$Q = 4800 \text{ kW}$$

$$V_S = \frac{0.02 \times 25 \times 3600 + 4800 \times 2 \times 3.14 \times 50 \times 0.58 \times 10^{-3} \times 25}{10500} + V_R$$

$$= 19.225 + V_R$$

$$= 19.225 + 10500$$

$$= 10.52 \text{ kV}$$

$$\% \text{ regulation} = (V_S - V_R / V_S) \times 100$$

$$= 0.19 \%$$

Code: AE10  
PART - III

Subject: ELECTRICAL ENGINEERING

**DESCRIPTIVES**

**Q.1** Draw and explain the phasor diagram of a transformer on load at a lagging power factor.

(7)

**Ans: (D)**

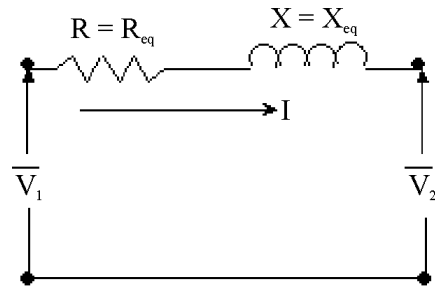

**Fig. AA1**

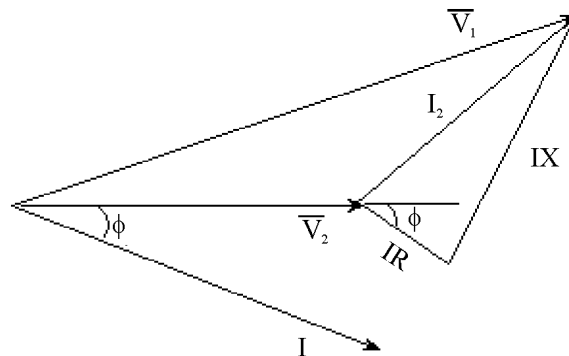

**Fig. AA2**

Fig AA2 shows the phase diagram of a transformer on a load at lagging power factor and corresponds to the equivalent circuit of transformer (Fig. AA1) in which all quantities are referred to the primary. Thus  $\bar{V}_2$  is the secondary terminal voltage referred to the primary [where over bar implies a phasor].

$$R = R_{eq} = R_1 + R_2' = R_1 + R_2 \left( \frac{N_1}{N_2} \right)^2$$

Where  $R_1$  and  $R_2$  are primary and secondary resistances,  $N_1$  and  $N_2$  are primary and secondary number of turns and  $X_{l1}$  and  $X_{l2}$  are leakage reactances of primary and secondary windings.

Also

$$X = X_{eq} = X_{l_1} + X'_{l_2} = X_{l_1} + \left(\frac{N_1}{N_2}\right)^2 X_{l_2}$$

The voltage  $\bar{V}_1$  which is applied to the primary can be written as

$$\bar{V}_1 = \bar{V}_2 + \bar{I} (R + jX)$$

**Q.2** Explain with proper phasor diagrams the operation of a 3 phase synchronous machine with normal excitation at the following conditions:

- (i) The machine is floating on the supply bus. (7)  
 (ii) The machine is working as a synchronous motor at no load. (7)

**Ans:**

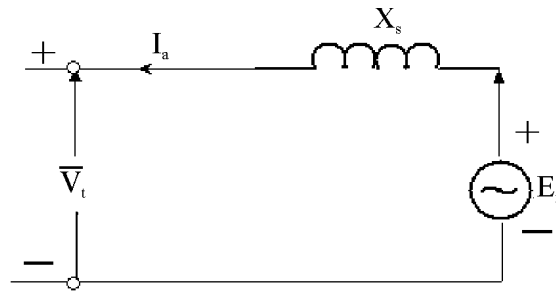

(a) Generating Mode

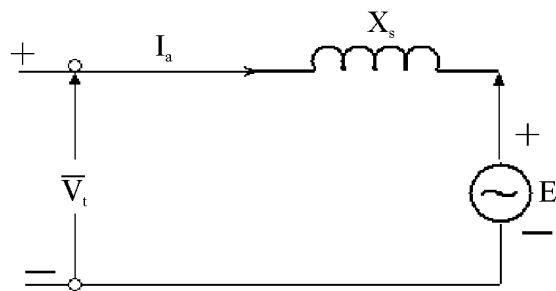

(b) Motor Mode

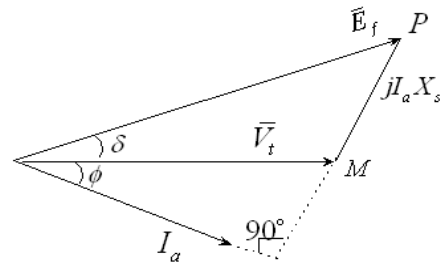

(c)

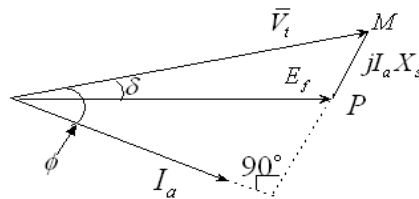

(d)

Fig.B1 Synchronous machine operations  
(Generating mode and Motoring mode)

Fig B1 shows the circuit diagrams and phasor diagrams of a synchronous machine at generating mode [Fig B1(a)& (c)] and motoring mode [Fig B1(b)&(d)] . The machine is assumed to be connected to an infinite busbar of voltage  $V_t$  and its resistance is taken to be zero. It is seen from [Fig B1(c)] that in the generating mode, the excitation emf  $E_f$  leads  $V_t$  by an angle  $\delta$  ; on the other hand in the motoring mode  $E_f$  lags  $V_t$ .

It can be inferred from the above that, when the machine is floating, it is working neither as a generator nor as a motor and  $I_a$  will be equal to zero.  $\bar{E}_f$  and  $\bar{V}_t$  will be equal and have the same phase [Fig. B2]

$$\longrightarrow \bar{V}_t = \bar{E}_f$$

Fig. B2

When the machine is working as a synchronous motor at no load, the figures B1 (b) and (d) will hold good, but with a very small value for the current  $I_a$ ; correspondingly the angles  $\delta$  and  $\phi$  will be small. The reason for this is, that at no load the machine will take that much power which is the sum of friction and windage losses. [Fig B3] and is small.  $jI_a X_s$  will also be small.

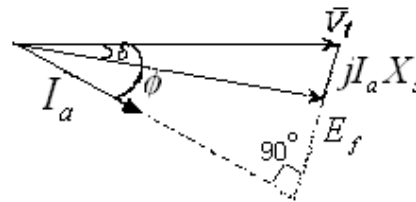
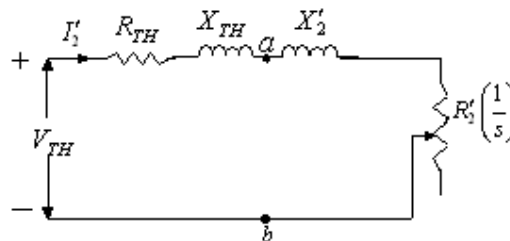

Fig. B3

- Q.3** Draw the torque speed characteristics of a 3 phase induction motor and clearly indicate the effect of change in rotor resistance. (7)

**Ans:** The Thevenin equivalent of an induction motor circuit model is given in Figure D1



Thevenin equivalent of induction motor circuit model

Fig. D1

The torque developed can be expressed as

$$T = \frac{3V_{Th}^2 \left( \frac{R_2'}{s} \right)}{\omega_s \left[ \left( R_{TH} + \frac{R_2'}{s} \right)^2 + (X_{TH} + X_2')^2 \right]} \quad \text{---(A)}$$

The torque speed characteristics [or,  $T - \omega_s$  characteristics] can be obtained from Equation (A); for different values of rotor resistance are shown in Fig.D2

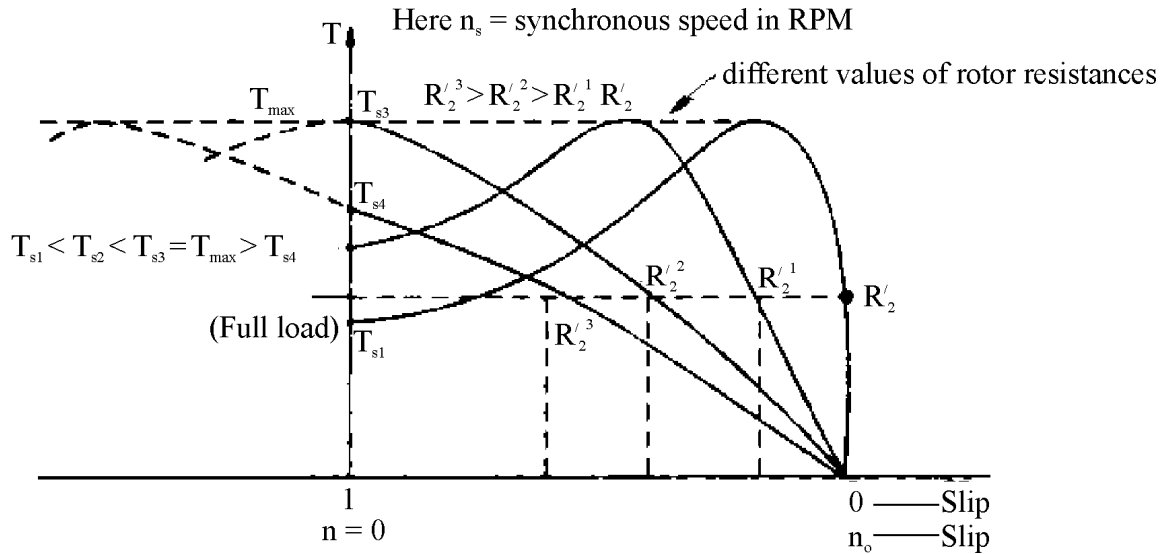

**Fig. D2** Torque-slip characteristics of induction motor with increasing values of rotor resistance

Effects of change in rotor resistance are:

- (1) The starting torque is affected: it increases with increase in  $R_2$ , goes to a maximum of  $T_{max}$  and then decreases with further increase in  $R_2$ .
- (2)  $T_{max}$ , remains the same but the slip at which it occurs is changed with  $R_2$ .

**Q.4** For a small and sensitive servo mechanism give four reasons why a.c. servo motors are generally preferred to d.c. servo motor. (7)

**Ans:** A dc servomotor is often employed in a control system where an appreciable amount of shaft power is required. These servomotors have separately excited fields. They are either armature controlled with fixed field or field controlled with fixed armature current. For example the dc servomotor [Fig.E1] used in instrument employs a fixed permanent magnetic field, and the control signal as applied to the armature terminals.

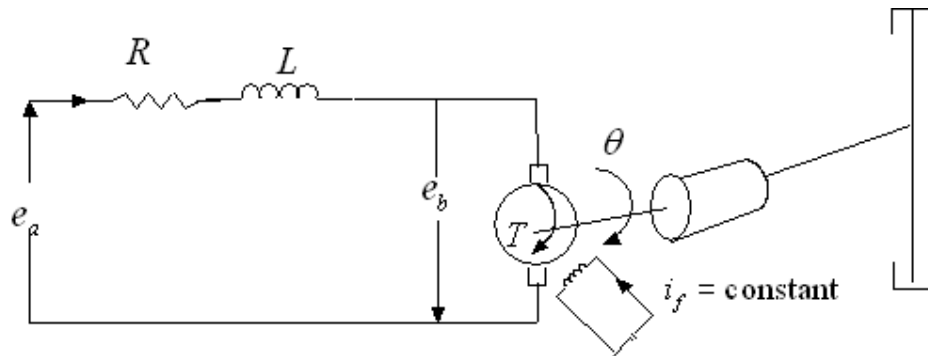

Fig. E3

The two phase ac servomotor [Fig E2] on the other hand is ideally suited for low power control applications. The two phases are called control phase (phase a) and reference phase (phase m), the latter being excited at a fixed magnitude of synchronous a.c. voltage, both voltages being taken from the same source. The control phase voltage is shifted in phase by  $90^\circ$  from the reference phase voltage by means of phase-shifting networks. The motor torque gets reversed by phase reversal of the control phase voltage.

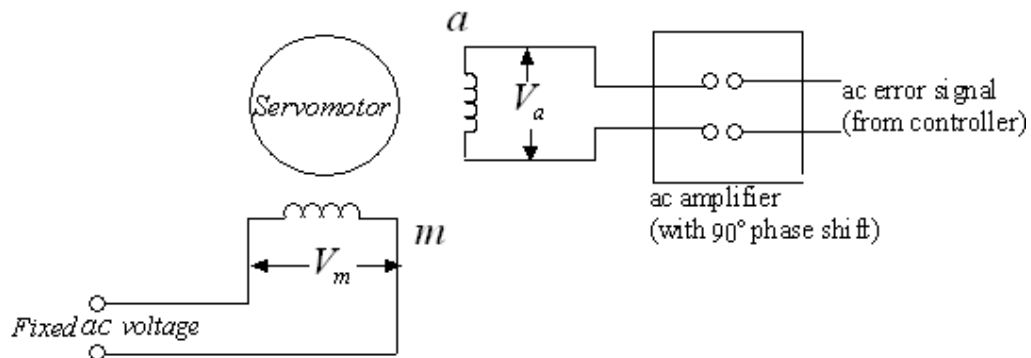

Fig. E2 Control scheme for 2-phase servomotor

The ac servomotor offers several advantages over its d.c. counterpart:

- (i) a drift-free ac amplifier is used in the control circuitry.
- (ii) it has low rotor inertia and hence faster response.
- (iii) it has rugged, maintenance-free rotor construction
- (iv) it has no brushes that contact the commutator segments. The rotor can withstand a higher temperature as it does not involve any insulation.

**Q.5** What are different types of resistance welding? (3)

**Ans:** In resistance welding a heavy current is passed through the joint to be welded and the heat caused by the resistance of the joint is sufficient to cause fusion of the metal. Three types of resistance welding exist and they are as follows:

- (i) **Butt Welding:** This method is used for welding of rods, wires or small pipes; the two ends are pressed together mechanically to form a butt joint as shown in Fig G1

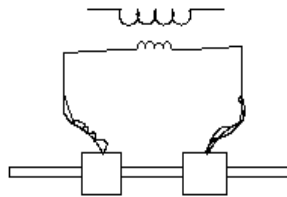

Fig. G1 Butt welding

- (ii) **Spot Welding:** For jointing two or even three sheets of metal by means of an overlapping joint, as shown in Fig G2, The sheets are held between two electrodes and current is passed between these electrodes, causing fusion at a single spot.

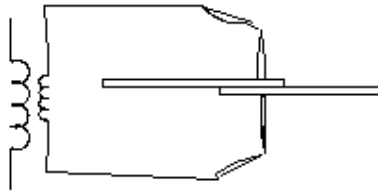

Fig. G2 Spot welding

- (iii) **Seam Welding :** Where a continuous joint is required between two overlapping sheets of metal, as in constructing a tank, the two electrodes used in spot welding are replaced by two wheels between which the work travels. However it is not advisable to make a continuous weld, as there is then a tendency for the heat gradually to build up as the welding progresses and cause burning and warping.

**Q.6** What are different welding controls used in resistance welding? (4)

**Ans:** The three different controls commonly in use are as follows:

- (i) **Mechanical Control for Constant – time equipment:** A cam- operated switch connected in the primary circuit of the welding transformer and driven from the welding machine provides a simple device.



- (ii) **Valve-operated Control for Constant-time: Devices:** To overcome the difficulties encountered in the case of mechanically operated gears at high speeds, various valve-operated devices have been developed, for example, the mercury-vapour valve.
- (iii) **Current and energy- actuated control:** With this control, current is allowed to flow until a predetermined amount of energy has been supplied to the weld.

**Q.7** Explain the principle of high frequency induction heating. What factors control the depth of penetration of heat? Give the industrial application of this mode of heating. (7)

**Ans:** Induction heating processes make use of currents induced by electromagnetic action in the material to be heated. Sufficient currents that cause effective heating can be produced only in materials of low resistivity, however it is necessary to use a magnetic field of very high frequency.

For coreless induction furnaces, the depth of penetration( $t$ ) is given by the formula

$$t = \frac{1}{2\pi} \sqrt{\frac{\rho \cdot 10^9}{\mu f}}$$

where  $\rho$  = specific resistance of the molten charge [ $200 \times 10^{-6}$  ohm/cm for steel]

$f$  = frequency(Hz)

and  $\mu$  = permeability (this factor has a value of 1.0 for molten steel)

For normal supply frequency, with the power factor in the range 0.8-0.85 and in sizes upto about 1 tonne, the vertical core-type furnace is widely used in foundries for melting and refining brass and other non-ferrous metals. On the other hand the coreless induction furnace is used for the production of very high grade alloy steels; in small sizes it is widely used for work on alloys and precious metals.

**Q.8** What is the fundamental difference between thermal and nuclear power plants? (3)

**Ans:** In a thermal power plant heat is released in combustion of coal; this heat is used in a boiler to raise steam.

Here the coal is conveyed to a mill and crushed into a fine powder, this being termed as pulverization. The pulverized coal is blown into the boiler where it mixes with the supply of air for combustion. Heat is transferred to steam pipes located in the top region of the boiler, these being initially fed with hot water from the boiler feed pump; the hot water then gets converted to steam at high temperature and pressure. This steam is fed to the steam turbines which are the prime movers for electric generators.

In a nuclear power plant binding energy of a nucleus is released by fission, which means breaking the nucleus into smaller fragments. Here one gram of the nucleus of uranium is isotope  $^{235}\text{U}$  releases energy at the rate of 1 MW/per day whereas 2.6 tons of coal produces the same amount of power in a conventional thermal power plant. The process of fission is carried out in a nuclear reactor. Thus the nuclear reactor is a very efficient source of energy because a small amount of fissile material produces a large amount of energy.

**Q.9** List the advantages of nuclear power plants over conventional thermal power plants. (4)

**Ans:**

- (i) A nuclear power plant is completely free of air pollution.
- (ii) It requires very little fuel in terms of volume and weight and therefore poses no transportation problems. The nuclear power plant may be sited, independently of nuclear fuel supplies, close to load centres. However safety considerations require that these plants be normally located away from populated areas.
- (iii) When one pound of pure uranium is completely fissioned it will create as much heat as the burning of 1500 tons of coal.
- (iv) Whereas the stock of coal is limited and the supply of coal will go down in the coming decades, it is the nuclear energy that is promising. Nuclear power plants will therefore be important sources of electrical power in future.

**Q.10** Discuss briefly the solid state circuits used for the stator voltage control of induction motor drives. (7)

**Ans :** Fig H1 shows the block diagram for a scheme of stator voltage control. Here the ratio  $V/f$  is kept constants, with the frequency being varied by means of an inverter. This in turn will help in maintaining the field flux constant. The rectifier and inverter are rigged by means of the thyristors or GTOs or MOSFETs. Because of its high cost, this type of control is justified only for drives wherein rugged, maintenance-free characteristics of the induction motor are essential.

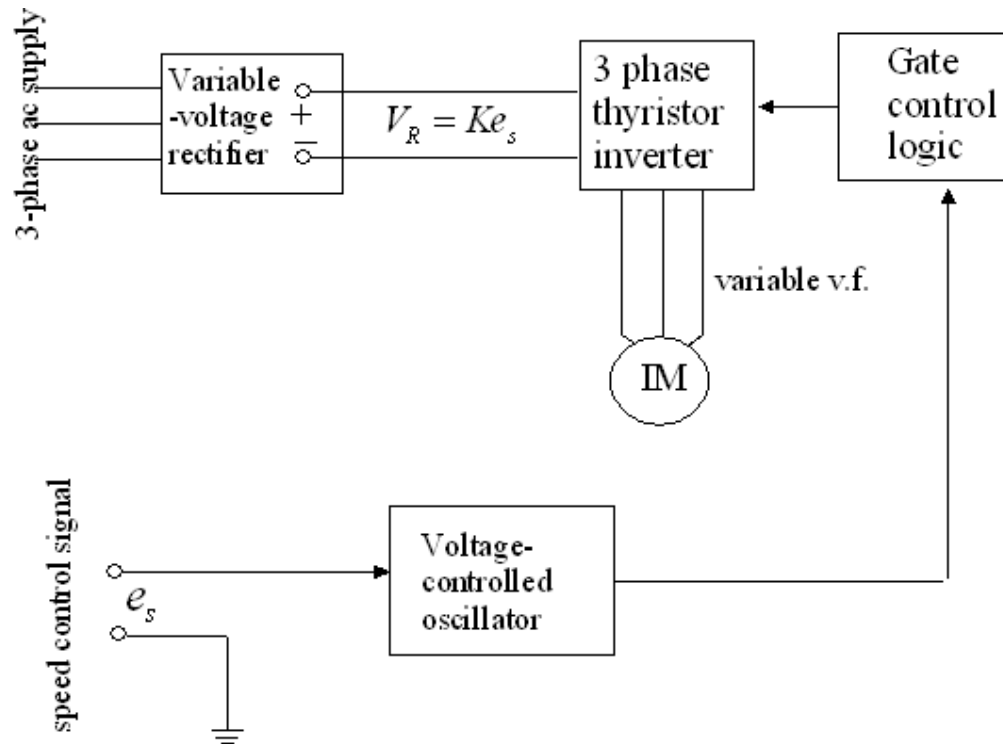

Fig. H1 Frequency-control of induction motor speed;  
 $\text{speed} \propto e_s$ , flux/pole constant

**Q.11** Differentiate between feeder, distributor and service main. (3)

**Ans:** Fig K1 shows a typical distribution system consisting of various kinds of substations and feeders, finally ending up with consumer's service lines. The sequence, as shown in the figure, is as follows:

Firstly sub-transmission lines at 66KV emanate from a transmission substation. A distribution transformer at the 66 KV substation steps down this voltage from 66KV to 11KV, that is, the primary feeder voltage. At the distribution substation transformer this (11KV) is further stepped down to 415 V which is the voltage of the consumer's services lines.

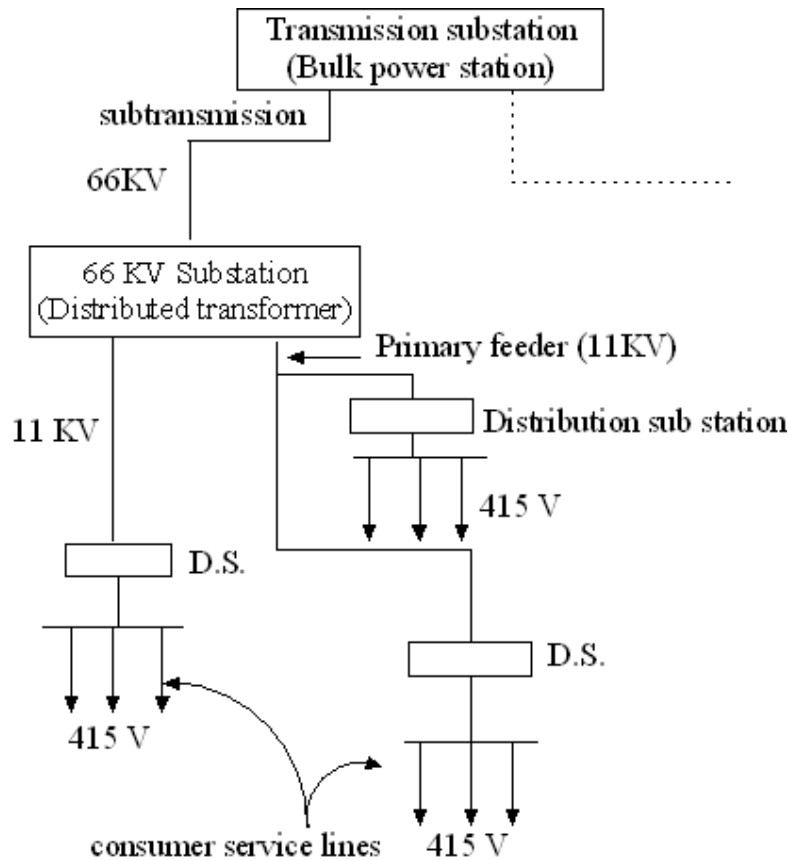

Fig. K1

**Q.12** What are the advantages of high voltage transmission? Give its limitations also. (4)

**Ans:** High voltage transmission is subdivided into HVAC and HVDC transmission systems.

(i) **HVAC transmission:** Advantages of HVAC transmission are as follows:

As the voltage is increased, the current carried by the conductors decreases. The  $i^2R$  losses correspondingly get reduced. However the cost of transmission towers, transformers, switches and circuit breakers rapidly increases with increase in voltage, in the upper ranges of a.c. transmission voltages.

(ii) **HVDC transmission:**

**Advantages** They (HVDC lines) are economical for bulk power transmission. The voltage regulation problem is much less in DC since only  $IR$  drop is involved. There

is easy reversibility and controllability of power flow through a DC link. Also there is considerable insulation economy.

**Limitations:** The systems are costly since installation of complicated converters and DC switchgear is expensive. The converters require considerable reactive power. Lack of HVDC circuit breakers hampers network operation. Moreover there is nothing like DC transformer; voltage transformation has to be provided on the a.c. sides of the system.

**Q.13** Discuss the working principle of a direction over-current relay. (7)

**Ans : Overcurrent relay:** This relay operates when current through it (sample of power system current) satisfies the condition

$$Q = K_1 |I|^2 - K_4 > 0$$

$$\text{or } |I| > \sqrt{\frac{K_4}{K_1}} = |I_p|$$

where  $|I_p|$  is said to be the pickup value of the relay. Such a relay is an over current relay and would operate in the shortest possible time (depending upon the type of hardware employed), and is called instantaneous overcurrent relay.

Thus if:

$$|I| > |I_p| \text{ the relay trips the circuit breaker}$$

and

$$\text{if } |I| < |I_p| \text{ the relay blocks or does not trip the circuit breaker.}$$

The directional feature can be incorporated for the above o/c relay by means of an induction cup type of structure (Fig L1) one of the coils being current excited and the other, voltage excited.

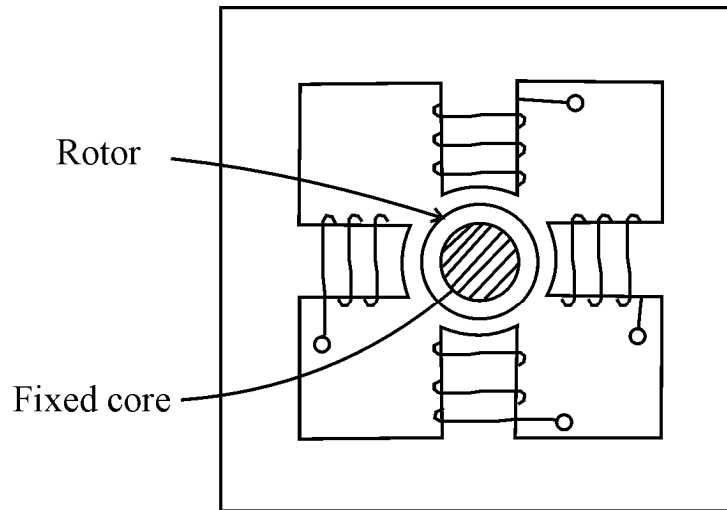

Fig. L1 Induction cup structure

The phasor diagram of a directional relay is shown in Fig. L2.  $I_v$ , the voltage coil current lags the voltage applied by an angle depending upon the coil impedance. Since the fluxes are proportional to the coil currents, and have the same angle separation as coil currents, the relay torque can be expressed as

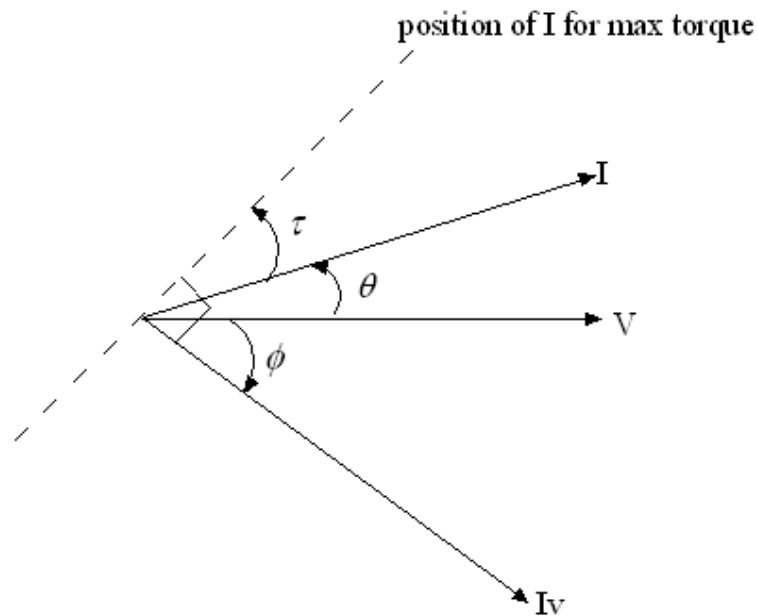

Fig. L2 Phasor diagram of directional relay

$$T = K_3 |V| |I| \sin(\theta - \phi) \quad (\text{A})$$

where  $\phi$  = phase angle of voltage coil current  $I_v$

and  $\theta$  = angle by which the current applied to the relay leads its voltage

The proportionality

$$F_{(av)} \propto |\phi_1| |\phi_2| \quad (\text{B})$$

where  $\phi_1$  and  $\phi_2$  can be treated as fluxes from the current and voltage coils and  $F_{(AV)}$ , net (average) force or an induction type of disc.

Taking the leading angle as positive and defining  $\tau$  (a relay parameter) as the value of  $\theta$ , when the relay develops maximum torque, then

$$\tau - \phi = 90^\circ$$

Substitution of this relation in Equn (A) gives

$$T = K_3 |V| |I| \cos(\theta - \tau)$$

which indeed is the directional characteristic

- Q.14** Explain the working of nickel cadmium cells with its merits and demerits over lead acid cell. (7)

**Ans: Nickel- Cadmium cells:** In a Nickel-Cadmium cell the positive plates are made of nickel hydroxide enclosed in finely perforated steel tubes or pockets, the electrical resistance being reduced by the addition of flakes of pure nickel or graphite. These tubes or pockets are assembled in nickelled-steel plates. The active material in this cell is Cadmium mixed with a little iron, the latter being used to prevent caking of the active material and hence an impairment to porosity.

The electrolyte is a solution of potassium hydroxide (KOH) having a relative density of about 1.15 to 1.20 depending upon the type of cell and the condition of service. The electrolyte does not undergo any chemical change; hence the quantity of electrolyte can be reduced to the minimum value necessitated by adequate clearance between the plates. The plates are separated by insulating rods and assembled in sheet-steel containers, the latter being mounted in non-metallic crates so as to insulate the cells from one another.

#### Chemical reaction

<i>Positive</i>	<i>Negative</i>	<i>Positive</i>	<i>Negative</i>
<i>plate</i>	<i>plate</i>	<i>plate</i>	<i>plate</i>

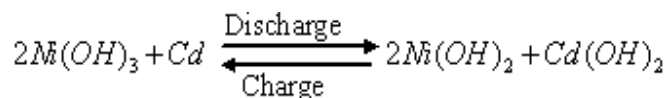

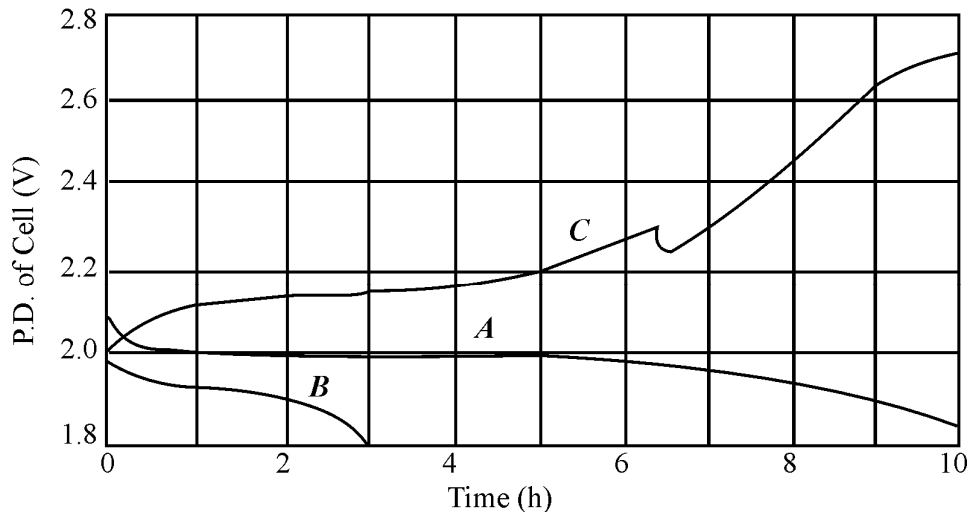

**Fig. M1 Characteristics of an alkaline cell**

The curve A in Fig M1 represents the terminal voltage of a nickel-cadmium cell during discharge at the 10-hour rate, while curve B shows the variation for a 3-hour rate.

The curve C represents the variation of the terminal voltage when the cell is charged at a rate 1.5 times the 10-hour discharge rate.

The advantages of the nickel-cadmium cell are:

- a) Its mechanical construction enables it to withstand considerable vibration.
- b) It is free from 'sulphating' or any similar trouble and can therefore be left in any state of charge without damage.

The disadvantages are:

- a) Its cost is higher than that of the lead-acid cell
- b) Its average discharge p.d. is about 1.2V as compared to 2V for the lead-acid cell, so that for a given voltage, the number of alkaline cells is about 67 percent larger than that of lead-acid cells.

**Q.15** Discuss methods of laying underground cables. (7)

**Ans: Methods of laying underground cables**

Underground cables are generally required in urban areas where there is a high density of population. The highest load density and the most restrictive limitations on feeder layout occur simultaneously in the central cores of major cities. Load densities are usually in the range of 60 to 100 MW per square mile.



Some problems associated with underground cable systems are as follows:

urban area are densely populated with/pedestrian walk ways, as well as water, sewer, storm drain, phone and other utility systems in addition to electrical. So there is limited room. The electrical utility must stake its claim to the routes and space allocated to it with its own duct banks.

Secondly, duct banks are needed to protect underground cable from the constant dig-ins of other utilities, stress from settling, and heat and moisture in this environment. Thirdly, digging into the street in an urban area for new additions or repairs is very expensive. Traffic control and other requirements add to cost and also digging around all the other utilities. Thus electric utilities have no choice but to use duct banks and cable vaults to create their own “cable tunnel system“ under the streets in dense urban areas.

Finally branching of underground cable providing for “T” or “X” connections of paths, while possible, is not as simple or as inexpensive as in overhead lines.

Summarizing, the underground urban area systems have the following characteristics

- Layout is restricted to street grid
- Loads are large and invariably three phase
- Fixed cost is very high
- The cost of capacity shortfall is extremely high

**Q.16** Write short notes on any **TWO** of the following :-

- Switched reluctance motors.
- Parallel operation of transformers.
- Selsyns.

(7 x 2 = 14)

**Ans:**

**(i) Switched reluctance motors:** A synchronous motor with salient poles but no field winding is known as the reluctance motor. It is used for low power, constant speed applications where special arrangements for d.c. excitation would be cumbersome.

The principle of this motor is that the stator produces a rotating field in space and the rotor is noncylindrical such that the reluctance of the magnetic path offered by the rotor to the rotating field is a function of the space angle. Here the rotor has the tendency to align itself in the minimum reluctance position with respect to the synchronously rotating flux of the forward field. The motor is made self starting by the induction principle by providing short-circuited copper bars in the projecting parts of the rotor.

In the single phase reluctance motor the rotating field can be produced by one of the phase-splitting methods. The salient pole structure is given to the rotor by removing some of the teeth of an induction motor rotor as shown in Fig M2. The remaining teeth carry short-circuited copper bars to provide the starting induction torque. After starting, the rotor reaches near synchronous speed by induction action and is pulled into synchronism during the positive half-cycle of the sinusoidally varying synchronous torque.

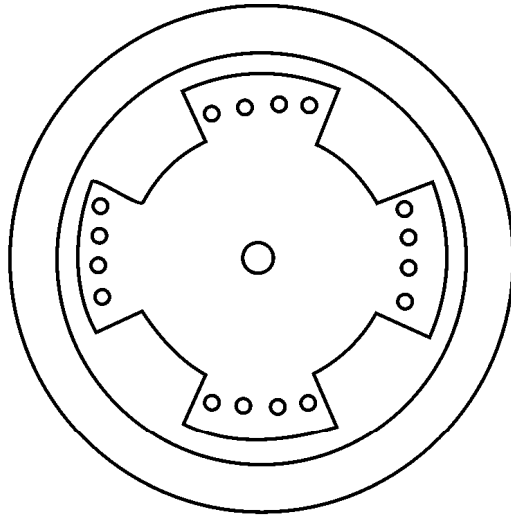

Fig. M2 Constructional features of 4-pole reluctance motor

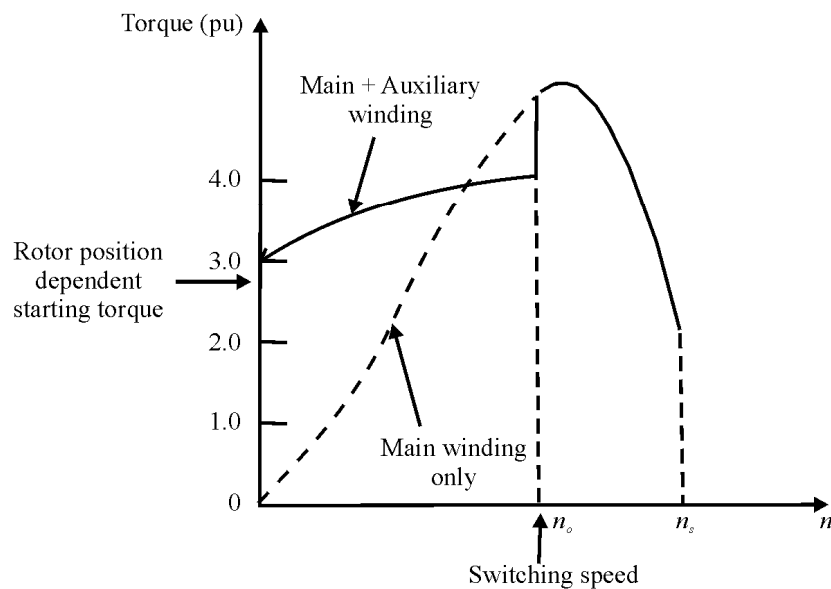

Fig. M3 Reluctance motor torque-speed characteristic

This would only be possible if the rotor has low inertia and the load conditions are light. The torque speed characteristic of a typical reluctance motor with induction start is given in Fig M3. Here the starting torque is highly dependent upon the rotor position because of the projecting nature of the rotor. This phenomenon is known as “**cogging**”. For satisfactory synchronous motor performance the frame size to be used must be much larger than that for normal single- phase induction motor. This accounts for the high value of starting torque shown in Fig M3.

(ii) **Parallel operation of transformers:** when the load exceeds the capacity of an existing transformer, it may be economical to install another one in parallel rather than replacing it with a single larger unit. Also for reliability two smaller units in parallel are preferred. The cost of maintaining a spare is also less with two units in parallel.

For satisfactory parallel operation of transformers the following conditions have to be fulfilled:

(i) They must be connected with proper polarities; this is to ensure that the net voltage around the local loop is zero. A wrong polarity connection results in a dead short circuit.

(ii) 3 phase transformers must have zero relative phase displacement on the secondary sides and must be connected with proper phase sequence. Only the transformers of the same group can be paralleled. For example Y/Y and Y/ $\Delta$  transformers cannot be paralleled as their secondary voltages will have a phase difference of  $30^0$

(iii) The transformers must have the same voltage ratio to avoid no-load circulating current, when the transformers are in parallel on both primary and secondary sides.

(iv) There should exist only a limited disparity in the per unit impedances (on their own bases) of the transformers. The currents carried by the two transformers are proportional to their ratings if their p.u. impedances on their own ratings are equal.

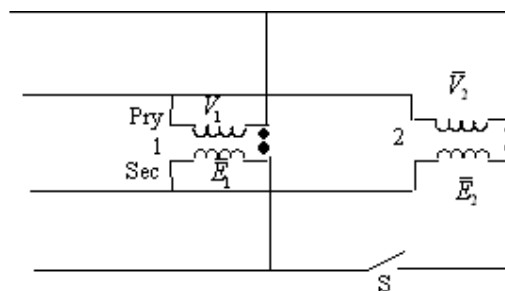

FigN1 Parallel transformers on no-load

Fig N1 shows two transformers paralleled on both sides with proper polarities but on no load. The primary voltages  $V_1$  and  $V_2$  are equal. If the voltage ratios of the two

transformers are not identical, the secondary voltages  $E_1$  and  $E_2$  though in phase will not be equal in magnitude. The difference ( $E_1 - E_2$ ) will appear across the switch S. When the secondaries are paralleled by closing the switch, a circulating current appears even though the secondaries are not supplying any load. The circulating current will depend upon the total leakage impedance of the two transformers and also the difference in their voltage ratios. Only a small difference in the voltage ratios will be tolerated.

**Division of load between transformers in parallel. Equal voltage ratios** When the transformers have equal ratios  $E_1 = E_2$  in Fig N1, the equivalent current of the two transformers would then be as shown in Fig N2 on the assumption that the exciting current can be neglected in comparison to the load current.

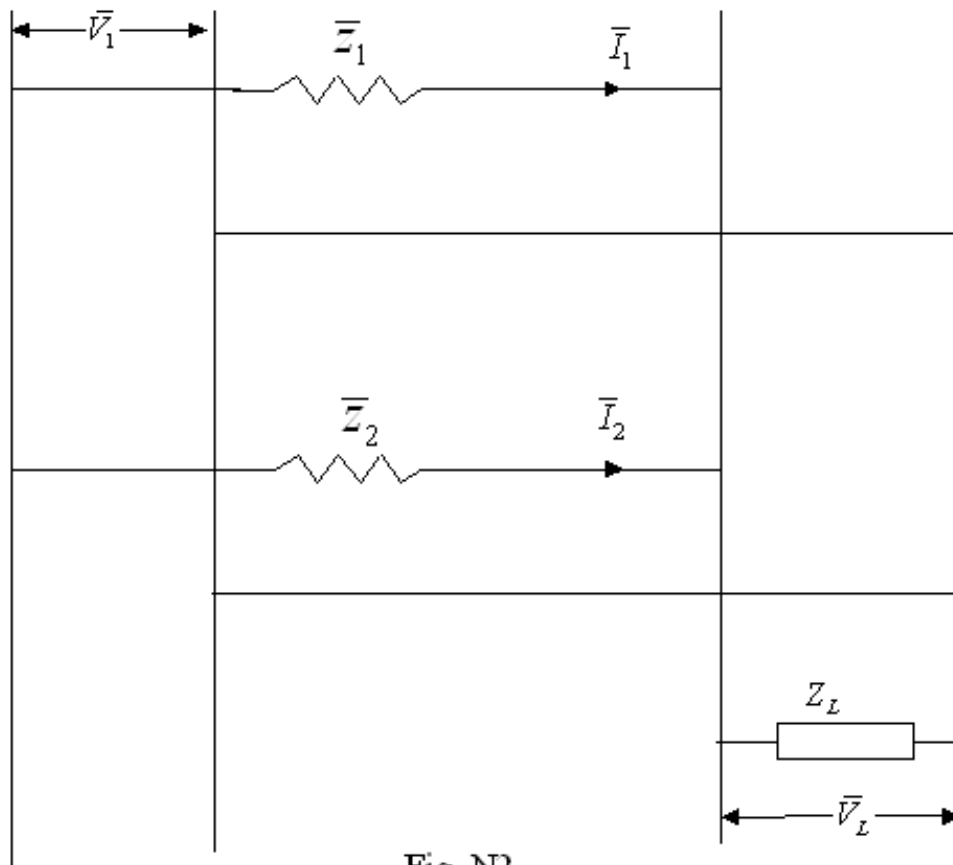

Fig. N2

It follows from the sinusoidal steady-state circuit analysis that

$$\bar{I}_1 = \frac{\bar{Z}_2}{\bar{Z}_1 + \bar{Z}_2} I_L \quad (1)$$

$$\text{and } \bar{I}_2 = \frac{\bar{Z}_1}{\bar{Z}_1 + \bar{Z}_2} I_L \quad (2)$$

$$\text{also } \bar{I}_1 + \bar{I}_2 = I_L$$

Taking  $\bar{V}_L$  as the reference phasor and defining complex power as  $\bar{V} * \bar{I}$ , the multiplication of  $\bar{V}_L$  on both sides of equations (1) and (2) give

$$\bar{S}_1 = \frac{\bar{Z}_2}{\bar{Z}_1 + \bar{Z}_2} S_L$$

$$\bar{S}_2 = \frac{\bar{Z}_1}{\bar{Z}_1 + \bar{Z}_2} S_L$$

$$\text{where } \bar{S}_1 = \bar{V}_L * \bar{I}_1$$

$$\bar{S}_2 = \bar{V}_L * \bar{I}_2$$

$$\bar{S}_L = \bar{V}_L * I_L$$

The above equations  $\bar{S}_1$ ,  $\bar{S}_2$  and  $\bar{S}_L$  are phasor relationships giving loadings in the magnitude and phase angle.

**(iii) Selsyns:** Selsyns or synchros are control system components which are used for transmission of small torques or motions electrically. They can be categorized into three kinds:

- for transmission of small torques electrically, as synchro-transmitter-receiver pair (Fig P2)
- for indicating the difference in positions, as generator – transformer combination (Fig P3)
- as differential selsyns (Fig P4)

In the synchro-transmitter-receiver pair (Fig P2) which is a single phase selsyn, the stator has three windings like the polyphase induction motor. The rotor is similar to the rotor of a small alternator and of one winding. Fig P1 shows the cross-section of a single phase selsyn.

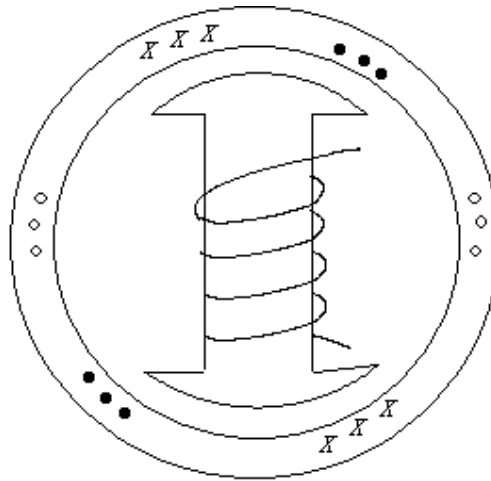

FigP1

Although it shows three stator windings, it is still a single-phase device. Any a.c. current in the rotor will produce at “stand-still” three stator voltages which are in time phase. Two of these devices in the circuit of Fig P2 provides a system for transmission of motion.

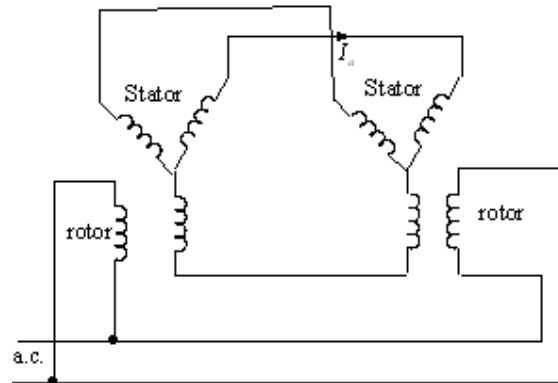

FigP2

It is assumed that the generator and motor are similar units and that for the initial conditions the voltages produced on the stator of the generator by the generator rotor are equal in magnitude and  $180^\circ$  out of phase with those produced by the motor rotor in the motor stator. Under these conditions the stator currents will be zero and no torque will be present in either machine.

If the rotor of the generator is turned through an angle  $\theta$  while the position of the rotor of the motor is left unchanged, a circulating current  $I_a$  will result in the stators. The current acting on the air gap flux will tend to restore the generator to its original position. The current will produce a torque in the motor which will tend to cause the rotor of the motor to assume an angle corresponding to that occupied by the rotor of

the generator. If the rotor of the motor is free to turn, it will follow the angular position of the generator rotor. The rotor of the motor therefore is an indicator of the position of the generator rotor or any device connected mechanically to it.

**Selsyns as position indicators:** If the circuit to the rotor of the motor is opened (Fig P3) a voltage will be produced in the rotor winding, the magnitude of which is a function of the angular position of the rotor of the motor w.r.t. that of the generator rotor. When the motor rotor is at a position of 90 electrical degrees from the position occupied and the rotor is electrically connected and free, the magnitude of the rotor voltage will be zero. Then any movement of the generator rotor will produce a voltage in the motor rotor which is a function of the angular position of the generator rotor (or other equipment coupled to it). This circuit has found use in many servomechanism systems. For this application the motor unit serves just as a control transformer.

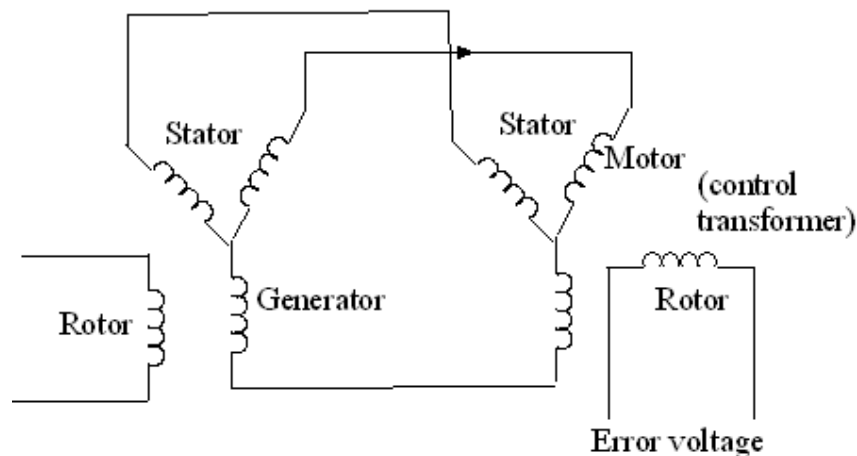

Fig P3

A third useful application of the selsyn system is that of the differential selsyn shown in Fig P4; this is constructed like a wound rotor induction motor having a 1:1 ratio of turns. When the rotors of the motor and generator of Fig P3 are in a given position, the differential selsyn will adjust the position of the rotor to its stator such that minimum current flows in its windings. With the rotor of the motor locked in a particular position, a change in the position of the generator rotor will cause a corresponding change in the position of the rotor of the differential selsyn. In this way the circuit of Fig P4 performs the same function as that shown in Fig P3.

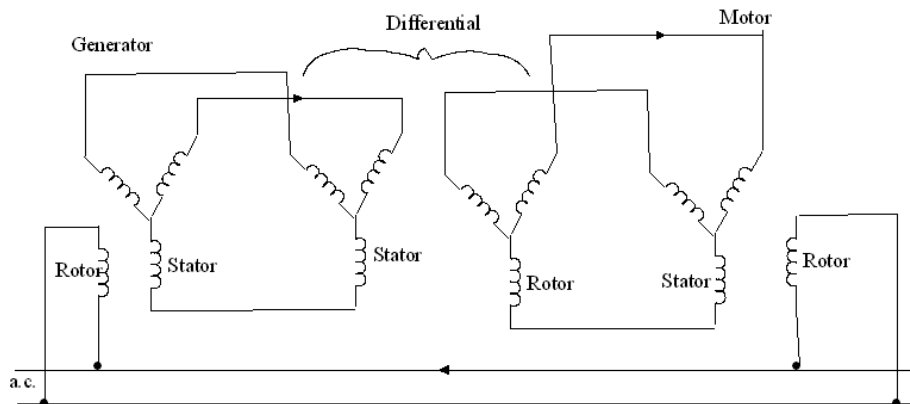
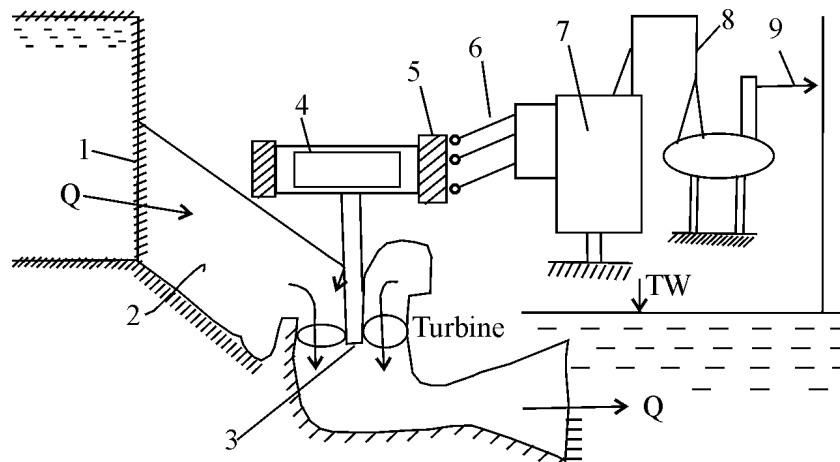

Fig P4

**Q.17** Give the layout of a hydro – electric power plant and briefly explain the working of any two of its main components. (14)

**Ans:** A typical hydroelectric development consists of a dam, which raises the water surface of the stream to create head, pondage, storage or the facility or diversion into conduits, an intake containing racks and gates to control the flow into the conduits, a conduits system to convey the water to the turbines which transform the energy of the water into mechanical energy, generators to transform the mechanical energy of the hydraulic turbines into electrical energy, a power house to contain the turbines, generators and accessories and a draft tube to convey the water from the turbine to the tailrace which leads back to the stream.

The principle of operation of a hydroelectric station can be grasped from a reference to Fig C3



**Fig. C3** Principle of operation of a hydroelectric plant



From the reservoir, the water flows through the intake 1 and penstock 2 to the hydraulic turbines 3. On flowing through the turbines where it gives up its energy, the water flows through the draft tube to the tail race. The turbine rotates the rotor of the generator 4. As a result, electric current is induced in the generator stator 5. The current is conveyed via the buses 6 to the step-up transformer 7, and then to the switchgear 8. From the switchgear, the current is directed through the power lines 9 to the loads.

Two of its main components are described below:

### **Hydraulic Turbines**

A hydraulic turbine is a prime mover which transforms the energy of falling water into mechanical energy of rotation and whose primary function is to drive a water wheel hydroelectric generator. The turbine runner and rotor of the water wheel generator are usually mounted on the same shaft, which is why the entire assembly is frequently referred to as the turbo-generator.

An impulse turbine is one in which the driving energy is supplied by the water in kinetic form; and a reaction turbine is one in which the driving energy is provided by the water partly in kinetic and partly in pressure form.

### **Switchgear**

The functions of the switchgear may be briefly summarized as follows

- (i) To localize the effects of faults by operation of protective equipment and to automatically disconnect faulty plant from the system.
- (ii) To break efficiently, short-circuits without giving rise to dangerous conditions.
- (iii) To facilitate re-distribution of loads, inspection and maintenance of the system.

The design and construction of the switchgear layout should be such that a reliable service is obtained under all operating conditions and in, as direct a route as possible from the alternators to the outgoing feeders. The choice of suitable switchgear is governed by the maximum short circuit-MVA it is called upon to deal with and also to some degree upon its relation to the system of which it forms a part. The figure of short circuit MVA is needed for installing suitable circuit breakers.

**Q.18** Write notes on:

- (i) SF<sub>6</sub> Circuit Breaker.
- (ii) Mhos Relay.

**(14)**

**Ans: Notes on SF<sub>6</sub> circuit breaker**

SF<sub>6</sub> is a heavy chemically inert noninflammable gas. Its other properties are:

- At atmospheric pressure its dielectric strength is two to three times that of air. As a consequence reduced electrical clearance would be sufficient.
- Its heat transferability at atmospheric pressure is about 2.5 times that of air; therefore smaller conductor sizes are needed.
- It is chemically stable at temperatures at which oil begins to oxidize and decompose.
- It is electronegative and its molecules rapidly absorb free electrons in the arc path forming heavy slow moving negative ions, which are ineffective as current carriers. Hence it has superior arc quenching ability.
- Its heat capacity below 6000 K is much larger than that of air and helps in continuous cooling of the arc zone.
- Its arc time constants is a few  $\mu s$ . With the combination of superior insulating and arc-quenching properties, SF<sub>6</sub> breakers have a very wide range of application-6.6 KV to 765 KV and 20-60 KA rupturing capacity.

The properties of SF<sub>6</sub> are such that the gas blast speeds need not be as high as in ABCB.

The main advantages of SF<sub>6</sub> circuit breakers are as follows:

- Low gas velocity and pressures employed prevent current chopping; capacitive currents are interrupted without restriking.
- There is no exhaust of high pressure gas to atmosphere, and their operation is silent.
- There is short time arc, low contact erosion and no contact replacement.
- No carbon deposition takes place and hence there is no insulation tracking.
- The smaller size of conductors and clearances lead to small overall breaker size; and these have ample overload margin.
- They are non inflammable

**Mhos relay:** An impedance relay has a characteristic given by

$$K_1 |I|^2 + K_2 |V|^2 > 0$$

or

$$\left| \frac{V}{I} \right| = |Z| < \left( \frac{K_1}{-K_2} \right)^{1/2} = |Z_{rs}|$$

If  $K_2$  is made negative, such a relay senses impedance magnitude, and operates if the magnitude of impedance seen from its location (in any direction) is less than a specified value. Since  $|V|$  prevents relay operations,  $K_2$  being negative, and  $|I|$  tries to operate it, voltage is the restraining quantity and current is its operating quantity.

A modified impedance relay called mho relay results if a directional relay is restrained by voltage. Thus

$$Q = K_2 |V| |I| \cos(\theta - \tau) - (-K_1) |V|^2 - K_4$$

Neglecting  $K_4$ , the inequality for relay operation becomes

$$K_3 |V| |I| \cos(\theta - \tau) - (-K_1) |V|^2 > 0$$

or

$$\left| \frac{V}{I} \right| = |Z| < \frac{K_3}{-K_1} \cos(\theta - \tau) \quad \text{--- (1)}$$

The right hand side of Eqn (1) is a circle with centre located in the line determined by the parameter  $\tau$  and passing through the origin as shown in Fig D3. The characteristic in this case is inherently directional. This characteristic can be alternatively expressed as

$$|Z - Z_{rs}| < |Z_{rs}| : \text{trip}$$

$$|Z - Z_{rs}| > |Z_{rs}| : \text{block}$$

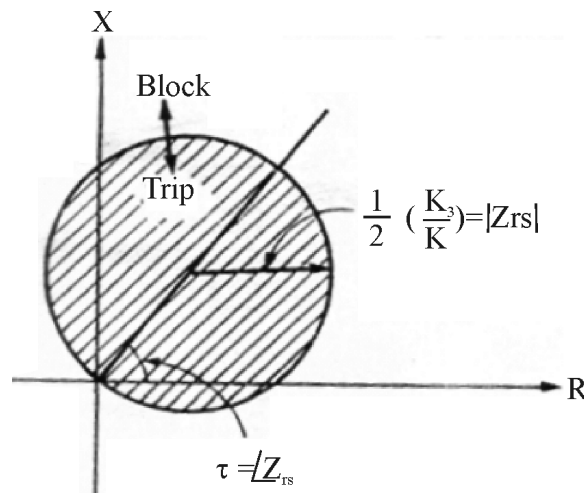

Fig. D3 Rx-diagram of a mho relay

**Q.19** Write short notes on any **TWO** :-

- (i) Servo motor.
- (ii) A.C. Tacho generator.
- (iii) Explain the principle of induction heating.
- (iv) What is welding process and explain principle of electric welding. (14)

**Ans:**

- (i) **Servomotor:** Servomotors are of two kinds, d.c. and a.c. These are described below:

**D.C. Servomotor** A DC servomotor is often employed in a control system where an appreciable amount of shaft power is required. These servomotors have separately excited fields. They are either armature controlled with fixed field or field controlled with fixed armature current. For example, the DC servomotor [Fig E3] used in instruments employs a fixed permanent magnet field, and the control signal is applied to armature terminals.

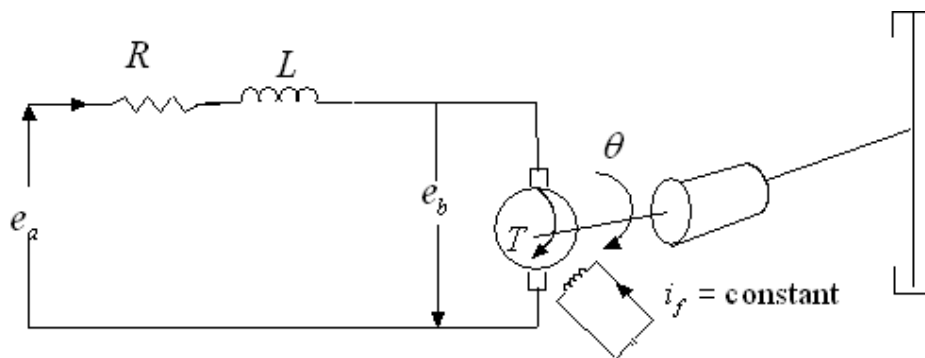

**Fig. E3**

The two-phase ac servomotor [Fig E4] on the other hand is ideally suited for low power control applications. The two phases are called control phase (phase a) and reference phase (phase m), the latter being excited at a fixed magnitude of synchronous a.c. voltage, both voltages being taken from the same source

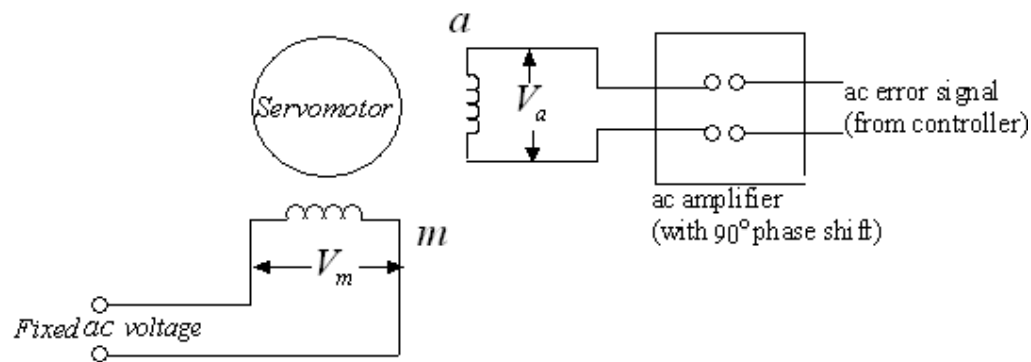

Fig. E4 Control scheme for 2-phase servomotor

The control phase voltage is shifted in phase by  $90^\circ$  from the reference phase voltage by means of phase shifting networks. The motor torque gets reversed by phase reversal of control phase voltage. This motor has low rotor inertia and hence faster response; also it has no brushes that contact the commutator segments.

(ii) **A.C. Tachogenerator:** An a.c. tachogenerator is nothing but a 2-phase induction motor with one phase 'm' excited from the carrier frequency, while the phase 'a' winding is left open-circuited as shown in Fig E5. To archive a low inertia, a rotor drag cup is commonly employed. It can be shown that the voltage across phase 'a' is proportional to the rotor speed whereas it has a phase shift of nearly  $90^\circ$ .

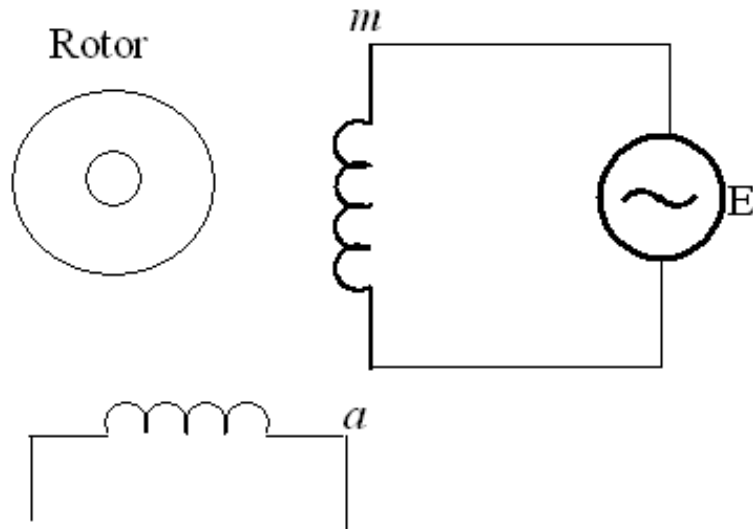

Fig E5 A.C. Tachogenerator

A.C. tachogenerators are quite commonly used in 400Hz control systems. High precision construction is required to maintain concentricity and to prevent any direct coupling between the two phase windings. Pick-up from stray fields is eliminated by soft –iron shields.

**(iii) Induction heating:**

Induction heating processes make use of currents induced by electromagnetic action in the material to be heated. Induction heating is based on the principle of transformers, there is primary winding through which ac current is passed. The coil is magnetically coupled with the metal to be heated. An electric current is induced in this metal when the ac current is passed through the primary coil.

Applications:

- Surface hardening
- Deep hardening
- Tempering
- Soldering
- Melting
- Smelting etc.

**(iv) Electrical welding**

Welding is the process of joining metals of similar composition by heating to suitable temperature with or without application of pressure and addition of filler material. The result of welding is a continuity of the homogeneous material and is of the same composition and characteristics as the parts, which are joined together.

Welding process may be classified as :

- (i) **Pressure welding:** The process in which the metal parts to be joined are heated to a plastic stage and then joined by applying external forces are known as plastic or pressure welding.
- (ii) **Fusion welding:** The process in which the metal parts to be joined are heated to molten state and then allowed to solidify joining a localized homogeneous union of the two is known as fusion welding.

Welding process may be further classified as:

- a. **Electric resistance welding:** Electric resistance welding is most commonly used kind of pressure welding. It can be applied to almost any metals with in certain limits of composition.

Principle of Electric Resistance Welding:

This process makes use of the heat generated by a heavy electric current passing through the materials being joined. The electric resistance between the surface in contact being mainly responsible for the rise in temperature. The heat generated bring these surfaces to the plastic state, at this point mechanical pressure is applied to squeeze the material together thus forming the joint.

Arc Welding: An electric arc is produced by bringing two conductors connected to a suitable source of electric current, firstly in contact and then separately by a small distance. The current continues to flow across the small gap and gives intense heat. The heat developed is utilized to melt the part of the work piece and the filler metal and thus form the joint. So the welded joint is the union of metal parts made by localized heat without any pressure.

Principle of Arc Welding:

Current from a source (ac or dc) is obtained. One terminal is connected to the electrode and to other to the work piece and the circuit is completed through air gap.

The gap is provided between the tip of the electrode and the surface of the work piece by keeping the electrode at a distance of about 3mm to 6 mm from the surface of the work piece. Due to the interruption by the air gap or gas, heat is produced and the temperature attained varies from  $3700^{\circ}$  to  $4000^{\circ}\text{C}$

- Q.20** (a) Discuss the criterion for choice of voltage for transmission and distribution. (8)  
 (b) Explain principle of carrier current protection and communication. (8)

**Ans: (a) Criterion For Choice Of Voltage For Transmission And Distribution.**

We know that the power  $W = VI$ , so for the same power if voltage is increased then current will decrease. If suppose power required is 500 W and voltage is 250 V then current I will be equal to  $500/250 = 2\text{A}$ .

Now if voltage is increased from 250V to 500V and the power required is same then  $I = 500/500 = 1\text{ A}$

Now, if the voltage is still increased to say 1000V for the same power then  $I = 500/1000 = 0.5\text{ A}$

From the above examples, we see that if the voltage is doubled, the current will be halved and when it is quadrupled then current is reduced to  $1/4^{\text{th}}$  of its initial value.

Thus we conclude that if voltage is increased to n times then the current will be reduced to  $1/n^{\text{th}}$  times for the same power. With the reduction of the current to  $1/n^{\text{th}}$  times, the conductor area will also be reduced to  $1/n^{\text{th}}$  times of its original area for the same current density, Hence less material is required when the voltage is increased

We also know that when the current passes through any conductor, there is loss of power in that particular conductor according to the relation,  $I^2 R$ . As the loss is proportional to the square of the current. So if the current is reduced to  $\frac{1}{2}$  value, then the loss will be reduced to  $\frac{1}{4}$ <sup>th</sup> its original value. Hence the efficiency of the transmission line and all others equipments associated with the line will increase and more power will be available for use.

When current is passing through a conductor there will be a voltage drop according to the relation  $V=IR$ . So, when the current is reduced the drop of the voltage is less in the line, of course with the same cross sectional area of the conductor.

With the reduction of cross sectional area, considered the main advantage of transmitting electrical energy at very high voltage viz 132kV, 220kV or even 400kV.

But in case of distribution system such high voltage is dangerous, so distribution voltage is generally 400/230V.

**(b) Principle of carrier current protection and communication:**

This type of protection is used for protection of transmission lines. Carrier current frequency ranges from 35kHz to 500kHz are transmitted and received through the transmission lines for the purpose of protection. Each end of the line is provided with identical carrier current equipment consisting of transmitter, receiver, line – tuning unit, master oscillator, power amplifier etc. The carrier equipments is connected to the transmission line through “Coupling capacitor” which is of such a capacitance that it offers low reactance to carrier frequency but high reactance to power frequency.

Thus coupling capacitor allows carrier frequency signals to enter the carrier equipment. A line trap unit is inserted between bus bar and connection of coupling capacitor to the line. It offers low impedance to 50Hz and high impedance to carrier frequencies. This unit prevents the high frequency signals from entering the neighboring line, and carrier currents flow only in the protected line.

Frequencies between 50 to 500 kHz employed in different frequency bands through transmitter carrier frequencies are generated in oscillator. The oscillators can be tuned to a particular frequency selected for the application. The output of the oscillator is fed into the amplifier to overcome the losses in the transmission path between the transmitter and the receiver at remote end of the line.

The high frequency signals arriving from remote end are received by receiver. Receiving unit comprises an attenuator, which reduces the signals to a safe value. Band pass filter, which restricts the acceptance of unwanted signals. Matching transformer or matching elements to match the impedances of line and receiving unit.

Different frequencies are used in adjacent line sections. The choice of frequency bands for various sections should be coordinated. The modulator, modulates 50Hz



signals and the modulated signal is fed to the amplifier and is then transmitted via coupling unit.

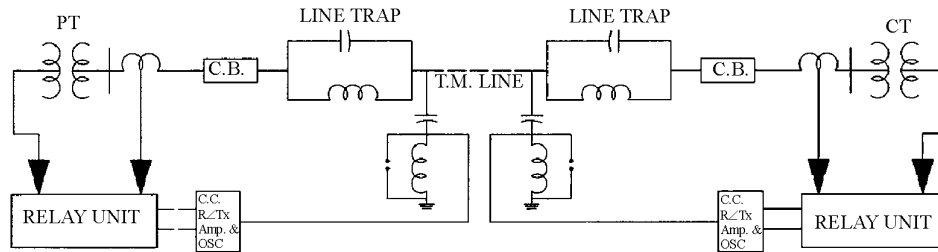

- Q.21** What are the various types of electric drives? Compare their advantages and disadvantages. State and explain the various factors which affect the selection of an electric motor as industrial drive. **(14)**

**Ans: Various type of electric Drives:** A variety of thyristor or power semiconductor control circuitry has been devised for motor control (also called electric drives), depending upon the type of supply (ac/dc) and the type and size of the motor.

For dc motor control, controlled dc power from a constant voltage ac supply is obtained by means of controlled rectifiers employing thyristors and diodes. The control of d.c. voltage is achieved by firing the thyristors at an adjustable angle with respect to the applied voltage. This angle is known as the ‘firing angle’ and the scheme of control is called the phase control. Control of d.c. motors fed from dc supply is also achieved by means of d.c. choppers which are d.c.-d.c. converters. This type of controller periodically opens and closes the switch; thus the average voltage is controlled by varying the ‘on’ and ‘off’ durations. It gives an efficient and stepless control of dc motors. However the choppers controller requires forced commutation of thyristors which involves special thyristorized circuitry.

Closed-loop control of d.c. drives usually involves one or more feedback loops. The relevant signals are sampled through transducers at discrete instants for computational purposes; also switching of power semiconductor devices is accomplished by gate/base control. Fig M14 shows a block-cum schematic diagram of a typical separately excited d.c. drive which has an outer speed loop and an inner current control loop. The motor speed is sensed by a tachometer, the output of which is fed through an A/D converter to the microcomputer. However a shaft encoder can also be used for this purpose, and the digital output of the shaft encoder can be directly fed to the microcomputer. The armature current of the motor can be sensed by measuring the voltage across a standard resistor.

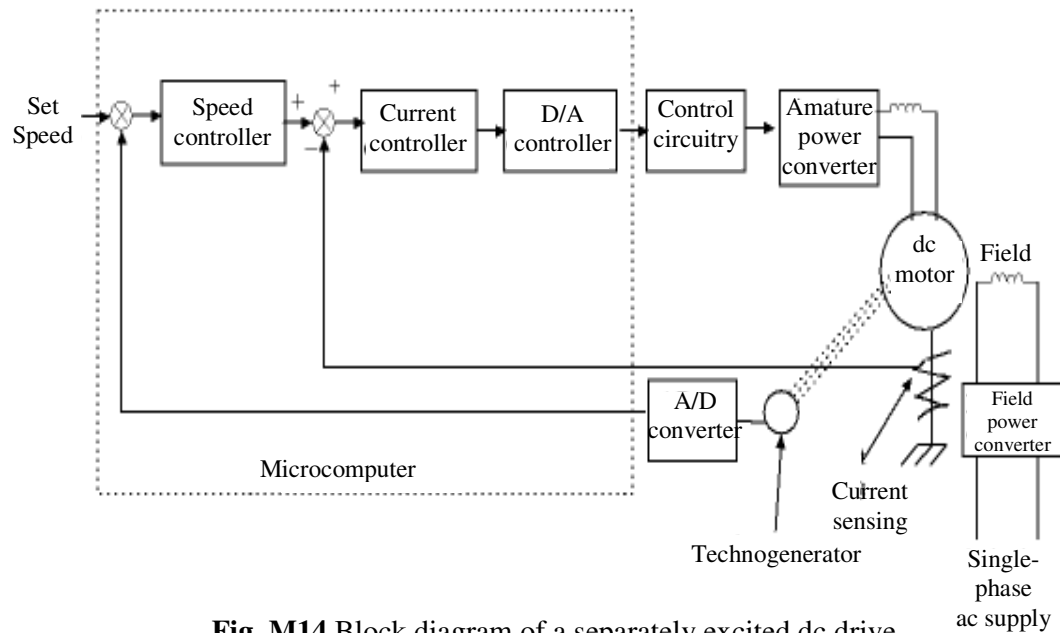

**Fig. M14** Block diagram of a separately excited dc drive

Till recent times variable speed drive application were dominated by d.c. motors. Squirrel cage induction motor which costs approximately one – third of a d.c.-motor of the same rating, is quite rugged, maintenance free, can be built for higher speeds, torques and power ratings. Wound rotor induction motors, through costlier than squirrel cage ones, also need less maintenance and are available in higher power ratings. Thus a.c. drives have succeeded in replacing dc drives in a number of variable speed applications. For control of a.c. motors that include both types of induction motors as well as synchronous motors fed from d.c. supply, thyristor, transistor or MOSFET based inverters are employed. These semiconductor switching circuits transfer energy from dc supply to an a.c. load of variable frequency and/or variable voltage. The switching operation results in considerable harmonics in the input a.c. waveforms which are filtered out by the a.c. motor. The normal power supply being of the a.c. type, the complete scheme involves a converter and then an inverter.

A cycloconverter is a direct a.c. to a.c. converter for obtaining variable voltage low frequency a.c. supply from a fixed frequency one. Thus it eliminates the necessity of an intermediate d.c. stage. In spite of their direct a.c. to a.c. conversion the cycloconverters have the disadvantages that

- (i) They produce a subfrequency output,
- (ii) their output contains a high harmonic content, and

(iii) the input power factor is low. Cycloconverters are used for low-speed drives and controlling linear motors in high-speed transportation systems.

**Q.22** Write notes on any **TWO** :-

- (i) Induction Furnace.
- (ii) Buchholz's Relay.
- (iii) Inductive interference. (14)

**Ans:**

(i) **Induction Furnace:** Induction heating processes make use of currents induced by electro-magnetic action in the material to be heated. It is, however only in materials of low resistivity such as metals that sufficient currents to cause effective heating can be produced. For this purpose it is often necessary to use a magnetic field of very high frequency. For melting or refining metals, various kinds of induction furnaces are available, while for other purposes such as case hardening and soldering, the necessary currents are induced in the article at the appropriate stage of its manufacture; the latter process requires a high frequency and is called as the high-frequency eddy current heating.

The core type furnace is essentially a transformer in which the charge to be heated forms the secondary circuit and is magnetically coupled to the primary by an iron-core as shown in Fig N1. It can be seen from this figure that the magnetic coupling between the primary and the secondary is poor. The electromagnetic forces cause turbulence of the molten metal which, although useful upto a point, is liable to become to severe. A crucible of inconvenient shape from metallurgical point of view is used. In order to start the furnace, a complete ring of metal must be present in the crucible, otherwise the secondary circuit will not be complete.

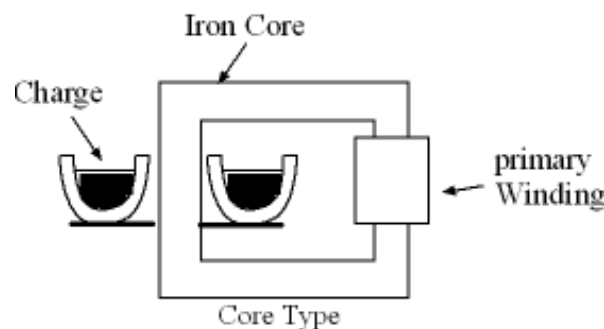
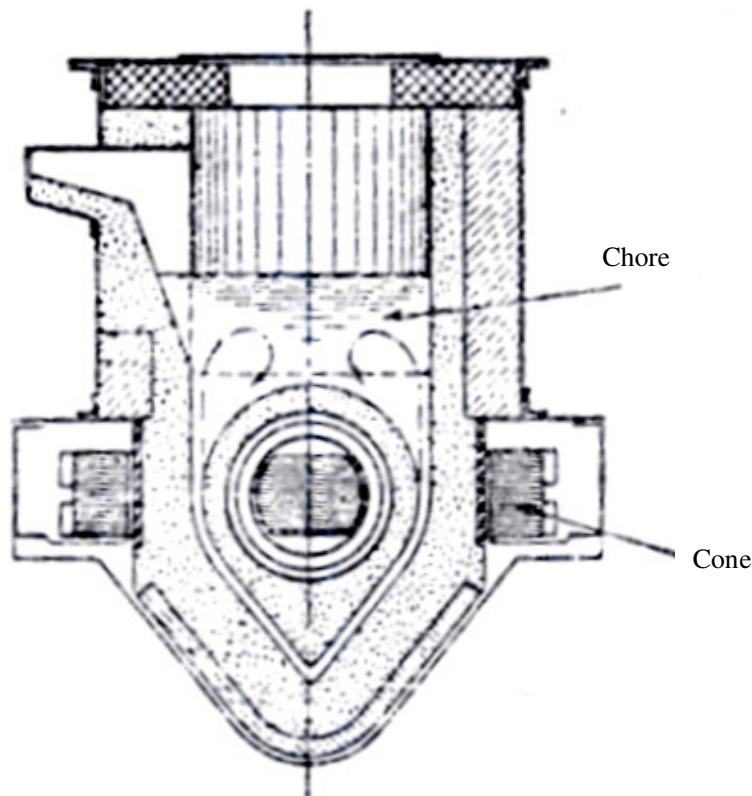

Fig N1

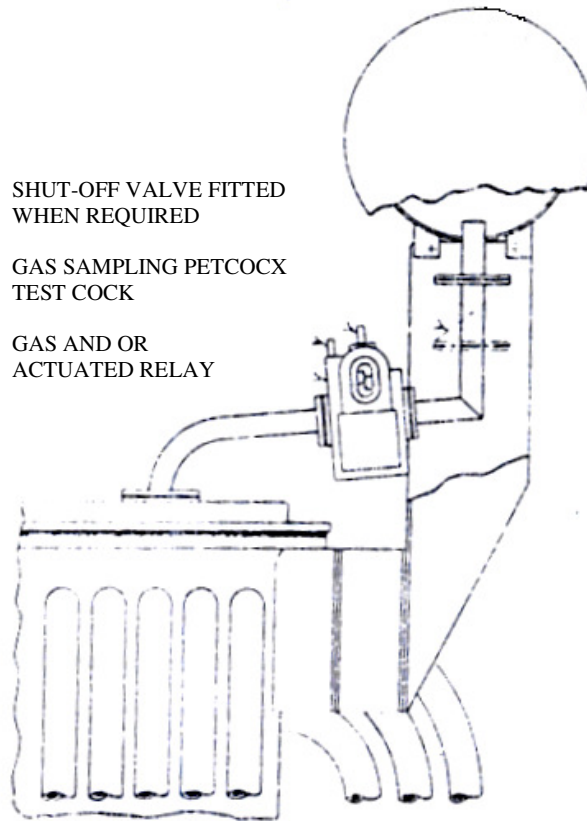

**Fig. N2** Ajax-Wyatt Vertical Core-type Furnace

An improvement over the conventional core type furnace is the vertical core type furnace which overcomes some of the above mentioned difficulties. It is known as the Ajax-Wyatt furnace [Fig N2] and uses a vertical instead of horizontal channel for the charge. The tendency of the circuit to repute due to the pinch effect is counteracted by the weight of the charge in the main body of the crucible. The circulation of molten metal is kept up round the Vee portion by convection currents and by the electromagnetic forces between the currents in the two halves of the Vee. Such a furnace is very widely used in foundries for melting and refining brass and other non-ferrous metals.

(ii) **Buchholz's relay** : The Buchholz's relay is a gas operated relay in which the development of a fault within the transformer, particularly in the incipient stage is guarded. Also major breakdowns and sudden disruption of supply are avoided, thus making it a very reliable piece of electrical equipment. It is fitted to transformers having conservator vessels and is installed in the pipeline between the transformer and its conservator tank. The relay comprises an oil tight container fitted with two internal floats which contain mercury switches connected to external alarm and tripping circuits. Normally the device is full of oil and the floats, due to their buoyancy rotate on their supports until they engage their respective stops.

- a) An incipient fault within the transformer generates small bubbles of gas which pass upward, towards the conservator, become trapped in the top of the chamber, thereby, causing the oil level to fall. The upper float gets deflected as the oil level within the relay falls and when sufficient oil has been displaced, the mercury switch contacts close, thus completing the electrical alarm circuit.



**Fig. N3 Arrangement for mounting the gas and oil actuated relay (Buchholz's relay)**

- b) For a serious fault within the transformer, the gas generation is more violent and the oil displaced by the gas bubbles flows through the connecting pipe to the conservator. This abnormal flow of oil causes the lower floats to be deflected thus actuating the contacts of the second mercury switch and completing the tripping circuit of the transformer circuit breaker, thus disconnecting the transformer from the supply. The arrangement for mounting the gas and oil actuated relay is shown in Fig N3.

**(iii) Inductive interference:** Inductive interference is said to occur when voltages are induced in adjacent communication lines by the unsymmetrically spaced power lines. Fig N4 shows

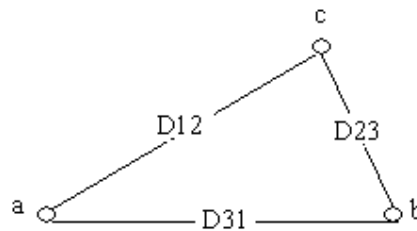

Fig. N4

the conductors of a three phase line with unsymmetrical spacing. For the purpose of this discussion it is assumed that there is no neutral wire so that the conductor currents sum upto zero. That is

$I_a + I_b + I_c = 0$  unsymmetrical spacing causes flux linkages and therefore the inductance of the three phases will be unequal. This results in unbalanced receiving end voltages even when sending end voltages and line currents are balanced. Also inductive interference occurs with the adjacent communication lines. This problem can be tackled by exchanging the positions of the conductors at regular intervals along the line such that each conductor occupies the original position of every other conductor over an equal distance. This change of conductor positions is called 'transposition'. A complete transposition cycle is shown in Fig N5

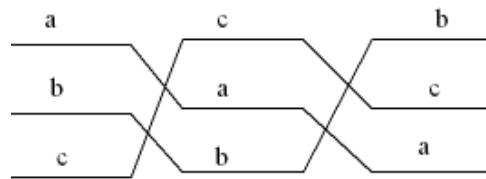

Fig N5 Complete transposition cycle

This arrangement causes each conductor to have the same average inductance over the transposition cycle. It can be shown that over the length of one transposition cycle, the total flux linkages and hence the net voltage induced in a nearby telephone line is zero and also that the power line transposition is ineffective in reducing the induced telephone line voltage

- i) when the power line currents are unbalanced (that is the sum  $I_a + I_b + I_c \neq 0$ ) or
- ii) when they contain third harmonics. These harmonic line currents are undesirable because:
  - a) the induced emf becomes proportional to the frequency and
  - b) higher frequencies come within the audible range. Thus there a need to avoid the presence of such harmonic currents on a power line from considerations of the

performance of nearby telephone lines. Another feature is that with unbalanced power line transposition apart from being ineffective, introduces mechanical and insulation problems. It is therefore easier to eliminate induced voltages by transposing the telephone lines instead. Some induced voltage will always be present on a telephone line running parallel to a power line because in actual practice transposition is never completely symmetrical. Therefore when the lines run parallel over a considerable length, it is a good practice to transpose both power and telephone lines. The two transposition cycles are staggered and the telephone line is transposed over shorter lengths compared to the power line.

**Q.23** Derive the emf equation of a transformer. (2)

**Ans:**

**(a) EMF equation of a transformer :-**

$N_1$  = no. of turns in primary

$N_2$  = no. of turns in secondary

$\Phi_m$  = maximum flux in core

=  $B_m A$

$f$  = frequency of a.c. input in Hz

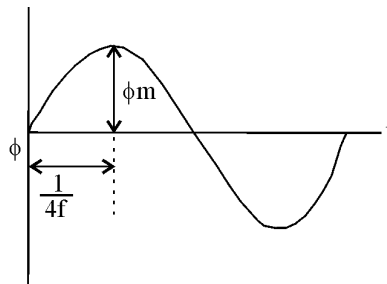

From figure, flux increases from its zero value to maximum value  $\Phi_m$  in one quarter of the cycle i.e.  $1/4f$  second

Average rate of change of flux =  $\Phi_m / (1/4f)$

$$= 4 f \Phi_m \text{ Wb/s}$$

Rate of change of flux per turn means induced emf in volts

Average emf/turn =  $4 f \Phi_m$

If flux  $\Phi$  varies sinusoidally, then rms value of induced emf is obtained by multiplying the average value with form factor.

rms value of emf /turn =  $1.11 \times 4 f \Phi_m = 4.44 f \phi_m$

rms value of emf induced in whole of primary winding = induced emf/turn  $\times$  no of turns

$$= 4.44 f N_1 \phi_m$$

similarly, rms values of emf induced in secondary winding =  $4.44 f N_2 \phi_m$

**Q.24** Draw the characteristic curves and state two applications for

(i) a dc shunt motor

(ii) a dc series motor.

(4)

**Ans:**

**3(a) Characteristic curves & applications**

**D.C. shunt motor :-**

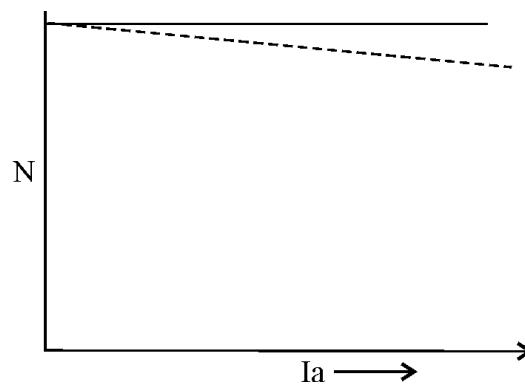
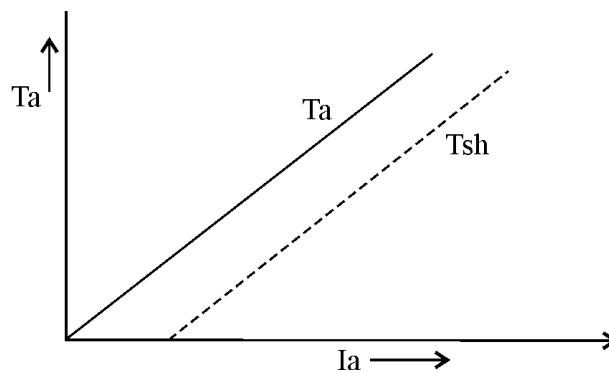



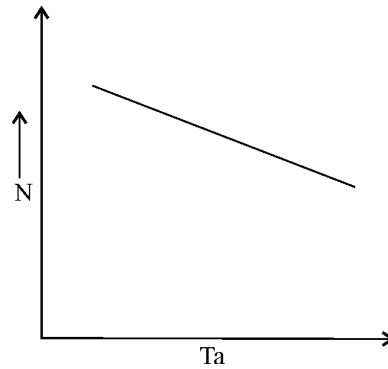

**Applications :-** Due to the constancy of their speed shunt motors are suitable for driving shafting, machine tools, lathes, wood working machines and for all purposes where an approximately constant speed is required.

**DC Series Motor:-**

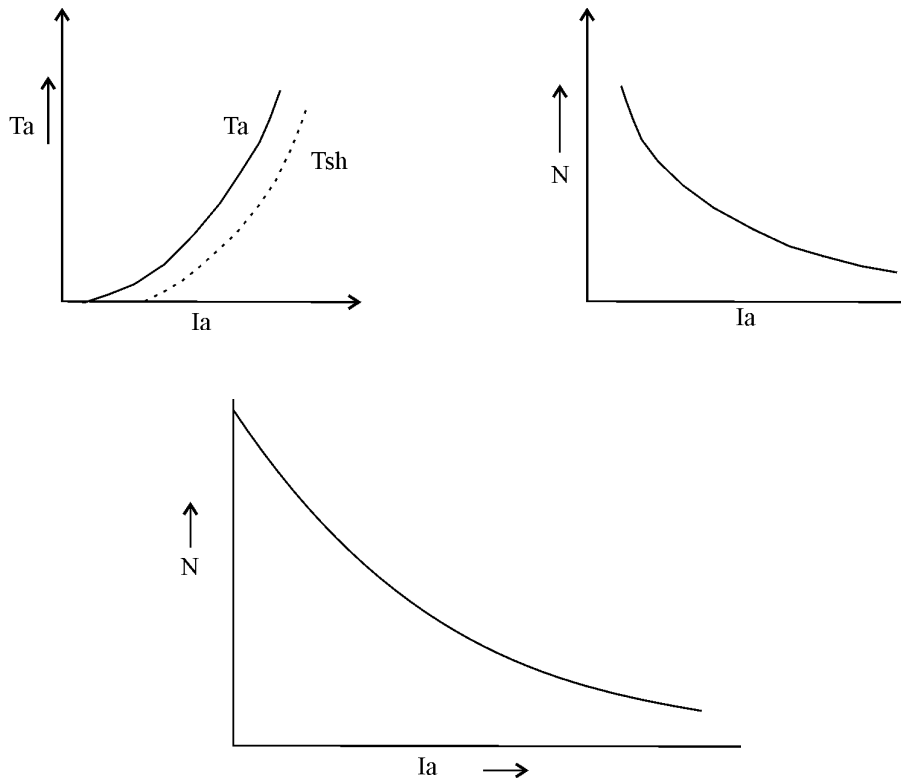

**Applications:-** Traction work, trolley cars, hoists & cranes, conveyors — etc.

**Q.25** With a neat diagram explain the working of a universal motor. Also draw its torque-speed characteristics when it is fed from both ac & dc sources. (7)

**Ans:**

**4. (a) Universal motor :-**

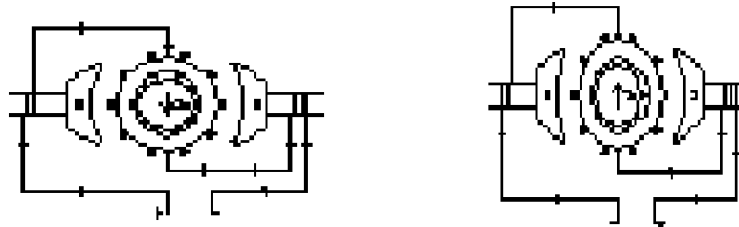

A universal motor develops unidirectional torque regardless of whether they operate on DC or AC supply. The production of unidirectional torque when the motor runs on AC supply can be understood from the above figures. The motor works on the same principle as a DC motor i.e. force between the main pole flux and the current carrying armature conductors. This is true regardless of whether the current is alternating or direct. The rotor is same in construction to that of a DC motor but the stator is laminated necessarily because the flux is alternating when the motor is operated from AC supply.

**Torque speed characteristics :-**

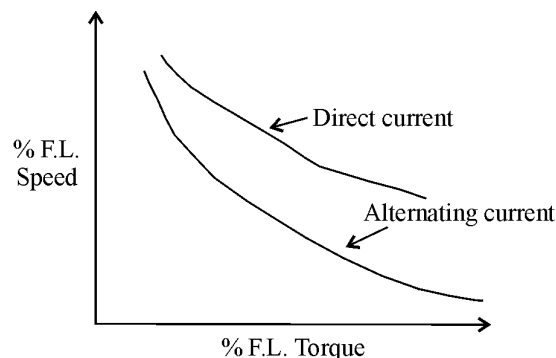

**Q.26** Explain the construction, working and applications of a stepper motor. (7)

**Ans:**

**Stepper motor :-**

**Construction:** Stepper motor consists of a slotted stator equipped with two or more individual coils and a rotor structure that carries no winding. The classification of the stepper motor is determined by how the rotor is designed. If the rotor is made up of a permanent magnet, it is called a PM stepper motor. If no magnet exists on the rotor (only a rotor core) it is called a reluctance type stepper motor. The presence of the permanent magnet in the rotor furnishes the motor with the equivalent of a constant DC excitation.

**Operation:-**

The elementary operation of a four phase stepping motor with a 2-pole rotor is explained below.

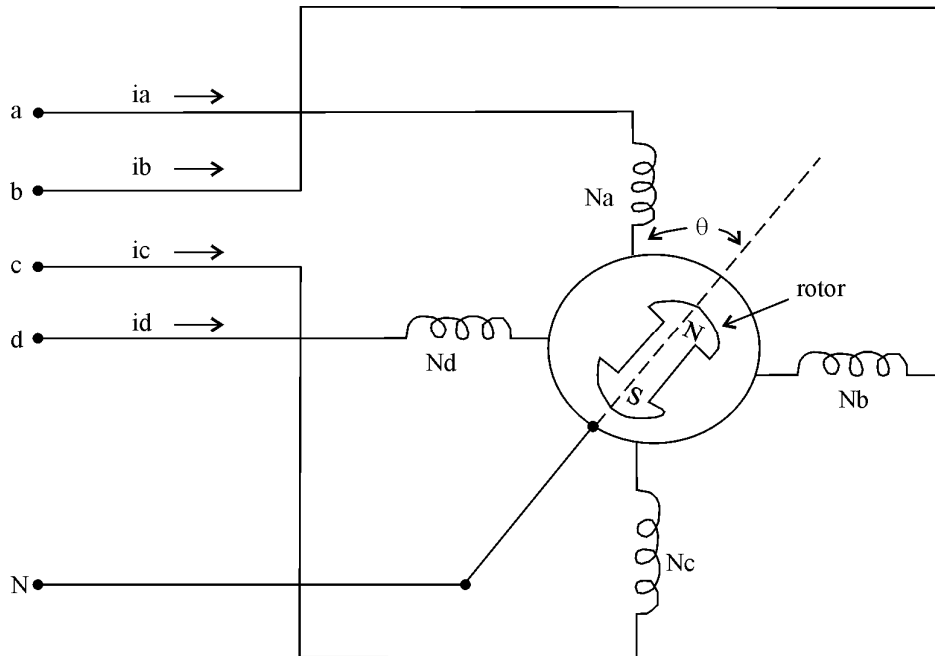

With the above construction of a stepper motor the rotor assumes the angles  $\theta = 0^\circ, 45^\circ, 90^\circ, 135^\circ, 180^\circ \dots$  etc. as the windings are excited in the sequence of  $N_a, N_a + N_b, N_b, N_b + N_c, N_c \dots$  etc.

The same motor can also be used for  $90^\circ$  steps by exciting the coils singly i.e.  $N_a, N_b, N_c, N_d$  only. For the use of  $90^\circ$  steps only the permanent magnet rotor can be used.

**Applications :-**

- (1) Typewriters, printers
- (2) Positioning of disk drives
- (3) Plotters
- (4) Recording heads in computer disk drives
- (5) Worktable and tool positioning in CNC machines.

Major advantage of using stepper motors is that no feedback is required from the rotor to ascertain the angular position of rotor.

**Q.27** Compare the induction motor with a transformer.

(2)

**Ans:****5(a) Comparison of Induction Motor with a transformer :**

The transfer of energy from stator to the rotor of an induction motor takes place entirely inductively with the help of flux mutually linking the two. Hence an induction motor is essentially a transformer with stator forming the primary and rotor forming the rotating secondary.

Transformer	Induction Motor
(1) Secondary is stationary	(1) Secondary winding is rotating
(2) Secondary is not short circuited	(2) Secondary is always short circuited
(3) No-load current is about 1% of full load current (due to low reluctance path of steel core)	(3) No-load current is approximately 30 to 50% of full current (due to high reluctance of air gap)
(4) emf induced in secondary depends on K (turns ratio)	(4) Depends on K and slip also
(5) Frequency of primary and secondary currents are same	(5) Frequency of stator current (f) and rotor current (sf) are not the same.

**Q.28** Write short notes on **THREE** :-

- (i) Variable frequency operation of transformers.
- (ii) Armature reaction in dc machines.
- (iii) A C servomotors.

OR

Switched reluctance motors.

(5+5+4)

**Ans:**

### Variable Frequency Operation of Transformer

For power transformers frequency response is of no serious interest because these units are operated at a single fixed frequency. Frequency response is to be studied in communication circuits where the frequency of source voltage is likely to vary.

Equivalent circuit :

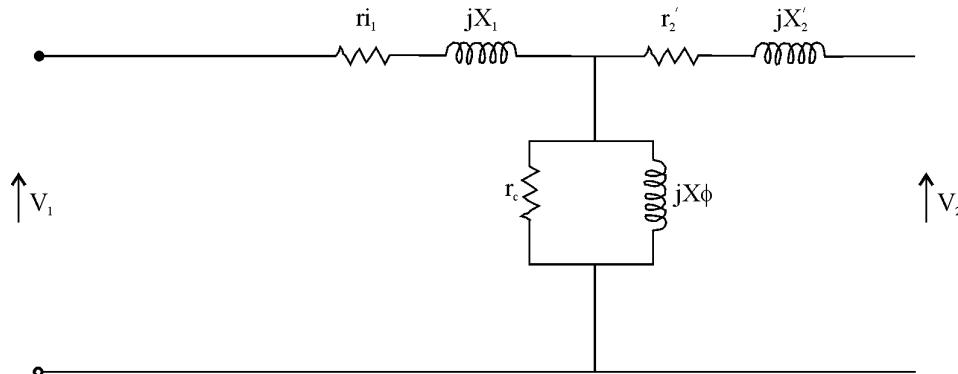

Frequency Response :

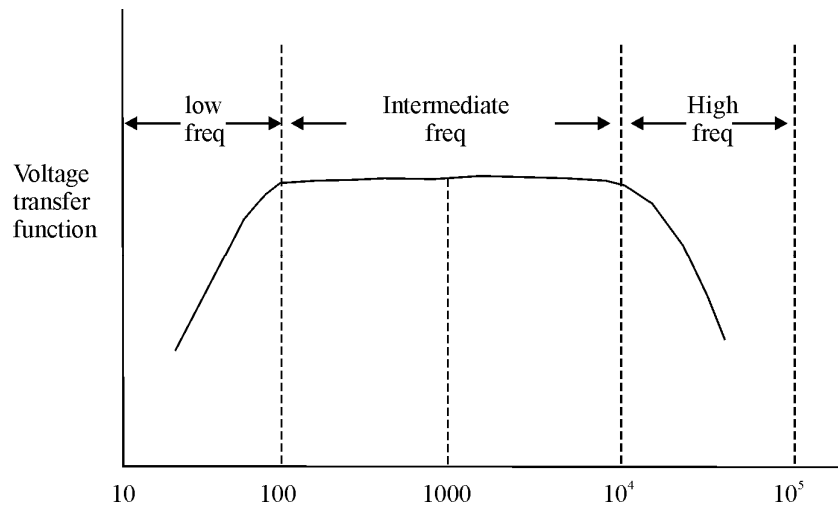

Fig (a)

**Low frequency: Fig(a)**

At low frequency  $x_\phi$  is a small, which causes a severe drop off of voltage by shunting the fixed load impedance.  $x_1$  and  $x_2$  are so small that these frequencies may be omitted from the diagram.

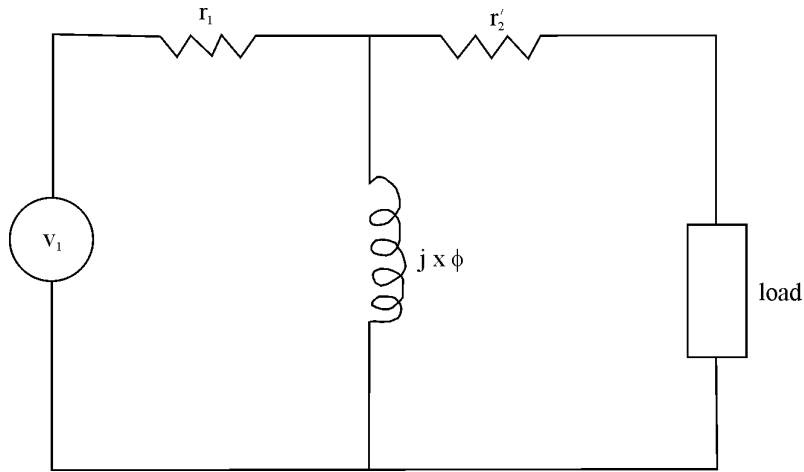
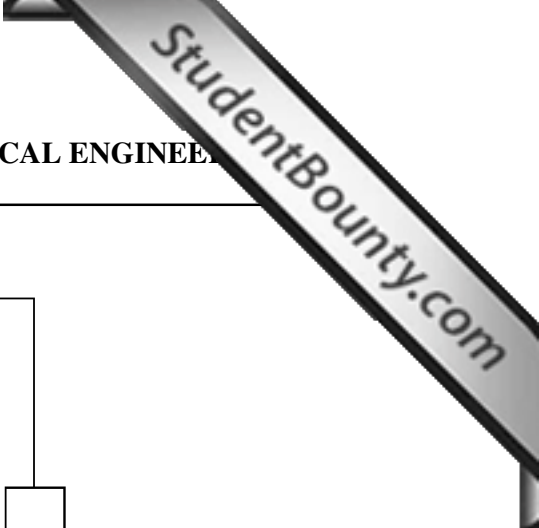

Fig (a)

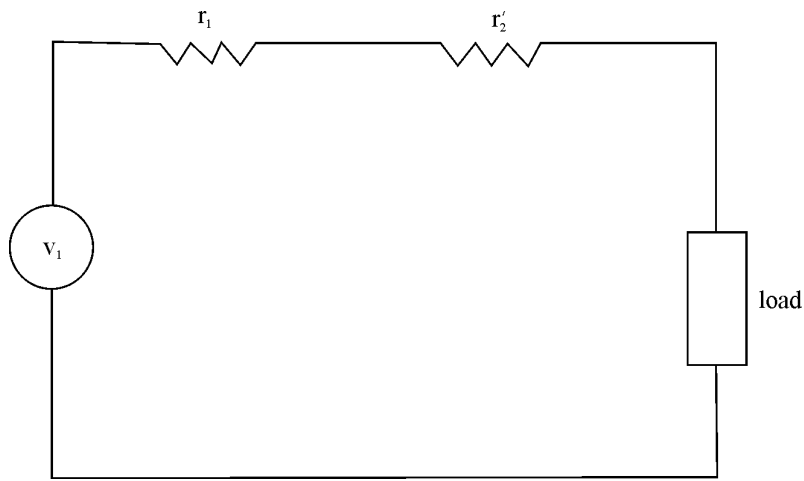

Fig (b)

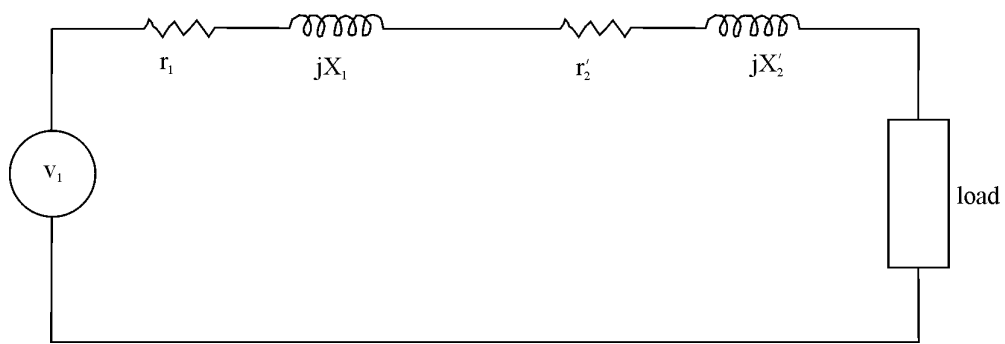

Fig (c)

**Intermediate frequency : Fig(b)**

At intermediate frequency,  $x_1$  and  $x_2$  are quite small while  $x_\phi$  is sufficiently large that it may be omitted. For a resistive load the equivalent circuit consists of solely resistive elements so that the transfer function remains constant over the band of intermediate frequencies.

**High frequency : Fig(c)**

At very high frequency,  $x_1$  and  $x_2'$  are no longer negligible and should be included. However  $x_\phi$  may be omitted. As the frequency increases the drop across  $x_1$  and  $x_2$  increases thereby causing a dip in the output voltage. Therefore the gain drops off as frequency increases.

**(ii) Armature reaction in DC Machines :**

Armature reaction is the effect of magnetic field setup by armature current on the distribution of flux under main poles of a generator. The armature reaction has two effects

1. Demagnetization- reduces the generated voltage and torque
2. Cross magnetization – distorts the field and causes sparking at brushes. Fig(a) Fig(b)

$I_a=0$  Fig (a)  $I_F=0$  Fig(b)

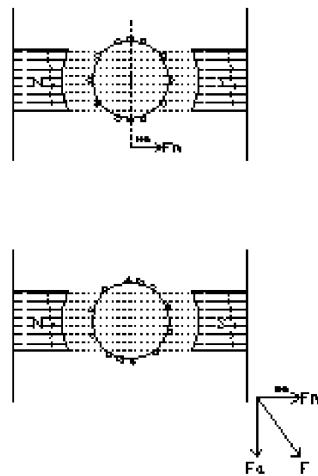

Both  $I_a$  and  $I_F$  are present

Fig(c)

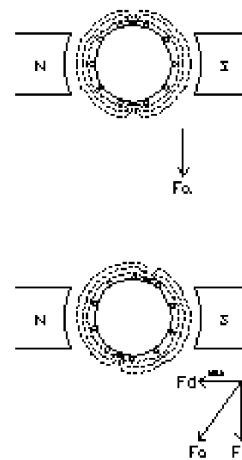

After brush shift :  $I_F = 0$

Fig(d)

When only  $I_F$  is present the, mmf is perpendicular to MNA (Figure (a)). When only armature current is present, mmf is along the MNA. When the machine is actually working, the resultant mmf vector is at an angle form MNA. This causes the brushes to be shifted to a new MNA perpendicular to resultant mmf. Now at this new MNA, mmf of  $I_a$  is along new MNA. This mmf is resolved into two component  $F_d$  and  $F_c$  which are demagnetizing and cross magnetizing mmf respectively.

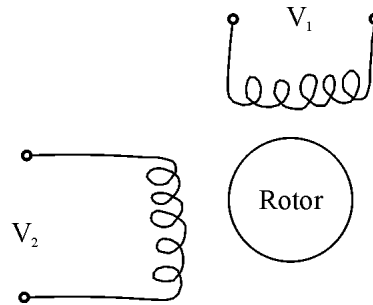
**(iii) AC Servomotors :**

An AC Servomotor is basically a two-phase induction motor except for certain special design features. A two phase induction motor consists of two stator windings oriented at  $90^\circ$ . Voltages of equal magnitude and  $90^\circ$  phase difference are applied to two stator phases, thus making their respective fields  $90^\circ$  apart in both time and space resulting in a constant magnitude RMF. The direction of rotation depends upon phase relationship of voltages  $V_1$  and  $V_2$ . The rotor is a short-circuited one producing torque in direction of field rotation. The torque speed characteristic is shown in the Fig.

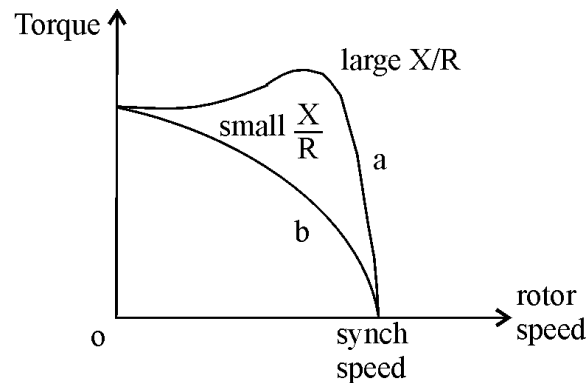

Generally a large  $X/R$  ratio is used in induction motor to have high torque at the operating region i.e. around 5% slip. But in a servomotor, for a small  $X/R$  the characteristic is nearly a linear in contrast to high nonlinear characteristic of large  $X/R$ . When large  $X/R$  is used for servo application because of the positive slope for part of characteristic (a) the system using such a motor becomes unstable.

**OR**

**(iii) Reluctance Motor :-**

It has either the conventional split phase stator and a centrifugal switch for cutting out the auxiliary winding after startup. The squirrel cage type rotor is of unsymmetrical magnetic construction. The rotor offers variable magnetic reluctance to the stator flux, the reluctance varying with the position of the rotor. The basic operating principle is that when a magnetic piece of material is located in a magnetic field a force acts on the material, tending to bring it



into the densest portion of the field. The force tends to align the specimen of material in such a way that the reluctance of the magnetic path that lies through the material will be minimum.

When the stator winding is energized the revolving magnetic field exerts reluctance torque on the unsymmetrical rotor tending to align the salient pole axis of the rotor with axis of the RMF (due to minimum reluctance). If the reluctance torque is sufficient to start the motor and its load, the rotor will pull into step with the rotating field and to run at the speed of the revolving field.

The switched reluctance machine is a special variation of the simple reluctance machine that relies on continuous switching of currents in the stator to guarantee motion of the rotor. It is also a true reluctance machine in that it has salient poles both in rotor and in the stator.

**Q.29** What do you understand by electric heating? State its advantages over other methods of heating. (7)

**Ans:**

### **Electric heating**

Electric heat is provided by use of a high temperature wire, which is resistant to electric flow with more heat being produced by more electric current being fed into the heating element, creating more resistance and more heat. This method of producing heat is called electric heating.

### **Advantage of electric heating:**

1. Cleanliness
2. Absence of flue gases, soot. ...etc/
3. Accurate control of temperature.
4. Low maintenance cost
5. Quicker operation
6. Higher efficiency
7. Uniform and economic heating capability

**Q.30** Describe the resistance welding method and name the other welding methods. (7)

**Ans:**

**Types of Welding :**

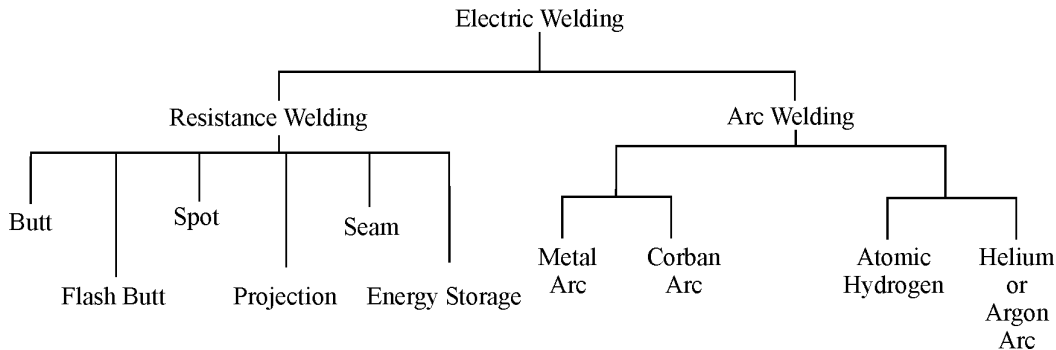

**Resistance Welding :**

Resistance welding is a process used to join metallic parts with electric current. In all forms of resistance welding, the parts are locally heated until a molten pool forms. These parts are then allowed to cool and the pool freezes to form a weld nugget. To create heat electric current is passed through work pieces. The heat generated depends on the resistance and thermal conductivity of the metal and the time for which the electric current is applied. The heat is expressed by the equation.

$$E = I^2 R t$$

E is the heat energy

I is the current

R is the electrical resistance

t is the time for which the current is applied.

**Q.31** List out the advantages of nuclear power plants over conventional thermal power plants. (4)

**Ans:**

**Advantage of Nuclear Power Plants**

1. Nuclear Power station reduces the demand for oil coal and gases.
2. Weight of nuclear fuel required for a given station capacity is negligible compared to that required for a conventional thermal power station. As a result the problems of transport and resulting costs are avoided.
3. The area and volume need for a nuclear power station is less in comparison to a conventional power plant of equal capacity.
4. In addition to producing large amount of power, a nuclear power plant produces valuable fissile material, which is extracted when the fuel is renewed.

**Q.32** Draw a flow diagram of a thermal power station and explain its main components.

(10)

**Ans:**

**Flow diagram of thermal power station :**

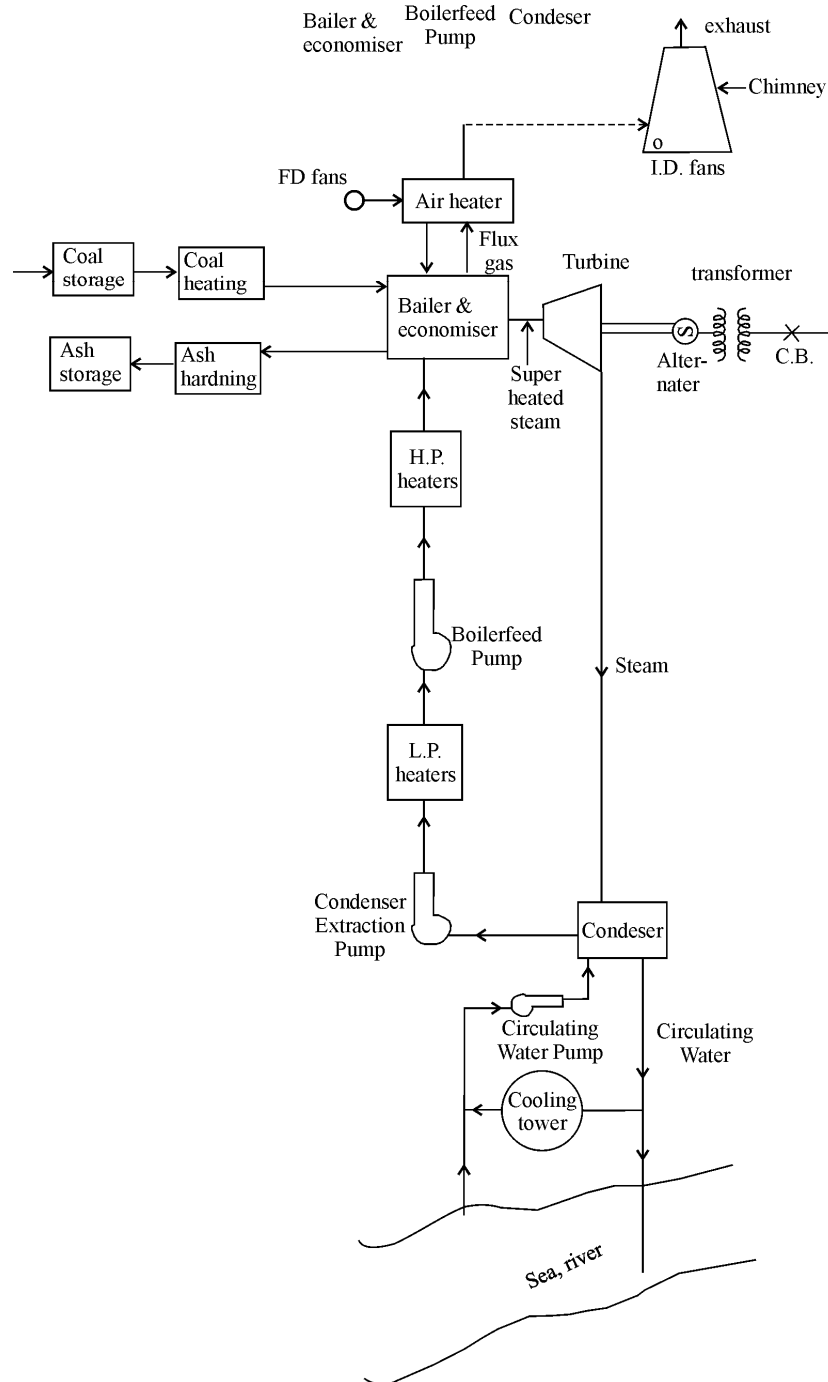

**Q.33** Draw the per phase equivalent circuit of a 3 phase induction motor and derive the expression for torque. (2)

**Ans:**

**(a) Per phase Equivalent circuit of Induction Motor**

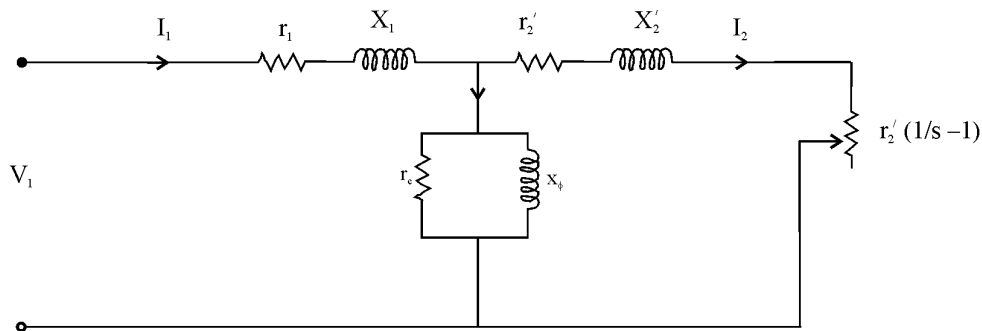

**Approximate equivalent circuit**

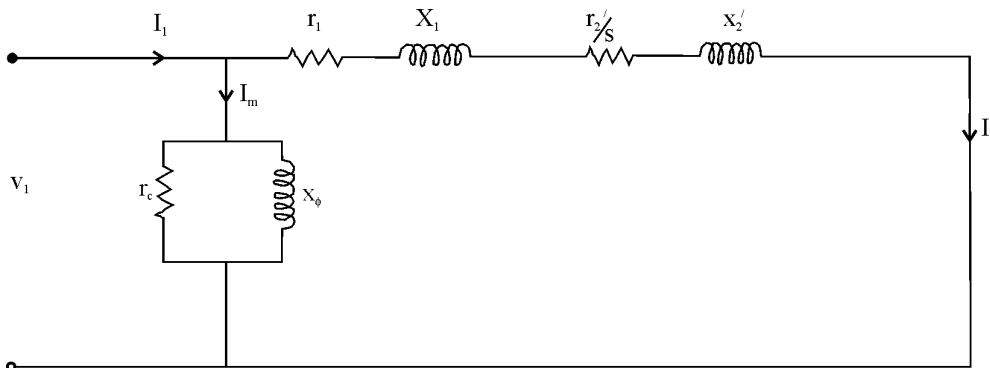

**Torque Equation:**

$$\text{Rotor input} = \text{torque} \times \omega_s$$

$$\text{Torque/phase} = \text{rotor input} / \omega_s = \text{rotor cu loss} / (\omega_s s)$$

$$\text{Total torque} = 3 I_2'^2 \frac{r_2'}{s \omega_s}$$

$$\text{But, } I_2' = \frac{V_1}{[(r_1 + \frac{r_2'}{s})^2 + (x_1 + x_2')^2]^{1/2}}$$

$$\text{Torque } T_e = \frac{3V_1^2 r_2'/s}{\omega_s} \frac{1}{(r_1 + \frac{r_2'}{s})^2 + (x_1 + x_2')^2} \text{ N - m}$$

**Q.34** What do you mean by transmission line efficiency and regulation? Can it be negative also? (4)

**Ans:**

**Transmission Efficiency:-**

The ratio of receiving end power to the sending end power of a transmission line is known as the transmission efficiency of the line.

$$\% \text{ Transmission Efficiency} = (\text{Receiving end power} / \text{Sending end power}) \times 100;$$

$$= (V_R I_R \cos\phi_R / V_S I_S \cos\phi_S) \times 100;$$

where  $V_R$ ,  $I_R$  and  $\cos\phi_R$  are the receiving end voltage, current and power factor while  $V_S$ ,  $I_S$   $\cos\phi_S$  are the corresponding values at sending end.

**Voltage Regulation :-**

The difference in the voltage at the receiving end of a transmission line between the conditions of no load and full load is called voltage regulation and is expressed as a percentage of the receiving end voltage.

Mathematically,

$$\% \text{ voltage regulation} = (V_S - V_R) / V_R \times 100;$$

$$\% \text{ Voltage regulation is also given by} = (I R \cos \phi_R \pm I X \sin \phi_R) / E_R \times 100;$$

+ for lagging pf

– for leading pf;

When the pf is leading, and the term  $I X \sin \phi_R$  is more than the  $I R \cos\phi_R$ , then the voltage regulation becomes –ve.

**Q.35** With the help of neat sketches explain different types of distribution systems. (10)

**Ans:**

**Different types of distribution systems :-**

**(i) Radial system :**

In this system separate feeders radiate from a single sub station and feed the distributors at one end only. Figure shows a single line diagram of a radial system for a DC distribution where a feeder OC supplies a distributor AB at a point A. Obviously the distributor is fed at one end only i.e. point A in this case.

The radial system is employed only when power generated at low voltage and sub-station is located at the center of the load.

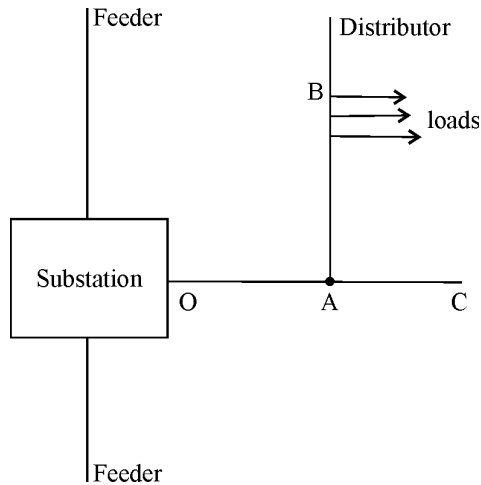

(ii) **Ring main system :-**

In this system the primaries of distribution transformers form a loop. The loop circuit starts from the sub-station bus bars, makes a loop through the area to be served and returns to the sub-station.

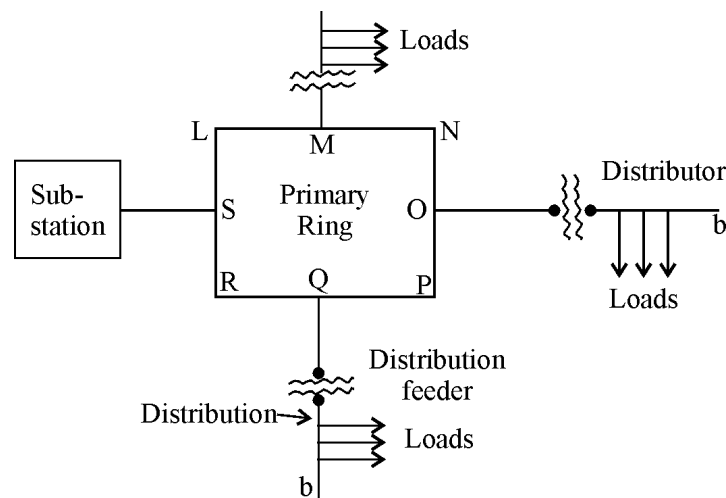

The sub-station supplies to the closed feeder LMOPQRS. The distributors are tapped from different points M, O, and Q of the feeder through distribution transformer. This system has the advantage of continuity of supply and less voltage fluctuations.

(iii) **Inter-connected system :-**

When the feeder ring is energized by two or more than two generating stations or substations it is called inter connected system.

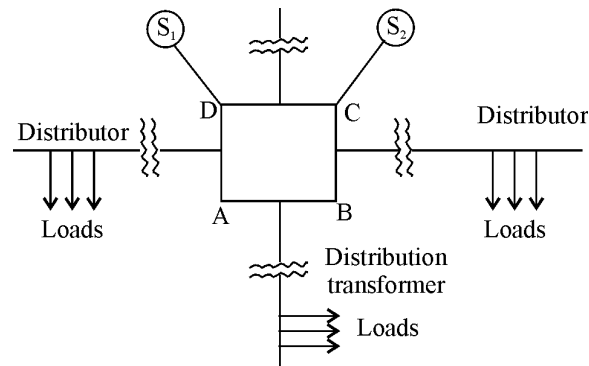

In the above diagram of the inter-connected system the closed feeder ring ABCD is supplied by two sub stations  $S_1$  and  $S_2$  at D and C. Inter connected system has the advantages of increased service reliability and increasing efficiency of the system by reducing reserve power capacity.

**Q.36** Write notes on any **TWO**: -

- (i) Industrial drives and their control.
- (ii) Laying of underground cables.
- (iii) Carrier-current protection and communication.

(7+7)

**Ans:**

**(i) Industrial drive and their control :-**

Any motor with a speed control arrangement can be termed as a drive. The application of these drives for industrial purposes are almost universal since they possess inherent advantages over other forms of conventional drives viz, it's cleaner, more easily controllable and more flexible. Both AC and DC are used for electric drives.

There are two types of drives viz, group drive and individual drive. Each machine having its own driving motor is called individual drive. When a no. of machines are driven through belts from a common shaft, it is called group drive. Selection of the type drive depends on the application to be served.

**Control :-** Mostly DC shunt /series motor and induction motor are used as drive motors in industry.

**(1) Control of DC motors**

- (i) Field control
- (ii) Armature control
- (iii) Ward-Leonard system of speed control
- (iv) Electronic control such as Thyristor control, Chopper control

**(2) Control of Induction motors**

- (i) Frequency method
- (ii) Pole changing method
- (iii) Applying variable voltage to stator
- (iv) Varying rotor copper loss
- (v) Slip speed recovery control

**(ii) Laying of UG cables**

**(a) Direct laying :** This method of laying UG cables is simple and cheap. In this method a trench is dug. The trench is covered with a layer of fine sand and the cable is laid over the sand bed. The sand bed prevents the entry of moisture from the ground and thus protects the cable from decay. After the cable is laid, it is then covered with bricks and other material to protect the cable from mechanical injury.

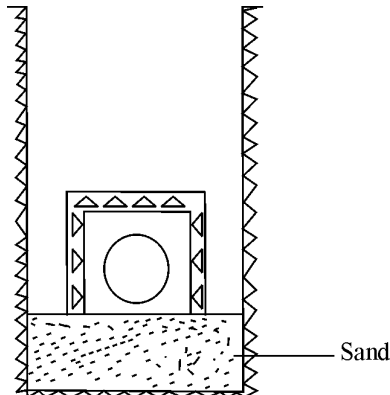

**(b) Draw in system :** In this method, conduit or duct of glazed stone or cast iron or concrete are laid in the ground with manholes at suitable positions. The cables are then pulled into position from manholes. Figure shows section through four way underground duct line. Three of the ducts carry information cables and fourth duct carries relay protection connection, pilot wires. Care must be taken that where the duct line changes the direction, depths, dips and offsets are made with a very long radius or it will be difficult to pull a very large cable between manholes.

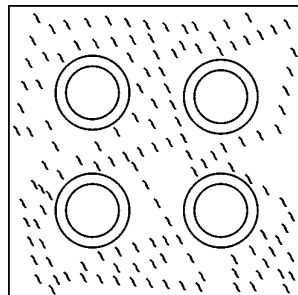



(c) **Solid system** : In this method of laying the cable is laid in open pipes or troughs dug out in earth along the cable route. The troughing is of iron, stone ware, asphalt or treated wood. After the cable is laid in position, the troughing is filled with a bituminous or asphaltic compound and covered. Cables laid in this manner are usually plain lead covered because troughing affords good mechanical protection.

### (iii) Carrier Current Protection and Communication

On long lines carrier pilot relaying is cheap and more reliable than the pilot wire relaying even though it is expensive and complicated than with pilot wire relaying. In this type of protection the phase angle between two ends of the line decides whether the fault is internal or external. When a voltage of positive polarity is impressed on the control circuit, it generates a high frequency o/p between on phase conductor and ground. Each carrier current receiver receives carrier current from its local transmitter as well as from the transmitter at the other end of the line. These signal are then compared for any fault condition and action is taken correspondingly. Traps are used to confine the carrier currents to the protected section so as to avoid interference from other carrier current channels.

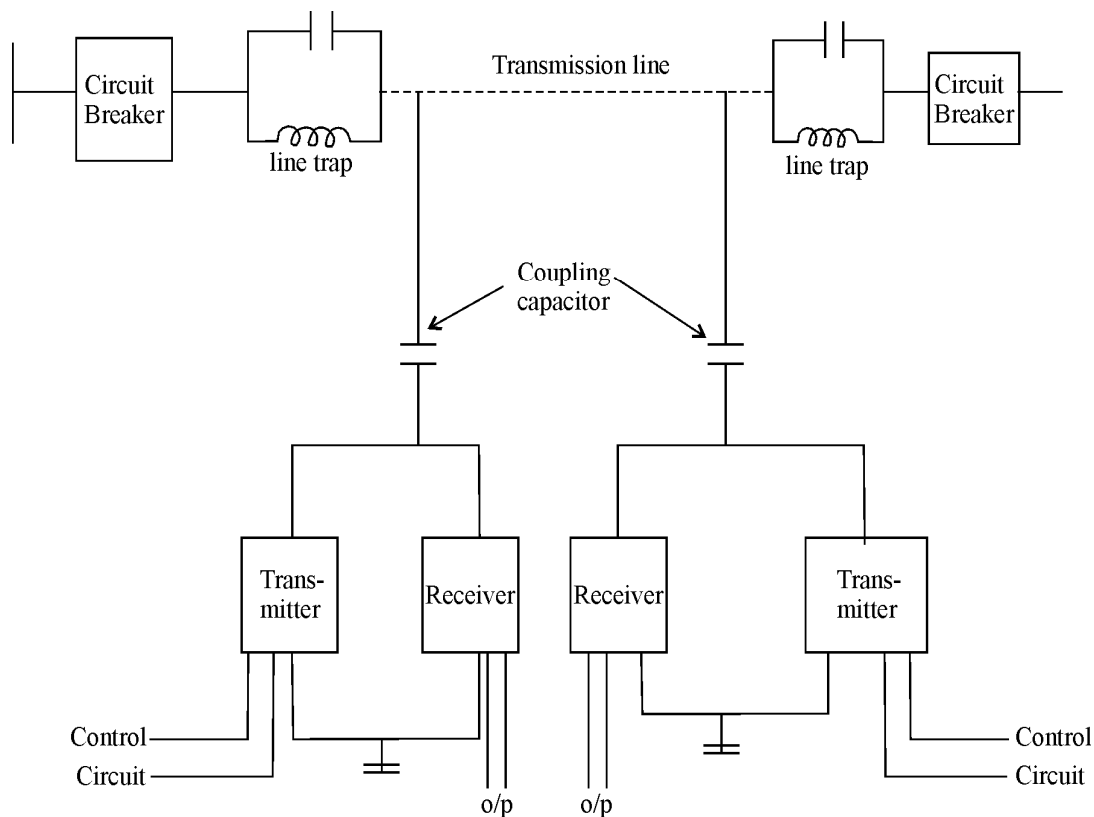

**Q.37** Can a transformer be used to transform direct voltage and direct current? Justify your answer. (5)

**Ans:** The transformer can not be used for dc supply system (dc voltage & current). According to working principle of the transformer, it works on Faraday laws of Electromagnetic Induction. Therefore, induced emf  $e = (-d\Phi/dt)$ . The changing rate of magnetic flux is responsible for e.m.f generation, which opposes the change of magnetic flux, that is indicated by negative sign. But in case of dc supply system (d.c Voltage & Current), there is no change of magnetic flux,  $d\Phi = 0$ , so that induced emf at secondary side of transformer is zero. Therefore, we can not use transformer for dc supply system.

**Q.38** How does a salient-pole rotor differ from a cylindrical rotor in synchronous machines. Where are the salient-pole type of synchronous machines used? (3+3)

**Ans:**

#### Salient Pole Rotor

1. It has large number of projecting (salient) poles having their cores bolted or dovetailed on to a heavy magnetic wheel of cast iron or steel of good magnetic qualities.
2. Such machines are characterized by their large diameter and short axial length.
3. It is used for low and medium speed synchronous machines. (Engine drive generators)

#### Cylindrical Rotor

1. The rotor consists of a smooth solid forged steel cylinder having a number of slots milled out at intervals along the outer periphery (parallel to shaft) for accommodating field coils.
2. These machines are characterized by their small diameter and large axial length.
3. It is used for High speed synchronous machines. (Turbine driven generators)

**Q.39** Explain the effect of 'armature reaction' on the performance of D.C. motor. (8)

**Ans:** Effect of armature reaction

Armature reaction means effect on magnetic field distribution, this works in two ways:

- demagnetize or weaken the main flux
- Cross magnetise or distort the main flux.

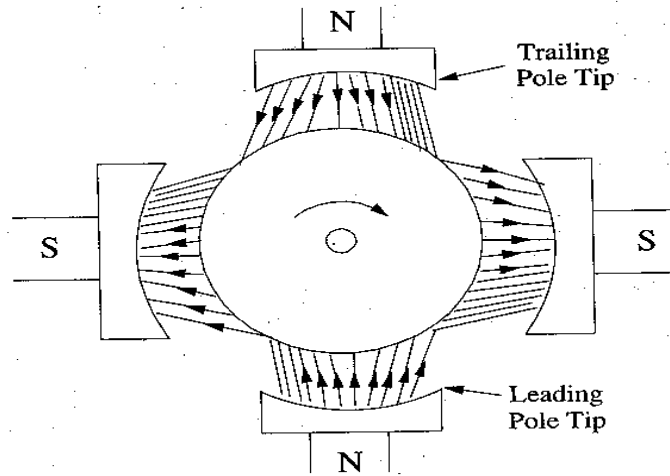

Fig - (i)

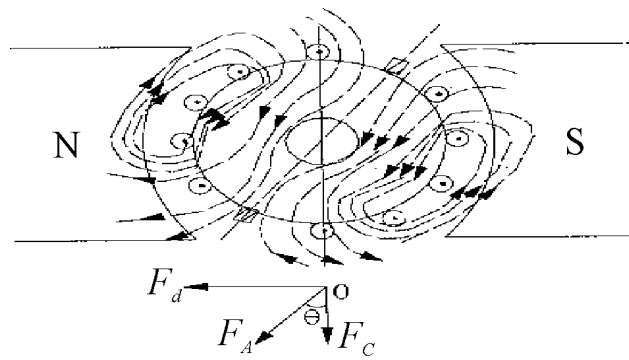

Fig - (ii)

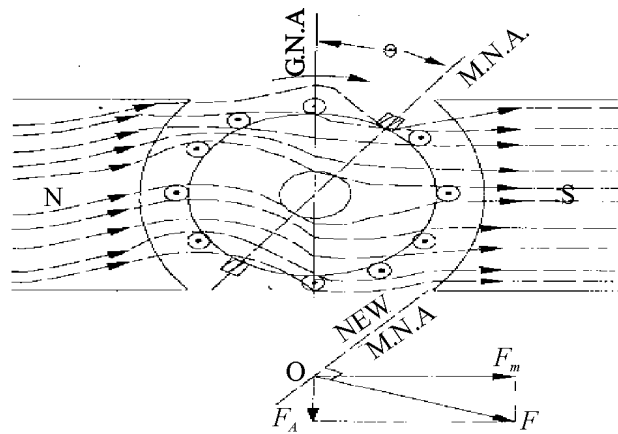

Fig - (iii)

The first effect leads to reduce the speed of dc motor and second to produce sparking at brushes. For armature reaction illustration, two poles have been considered and initially assumed that there is no current in the armature conductors. The assumptions are as under:

- That the flux is distributed symmetrically with respect to polar axis, which is line joining the centres of NS poles.
- The magnetic neutral axis or plane (M.N.A) coincides with the geometrical neutral axis(G.N.A)

The figure (i) shows flux distribution by poles (N&S) without armature current and figure (ii) shows field or flux set up by armature conductors. And figure (iii) shows the resultant flux or (mmf) component 'OF' which is found by vectorally combining  $OF_m$  and  $OF_A$ .

**Q.40** Explain the principle of operation of an induction generator. (4)

**Ans:** Induction Generator Principle:

Induction Generator is a machine similar to a induction motor and driven above synchronous speed. Therefore, this is acting as an ac asynchronous generator. If the machine is run below synchronism, the machine takes in electrical energy and act as induction motor, at synchronism the power component of current becomes zero and changes sign, so that, above synchronism, the machine gives out electrical energy as a generator (when driven by mechanical power)

**Q.41** Write notes on any TWO of the following:-

- (i) Application of transformers.
- (ii) Pulse transformers.
- (iii) Single-phase induction motor.

(2 x 7 = 14)

**Ans:** Application of Transformers:

- To step up the generated voltage for transmission line.
- To step down the transmission voltage to distribution voltage at load centre.
- To transfer power from one circuit to another circuit, used in control and regulation devices.
- To couple the different stages of signal in amplifier circuit (electronic devices)
- Used in communication cable for impedance matching from source to load.

- Used in communication system and digital network as a signal pulse transformer.

(ii) **Pulse transformers:**

The magnetic flux in typical pulse transformer does not change between positive and negative values. The typical pulse Transformer operates in unipolar mode. A fixed dc current can be used to create biasing, a dc magnetic field in the transformer core thereby, forcing the field to cross over the zero line.

CL = LOAD (STORAGE / FILTER) CAPACITOR

Cp = PRIMARY WINDING SELF CAPACITANCE  
& WINDING TO WINDING CAPACITANCE

Cs = SECONDARY WINDING SELF CAPACITANCE

Lm = TRANSFORMER MUTUAL INDUCTANCE

Lkp = PRIMARY LEAKAGE INDUCTANCE

Lks = SECONDARY LEAKAGE INDUCTANCE

Rc = RESISTANCE REPRESENTING CORE LOSS

Rd = DIODE EFFECTIVE RESISTANCE

RL = LOAD RESISTANCE

Rp = PRIMARY WINDING RESISTANCE

Rs = SECONDARY WINDING RESISTANCE

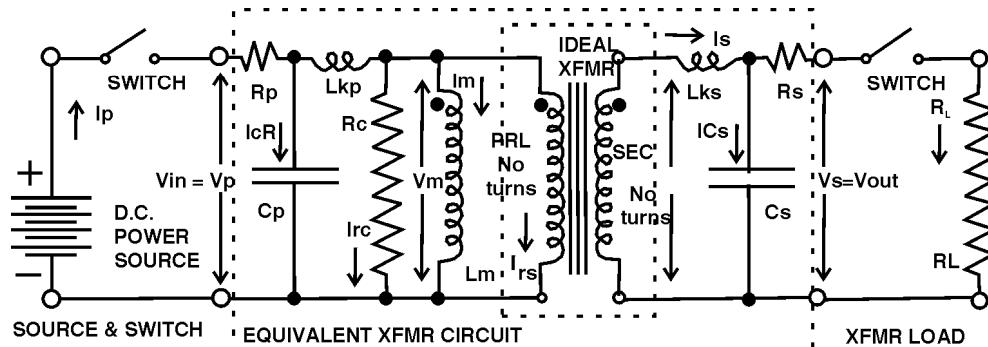

The pulse transformers usually operate at high frequency necessitating use of low cores. The circuit treats parasitic elements, leakage inductance and winding capacitance as lumped circuit elements. But they are actually distributed elements. The pulse transformer design usually seeks to minimize voltage drop, rise time and pulse distortion. Voltage drop declines output pulse voltage over the duration of one pulse. It is caused by the magnetizing current increasing during the time duration of the pulse.

The pulse transformer can be divided into two major types:

- **Power Pulse Transformer** : These are used in precise control of heating element from dc voltage source.
- **Signal Pulse Transformer**: These are used for delivery of signal at output. The transformers deliver pulse like signal or series of pulses. The turns ratio of pulse Transformer can be used to adjust signal amplitude and provide impedance matching between source and load.

Signal pulses Transformer are frequently used in communication systems and digital network.

### (iii) Single Phase Induction Motor

This motor is similar to a 3-phase induction motor except its stator is provided with a single phase winding and a centrifugal switch is used in some types of motors, in order to cut out a winding used only for starting purpose. This motor has distributed stator winding and squirrel cage rotor. When stator is fed from single phase supply, its stator winding produces a flux which is only alternating. This alternating or pulsating flux acting on a stationary squirrel cage rotor cannot produce rotation (only a revolving field can). Therefore, single phase motors are not self-started.

If the rotor of single phase induction motor is initially started by hand or otherwise, in either direction, then immediately a torque arises and motor accelerates to its final speed.

An alternating uniaxial quantity can be represented by two oppsitley rotating vectors of half magnitude. An alternating sinusoidal flux can be represented by two revolving fluxes, each equal to half the value of the alternating flux and each flux is rotating at synchronous speed in opposite direction.

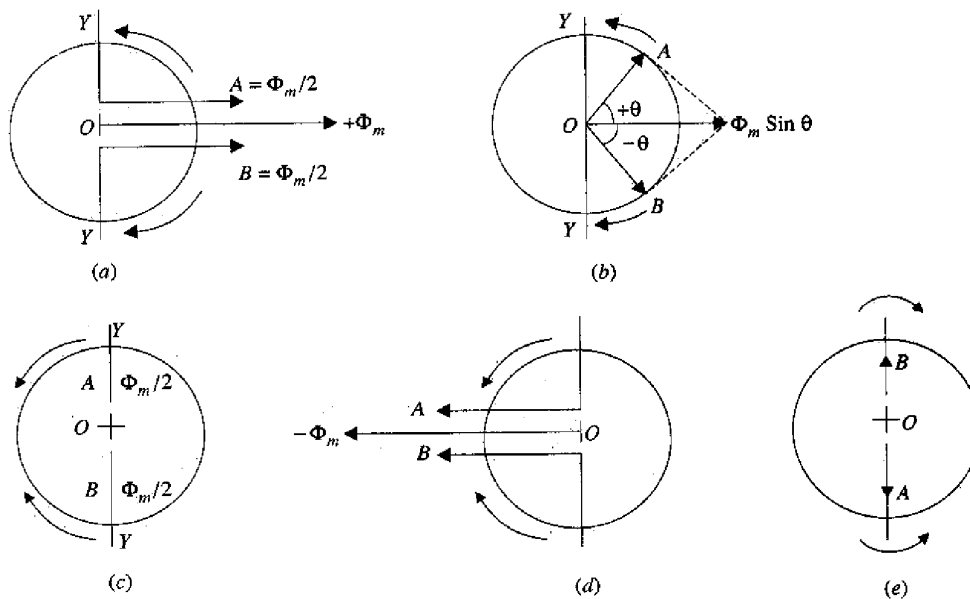

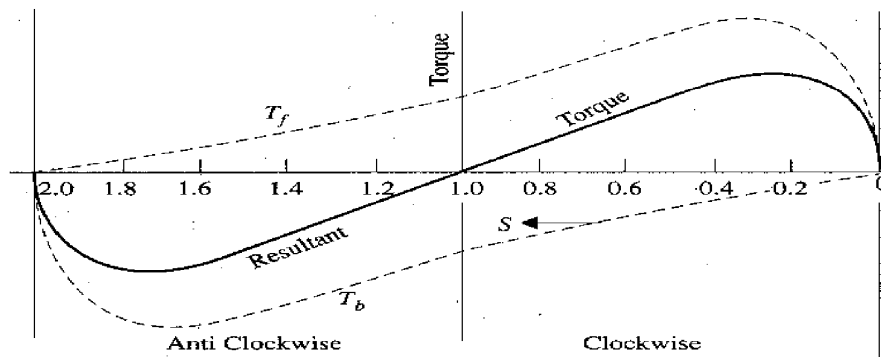
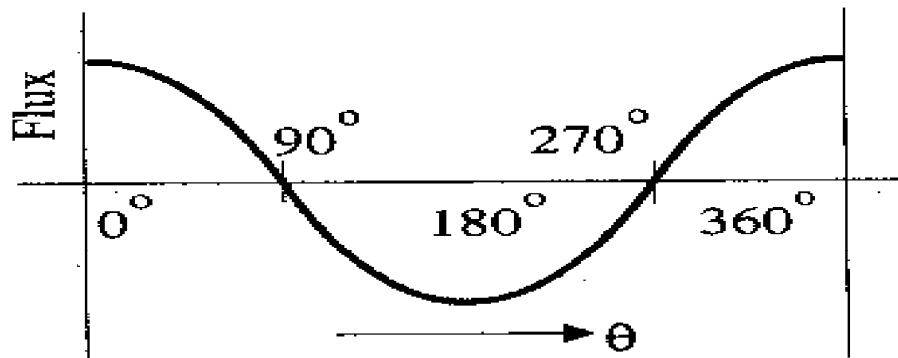

$$\text{Total torque } T = T_f + T_b$$

$T_f$  = forward torque

$T_b$  = backward torque

To make single phase induction motor self starting, it is temporarily converted into a two phase motor during starting period. For this purpose, the stator of a single phase motor is provided with an extra winding known as starting winding. Two windings are spaced at  $90^\circ$  electrically apart and connected in parallel across single phase supply.

These motors are widely useful in home, offices, factories/workshop & in business establishment etc.

**Q.42** Bring-out the advantageous features of the following:

- (i) Gas turbines.
- (ii) Energy Conservation.

(7 x 2 = 14)

**Ans:** (i) Advantageous features of Gas Turbines:

- Very high power-to-weight ratio.

- Smaller in size.
- Moves in one direction only, with less vibrations.
- less moving parts.
- Low operating pressures.
- High operation speeds.
- Low lubricating oil cost and consumption.

(ii) **Energy conservation advantageous features.**

- It saves, the need of fuel imports for many power plants.
- It minimises CO<sub>2</sub> and environmental pollution.
- It helps in global warming problem solution.
- Less air pollution.
- Fewer power plants and liquid natural gas ports are needed.
- Less need to secure oil and natural gas overseas.

**Q.43(a)** Why are different levels of voltages used for generation, transmission and distribution of electric power? (7)

**(b)** What are the essential differences between H.V. and L.V. switchgears? (7)

**Ans:** (a) Different Levels Of Voltages For Generation, Transmission And Distribution:

- The generation voltage is upto 30 KV AC rms (line to line).
- The long distance high power transmission is by EHVAC lines 220 kV, 400 kV & 760 kV Ac. In special cases, HVDC line is preferred. The rated voltages of HVDC lines are  $\pm 250$  kV,  $\pm 400$  kV,  $\pm 500$  kV &  $\pm 600$  kV.
- The backbone transmission system is done by EHV AC transmission lines (400 kV AC & 200 kV AC).
- Distribution is at lower AC voltage between 132 kV AC and 3.3 kV AC.
- Utilization is at the low voltages upto 1kV and medium voltage upto 11 kV.
- The industrial substations receive power at distribution voltage such as 3.3 kV and step down it to 440 V AC. Larger industries receive power at 132 kV and internal distribution at 3.3 kV to 440 volt AC.



**H.V. switch gears:**

- **Circuit breaker:** Switching during normal and abnormal conditions , interrupt the fault currents.
- **Isolators:** It is disconnecting switch to disconnect the system from line parts under no load condition.
- **Earth switch:** This is used to discharge the voltage on the lines to earth after disconnecting them.
- **Surge arrester:** This is used to divert the high voltage surge to earth and maintaining continuity during normal voltage.
- **Current Transformer :** To step down the current for measurement, protection and control purposes.
- **Potential Transformer :** To step down the voltage for the purpose of protection, measurement and control.

**L.V. Switchgears:**

- **MCBs (Miniature Circuit Breakers):** Switching OFF during abnormal conditions to interrupt the fault current.
- **Fuses:** A short length wire having low melting point, connected in series with circuit. In the event of fault, the circuit current rises abruptly and fuse wire melts to interrupt the circuit.
- **Switches:** these are used to ON /OFF the power of a circuit. These are used in power/ control circuits. The switches are specified as per voltage rating, current rating, number of poles, duty cycle and fault interruption capacity.

**Q.44** Classify the different types of secondary cells and describe the operating characteristics of any one of them. (14)

**Ans:** Classification of secondary Cells.

Secondary cell is one in which chemical reaction is reversible. Therefore, secondary cell can be recharged after use. These cells are also known as storage cells and accumulators. These cells are classified as follows:

- lead acid cells.
- alkaline cells.

Lead acid cells are used in electric substation for emergency lighting, to provide d.c supply for various relays, to provide d.c supply for telephone exchange, communication equipments, automobiles and inverters.

Ni – cadmium (Alkaline) cells of higher capacity and lower weight are preferred. These cells have longer life, lower running cost and less maintenance. The disadvantage of this cell is its higher initial cost. These cells are useful for aircraft, emergency power application, industrial power supply, portable tools etc.

Operating Characteristics of Lead Acid Cells

i.	Anode	Lead peroxide (PbO <sub>2</sub> )
ii.	Cathode	Spongy lead (Pb)
iii.	Electrolyte	Solution of Sulphuric acid
iv.	Voltage per cell	2 Volts
v.	Specific gravity of electrolyte	1.230
vi.	Life	short life
vii.	Cost	cheap
viii.	Overcharging	life is severely affected
ix.	Efficiency (Ah)	90-95%
x.	Internal resistance	low

**Q.45** Why are solid-state controllers preferred over conventional controllers? Give examples of their applications and explain their features. (14)

**Ans:** **Solid State controllers Vs Conventional Controllers:**

Primarily motor control circuit of conventional type consists of switches, fuses, relays, contactors and associating cabling. This type of conventional contactor control system become bulky if implemented for complicated logic. The trouble shooting also becomes difficult and time consuming.

On the other side, solid state controller made up by electronic components / devices are used to implement such schemes in place of conventional contactor control which are efficient, reliable and need less time for trouble shooting.

A PLC (Programmable Logic Controller) is known as solid state controller. The main difference between relay logic controller and computer based solid state controller (PLC) are:

- All input, output variables are in binary form
- In relay logic programming whenever any event sequence is to be changed, rewiring of panel is necessary which was cumbersome. In computer based system, it is easy to change program through software.
- Solid state devices can be easily controlled by computer.

Therefore, Programmable Logic Controller (PLCs) are compact electronics devices that allow any process logic to be implemented by programming of PLC. It avoids lot of external control wiring. The PLC can be programmed according to user's need and the logic can be changed as per requirement as and when it is required.

**The PLC Architecture:**

The PLC consists of :

- CPU (Central processing Unit)
- Memory
- Power supply
- Input Circuit
- Output Circuit

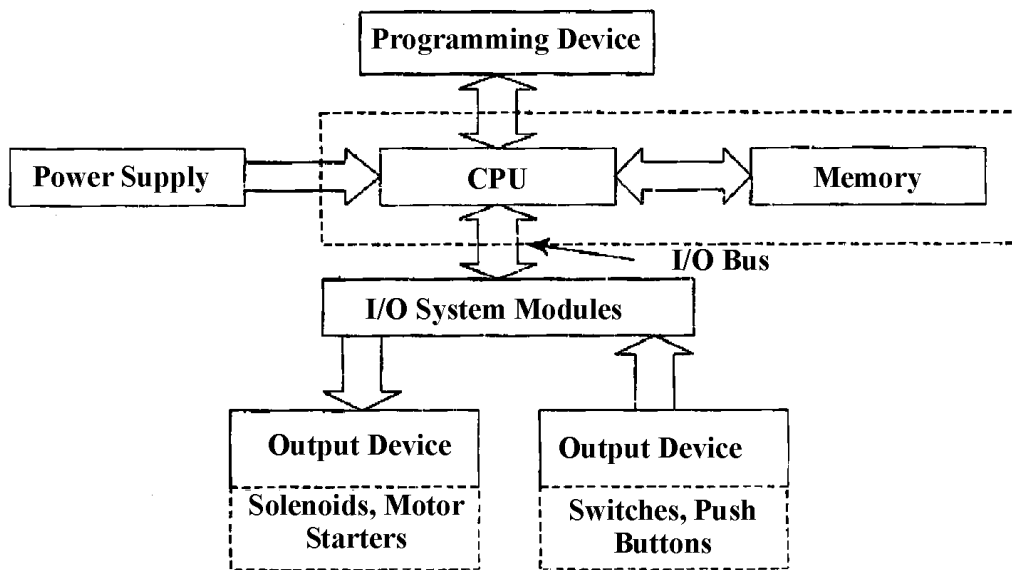

**PLC operation:** A PLC work is based on continuous scanning program. It has three steps

- Check input status.
- Execute program.
- Update output status.

**Q.46** Write notes on any **TWO** of the following: -

- (i) Hysteresis motor.
- (ii) HVDC transmission.
- (iii) Button cells for low power applications.

(7+7)

**Ans: (i) Hysteresis Motor:**

This is a single phase special purpose motor. Its hysteresis torque remains constant from locked rotor to synchronous speed. A hysteresis motor is able to synchronise at any load. The stator of hysteresis motor has two windings which remain connected to supply continuously in starting as well as during running of motor.

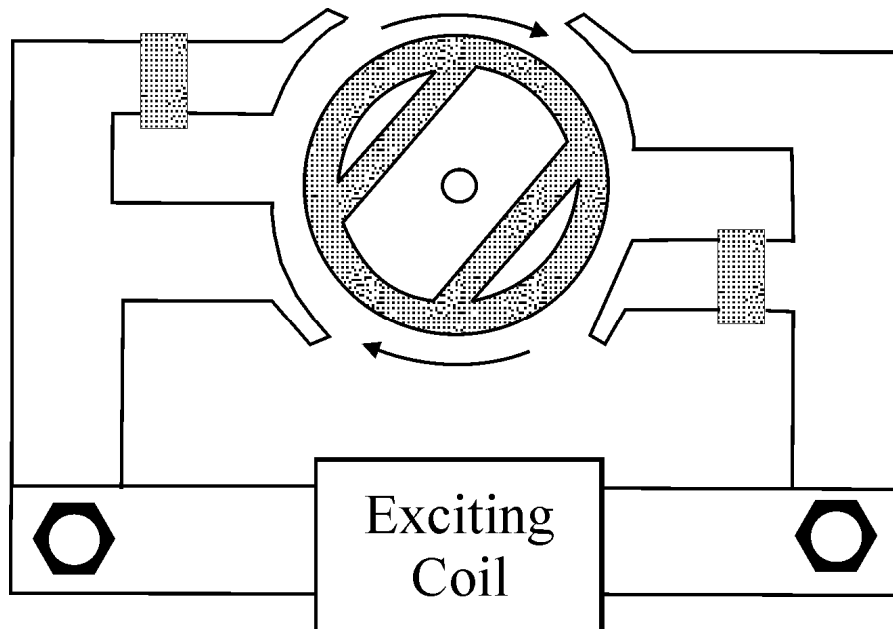

The rotor is made by a smooth chrome steel cylinder having high retentivity so that the hysteresis loss is high. It has no winding. The rotor poles are magnetically locked up with revolving stator poles of opposite polarity. However rotor poles lag behind the stator poles by an angle  $\alpha$ . The mechanical power developed in a hysteresis motor :

$$P_m = P_h (1-s)/s \quad \text{where } P_m = \text{Mechanical power developed}$$

$$P_h = \text{Hysteresis loss in rotor}$$

$$T_h = \text{Hysteresis torque}$$

$$\text{and } T_h = 9.55 P_m / N_s$$

These motors are useful for driving tape- decks, turn table and other precision audio equipments. The commercial motors have two poles, they run at 3,000 rpm at 50 Hz , single phase supply.

**(ii) HVDC Transmission**

The HVDC transmission is selected as an alternative to extra high voltage AC transmission system due to following reasons:

- For long distance high power transmission .
- For interconnection (Tie- lines) between two AC systems having their own load frequency control
- For back to back asynchronous tie sub-stations.
- For underground or submarine –cable power transmission over long distance at high voltage.

In HVDC link, AC power is converted by power electronic device at one end. The energy is transmitted in HVDC form to the other end. At the other end the DC power is inverted and fed into receiving A.C system. HVDC transmission system has a HVDC converter substation at each end and HVDC transmission line in between.

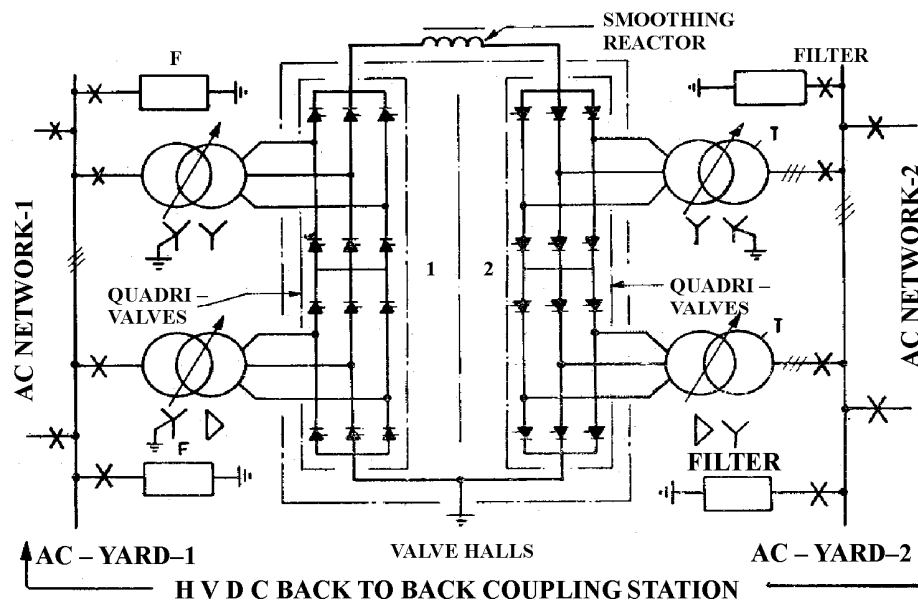

### (iii) Button Cells for low power applications.

These cells are compact in size and have long life. Examples of button cells are Mercury oxide and silver oxide cells. Mercury oxide cells have Mercury cathode and zinc as an anode. The watch battery are usually single cell with nominal voltage between 1.5V and 3.0V

The specific feature of button cells:

- **Common anode material** : Zinc, Lithium
- **Common cathode material** : Magnese oxide, silver oxide, carbon monoflouride, copper oxide.

- **Electrolyte** : Alkali or organic, alkali required for zinc cathode and organic for lithium cathode.
- **Nominal voltage** : for Zinc cathode = 1.5V to 1.65V ; for lithium cathode = 1.5 V to 3.0V
- **End point Voltage** : for Zinc cathode = 1.0V to 1.4V ; for lithium cathode = 1.2 V to 2.0V

**Applications** : used in quartz watches, calculator, PDA, Hearing aids, etc.

**Q.47** Where are synchronous motors used? (4)

**Ans:** **Synchronous motor applications**

- (i) Power factor correction
- (ii) Constant speed, constant load drives
- (iii) Voltage regulation

Over excited synchronous motors having leading power factor are widely used for improving power factor of those systems which employ a large number of induction motors and other devices having lagging power factor such as welders and fluorescent lights etc.

In constant speed applications, synchronous motors are well suited due to their high efficiency and high speed, such as centrifugal pumps, belt driven reciprocating compressors, blowers, line shafts, rubber and paper mill etc.

Voltage in long transmission lines varies greatly at the end when large inductive load are present and when inductive load disconnected suddenly, the voltage tends to rise considerably above its normal value because of line capacitance. Therefore, by installing a synchronous motor with field regulator, the voltage rise can be controlled.

**Q.48** How is the speed of a DC shunt motor controlled? (5)

**Ans:** **Speed control of D.C Motors (Shunt type)**

D.C shunt motor speed can be controlled by the following methods:

- i. Flux control method.
- ii. Armature control method.
- iii. Voltage control method.

$N \propto 1/\Phi$  ; By decreasing flux, speed can be increased and vice – versa. The flux of DC motor can be changed by changing the field current with the help of shunt field rheostat.

$N \propto (V - I_a R_a)$ , The speed / armature current characteristics show that greater the resistance in armature circuit , greater fall in speed.

Shunt field of motor is connected permanently to a fixed exciting voltage, but armature is supplied with different voltages by connecting it across one of the several different voltage by means of suitable switchgear.

**Q.49** Why are starters used for starting 3-phase induction motors? (4)

**Ans: Starters for three phase induction motors:**

For starting of 3 - $\Phi$  induction motor, we need Y- $\Delta$  (star – delta) starter. These starters are useful for safe running of induction motor by applying  $1/\sqrt{3}$  times of voltage in Y- mode for safety of induction motor. When motor gets 80% of speed we apply full voltage  $V_{ph}=V_L$  in  $\Delta$  mode; during this time sufficient back e.m.f is developed to limit the input current.

**Q.50** Write notes on any TWO of the following:-

- (i) Parallel operation of transformers.
- (ii) Speed control of induction motors.
- (iii) Applications of induction machines.

(2 x 7 = 14)

**Ans:**

**(i) Parallel operation of transformers :**

Certain conditions must be satisfied in order to avoid any local circulating currents and to ensure that the transformers share the common load in proportion to their kVA ratings, The conditions are :

- The Primary winding of the transformers should be suitable for the supply system voltage & frequency.
- The transformer should be properly connected with regard to polarity.
- The voltage rating of both primaries & secondaries should be identical (same turn ratio)
- Percentage impedances should be equal in magnitude and have the same X/R ratio in order to avoid circulating currents and operation at different Power factors.
- With transformers having different kVA ratings, the equivalent impedances should be inversely proportional to the individual kVA ratings, if circulating currents are to be avoided

In case of 3 phase transformers' parallel operation, the following conditions are also added with the above conditions.

- The voltage ratio must refer to terminal voltage of primary and secondary.

- The phase displacement between primary & secondary voltages must be the same for all transformers, which are to be connected for parallel operation.
- The Phase sequence must be the same.
- All 3- $\Phi$  transformers must have same construction either core or shell.

**(ii) Speed control of induction motors**

The speed control of induction motor is obtained by various methods :

- i. Frequency variation.
- ii. Pole changing.
- iii. Changing motor circuit resistance.

A slip ring (wound) motor is an adjustable speed motor. The rotor winding terminals are connected to slip rings. A 3- $\Phi$  star connected rheostat is provided separately with motor. By changing the resistance in rotor circuit, the torque speed characteristics of machine can be changed. The Speed & Torque can be changed as:

$$T \propto r_2 / s \text{ and Slip 's' } \propto r_2$$

By increasing rotor resistance, The torque increases and slip 's' increases, Therefore, speed decrease as:

$$T \propto 1/N$$

The speed reduces in slip ring induction motor through rheostat control; and this can be obtained only if the motor is loaded under no load condition. The no-load speed changes are very little with the variation in the load resistance.

**(iii) Applications of Induction Motors :** The squirrel cage induction motor with single or double pole changing windings are available as follows:

<u>CLASS</u>	<u>APPLICATIONS</u>
(1) Variable torque, power output $\propto N^2$ .	Fans, centrifugal pumps.
(2) Constant –torque power output $\propto N$ .	Conveyors, stokers, reciprocating Compressors, printing presses.
(3) Inverse torque power output rating constant.	Machine Tools, lathes, boring mills, drill, planers,.

The Multi-speed motors are of slip ring type used for hoist, conveyor and elevator.

**Q.51** Highlight the role of following in the generation of power

- (i) Cogeneration.
- (ii) Diesel generator.

(7 x 2 = 14)



**Ans: Co-generation**

The interconnection of hydro and thermal power generation plant or reuse of waste product of first generator as a fuel of second generator or other machine :

The large power system comprising several power stations load centres interconnected to form a single grid operation of such a grid is controlled from a load centre or load dispatch centre. The national load control centre is linked with various regional despatching stations. The regional load centres send commands from power stations to control room periodically by telemetric data transmission system.

The automatic load frequency control in the control system of generator turbine governor basically aim to maintain a constant frequency/speed as a primary control. But setting of the governor for turbine is changed according to instruction of regional control centres. Therefore, The input of turbine from governor gets automatically adjusted by primary load frequency control and frequency is maintained. The governor setting is determined by economy load dispatch instructions from regional load control centres. The total load cogeneration control is achieved by:

- Load control centre.
- Telemetry or telecontrol equipment.
- Power station control room.

(ii) **Diesel Generator:** These are used in medium power plants upto 25MW for industrial and marine applications. The transportable diesel generator sets are for remote location, and small power plants for small lawns /farms etc.

Generators are usually gear driven to speeds of 1000 to 1500 rpm for 50 Hz. Diesel engines have a speed range of 1500 rpm to 2250 rpm (higher speed for gas turbine driven set)

The critical speed and torsional or natural frequencies are checked for diesel generator set to avoid resonance. Brushless excitation is commonly used. The diesel generators are mounted on same bed plate of prime mover.

**Q.52(a)** Explain the functions and basic requirements of a protective relay. (7)

(b) Compare the merits and demerits of overhead lines with an underground distribution system. (7)

**Ans: (a) Functions & basic requirements of a protective relay :**

**Functions:**

The protective relaying senses the abnormal conditions as a part of the power system and gives an alarm or isolate that part from the healthy system. The relays are compact, self-

contained devices, which respond to abnormal conditions. Whenever abnormal conditions occur, the relay close its contacts. Thereby trip circuit of the circuit breaker is closed and circuit breaker will open. So that, the faulty part will be disconnected from the supply.

### **Basic requirements**

- **Selectivity, discrimination:** The protective relaying should select the faulty part of the system and should isolate, as far as possible only faulty part from the remaining healthy system.
- **Speed, Time:** It is the time between fault instant and closing of relay. A rapid contact fault cleaning i.e. 0.07 second with 60 kA rms value of current, has no damage to the system but if it is 7 sec, the bus bar will destroy complete. Therefore, relay time must be minimum as much as possible (i.e. in millisecond.)

**Fault clearing time** : Relay time + Breaker time

- **Sensitivity, power consumption:** It refer to the smallest value of actuating quantity at which protection starts operating in relation with the minimum value of fault current in the protection zone

$$\text{Sensitivity factor 'K}_s\text{' = } I_s / I_o = \frac{\text{Minimum short circuit current}}{\text{Minimum operating current in protection.}}$$

**Stability** : A quality of protective system by the virtue of which , the protective system remains operating and stable under certain specified conditions such as system disturbances, through faults, transient etc.

**Reliability** : The protective relaying should not fail to operate in the event of faults in protected zone. The reliability of protective systems depends on diverse aspects such as protective gear manufactures, Electricity Boards & Associates.

**Adequateness** :The adequateness of protection is judged by considering following aspects:

- Rating of protecting machines.
- Location of protecting machines.
- Probability of abnormal condition due to internal and external causes.
- Cost of machine, importance.
- Continuity of supply as affected by failure of machine.

(b)

	<u>Overhead power transmission lines</u>	<u>Under ground Power cable</u>
(A) Merit	1. Easy maintenance & Repair 2. Low cost of installation 3. Mostly used in transmission system due to effective voltage upto 400 kV 4. Less skilled staff is required.	1. Less disturbances for other system 2. system looks neat and beautiful 3. Mostly used in distribution system . (Medium and low voltages upto 11kW) 4. Less lightening thunder effect
(B) De-Merits	1. Chances of frequent failure due disturbance from other system. 2 less safe 3 Lightning protection is required. 4. Chances of tapping or theft more	1. High initial cost 2. High maintenance and repair cost 3. Problem of charging current in HV transmission. 4. Highly skilled staff is required.

**Q.53** (a) Explain the working of a welding machine. (7)

(b) What is inductive interference? How is it caused and what steps are necessary to reduce its effect? (7)

**Ans: (a) Working of a welding machine:**

A welding process is required to join two metal parts by heating them to melting point. Electrical welding is used for joining of fabricating structures, machinery parts, pipes, bus bars, bridges, ships railway bogies etc.

Electrical welding has two distinct types:

- Resistance welding : In resistance welding the current is passed through the joint to be welded and the heat is caused by  $I^2 R$  losses in the joint, melting of metal and subsequent welding under pressure between faces to be welded.

- Arc welding : The heat is produced by the arc struck between the welding electrode and the metal to be welded. Pressure is not applied between faces to be welded.

(b) Inductive interference:

Inductive interference depends upon gradient of voltage at surface of conductor or corona. The inductive reactance is affected from conductor attenuation at 1000 KHz and varies from 0.3 to 0.9 dB/mtr.

**Q.54** Identify the motor being used in the ceiling fan and explain the method of its control. (14)

**Ans: Motor used in ceiling fan:**

Single phase induction motor is used for ceiling fan; this motor is more or less similar to polyphase induction motor, except that

- (i) its stator is provided with a single phase winding
- (ii) Centrifugal switch is used in some types of motors in order to cut out a winding used only for starting purposes; it has distributed stator winding and squirrel cage rotor.

When single phase supply is fed, its stator winding produces a flux (or field) which is only alternating i.e: one which alternates along one space axis only. It is not a synchronously revolving (or rotating flux, as in the case of a two or three phase stator winding fed from 2 or 3 phase supply). Now, an alternating or pulsating flux acting on stationary squirrel cage rotor can not produce rotation (only revolving flux can). Therefore, single phase is not self-starting. To make single phase induction motor self starting the following method is adopted.

- Split phase motor.
- Capacitor start induction run motor.

Split phase motor:

Split Phase method: In this method, phase is split by introducing a resistance and a switch in starting winding and both windings are connected in parallel with supply.

Capacitor – Start induction run motor:

The necessary phase difference between  $I_s$  and  $I_m$  is produced by connecting a capacitor in series with starting winding. The capacitor is designed for short duty service. When motor reaches about 75% of full speed, the centrifugal switch 'S' is open and cuts out both the starting winding and capacitor from supply, thus leaving only running winding across the line.

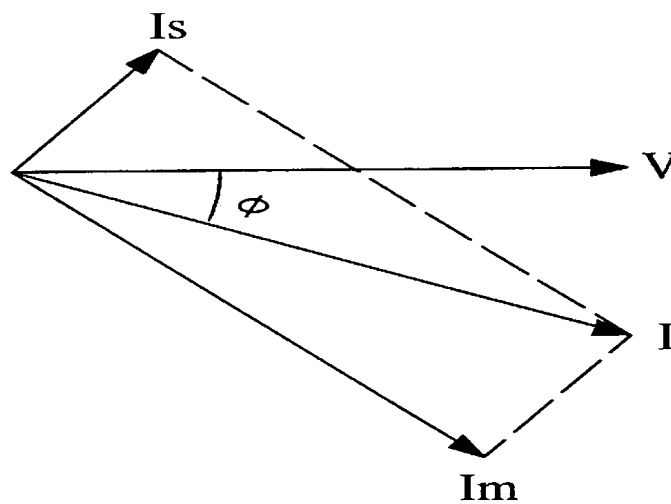
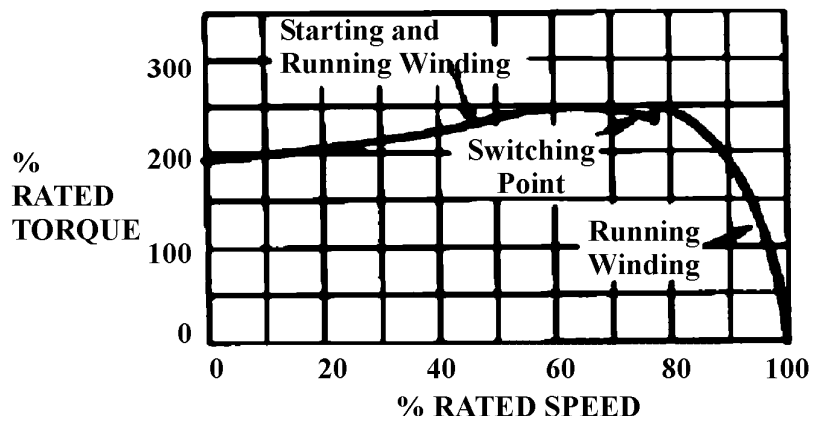
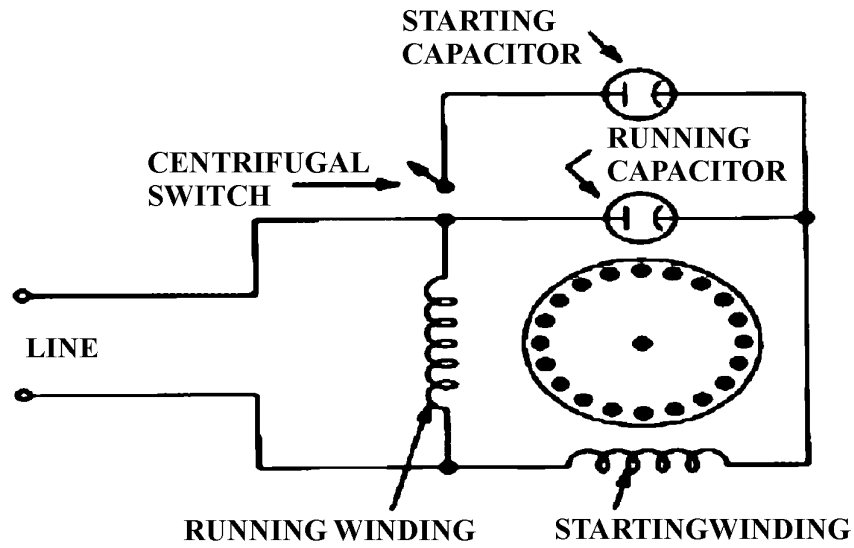

**Q.55** Write short notes on any TWO :-

- (iv) A.C. tachometer.
- (ii) Energy conservation.
- (iii) Carrier current protection

2 x 7 = 14

**Ans:**

i. **AC Tachometer:**

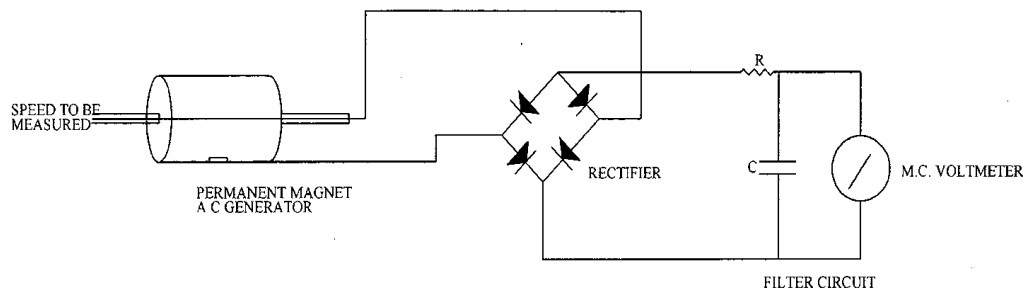

A tachometer generator has rotating magnet, which may be permanent magnet or electromagnet. The coil is wound on the stator and therefore the problem associated with commutator is absent. The rotation of magnet causes an emf to be induced in stator. The amplitude and frequency of this e.m.f are both proportional to the speed of rotation, then either amplitude or frequency of voltage may be used as a measure of rotational speed. When amplitude of induced voltage is used as a measure of speed, the above circuit is used. So that, output voltage of AC tachometer generator is rectified and is measured with a PMMC instrument.

(ii) **Energy conservation:** The energy conservation in a electrical system means efficient use of energy and to minimize the losses of electrical / mech energy in a system to maintain minimum requirement of fuel for power generation and to maintain ecological balance. This can be achieved by following ways.-

- Improving power factor.
- Minimization of reactive loads.
- Optimize / replace electrical control circuit by solid state control circuit.
- Use single unit of electric drive system in split of multiple units.
- Effective periodic maintenance.

- (iii) **The carrier current protection:** The carrier current protection scheme is used for protection of transmission lines. The information about short circuit/earth fault of the power transmission line is conveyed through carrier communication link. The carrier current of frequency range 30 to 200 KHz or 80 to 500 KHz and received through the transmission lines for the purpose of protection. In this system, each end of the line is provided with identical carrier current equipment consisting of a transmitter, receiver, line tuning unit, master oscillator, power amplifier etc.

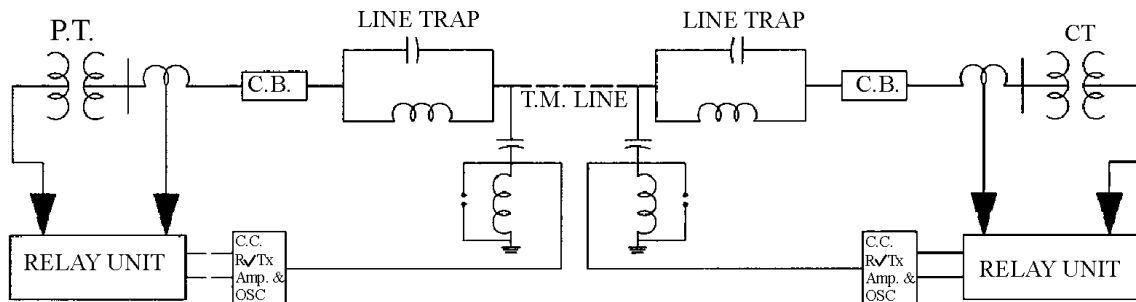

**Q.56** How are the power angle characteristics of synchronous machine obtained. (8)

**Ans:** Power angle characteristics of a synchronous machine :

The power transferred by a synchronous machine

$$P = (VE/X) \sin\delta$$

Where;

P = Power

$\delta$  = Power angle between vector V & E

V = Terminal voltage

E = Induced e.m.f.

An active power generated by a synchronous generator or consumed by synchronous motor is given by following equation:

$$P = \pm V_i E_{f-} \sin\delta / X_S$$

$\delta$  is considered positive for generator mode and negative for motor mode.

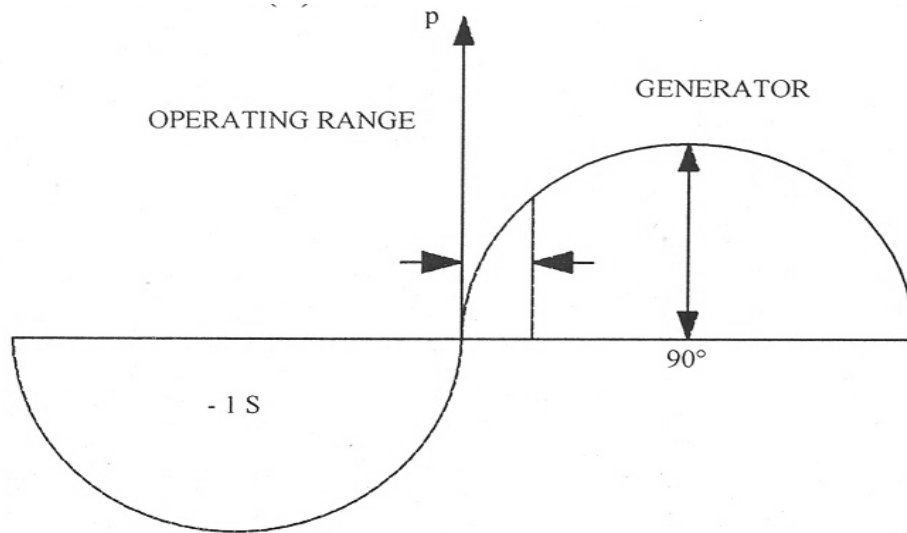

The power output of a synchronous machine can be changed only by changing its power output. Change in excitation does not change in power output. The change in excitation will give only change in e.m.f and negative power supplied by the machine.

**Q.57** How is a DC motor started? (8)

**Ans:**

**D.C Motor Starting**

$$I_a = (V - E_b) / R_a$$

Where  $I_a$  = Armature current in amperes

$V$  = Terminal voltage in volts

$E_b$  = Back emf in volts.

$R_a$  = Armature resistance in ohms.



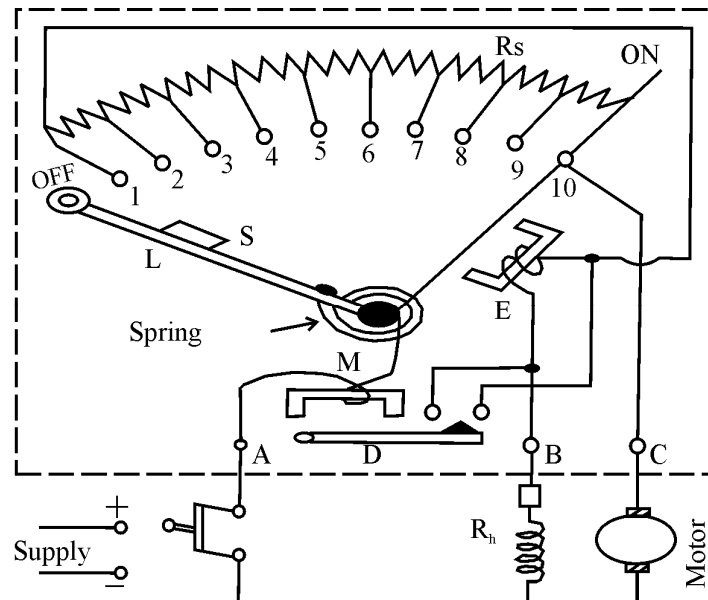

When motor is at rest, no back emf will develop in armature. Now, if full supply voltage is applied to stationary armature, it will draw very large current because armature resistance is relatively very small.

$$\therefore I_a = (V/R_a) ; E_b = 0$$

This excessive current is large and this will damage commutator, brushes etc. To avoid this situation, a resistance is introduced in series with the armature for short duration with the help of starter, which limit the starting current to safe value.

The starting resistance is gradually cut off and motor gets full speed with back e.m.f under safe limit

$$\text{Now } I_a = (V - E_b) / R_a$$

However, very small motor can be started from rest by connecting directly to supply. These motors have relatively large armature resistance than larger motors. These small motors also have low value of inertia.

**Q.58** Describe Rotating Magnetic Field. (8)

**Ans:**

**Rotating magnetic field:**

When stationary coils are supplied with 3 phase supply, a uniform rotating magnetic field of constant value is produced. The flux due to current flowing in each phase winding is assumed sinusoidal and is represented in figure (b). The direction of fluxes are shown in Fig. (c). Let maximum value of flux due to any one of the 3 phases be

$\Phi_m$ . The resultant flux  $\Phi_r$  at any instant is given by the vector sum of the 3 individual fluxes,  $\Phi_1, \Phi_2, \Phi_3$  due to 3 phases

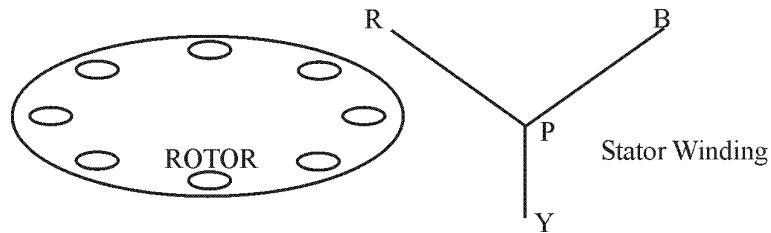

Fig. (a)

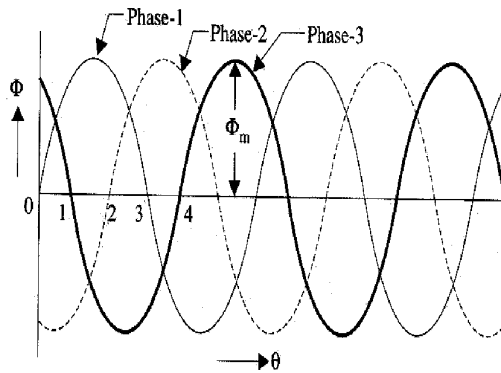

Fig. (b)

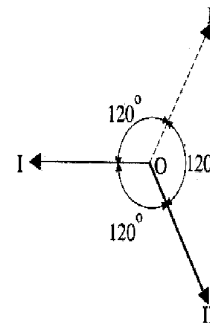

Fig. (c)

Calculation of  $\phi_r$  :

(i) When  $\theta = 0^\circ$  corresponding to point 'O' in Fig (b)

$$\text{Here, } \phi_1 = 0 ; \phi_2 = -\sqrt{3}/2 \phi_m ; \phi_3 = \sqrt{3}/2 \phi_m$$

$$\therefore \phi_r = 2 \times \sqrt{3}/2 \phi_m \times \cos 60/2 = \sqrt{3} \phi_m \times \cos 30$$

$$\phi_r = \sqrt{3} \phi_m \times \sqrt{3}/2 = 3/2 \phi_m = \mathbf{1.5 \phi_m}$$

Similarly at  $\theta = 60^\circ$

$$\phi_1 = \sqrt{3}/2 \phi_m$$

$$\phi_2 = -\sqrt{3}/2 \phi_m$$

$$\phi_3 = 0$$

$$\therefore \phi_r = \mathbf{3/2 \phi_m}$$

And  $\theta = 120^\circ$

$$\phi_1 = \sqrt{3}/2 \phi_m, \phi_2 = 0, \phi_3 = -\sqrt{3}/2 \phi_m$$

Mathematical proof :

$$\phi_1 = \phi_m (\cos 0^\circ + j \sin 0^\circ) \sin \omega t$$

$$\phi_2 = \phi_m (\cos 240^\circ + j \sin 240^\circ) \sin (\omega t - 120^\circ)$$

$$\phi_3 = \phi_m (\cos 120^\circ + j \sin 120^\circ) \sin (\omega t - 240^\circ)$$

Adding above equations , we get

$$\phi_r = 3/2 \phi_m (\sin \omega t + j \cos \omega t) = 3/2 \phi_m (90 - \omega t)$$

Therefore, resultant flux is of constant magnitude and does not change with time t.

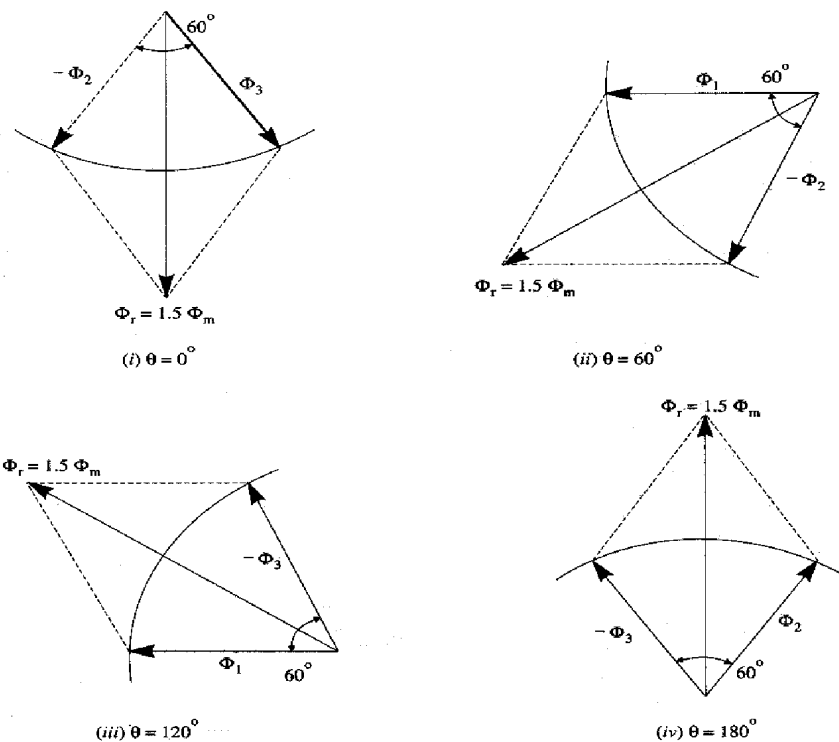

**Q.59** Derive the hysteresis torque expression of the hysteresis motor. (8)

**Ans:** Hysteresis torque expression of the hysteresis motor:

Usually, the shaded pole principle is employed for hysteresis motor. The rotor of this motor is smooth, having high retentivity, so that, hysteresis loss is high. It has no winding, the rotor poles magnetically locked up with the revolving stator poles of

opposite polarity. However, rotor poles always lag behind stator poles by a small angle ' $\alpha$ ' and the rotor revolves synchronously.

The mechanical power developed by rotor is given by

$$P_m = P_h (1-S) / S$$

$P_m$  = Mech power developed

$P_h$  = Hysteresis loss in rotor and hysteresis torque

$$T_h = (9.55 P_m) / N_s$$

$$2\pi N_s T_{sh} / 60 = (E_b I_a - \text{losses}) = \text{out power}$$

$$P_m = (E_b I_a - \text{losses})$$

$$\begin{aligned} \therefore T_{sh} &= P_m / (2\pi N_s / 60) \\ &= (60/2\pi) \cdot (P_m / N_s) \\ &= (9.55 P_m / N_s) \end{aligned}$$

This hysteresis torque is solely dependent on the area of rotor's hysteresis loop.

**Q.60** Write short note about following:-

- (i) Power System structure with diagram. (8)
- (ii) Wave energy. (4)
- (iii) Ocean thermal energy. (4)

**Ans:** Power System structure with diagram:

Electrical power system can be divided into following regions :

- Generating stations
- Transmission systems
- Receiving station
- Distribution system
- Load points

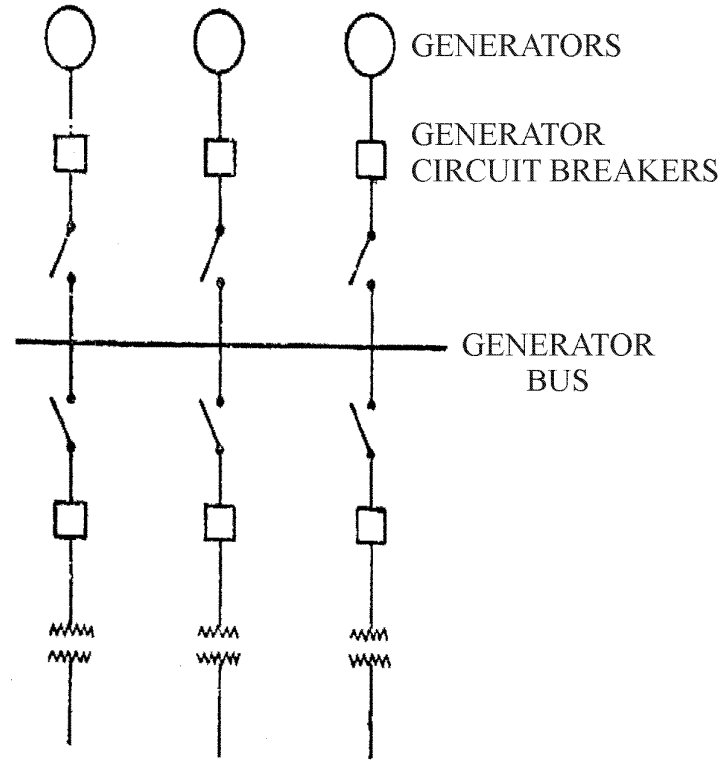
**Generating stations:**

In all these regions, there are switchgears. Bus bars are connecting bars to which a number of local feeders are connected. Bus bars operate at constant voltage. Besides the bus bars, there are other equipment in the electrical schemes such as circuit breakers, CTs, PTs, etc. These equipments can be installed according to various schemes depending upon requirements.

**Equipment in electrical scheme of Transmission system:**

The power transformers are installed between two bus bars of different voltage levels. A power transformer is the costliest, heaviest, and most important equipment in substation.

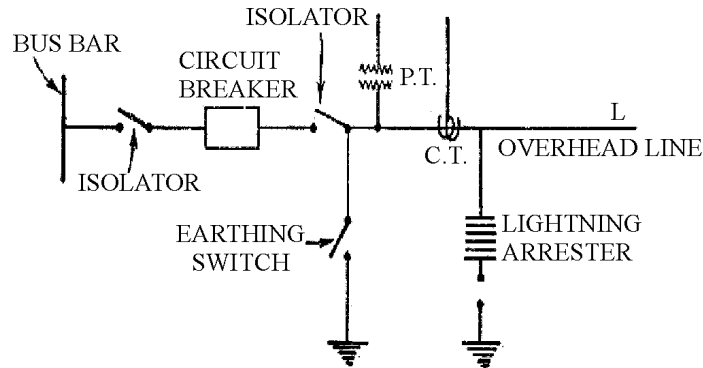

### Typical station in distribution system.

In 11 kV distribution system, the cost of elaborate protection may not be justified for protection transformer upto about 500 kVA. The substations are generally unattended. The H.V fuses is the only protection provided on H.V. side.

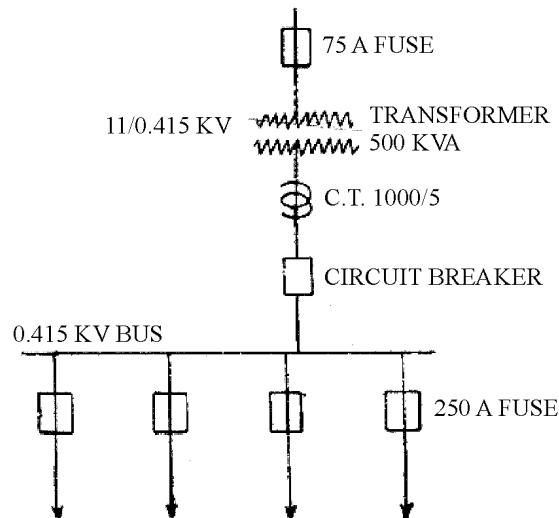

### Receiving system & load points for a medium size industrial work:

The switch gear is installed in the substation of local points, such as industrial works, railway substation, cinema house, large building, foundries etc. The substation has following items:

- Incoming line section
- Transformer section
- Secondary switching section

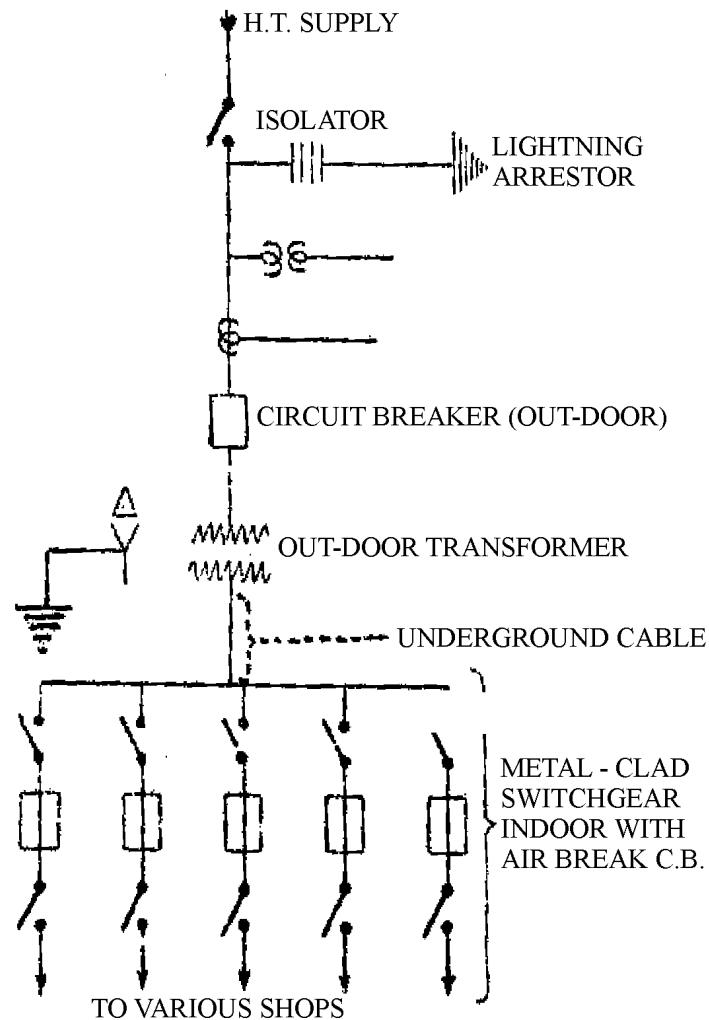
(ii) **Wave energy:**

The periodic rise and fall of water level of the sea can be used to convert wave energy into electrical energy by moving turbine blades from fall and rise of water waves. In about 24 hrs, there are two high & two low waves/ tides. The rise and fall of wave follow sinusoidal curve.

The world first wave/dual power plant was commissioned at 'Range' in France. This plant is of 240 mW capacity. There are three main components of a wave energy power plant as follows:

- The dyke to form basin or basin
- Sluice ways from the basin to sea and vice-versa
- Power house

The turbines, electric generators and other auxiliary equipments are the main equipments of power house.

**Advantage**

- Tidal/wave power has a unique capacity to meet peak power demand effectively when it works in combination with hydropower plant or thermal power

**Disadvantage:**

- Power transmission cost is high because the tidal/wave power plant are located away from load centre.

**(iii) Ocean Thermal energy :**

The conversion of solar energy stored as heat in the ocean into electrical energy by making use of the temperature difference between warm surface water and the colder deep water. The operation of OTEC (ocean Thermal energy conversion) plants is based on a well-established physical (Thermo- dynamics) principle. If a heat source is available at a higher temperature and a heat sink at a lower temperature, it is possible in principle to utilize the temperature difference in a machine or prime mover (Turbine) that can convert the part of the heat taken up from sources into mechanical energy and hence into electrical energy.

The solar energy absorption by the water takes place according to Lambert's law of absorption, which states that each layer of equal thickness absorbs the same fraction of light that passes through it

$$-dI_{(x)} / dx = kI$$

$$\text{or } I_{(x)} = I_0 e^{-kx}$$

Where  $I_0$  and  $I_{(x)}$  are the intensities of radiation at the surface ( $x=0$ ) and at the distance 'x' below the surface,  $k$ = extinction coefficient

**Requirements:**

- Coastal zone land must be available.
- Sea floor must be descended sufficiently rapidly from the shore based plant location.

**Q.61** What are the factors which are involved in circuit breaker rating. (8)

**Ans:** **Factors involved in circuit breaker rating**

The following rated quantities for HV ac circuit breakers

Opening time: interval of time between energizing the shunt trip coil and instant of separation of arcing contact in all poles

Breaking time: it is time between energizing of opening release and the instant of final arc extinction.



Closing time: The time interval between energizing of closing circuit and contact touch with all poles.

Open close time: it is time between separation of arcing contacts all the poles and contact touch in first pole deriving open close operation.

Reclosing time: Time between energizing of shunt trip release and contact toad in all poles.

Close-open time: Time between contact touch in first pole and separation of arcing contact in all poles during close open operation.

The rated characteristics of circuit breaker include rated normal current, rated voltage, rated insulation level, rated transient recovery voltage, rated short circuit breaking current, rated short circuit making current, rated operation sequence etc.

**Q.62** Give a list of the factors involved for selecting a factory drive. (8)

**Ans: Factors involved in selection of factory drives:**

- Supply system : DC or AC
- Rating : kW, MW
- Drive : constant speed, Variable speed
- Special Condition : High starting torque, Hazardous location, Traction duty etc.
- User's requirement : Duty cycle, noise level, load characteristics etc  
off load, load condition
- Enclosures & cooling requirement.
- Environment condition
- Applicable standards
- Cost considerations

**Q.63** What are the various losses occurring in a transformer? (4)

**Ans:** Various losses in a transformer

(i). Core or iron losses: Core flux in transformer remains constant for all load. Its variation is 1 to 3%. This losses are due to eddy current and hysteresis in the core of transformer.

$$W_h = \eta B_{\max}^{1.6} f v \text{ watt} \quad (\text{hysteresis losses})$$

$$W_e = P B_{\max}^2 f^2 t^2 \text{ watt} \quad (\text{eddy current losses})$$

- (ii) Copper losses : These losses are due to ohmic resistance of transformer windings.  
Therefore,  $W_C = I_1^2 R_1 + I_2^2 R_2 = I_1^2 R_{01} \text{ or } I_2^2 R_{02}$

**Q.64** Describe how the synchronous reactance of a synchronous machine is determined. (6)

**Ans:** Synchronous reactance determination of a synchronous machine

$E_o =$  No load e.m.f.

$E =$  On load induced e.m.f.

$V =$  Terminal voltage

$Z = \sqrt{(R_a^2 + X_L^2)}$  i.e: impedance

$I =$  Armature current/phase

$\Phi =$  Load p.f. angle

$X_s =$  Synchronous reactance

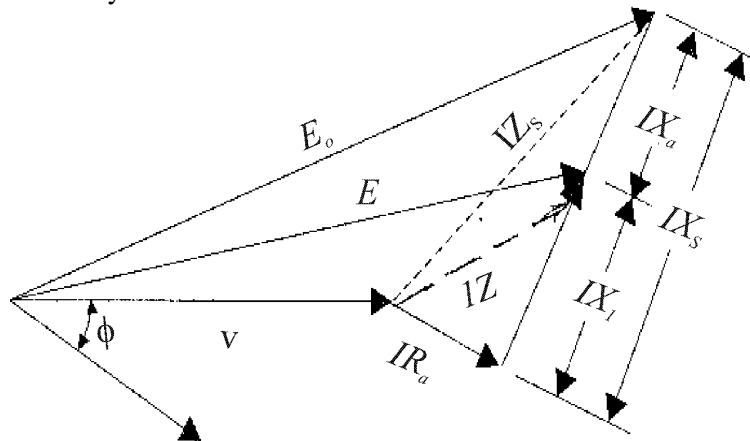

The drop in voltage due to armature reaction may be accounted by assuming the presence of a fictitious reactance  $X_a$  in the armature winding. The value of  $X_a$  is such that  $I.X_a$  represent the voltage drop due to armature reaction. The leakage reactance  $X_L$  (or  $X_P$ ) and the armature reactance  $X_a$  may be combined to give synchronous reactance ( $X_s$ ).

Hence,  $X_s = X_L + X_a$

**Q.65** Explain how speed control is achieved for DC shunt motors. (4)

**Ans:** Speed control for DC shunt motor

- (i) **Flux control method:**  $N \propto 1/\Phi$ , By decreasing flux, the speed can be increased and vice-versa. The flux of d.c. motor can be changed by changing  $I_{sh}$  with the help of shunt field rheostat.

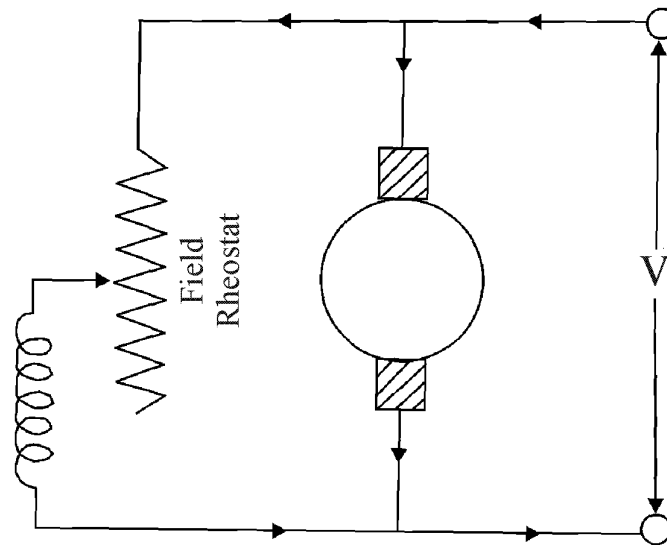
(ii) **Armature control method:**

This method is used when speeds below the no load are required. As supply voltage is constant, the voltage across the armature is varied by inserting a variable resistance in series with the armature circuit.

For load of constant torque, the speed is approximately proportional to the potential drop across the armature. The speed/armature current characteristic shows that greater the resistance in armature circuit, greater fall in speed.

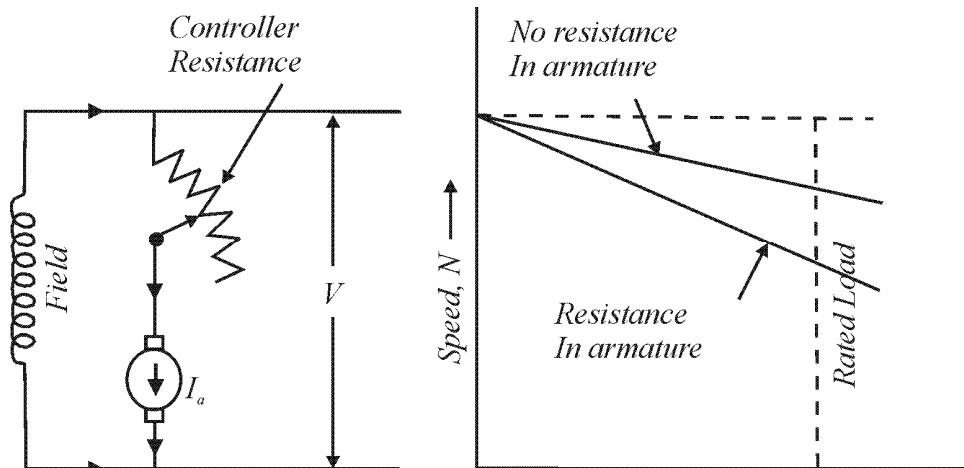

$$N_1 \propto (V - I_{a0} R_a)$$

$$\text{Or } N_1 \propto E_{b1}$$

$$\text{and } N_2 \propto (V - I_{a2} R_t)$$

$$R_t = (R + R_a) \text{ Additional resistance added with armature in series}$$

$$\begin{aligned} \therefore \frac{N_2}{N_1} &= \frac{E_{b2}}{E_{b1}} \\ &= \frac{V - I_a R_t}{V - I_{a0} R_a} \end{aligned}$$

(iii) **Voltage control Method**

Multiple voltage control : Here shunt field of motor is connected permanently to a fixed exciting voltage, but armature is supplied with different voltages by connecting it across one of the several different voltages by means of suitable switchgear.

**Ward Leonard System:** This system is used for wide range of speed control (i.e: 10:1) and it will provide a very sensitive speed control as required in colliery winders, electric excavators, elevators.

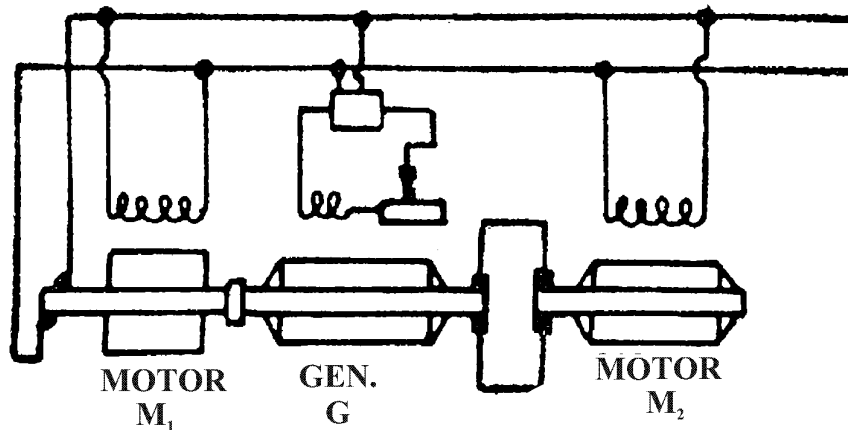

By applying variable voltage across its armature, any desired speed can be obtained. This variable voltage is supplied by a motor-generator set which consists of either d.c. or an a.c. motor  $M_2$  directly coupled to the generator.

**Q.66** Explain how the circuit model of an induction motor is obtained from no-load and block-rotor tests. (4)

**Ans:** (a) Induction Motor model :

(i) **No Load Test**

$X_{01}$  = total leakage reactance of induction motor

$G_o$  = conductance

$B_o$  = exciting susceptance

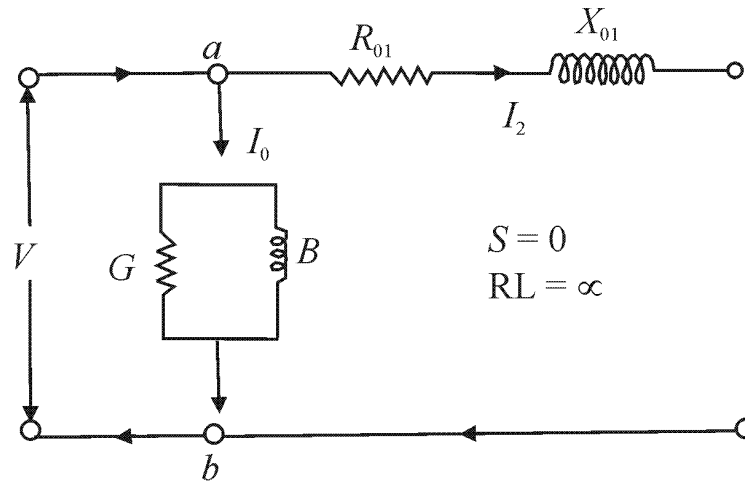

The method is for finding  $G_0$  and  $B_0$  in running motor synchronously so that slip  $S = 0$ . In practice it is impossible for an induction motor to run at synchronous speed, due to friction and windage losses. Therefore, induction motor runs at synchronous speed by another machine, which supplies the friction and windage losses. In this case, the above circuit behaves like an open circuit.

Therefore,  $s = 0$

$$R_L = \infty$$

Hence current drawn by motor is  $I_0$  only.

Let  $V =$  applied voltage/phase

$I_0 =$  Motor no load current /phase

$W =$  Wattmeter reading i.e. input power in watt

$Y_0 =$  exciting admittance of Motor

$$W = 3G_0 V^2 \text{ or } G_0 = W/3V^2 ; (G_0 \text{ is no load conductance})$$

$$I_0 = V \cdot Y_0 \text{ or } Y_0 = I_0/V$$

$$B_0 = \sqrt{(Y_0^2 - G_0^2)} = \sqrt{((I_0/V)^2 - G_0^2)}$$

$$W_0 = \sqrt{3} \cdot V_L \cdot I_0 \cdot \cos \Phi_0$$

$$\cos \Phi_0 = W_0 / \sqrt{3} \cdot V_L \cdot I_0 ; \quad \begin{array}{l} V_L = \text{Line voltage} \\ W_0 = \text{No load stator input} \end{array}$$

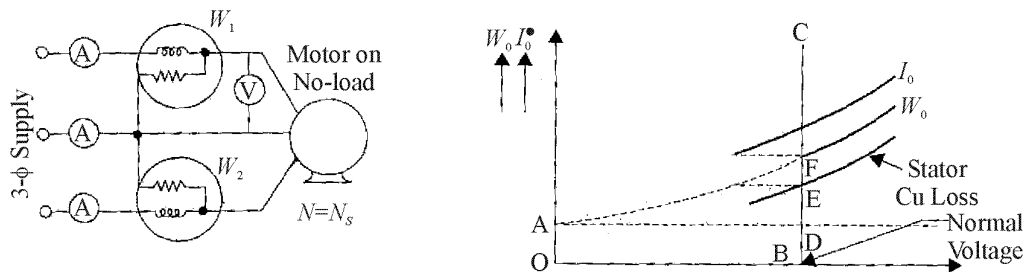
**(ii) Blocked rotor test**

In this test we find:

- Total leakage reactance  $X_{01}$  of motor referred to primary (i.e. stator)
- Total resistance of the motor  $R_{01}$  as referred to primary.

These values are used to describe model Induction Motor. In this case rotor is locked or allowed very slow rotation and rotor windings are short circuited at slip rings.

$$I_{SN} = I_S \times (V / V_S) \quad ; \quad I_{SN} = \text{Short circuit current}$$

$$I_S = \text{Short circuit current with } V_S$$

$$\text{Total 'Cu' Losses} = W_S - W_{CL} ;$$

$$3I_S^2 R_{01} = W_S - W_{CL}$$

$$W_{CL} = \text{core losses}$$

$$W_S = \sqrt{3} I_{SL} \cos \Phi_S = \text{total power input on short current}$$

$$V_{SL} = \text{Line voltage on short current}$$

$$I_{SL} = \text{Line current on short current}$$

$$R_{01} = (W_S - W_{CL}) / 3I_S^2$$

$$Z_{01} = V_S / I_S$$

$$X_{01} = \sqrt{Z_{01}^2 - R_{01}^2}$$

$$X_1 = X'_2 = (X_{01} / 2)$$

$$\text{And } R'_2 = R_{01} - R_1$$

**Q.67** Draw the torque-speed characteristics of a single phase induction motor and explain how it can be obtained. (6)

**Ans: Torque-speed characteristics of a single phase induction motor**

Torque developed by a single phase induction motor depends on its speed. But relationship can not be represented by simple equation. It is easier to show the relationship between

torque  $T$  and speed  $N$  in the form of curve. In this curve, it has been observed that at  $N=0$ ,  $T_1 = 1.5T$  and  $T_{\max} = 2.5T$ . This is called breakdown Torque.

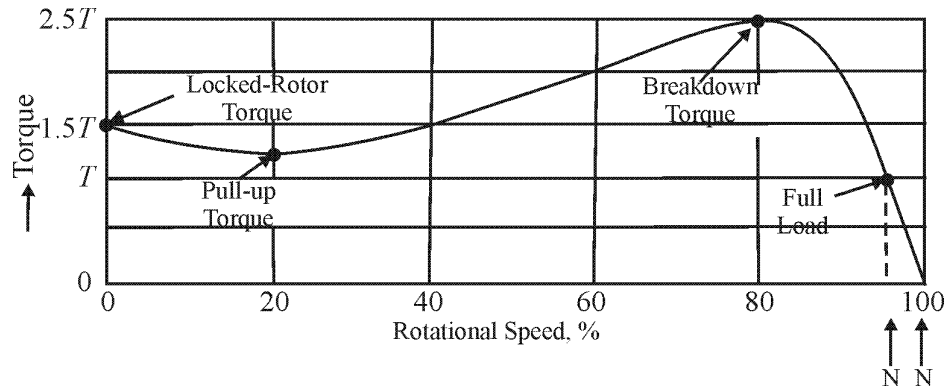

At full load, the motor runs at a speed of  $N$ . when mechanical load increases, the motor speed decreases till motor torque again becomes equal to the load torque. As long as the torques are in balance, the motor will run at constant speed but lower speed. If the load torque exceeds to  $2.5T$ , then motor will suddenly stop.

**Q.68** List out the important advantages of HVDC transmission. (8)

**Ans:**

**Important advantages of HVDC transmission :**

- Economical in long distance high power transmission.
- HVDC transmission line has only two conductors.
- Reactive power losses do not occur in HVDC.

**Q.69 (a)** Describe the primary and back-up protection features that are provided for transmission lines. (8)

**(b)** Describe a typical coreless type of induction furnace and its special features. (8)

**Ans: a Primary and back-up protection:**

The primary protection is essential protection provided for protecting a machine. As a precautionary measure, an additional protection is generally provided and is called a "Back up protection". The primary protection is the first to act and back-up protection is the next in the line of defence. Therefore, if primary protection fails, the back-up protection comes into action and removes the faulty part from one healthy system.

When main protection is inoperative for purpose of maintenance, testing etc. The back-up protection acts like main protection. The back up protection can be classified as:

- **Relay back-up** : Same circuit breaker is used by both main and back-up protection, but protective systems are different. Separate trip coils may be provided for the same-breaker.
- **Breaker Back-up:** Different breakers are provided for main and back up protection, both the breakers are being in the same station.
- **Remote back-up:** Main & back up protection provided at different stations and are completely independent.
- **Centrally coordinated back-up:** Here system is having central control and it can be provided with centrally controlled back-up. The central coordinating station receives information about the abnormal conditions through high frequency carrier signals. The stored programme in digital computer determines the correct switching operation as regard severity of faults, system stability etc. Main protection at various stations and back-up protection for all stations is at central control centre.

**b Coreless induction furnace and its special features.**

The coreless furnace consists of a crucible formed from a refractory material, which contains the charge to be melted. This crucible is surrounded by a helical induction coil (also called inductor) through which the alternating current flows. The heavy currents are introduced in the charge by transformer action. The heat results from  $I^2R$  effect within the charge. The advantages of induction furnaces, in general, include faster and efficient melting, relatively low melting cost. Higher temperature can be attained, can be used for temperature holding etc. The induction furnaces are used for melting, temperature holding, and super heating purposes.

Special features are:-

- Line frequency coreless induction furnace.
- Medium frequency coreless induction furnace.

**Q.70** Write notes on ANY TWO of the following:

- (i) Differential relays.
- (ii) Inductive interference in a transmission line.
- (iii) Nickel-cadmium cells. (8+8)

**Ans: (i) Differential relays**

The differential relay responds to vector difference between two or more similar quantities.

- The differential relay has at least two actuating quantities say  $I_1, I_2$
- The two or more actuating quantities should be similar i.e. current 1 & current 2.



- The relay responds to the vector difference between two i.e.  $I_1 \sim I_2$  which includes magnitude and/or phase angle difference.

Differential protection is generally a unit protection. The protected zone is exactly determined by location of CTs. The vector difference is achieved by suitable connection of CT or PT secondaries.

(ii) **Inductive Interference in Transmission lines:**

Inductive interference depends upon gradient of voltage at surface of conductor or corona. The inductive reactance affected from conductor attenuation at 1000 kHz varies from 0.3 to 0.9 dB/mtr.

(iii) **Nickel cadmium cell**

Nickel cadmium cells employ a solution of potassium hydroxide in distilled water as electrolyte with a specific gravity of 1.200 at 16°C.

- Anode: NiOH and specially treated graphite
- Cathode: CdO, Fe<sub>2</sub>O<sub>3</sub>  
Cadmium oxide or iron oxide.
- AV. Voltage 1.2 V/Cell  
1.3 V/Cell when fully charged.

The condition of battery can be determined with a voltmeter during charge or discharge, while charging Ni-Cd battery, the temperature of electrolyte should not be allowed to exceed 46°C. The battery does not bubble the gas until after the first 4½ hrs when charging at the 7 Amp rate. No finishing rate is needed. The voltage of charger should not be above 1.85 volt per cell.

**Application :**

**Type:**

- |   |             |
|---|-------------|
| (1) Air craft, Emergency power application,<br>Industrial power supply communication<br>Equipment | Vent type   |
| (2) Portable tools, Photography   | Sealed type |

**Q.72** Give the lay-out of a typical thermal-power plant and briefly explain the working of the super heater and the condenser. (8+4+4)

**Ans:** The Layout of a Typical Thermal Power Plant

Main components of thermal power plants are:

- A furnace to burn the fuel

- Steam generator or boiler containing water. Heat generated in the furnace is utilized to convert water into steam.
- Main power unit e.g. (Engine or turbine) to use the heat energy of steam and perform work.
- Piping system to convey steam and water.

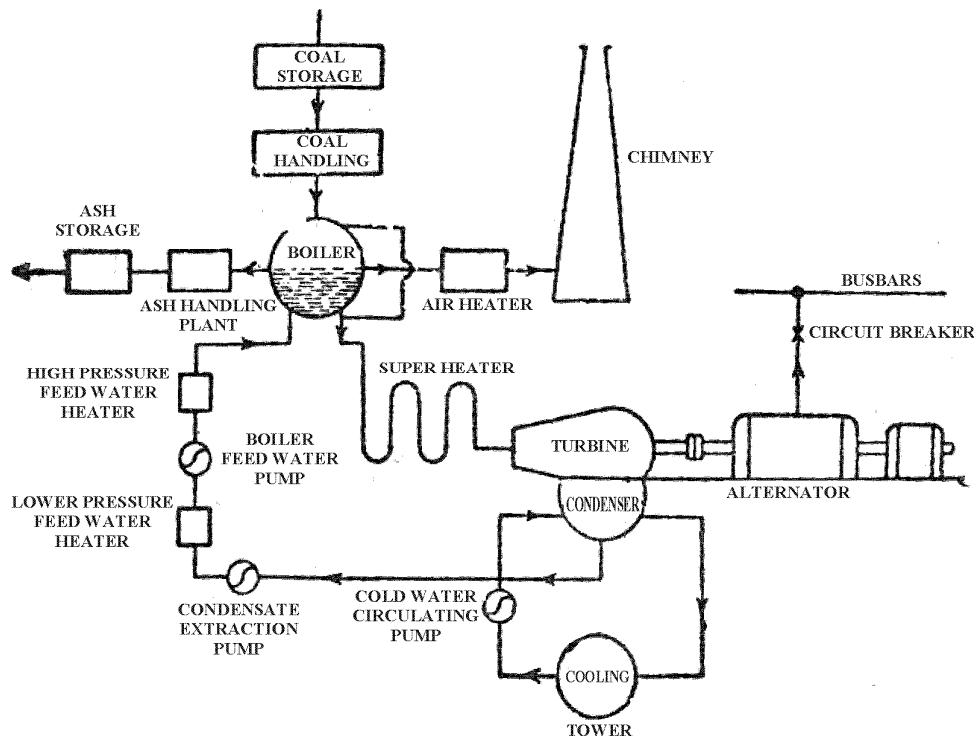
**Layout**Explanation of super heater and condenser:

- Super heater:** The steam produced inside boiler is nearly saturated. This steam as such should not be used in the turbine because the dryness fraction of the steam-leaving boiler will be low. This results in the presence of moisture, which causes corrosion of turbine blades etc. Therefore, to rise the temperature of steam, super heater is used. It consists of several tube circuits in parallel with one or more return bends connected between headers. Super heater tube range is from 1 to 2 inch in diameter.
- Steam condenser:** Steam condenser is required to receive the exhaust steam from the turbine or engine to condense it and maintain a pressure of the exhaust lower than atmospheric. Some extra work is obtained due to exhaust at pressure lower than the atmospheric. This improves the efficiency of the plant. Air inside the condenser should be pumped out continuously in order to maintain vacuum. The condensation of steam occurs in the range of  $25^{\circ}\text{C}$  to  $38^{\circ}\text{C}$ .

**Advantages:**

- It improves power output and efficiency.
- It recovers most of the feed water, which save amount of fuel to be burnt in boiler.
- It decreases the size of boiler installation.

**Q.73** With a neat diagram describe the construction of a lead acid cell and explain the process of charging and discharging of the cell. (8+4+4)

**Ans: Construction of lead acid cell and process of charging and discharging of cell:**

A lead acid type batteries are known as secondary battery or cell, which can be charged for reuse. This cell has following components:

- Anode or positive plate: It consist lead peroxide deposited on grid frame of antimony lead alloy.
- Cathode or positive plate: It consists of porous-spongy lead pasted on grid frame.
- Electrolyte : Sulphuric acid is an electrolyte. It is prepared by diluting pure  $H_2SO_4$  & specific gravity of fully charged cell is 1.23 at  $27^{\circ}C$ .
- Separator : These are thin porous sheet suspended between positive and negative electrode to prevent short circuit.
- Vent plugs: Its purpose is to allow/escape of gases but prevent escape of electrolyte.
- Battery terminals : These are made of nickel plated copper alloy.
- Container : It contains all plates, electrolyte, separators, vent plug, cell connectors and battery terminals. It is made of hard rubber.
- Cell connectors : These are used to connect a number of cells of same type (either negative or positive) in series so as to provide required voltage.

**Charging process:**

Connect dc supply to electrodes with corresponding polarity. The direction of current now opposite to that in discharging process. The current flow from external dc source to positive electrode to negative electrode through the electrolyte and back to the source. This process results in rise in cell voltage 2 or 2.1 volts and specific gravity 1.230

The reaction taking on electrodes are :

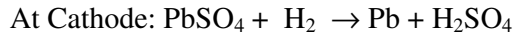
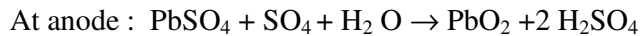

Discharging process:

When cell is fully charged anode is  $\text{PbO}_2$  and cathode is  $\text{Pb}$ . An external load is connected to electrodes of cell, therefore, an electric current flows in load. The process is known as discharging. A fully discharge cell has a voltage 1.8 volts and specific gravity 1.180.

The reaction-taking places at electrodes are

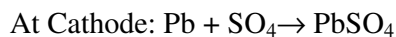
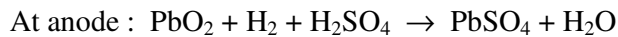

- Q.74** (a) What are the criteria for the classification of transmission lines as short, medium and long lines? (8)
- (b) Draw the schematic diagram of a directional overcurrent relay and explain its working. (4)
- (c) What are the advantages of high voltage transmission and its limitations. (4)

**Ans: (a) Classification of transmission lines (Power)**

The network of transmission lines is formed by three phase AC system. This is required for Bulk power transfer from large group of generating stations to main transmission network.

Short power transmission line:

Short distance power transmission lines has voltage  $\leq 11000$  volts. These lines are required to carry power from main sub-station to local distribution area. Further power supply is distributed through pole mounted sub- station or plinth mounted sub-station.

Medium power transmission line:

Medium distance power transmission line has voltage range 33-132 kV. For the economic voltages for medium lines an approximate rule is  $1 \text{ kV/mile}$  or  $0.6 \text{ kV/km}$ .  $\text{kV} = 5.5 \sqrt{\text{km}} \times 0.6 + \text{kW}/100$ . These lines supply power directly to big organization or industry, which establishes own sub-station.

Long power transmission line

A long distance power transmission line has voltage range 220 kV to 750 kV. These lines are used for transfer of power from sending end to receiving end or for system inter-connection for exchange of power between independently controlled networks. For longer transmission lines, higher power transmission voltages are necessary ( $p \propto v^2$ ). Higher voltage gives lesser current, lesser  $I^2R$  losses, higher power transferability.

**(b) : Schematic diagram of directional over current relay with its working:**

Diagram:

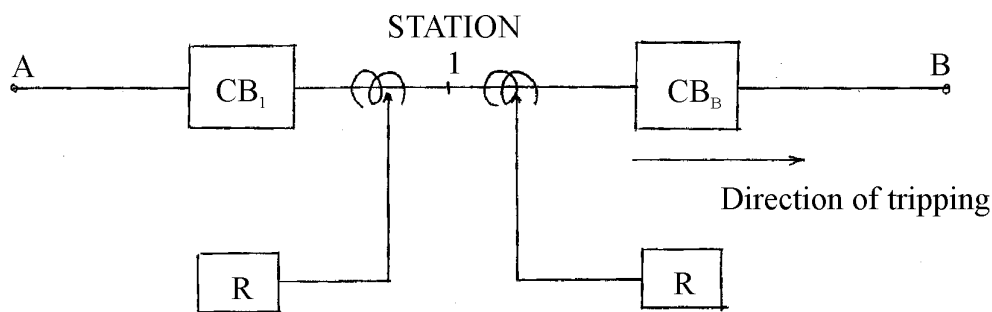

The directional over current protection comprises over current relay and power directional relay in a single relay casing. The power directional relay does not measure the power but it is arranged to respond the direction of power flow. The directional operation of relay is used where the selectivity can be achieved by directional relaying. The directional relay recognizes the direction in which fault occur relative to the location of relay. It is set such that it will actuate for fault occurring in one direction only. It does not act for faults occurring in the other directions. In above diagram consider a feeder AB phasing through subsection 1. The circuit breaker in feeder 1B is provided with a directional relay R, which will trip the CB, if fault power flow in direction 1B alone. Therefore, for faults in feeder 1A, the CB does not trip unnecessarily. However, for faults in feeder 1B,  $CB_B$  trips.

**(c) Advantages and Limitations of high voltage transmission line:**

The choice of transmission systems and rated voltages for a transmission line is made from HV AC (upto 220 kV) EHV AC (400 kV – 750 kV) UHVAC (above 760 kV AC) depending upon technical and economic consideration.

**Advantages :**

- High power transferability of AC lines  $P \propto V^2$ .

- Line losses decrease with increase of transmission voltage and improvement of power factor for same power transfer.
- Bulk power transfer from large group of generating stations upto main transmission network.

**Limitations:**

- Higher voltage gives lesser current, lesser  $I^2R$  losses
- **Short circuit levels:**  
In case of very long lines of above 500 km, intermediate switching sub-stations are necessary to install the shunt reactors for compensation.
- **Right of way:**  
In some cases of big cities, industrial localities, it is impossible to acquire right of way for EHV AC lines.
- **Line insulation:**  
The creep age distance (leakage distance) determined on the basis of required impulse with stand level.
- **Corona:**  
The critical value of voltage stress depends upon pressure, temperature, humidity, pollution level in air.

**Q.75** Write short notes on **ANY TWO** of the following:

- Capacitor-start motor.
- Switched reluctance motor.
- Stepper motor.

**(8+8)**

Ans: (i) Capacitor start Motor

Diagram:

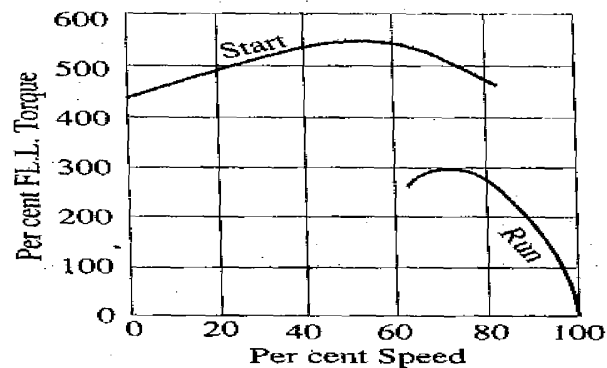
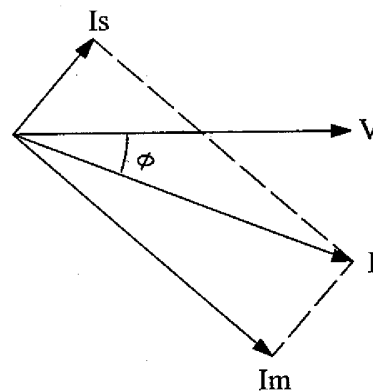
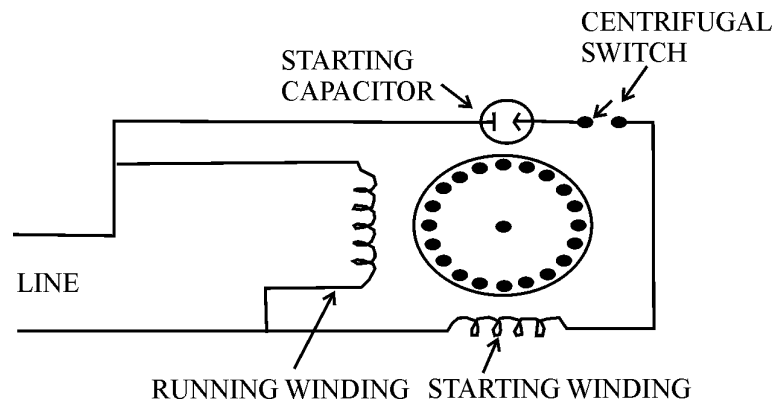

In this motor, necessary phase difference between  $I_s$  and  $I_m$  is produced by connecting a capacitor in series with the starting winding as shown in above figure. The capacitor is generally electrolyte type and mounted on the outside of the motor. This capacitor is designed for extremely short duty service and is guaranteed for not more than 20 periods of operation per hour, each period not to exceed 3 seconds. When motor reaches about 75% of

full speed, a centrifugal switch S opens and cuts off both starting winding and capacitor from the supply. Thus leaving only the running winding.

The torque developed by split phase motor is proportional to size of the angle between  $I_s$  &  $I_m$ .

(ii) **Switched Reluctance Motor :**

This type of motor has either conventional split phase stator and a centrifugal switch for cutting off auxiliary winding or a stator similar to that of permanent split capacitor run motor. The stator produces revolving field. The working of this motor is that when a piece of magnetic material is located in a magnetic field, a force acts on the material, tending to bring it into the most dense portion of a field. The force tends to align the specimen of material in such a way that the reluctance of the magnetic paths that lies through the material will be minimum.

When stator winding is energized, the revolving magnetic field exerts reluctance torque on the unsymmetrical rotor tending to align the salient pole axis of the rotor with the axis of revolving magnetic field. If the reluctance torque is sufficient to start the motor and its load, the rotor will pull into step with the revolving field and continue to run at speed of revolving field. However, rotor poles lag behind stator poles by certain angle known as torque angle.

The constant speed characteristic of a reluctance motor makes it very suitable for signaling devices, recording instruments, timers, phonograph etc.

(iii) **Stepper Motors**

This motor rotate through a fixed angular step in response to each input current pulse received by its controller. These motors can be controlled directly by computers, microprocessors and programmable controllers. These motors used for precise positioning of an object or precise control of speed without using closed loop feed back. The unique feature of this motor is that its output shaft rotates in series of discrete angular interval or steps, one step being taken each time a command pulse is received. When a definite number of pulses are supplied, the shaft turns through a definite known angle. So that the motor is well suited for open loop position control because no feed back is taken from output shaft.

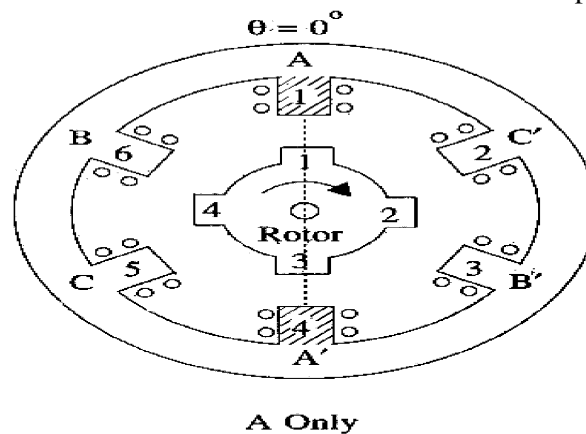



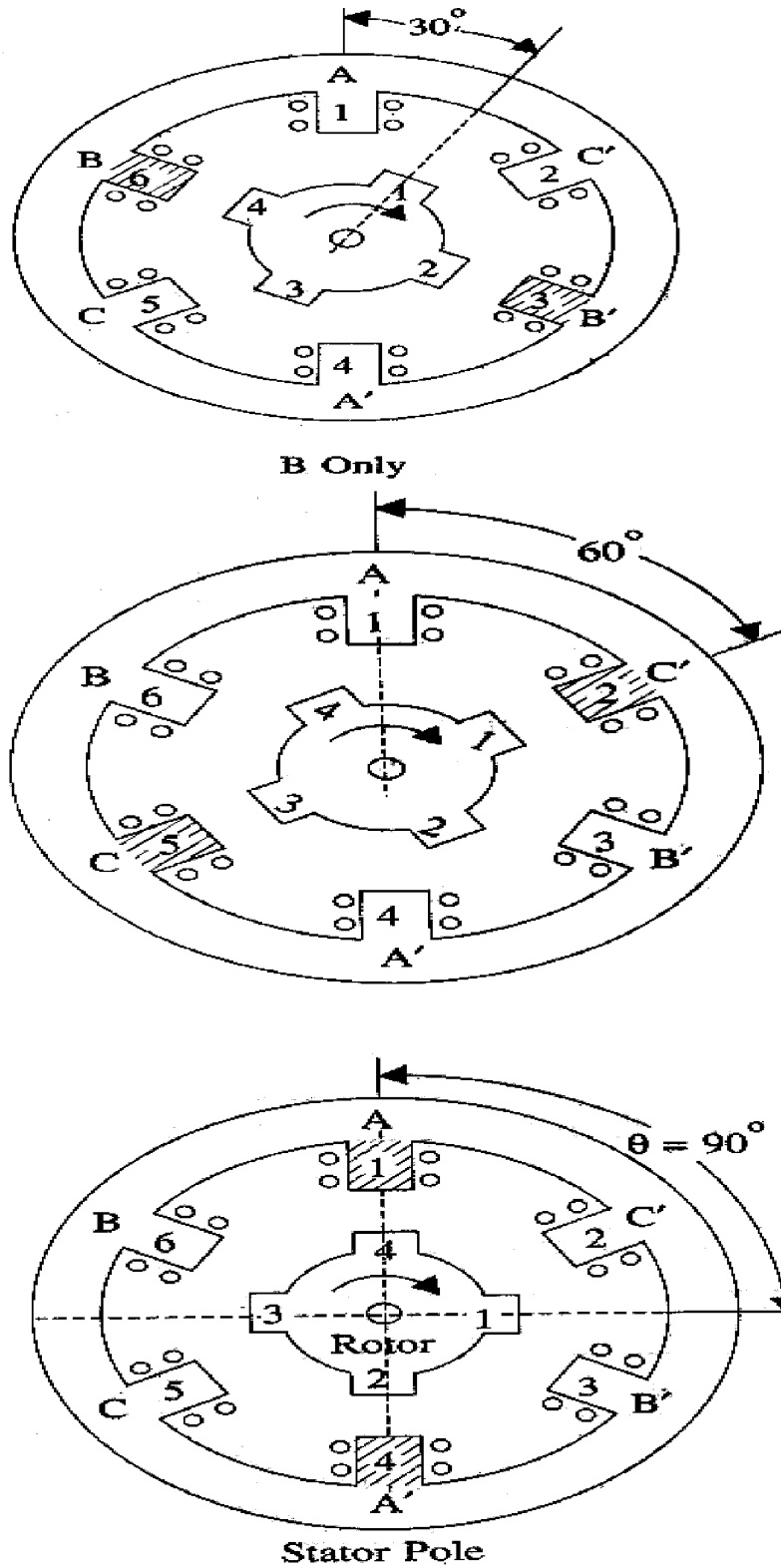

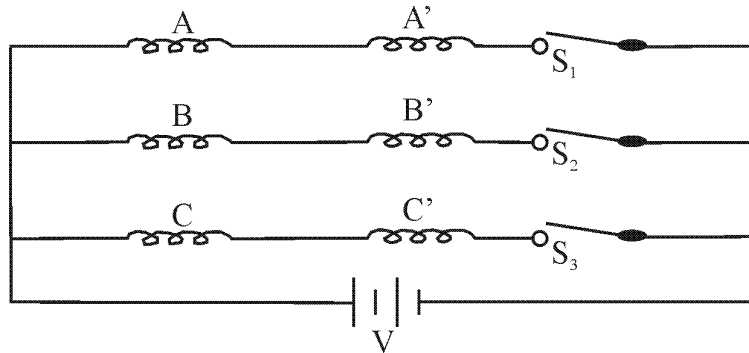

Truth Table

A	B	C	$\theta$
+	0	0	$0^0$
0	+	0	$30^0$
0	0	+	$60^0$
+	0	0	$90^0$

### 1 PHASE -ON Mode ABCD

These motors develop torques ranging from 1 MN upto 40 N-m in a motor of 15 cm diameter suitable for machine tool applications. Their power output ranges from about 1 W to Max of 2500 W. The moving part in stepper motor is its rotor which has no winding, commutator or brushes. Therefore, the motor is quite robust and reliable.

**Q.76** What are the conditions for satisfying parallel operation of single phase transformer? Deduce an expression for the load shared by the two transformers in parallel when the transformers have equal voltage ratio. (8)

**Ans:** Condition for parallel operation of single phase Transformer :

- Voltage ratio (K) should be same.
- Per unit percentage impedance should be same.
- Polarity should be same.
- The phase sequence should be same.

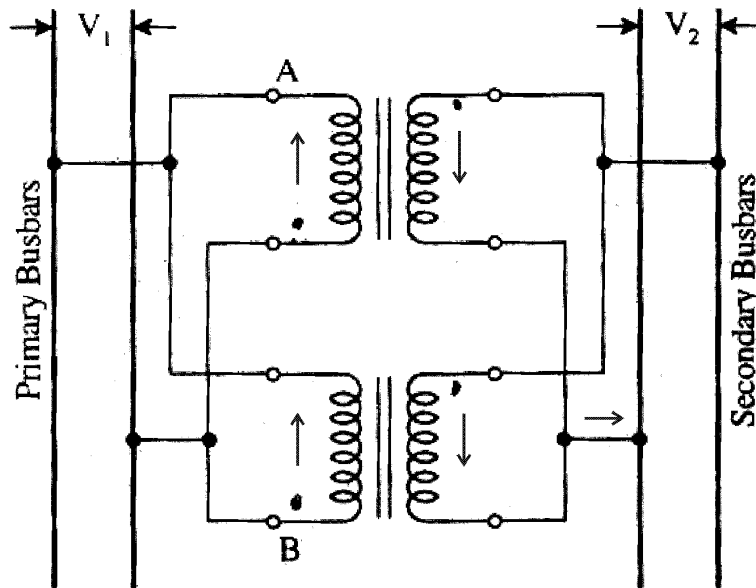

$V$  = Secondary voltage

$I_1$  = Input current

$I_2$  = output current

$v$  = voltage drop

$v = I_1 Z_1 = I_2 Z_2 = I Z_{12}$

$Z_{12} = Z_1 \parallel Z_2$

$I$  = equivalent current at output

$Z_{12} = Z_1 Z_2 / (Z_1 + Z_2)$  ;

$I_1 = v / Z_1 = I Z_{12} / Z_1 = I \{ Z_1 Z_2 / (Z_1 + Z_2) \} / Z_1$

$\therefore I_2 = I Z_1 / (Z_1 + Z_2)$

$\therefore I_1 = I Z_2 / (Z_1 + Z_2)$

and  $I_1 V = V I Z_2 / (Z_1 + Z_2) = VI \{ Z_2 / (Z_1 + Z_2) \}$

$I_2 V = VI \{ Z_1 / (Z_1 + Z_2) \}$

**$KVA_1 (S_1) = kVA \cdot VI \{ Z_2 / (Z_1 + Z_2) \}$**

**$KVA_2 (S_2) = kVA \cdot VI \{ Z_1 / (Z_1 + Z_2) \}$**

**Q.77** Explain two important functions served by the damper winding in a synchronous motor. State the various applications of synchronous motor. (7)

**Ans:** Important functions of damper winding in a synchronous motor:

- The oscillatory motion of the rotor about the operating point is considerably reduced in amplitude and rotor quickly returns to the steady position.
- Providing starting torque like an induction motor.
- At starting, the rotor achieves a speed close to synchronous speed and the rotor and stator fields lock into each other as soon as field excitation is switched on.

Various applications of synchronous motor :

- It is capable of being operated under a wide range of power factors, both lagging and leading. Hence, it can be used for power factor correction purpose.
- In textile industry high speed drives are necessary with wide range of control. Variable frequency drives with synchronous motors are used for speed control.
- In chemical industry, rubber industry and petrochemical industry, many processes require compressor drives in which direct coupled synchronous motors supplied by frequency converters are used.
- An artificial fibre plant needs variable frequency synchronous motor and are supplied by static frequency converters.
- Synchronous motor is also useful for voltage regulation.

**Q.78** Explain the process of building up of voltage in d.c. shunt generator and give the conditions to be satisfied for voltage built-up. (7)

**Ans:** The DC shunt generator runs at constant speed and some emf will be generated due to residual magnetism in the main poles. This small e.m.f circulates a field current, which produces an additional flux to reinforce the original residual flux. This process will continue and generator builds up the normal generated voltage.

$$\therefore E_0 = iR_f + L \frac{di}{dt}$$

$R_f$  = total field resistance

$L$  = Inductance of field circuit

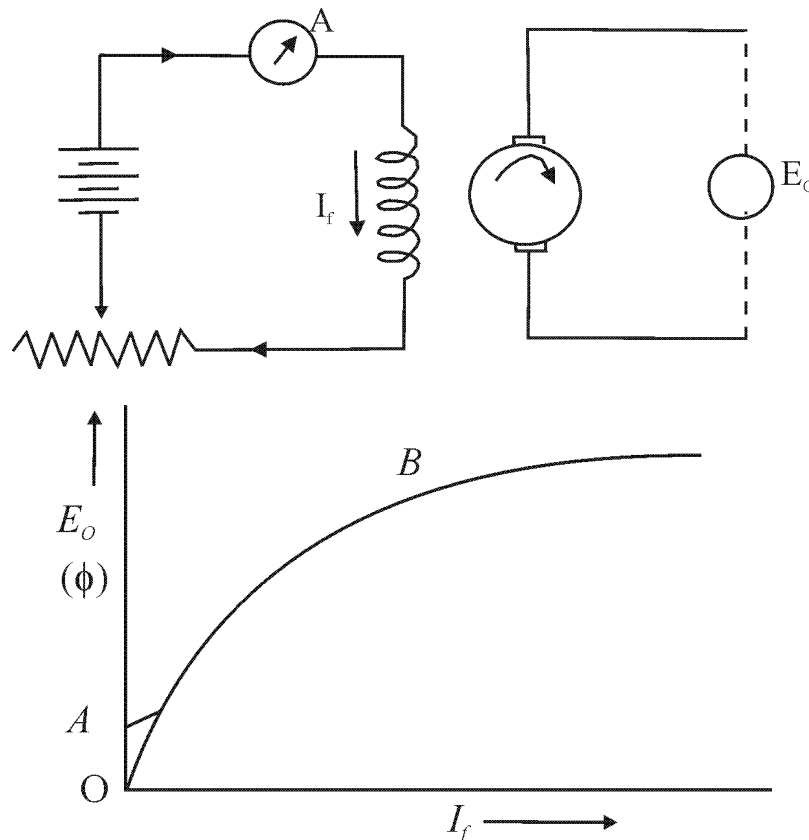
**Condition to be satisfied are:**

- Proper connection of field circuit winding.
- $E_o$  depends on field circuit resistance.

- Q.79 (a)** Why does the induction motor not rotate at synchronous speed? (3)
- (b)** Describe with the aid of diagram of connection, phasor diagram and torque-slip characteristics, the working of capacitor-start single phase induction motor. (5)

**Ans (a) Induction motor does not rotate at synchronous speed**

The rotor of a induction motor never succeeds in catching up with stator field. If it really did, there will be no relative speed between stator and rotor field. Hence, no rotor e.m.f, no rotor current. Therefore, no rotor torque to maintain rotation. That is why rotor runs at speed lower than that of stator and stator field runs at  $N_s$  speed.

$$N_s = 120 f / p \quad \text{and rotor speed } N = N_s (1-s)$$

**(b) Capacitor-start single phase induction motor**

The necessary phase difference between  $I_s$  and  $I_m$  is produced by connecting a capacitor in series with starting winding. The Capacitor is generally electrolytic type and its usually mounted on the outside of motor. The capacitor is designed for short duty service and when motor reaches 75% of full load speed. The centrifugal switch 'S' opens and cuts out starting winding and capacitor from supply only main winding

remains in circuit. The torque developed depends on angle between  $I_m$  &  $I_s$ , that is approximate  $80^\circ$ .

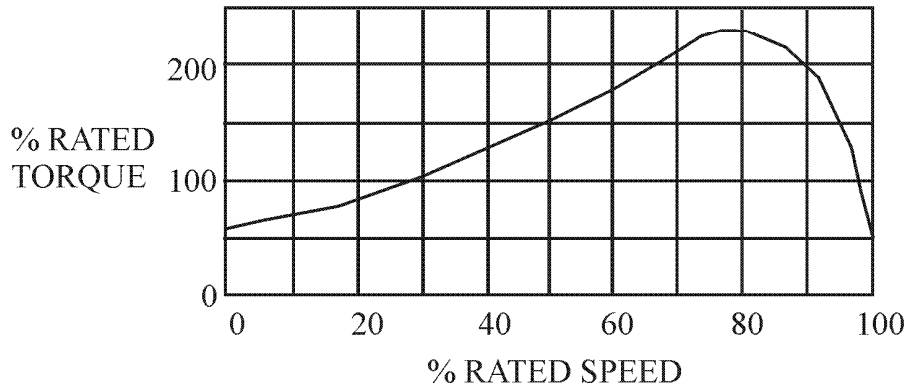
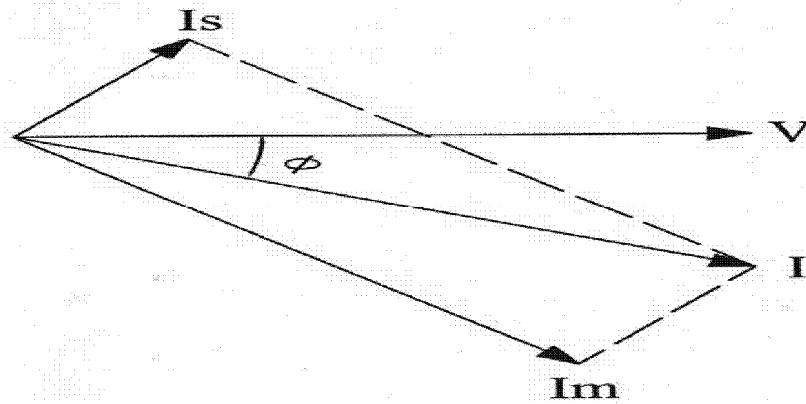
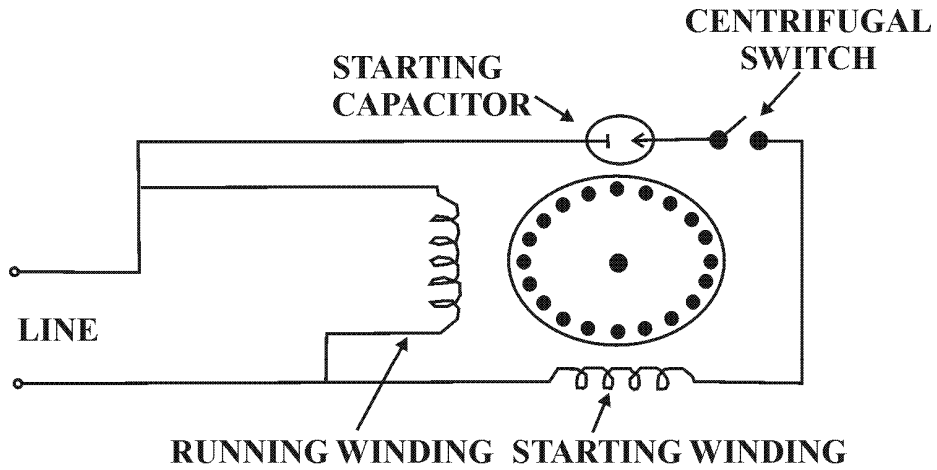

**Q.80** Explain the principle of operation of two phase servo motor. Draw its torque-slip characteristics. (8)

**Ans:** The Principle of operation of two-phase servo motor:

For low power (few hundred watts) control applications, the two phases (balanced) servo motor is ideally switched. As it can be driven by means of a relatively rugged (drift free) as an amplifier. The motor torque can be easily controlled by varying the magnitude of a.c voltage applied to the control phase ( $V_a$ ) of the motor, while second phase called reference phase (phase  $V_{in}$ ) is excited at a fixed voltage. Synchronous a.c voltage must be drawn from the same source. The control phase is shifted in phase by  $90^\circ$  from the reference phase voltage by means of a phase shifting networks included in voltage application stages of amplifier. The motor torque gets reversed by phase reversal of control phase voltage.

For linear stable operation, the speed torque- characteristics of a servomotor must be linear with negative slope (torque reducing with increasing speed). It is suitable for the position control system.

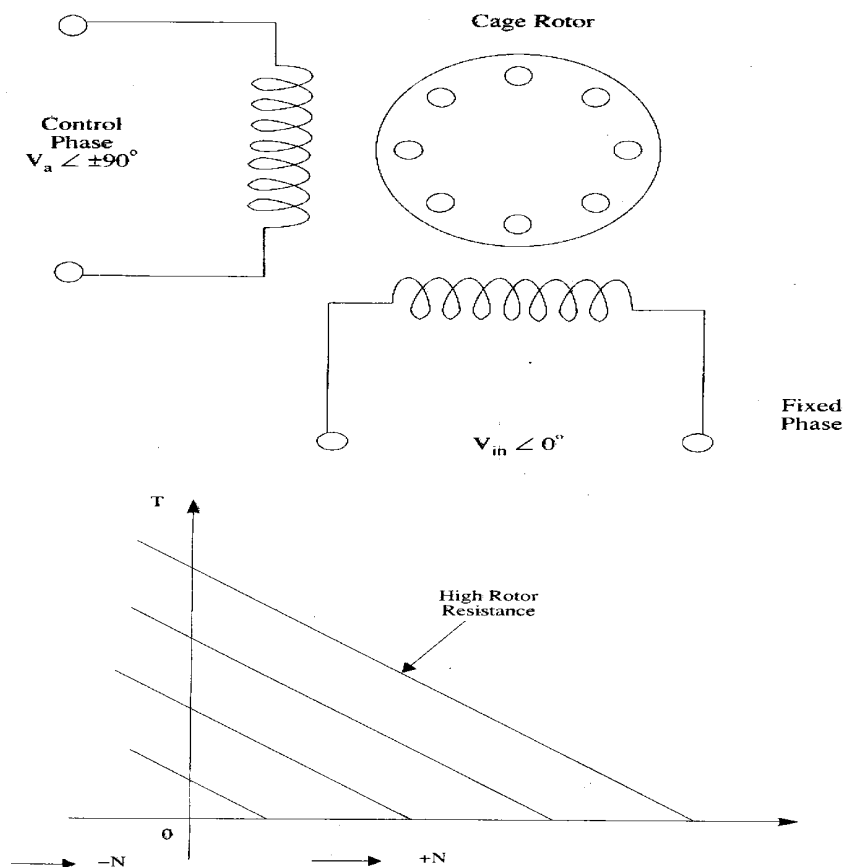

**Q.81** Write short note on following: (8)

- (a) Condenser in Thermal power plant
- (b) Control of nuclear reactor

**Ans: (a) Condenser in Thermal Power Plant**

The steam after expansion through the turbine goes to condenser to improve efficiency of the power plant by decreasing the exhaust pressure of the steam below atmosphere. Another advantage of condenser is that condensed steam can be recovered and this provides a source of good and pure feed water to the boiler. Thereby, reducing considerably the water softening plant capacity. The air and non condensable gases are removed from the steam, when it passes through the condenser.

**(b) Control of Nuclear reactor:**

Once fission process is started in a few nuclei of fission materials, it should be able to continue throughout the remaining material without external interference. For each act of fission, nearly 2.5 neutrons capable of causing further fission are proceeded. A self-sustaining chain reaction is not possible. The leakage of neutron through it is inevitable. Both fission and non fission reduces the number of neutrons actually available to maintain the chain reaction.

The reproduction factor (k) is defined as:

$$k = \frac{\text{number of neutrons of any one generation}}{\text{number of neutrons of immediately proceeding generation}}$$

$k = 1$  ; means chain reaction will continue.

$k > 1$  ; means chain reaction will be building up.

$k < 1$  ; means chain reaction will be dying down(due critical)

The desirable requirement of power reactor is that the system should be critical i.e  $k = 1$ . When we want to control reactor, we have to change the value of k. At the time of starting the reactor value of k has to be raised above 1. This will increase the power level.

Once the required power level has been reached, k is to be reduced to 1 and should be kept at this value as long as the out-put rate is to be kept constant. When the load on the



reactor is to be lowered, the  $k$  has to be reduced to slightly less than 1 till the required power level has been reached. At this point  $k$  has to be brought back to 1. Similarly, while shifting down the reactor, the  $k$  has to be reduced to less than 1, the chain reaction will die down.

**Q.82** Describe the construction, principle of operation and advantages of SF<sub>6</sub> circuit breaker. (8)

**Ans:** (a) **SF<sub>6</sub> Circuit breaker**

Working of SF<sub>6</sub> Circuit breaker

In general, the circuit breakers consist of two main parts, the poles and the mechanism. The poles consist of contact and arc-extinguishing devices. The mechanism is the part to open or close the contacts in the poles at the same time instantaneously (with max. 5 millisecon. Tolerance). The closing and opening procedures are performed through springs which are charged by a servomotor and a driving lever. In the system, the closing springs are first charged. If "close" button is pressed, the opening springs get charged while the contacts get closed. Thus, circuit breaker will be ready for opening. The mechanical operating cycle of the circuit breaker is (OPEN-3 Min CLOSE/OPEN-3 Min- CLOSE/OPEN) or (OPEN-0.3 sec- CLOSE/OPEN-3 Min CLOSE/OPEN). The second cycle is valid when the circuit breaker is used with re-closing relay. In that case, after the closing operation, the closing springs are charged by the driving lever or by driving motor (if equipped). Thus, the circuit breaker will be ready for opening and re-closing.

When manual or motor-drive is used, the circuit breaker will be ready to close. The closure can be actuated by pressing the closing button located on the circuit breaker. It is recommended to close it using remote control system for secure operations. The opening can be performed either by opening button or remote controlled opening coil. In case of a fault, the relay signal actuates the opening coil and circuit breaker opens. (This is mechanically a primary protection system). In addition, there is an anti-pumping relay for preventing the re-closing and opening of the circuit breaker more than one cycle (O - C - O) and for preventing possible troubles created by remote closing button.

### CROSS SECTION OF A 16 kA POLE AND PART NAMES

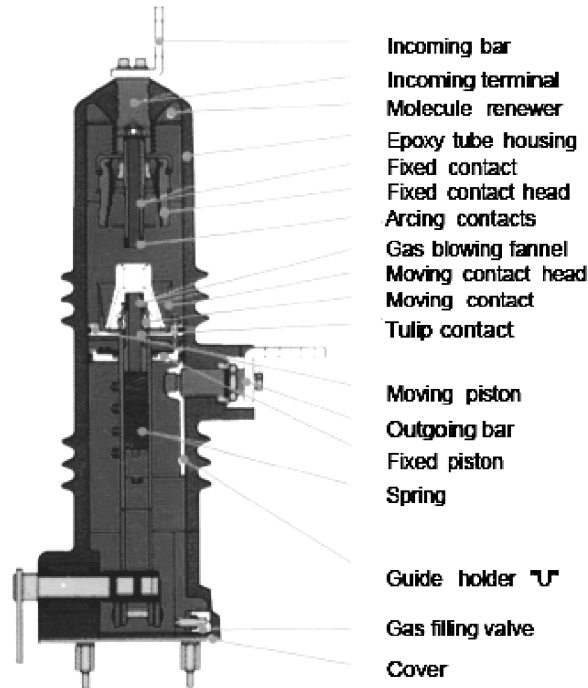

### Applications:

Sulfur Hexafluoride (SF<sub>6</sub>) has an excellent gaseous dielectric for high voltage power applications. It has been used extensively in high voltage circuit breakers and other switchgears employed by the power industry. Applications for SF<sub>6</sub> include gas insulated transmission lines and gas insulated power distributions. The combined electrical, physical, chemical and thermal properties offer many advantages when used in power switchgears. Some of the outstanding properties of SF<sub>6</sub> making it desirable to use in power applications are:

- Very high dielectric strength
- Very unique arc-quenching ability
- Very excellent thermal stability
- Very good thermal conductivity

**Q.83** Write short note on any two of the following:-

- (i) Application of dielectric heating
- (ii) Speed control of D.C. motor using chopper
- (iii) Differential Relay

**(8+8)**

**Ans: (i) Application of Dielectric heating:**

- Since cost of dielectric heating is very high, so it is employed where other methods are not applicable.
- For baking of sand cores, which are used in the moulding process.
- For preheating of plastic compounds before sending them to moulding section.
- For drying of tobacco after glycerine has been mixed with in making cigarettes.
- The baking of biscuits and cakes etc. in the bakeries with the help of automatic machine.
- For dehydration of food which is then sealed in air-tight containers.
- For removal of moisture from oil emulsion.
- In diathermy for relieving pain in different parts of the human body.
- For quick drying of glue used for book binding purposes.

**(ii) Speed control of DC motor using chopper:**

$$\begin{aligned}V_{dc} &= V_L = V \times (T_{ON} / (T_{ON} + T_{OFF})) \\ &= V \times (T_{ON} / T)\end{aligned}$$

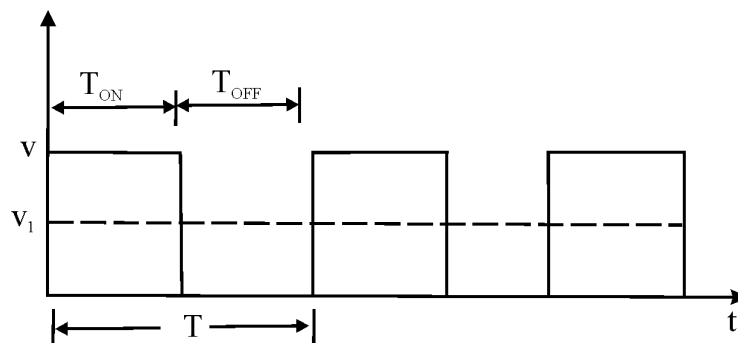
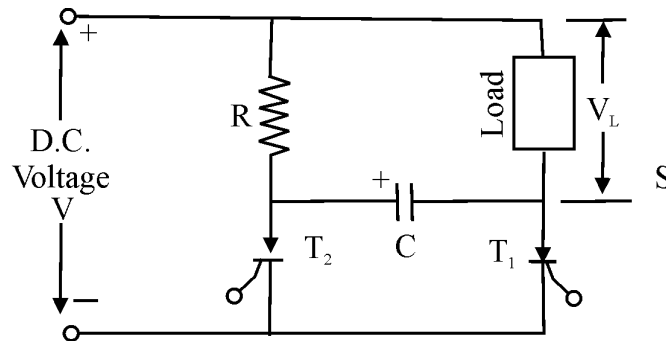

The average output voltage of a thyristor controlled rectification can be changed with the help of a thyristor chopper circuit, which can be made to interrupt dc supply at different rate to give different average value of dc supply. The dc voltage so obtained can be thus chopped with the help of thyristor chopper circuit.

Since the thyristor can be switched ON- OFF very rapidly, they are used to interrupt a dc supply at regular frequency in order to produce an average (mean) dc supply voltage. This is achieved from low level dc voltage to high level dc voltage. The thyristor  $T_1$  is used for dc chopping and resistance 'R'. The capacitance 'C' & Thyristor ' $T_2$ ' are used for commutation purposes. When  $T_1$  is fixed into conduction by its control circuit, the current is set up through the load and common capacitance 'C' gets charged via 'R' with polarity during 'ON' period. When  $T_1$  is 'OFF', second thyristor ' $T_2$ ' is triggered into conduction allowing 'C' to discharge through it (since it acts as short circuit while conducting) which is reversed biased,  $T_1$  thus turns it OFF. The discharge from 'C' leaves  $T_2$  with reverse polarity, so it is turned OFF, whereas  $T_1$  is triggered into conduction again.

It is seen that output voltage is present only when  $T_1$  is ON and OFF. The mean value of output dc voltage depends on the chopped dc output of  $T_{ON}$  &  $T_{OFF}$ .

(iii) **Differential relay :**

A differential relay is defined as the relay that operates when the phaser difference of two or more similar electrical quantities exceed by a predetermined amount. Suppose that current 'I' flows through the primary circuit to external fault. If the two CTs have the same ratio and are connected as shown, no current will flow through the relay and it will remain un-operational.

If now an internal fault occurs and if current flows to the fault from both sides, the current flow through the relay will be  $I_1$  &  $I_2$ . It may be noted that the fault current need not necessary flow to the fault from both sides to cause current flow in the relay. There may be flow of one side only or even same current flowing out of one side, while a large current entering the other side will cause a different current.

This type of differential relay is likely to operate inaccurately with heavy load through faults (external load). suppose identical CTs may not have identical secondary current due to constructional feature and errors or under severe fault condition CTs may saturate and cause unequal secondary currents and its difference of secondary currents may approach the pick-up value of relay. This disadvantage is overcome in percentage differential relay.

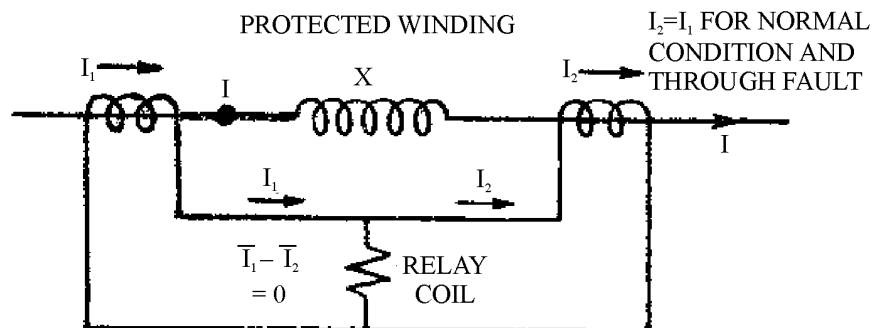
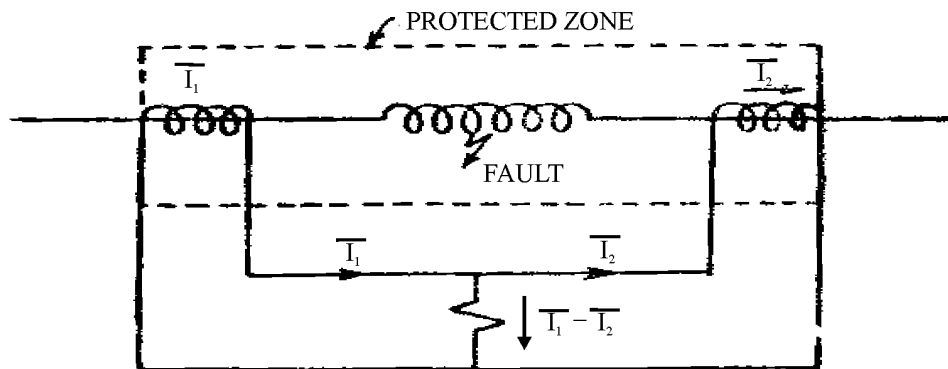

**Q.84** Explain the construction and working principle of a transformer.

(4+4)

**Ans: Transformer Construction:**

The simple element of a transformer consists of two coils having mutual inductance and a laminated steel core. The two coils are insulated from each other with steel core. Other necessary parts are : some suitable container for assembled core windings from its container: Suitable bushings (either of porcelain, oil- filled or capacitor type) for insulating and bringing out the terminals from the tank. Core is constructed of transformer sheet steel laminations, assembled to provide a continuous magnetic path with a minimum of air gap included. Steel used is of high silicon content, sometimes heat treated to produce a high permeability and low hysteresis loss at the usual operating flux-densities. Lamination is of varnish or an oxide layer, which reduces eddy current loss. Thickness of lamination varies with frequency inversely.

Transformers are of 2 general types distinguished by the manner in which primary and secondary coils are placed around the laminated core :

1. Core Type – winding surrounded a considerable portion of the core.
2. Shell Type – core surrounds a considerable portion of windings.

**Working principle :**

A transformer is a static piece of apparatus by means of which electric power in one circuit is transformed into electric power of the same frequency in other circuit. It can raise or lower the voltage in a circuit but with a corresponding decrease or increase in current. The physical basis of transformer is mutual induction between two circuits linked by a common magnetic flux. It consists of two inductive coils which are electrically and magnetically linked through a path of low reluctance. The 2 coils possess high mutual inductance. If one coil is connected to a source of alternating voltage , an alternating flux is set-up in laminated core, most of which is linked with other coil in which it produces mutually induced emf (according to Faraday's law of EMI  $e = M di/dt$ ). If the second coil circuit is closed, a current flows in it and so electric energy is transferred (entirely magnetically) from the first coil to the second coil. The first coil in which electric energy is fed from A.C. supply mains is called primary winding and other from which energy is drawn out, is called secondary winding.

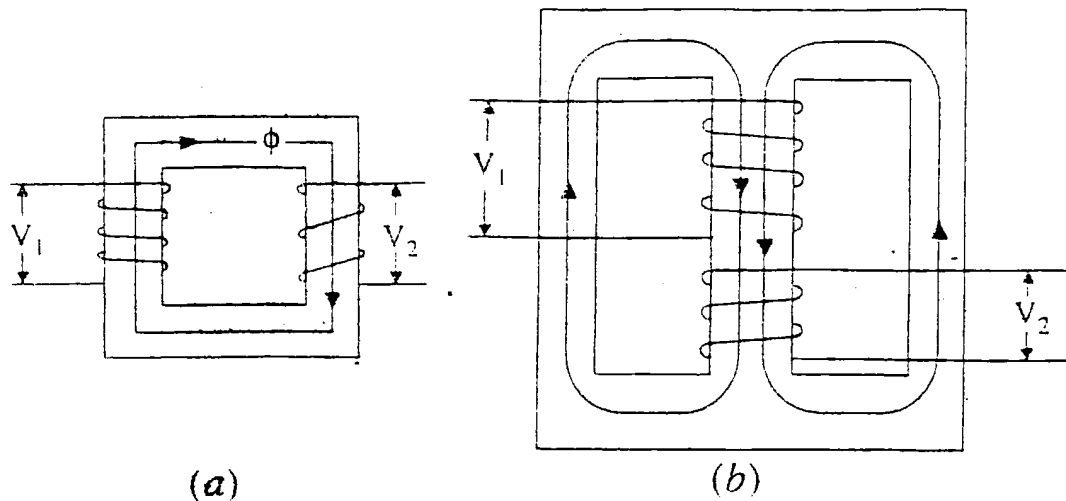

**Q.85** What are the two types of constructions that are employed in synchronous machines? Explain the two machines and give with reasons which of them are simple to model and analyze. (2+4+2)

**Ans:** Two types of construction employed in synchronous machine are salient pole and smooth cylindrical rotor type.

(i) Salient pole type or Projecting Pole Type:

It is used in low and medium speed (engine driven) alternators. It has a large number of projecting (Salient) poles, having their cores bolted or dove tailed onto a heavy magnetic steel of cast iron or steel of good magnetic quality. Such generators are characterized by their large diameters and short axial lengths. The poles and pole shoes (which cover  $2/3$  of pole-pitch) are laminated to minimize heating due to eddy currents.

(ii) Smooth Cylinder Type:

Used for steam turbine driven alternators i.e. turbo alternators which run at very high speeds. Rotor here is designed mostly for 2-pole (or 4 pole) turbo generators running at 3600rpm (or 1800 rpm).

The central polar area is surrounded by the field windings placed in slots and the field coils are so arranged around these polar areas that flux density is maximum on the central polar line and gradually falls away on either side. It should be noted that poles are non-salient i.e., they do not project out from the surface of rotor. To avoid excessive peripheral velocity, such rotors have very small diameters (about 1m or so). Hence, turbo generators are characterized by small diameters and very long axial (or rotor) length. The cylindrical construction of rotor gives better balance and quieter-operation and less windage losses.

Cylindrical types are much easier to analyze than salient pole types because they have uniform air gap, whereas in salient pole type air gap is much greater between the pole than along the poles. Fortunately cylindrical rotor theory is reasonably accurate in predicting the steady state performance of salient pole type. Hence salient pole theory is required only when very high degree of accuracy is needed or when problems concerning transients or power system stability are not handled.

**Q.86** Explain the characteristics of DC motors. Also give their applications. (6+3)

**Ans:** The characteristic curves of a motor are those curves which show relationships between the following quantities:

1. Torque and armature current i.e  $T_a / I_a$  characteristic. It is known as electrical characteristic.
2. Speed and armature current i.e  $N / I_a$  characteristic.
3. Speed and Torque i.e  $N / T_a$  characteristic. It is known as mechanical characteristic.

Characteristics of series motor :

i.  $T_a / I_a$  characteristic:

$$T_a \propto \Phi I_a$$

$$\Phi \propto I_a \text{ (up to the point of magnetic saturation.)}$$

Hence, before saturation

$$T_a \propto \Phi I_a \text{ and therefore } T_a \propto I_a^2$$

As  $I_a$  increases,  $T_a$  increases as the square of the current. Hence,  $T_a / I_a$  curve is a parabola before saturation. After saturation characteristic, becomes straight line because  $T_a \propto I_a$  (for  $\Phi$  is independent of  $I_a$ )

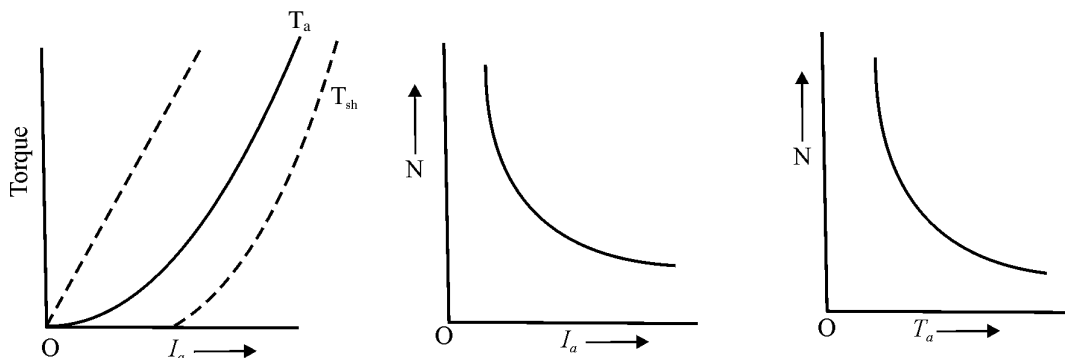

ii.  $N / I_a$  characteristic:

$$N \propto E_b / \Phi$$



With increased  $I_a$ ,  $\Phi$  also increases. Hence, speed varies inversely as armature current. When load is heavy,  $I_a$  is large hence speed is low; this decreases  $E_b$  and allows more armature current to flow. But when load current and hence  $I_a$  falls to small value, speed becomes dangerously high. So series motor should never be started without some mechanical load on it.

iii.  $N / T_a$  characteristic :

When speed is high, torque is low and vice – versa.

Characteristics of shunt motor :

i.  $T_a / I_a$  characteristic:

Assuming  $\Phi$  to be constant (at heavy loads ,  $\Phi$  decreases somewhat due to increased armature reaction), we find that

$$T_a \propto I_a$$

Hence, the electrical characteristic, practically is a straight line through the origin, that torque is shown dotted. Since a heavy starting load will need a heavy starting current, shunt motor should never be started on heavy load.

ii.  $N / I_a$  characteristic:

Assuming  $\Phi$  to be constant, then  $N \propto E_b$ . As  $E_b$  is constant, speed is constant.

But, both  $E_b$  and  $\Phi$  decrease with increasing load. However  $E_b$  decreases slightly more than  $\Phi$  so there is some decrease in speed. The drop varies from 5 to 15% of full load speed, being dependent on saturation, armature reaction and brush position. Hence the actual speed curve is slightly drooping as shown by dotted line. But for all practical purposes, shunt motor is taken as a constant speed motor.

iii.  $N / T_a$  characteristic can be deduced from (i) and (ii) above and is shown in Fig :

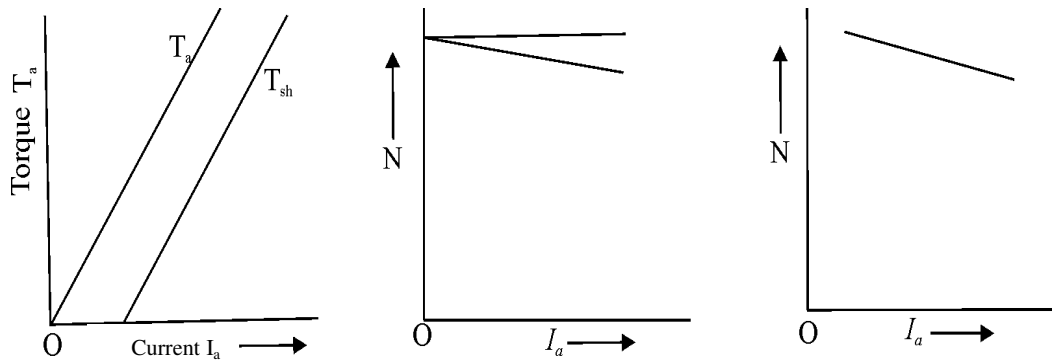

### Characteristics of Compound motor

- a) Cumulative –compound motors:

The characteristics of compound motors lie in between those of shunt and series motors. Here series field is in the same direction with shunt field; due to shunt winding, speed will not become excessively high but due to series windings, it will be able to take heavy loads.

- b) Differential –compound motors:

Since the series field opposes the shunt field, the flux is decreased as load is applied to the motor. This results in motor speed remaining almost constant or even increasing with increase in load. ( $N \propto E_b/\Phi$ )

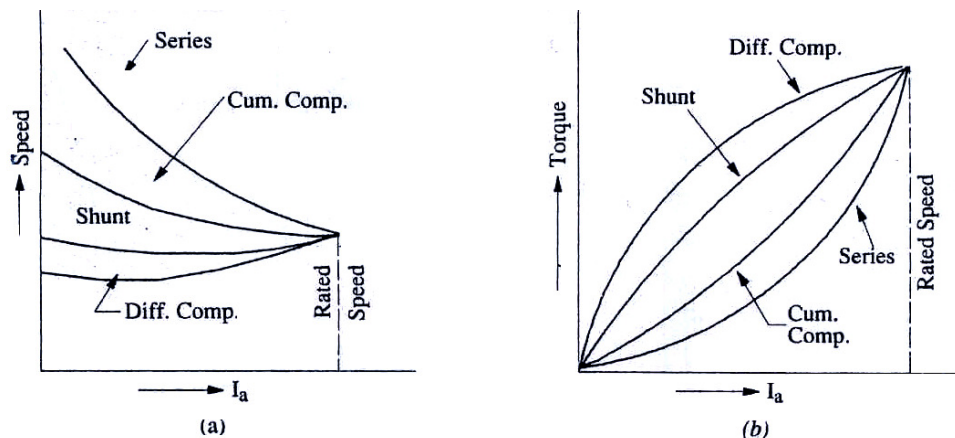

**Applications of DC motors:**

<b>Type of motor</b>	<b>Applications</b>
Series Motor	For traction work, i.e electric locomotives, Rapid transit system, trolley cars etc Cranes and hoists Conveyors
Shunt motor	For Driving constant speed line shafting lathes Centrifugal pumps Machine tools Blowers & Fans Reciprocating pumps
Cumulative Compound	For intermittent high torque loads For shears and punches Elevators Conveyors Heavy planers Rolling mills: Ice machine: Printing Presses: Air Compressors

**Q.87** Explain the different methods of starting an induction motor. (8)

**Ans:**

Methods for starting of squirrel cage induction motors are by

- (a) Primary resistors (or rheostat) or reactors.
- (b) Auto-transformers (or autostarter).
- (c) Star-delta switches.

In above methods, terminal voltage of squirrel-cage motor is reduced during starting.

- a) By using primary resistors, applied voltage can be reduced by a fraction 'x' and torque by  $n^2$  because resistor decreases applied voltage which reduces initial current and current varies directly as voltage. Torque varies as square of applied voltage.

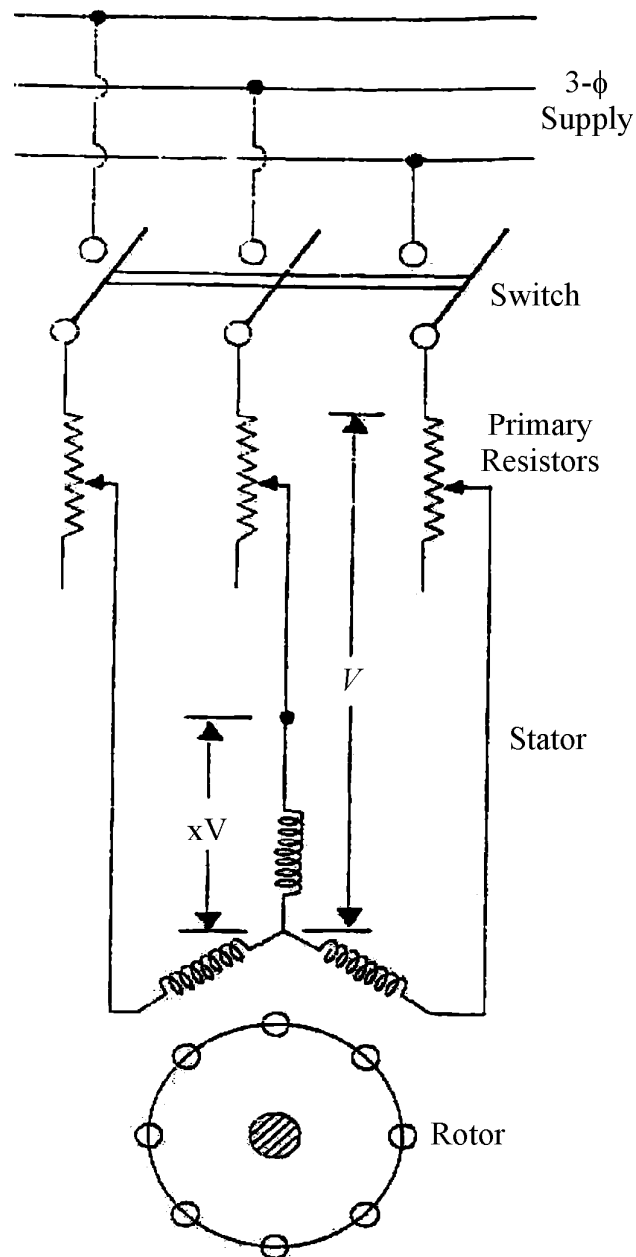

Ratio of  $T_{st} / T_{8C}$  is  $x^2$  of that obtained in direct switching or across line starting.

(b) **Auto-transformers**

This method can be used for both star and delta connected motors with starting connections. A reduced voltage is applied across motor terminals. When motor has run upto say, 80% of its normal speed, connections are so changed that

autotransformers are cut out and full supply voltage applied across motor. The switch taking these adjustments from start to run may be air break (for small motors) or oil immersed (for large motors) to reduce sparking.

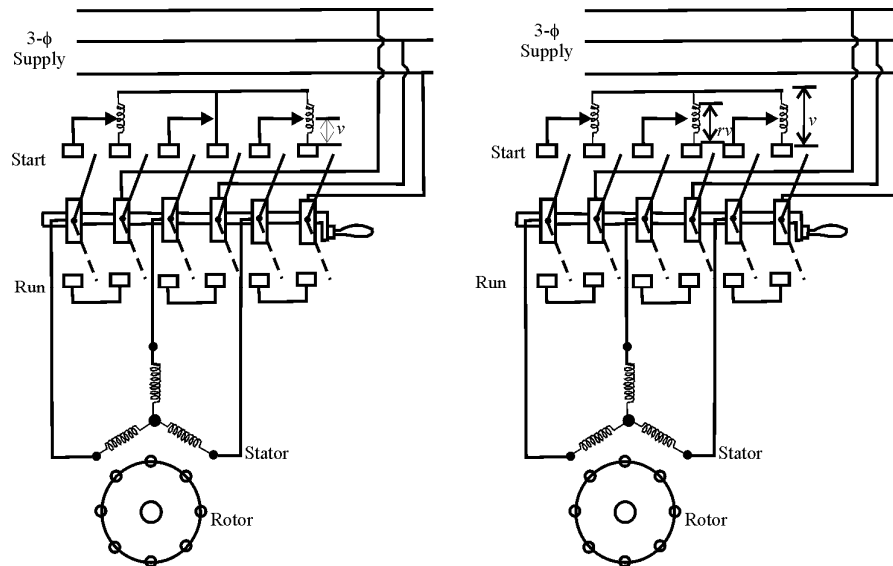

(c) **Star-delta starter**

This method used where motors are built to run normally with a delta-connected wdg. It consists of a 2 way switch which connects motor in star for starting and then in delta for normal running. When star-connected, applied voltage over each motor phase is reduced by a factor  $1/\sqrt{3}$  and hence torque developed becomes  $1/3$  of that which would have been developed if motor were directly connected in  $\Delta$ . The line current reduced to  $1/3$ . Hence during starting period of Y connected it takes  $1/3^{\text{rd}}$  as much starting current and develops  $1/3^{\text{rd}}$  as much torque as would have been developed, were it directly connected in delta.

**Starting of slip-ring Motors**

The controlling resistance is in the form of rheostat, connected in star, the resistance being gradually cut-out of rotor circuit, as motor gathers speed. By increasing rotor resistance not only rotor current is reduced at starting but at the same time starting torque is also increased due to improvement in p.f. The controlling rheostat is either of stud or contactor type and may be hand-operated or automatic.

Introduction of additional external resistance in rotor circuit enables a slip-ring motor to develop a high starting torque with reasonably moderate starting

current. Hence such motors can be started with load. This additional resistance is for starting purpose only. It is generally cut out as motor comes up to speed.

**Q.88** What are the two advantages of stepper motors? Give a few applications of them & explain permanent magnet stepper motors. (2+2+4)

**Ans:** Advantages of stepper motors:

- i) They can be directly controlled by computers, micro-processors and programmable controllers.
- ii) Precision control of speed without using closed loop feedback.

**Applications:**

i) **Operation control:**

Such motors used for operational control in computer peripherals, textile industries, IC fabrications and robotics etc.

ii) **Incremental motion:**

Applications requiring incremental motion are typewriters, line printers, tape-drivers, floppy disk drivers, numerically controlled machine tools, process-control systems and X-Y plotters.

**Others:**

It includes commercial, military and medical applications where these motors perform functions as mixing, cutting, striking, metering, blending and purging. They also take part in manufacture of packed food stuffs, commercial end-products and even the production of science fiction movies.

**Permanent Magnet Stepper motor:**

It has wound stator poles and permanently magnetized rotor poles. It has a cylindrical rotor. Its direction of rotation depends on the polarity of stator current. The stator has projecting poles. Rotor has 2 poles whereas stator has 4 poles and the two stator poles are energized by one winding, the motor has two windings or phases.

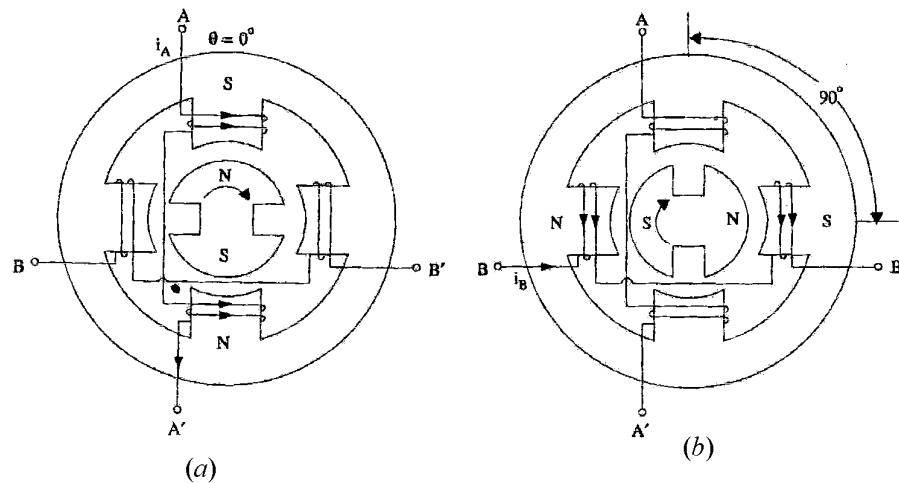
**Working :**

When a particular stator phase is energized, the rotor magnetic poles move into alignment with excited stator poles. The stator wdgs. A and B can be excited with either polarity current ( $A^+$  refers to the +ve current  $i_A^+$  in phase A and  $A^-$  to negative current ( $i_A^-$ ). Fig. shows condition when phase A is excited with the current  $i_A^+$ . Here  $\theta = 0^\circ$ . If excitation is now switched to phase B, the rotor rotates by a full step of  $90^\circ$  clockwise direction. When phase A is excited with  $-ve$  current  $i_A^-$ , the rotor turns through another  $90^\circ$  in clockwise direction. Similarly excitation of phase B with  $i_B^+$  further turns rotor through another  $90^\circ$  in same direction. After this excitation of phase A with  $i_A^+$  makes rotor run through one complete revolution of  $360^\circ$ .

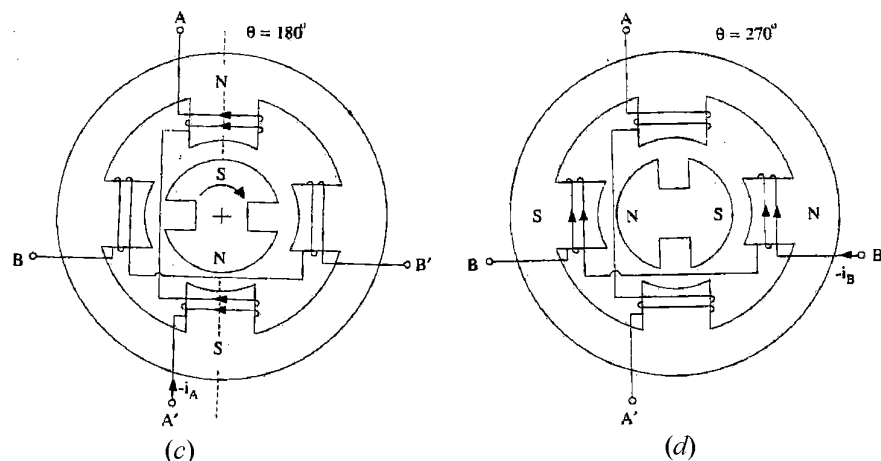

It will be noted that in a permanent magnet stepper motor, the direction of rotation depends on the polarity of phase current as below:-

$$\left. \begin{array}{l} i_A^+; i_B^+; i_A^-, i_B^-, i_A^+ \\ A^+; B^+; A^-; B^-; A^+ \end{array} \right\} \text{Clockwise}$$

$$\left. \begin{array}{l} i_A^+; i_B^-; i_A^-, i_B^+, i_A^+ \\ A^+; B^-; A^-; B^+; A^+ \end{array} \right\} \text{CCW}$$

**Q.89 (a)** Explain the three main blocks of a solid state relay. (8)

**(b)** What is meant by grading of cables? Explain the two methods of grading. (8)

**Ans:** Solid-state relays

A solid-state relay conducts load current through one or more power transistors or thyristors.

There are three main types of SSRs, classified by the type of input.

Reed-relay coupled SSRs send the input signal through the coil of a reed relay. Closure of the reed switch triggers the thyristor into conduction.

Transformer-coupled SSRs send an ac control signal through the primary of a small transformer. (In the case of dc control signals, the input first goes through a DC/AC converter before hitting the transformer primary). Voltage from the transformer secondary triggers the thyristor.

Finally, photo coupled SSRs isolate the input from the output through a photosensitive diode or transistor. A control current actuates a light source which in turn, lets a photosensitive semiconductor conduct trigger-current to actuate the power device.

**(b)** The method of equalizing the stress in the dielectric of the cable is called the grading of cables.

#### **Methods of grading.**

(i) Capacitance grading

(ii) Intersheath grading

**Capacitance grading** is provided within gas insulated lightning arresters containing stacked zinc oxide varistors by means of a grading ring electrically connected to the line terminal or, for arresters of the higher voltage ratings, by means of a plurality of telescoping external electrostatic shields. The shields are arranged so that the degree of overlap between sequential shields decreases from the line end to the ground end of the varistor stacks. The capacitance grading is provided by the degree of overlap between the sequential shields and the ratio of the radii of the overlapping shields.



**Intersheath Grading**

In this method of grading, the same insulating material is used throughout the cable, but is divided into two or more layers by means of cylindrical screens or intersheaths. These intersheaths are connected to tappings from the supply transformer, and the potentials are maintained at such values that each layer of insulation takes its proper share of the total voltage. The intersheaths are relatively flimsy, and are meant to carry only the charging current. Since there is a definite potential difference between the inner and outer radii of each sheath, we can treat each section separately as a single core cable.

- Q.90** (a) Explain the features of a nuclear power plant with a suitable diagram. (6)  
(b) Explain the term “cogeneration” and give two possible ways of cogeneration. (2+2)  
(c) Write a short note on solar energy. (6)

**Ans: Nuclear power station :**

In the nuclear power station, energy is produced by nuclear fission of Uranium ( $U^{235}$ ), Thorium ( $Th^{232}$ ), Plutonium ( $Pu^{239}$ ). The fission process takes place in a nuclear reactor and material in certain circumstances can be made to become unstable and transform themselves into ordinary chemical elements, iron nickel, silicon and calcium and in this process set free a considerable amount of heat energy. Heat thus generated will be taken away by fluid such as molten bismuth or liquid sodium. This hot molten metal will convert feed water into high-pressure steam in a heat exchanger. The steam thus generated is utilized to drive steam turbine coupled to an alternator and exciter, thereby generating electrical energy.

Low temperature and low pressure steam from turbine is condensed in a condenser with the help of circulated cooling water. From the condenser, water is again fed to heat exchanger with the help of a feed water pump for converting it into steam.

In this power station transportation of fuel is not a problem, because one kg of atomic fuel can generate as much electrical energy as can be generated from about 2500 tonnes of high grade coal.

The most suitable areas in our country for atomic power stations are western UP, Rajasthan, Punjab and Haryana

Few examples of atomic or nuclear power stations are as follows:

1. Tarapur Atomic Power Stations, Tarapur near Mumbai.
2. Ranapratap Atomic Power Stations, Kota (Rajasthan).
3. Madras Atomic Power Stations, Kalpakkam (Tamil Nadu).

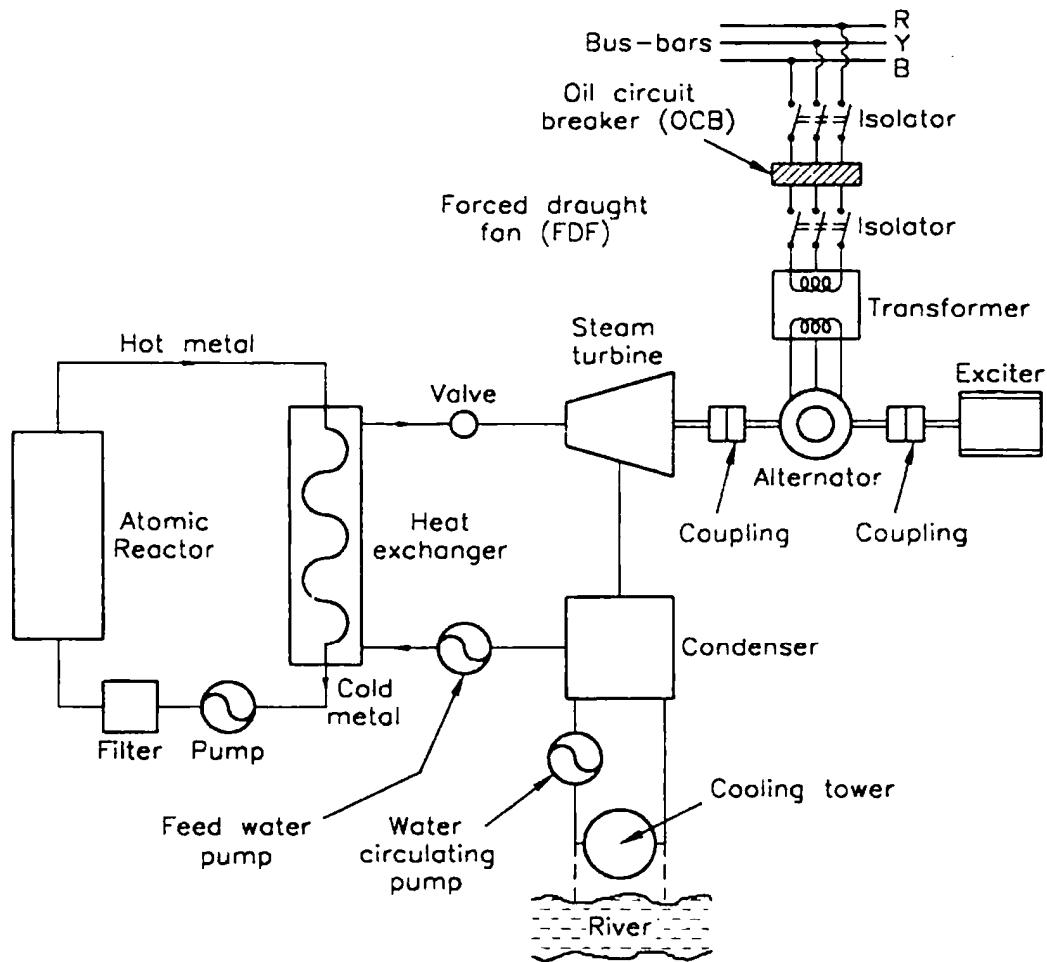

(b) **Co-generation**

Cogeneration is a highly efficient means of generating heat and electric power at the same time from the same energy source. Displacing fossil fuel combustion with heat that would normally be wasted in the process of power generation, it reaches efficiencies that can triple, or even quadruple conventional power generation. Cogeneration equipment can be fired by fuels other than natural gas. There are installations in operation that use wood, agricultural waste, peat moss, and a wide variety of other fuels, depending on local availability.

The environmental implications of cogeneration stem not just from its inherent efficiency, but also from its decentralized character. Because it is impractical to transport heat over any distance, cogeneration equipment must be located physically close to its heat user. Cogeneration plants tend to be built smaller, and owned and operated by smaller and more localized companies than simple cycle power plants. As a general rule, they are also built closer to populated areas, which causes them to be

held to higher environmental standards. In northern Europe, and increasingly in North America, cogeneration is at the heart of district heating and cooling systems. District heating combined with cogeneration has the potential to reduce human greenhouse gas emissions by more than any other technology except public transit.

- (c) Solar energy is the utilization of the radiant energy from the Sun. Solar power is often used interchangeably with solar energy but refers more specifically to the conversion of sunlight into electricity, either by photovoltaic and concentrating solar thermal devices, or by one of several experimental technologies such as thermoelectric converters, solar chimneys and solar ponds.

Solar energy and shading are important considerations in building design. Thermal mass is used to conserve the heat that sunshine delivers to all buildings. Daylighting techniques optimize the use of light in buildings. Solar water heaters heat swimming pools and provide domestic hot water. In agriculture, greenhouses expand growing seasons and pumps powered by solar cells (also known as photovoltaics) provide water for grazing animals. Evaporation ponds are used to harvest salt and clean waste streams of contaminants.

Solar distillation and disinfection techniques produce potable water for millions of people worldwide. Simple applications include clotheslines and solar cookers which concentrate sunlight for cooking, drying and pasteurization. More sophisticated concentrating technologies magnify the rays of the Sun for high-temperature material testing, metal smelting and industrial chemical production. A range of prototype solar vehicles provide ground, air and sea transportation.

- Q.91(a)** What are the advantages of electrically produced heat? Explain the various types of electric heating with their applications. **(2+6)**
- (b)** Explain the salient features of electrical propulsion. **(8)**

**Ans: (a)** Electrically produced heat possesses the following advantages over other forms of Heat:

- i. Cleanliness: The complete absence of dust and ash keeps cleaning cost to a minimum.
- ii. High efficiency of utilization : Practically 75% to 100% Of heat produced can be utilized.
- iii. Absence of fuel gases : No fuel gases produce.
- iv. Ease of control : Simple and accurate control of temperature can be provided.
- v. Low attention and maintenance costs: Electric heating equipments require no attention, while maintenance costs are negligible.

Various types of Electric heating and their applications:

- i. Resistance heating: Two methods are employed in resistance heating.
  - a. Direct resistance heating: In this method , the material or charge to be heated is taken as a resistance and current is passed through it. Resistance and current is passed through it. The charge may be in the form of powder, pieces or liquid. The two electrodes are immersed in the charge and connected to the supply.
  - b. Indirect resistance heating: In this method the current is passed through a high resistance element which is either placed above or below the oven depending upon the nature of the job to be performed. The heat proportional to  $I^2R$  losses produced in the heating element is delivered to the charge either by radiation or by convection.

Applications: Resistance heating is used in heat treatment of metals like annealing and hardening etc., stoving of enameled wires, drying and baking of pottery and commercial and domestic cooking.

- ii. Induction heating:

Induction heating processes make use of currents induced by electromagnetic action in the material to be heated. Induction heating is based at the principle of transformers, there is primary winding through which an ac current is passed. The coil is magnetically coupled with the metal to be heated. An electric current is induced in this metal when the ac current is passed through the primary coil.

Applications:

- Surface hardening
  - Deep hardening
  - Tempering
  - Soldering
  - Melting
  - Smelting etc.
- iii. Dielectric Heating : for the heating of non metallic material i.e. insulators such as wood, plastics, the dielectric loss occurs in such materials when subjected to an alternating electrostatic field. The material to be heated is placed between two metallic electrodes across which a voltage is applied. To ensure sufficient heating an adequate amount of heating frequencies between 10MHz and 30MHz must be used and the voltage needed may be as high as 20kV.

Applications:

- Seaming and welding in manufacture of synthetics.
- In wood processing industry.
- For baking foundry cores.
- For food processing.

iv. Arc Heating :

If an air gap is subjected to a very high voltage, the air in between gets ionized due to electrostatic forces. The ionized air is the conducting material, therefore, the current starts flowing through the air gap in the form of continuous spark or arc. This arc is produced in the arc furnaces by having air gap and electrode. With graphite or carbon electrode the temperature obtained from the arc is between 3000°C and 3500°C.

There are two types of arc furnaces.

- Direct arc furnace.
- Indirect arc furnace.

Applications:

- In production of steel direct arc furnace is used.
- Submerged arc furnace is used for ferrous alloy manufacturer.
- Indirect arc furnace are used for melting of non ferrous metals, it is also used in foundries where small quantities of metal is required intermittently.

**(b) Salient features of electrical propulsion.**

Electric propulsion is a form of space craft propulsion used in outer space. This type of reaction utilizes electric energy to obtain thrust from propellant carried with the vehicle.

Types of electric propulsion :

The various technologies of electric propulsion are usually grouped in three types based on the type of forces used to accelerate the ions of the plasma.

Electrostatic: If the acceleration is caused mainly by the coulomb forces the device is considered electrostatic.

- i. Electrothermal: In this type, electromagnetic fields are used to generate a plasma to increase the heat of the bulk propellant. The thermal energy imparted to the propellant gas is then converted into kinetic energy by a nozzle of either physical material construction or by magnetic means.
- ii. Electromagnetic: In this ions are accelerated either by the effect of an electromagnetic fields where the electric field is not in the direction of the acceleration.

Advantages of Electric Propulsion used in the battery electric vehicle that uses chemical energy stored in rechargeable battery packs.

As Electric vehicle, it employs electric motors and motor controllers instead of internal combustion engine

The concept of battery electric vehicle is to charge batteries on board of vehicles for propulsion using the electric grid.

The main advantages of battery electric vehicles are :

1. No pollutants are emitted directly by the vehicle potentially reducing urban pollution.
2. Gasoline is indirectly replaced by whatever is being used to generate domestic electricity, reducing dependence on foreign commodities. The electrical energy stored within the battery can be generated by any source, including renewable, nuclear, natural gas, coal and petroleum.

**Q.92** Write short notes on

(i) three-phase connection of a transformer

(ii) Variable frequency operation of transformer (8)

**Ans:**

- (i) There are various methods available for transforming voltage to higher or lower  $3\Phi$  voltage i.e. for handling considerable amount of power. The most common connections are (i) Y-Y (ii)  $\Delta - \Delta$  (iii) Y- $\Delta$  (iv)  $\Delta$ -Y (v) open-delta or V-V (vi) scott- connection or T-T connection.

**Y-Y connection :** Most economical for small high voltage transformers because no. of turns/phase and amount of insulation required is minimum ( $1/\sqrt{3}=V_p/V_L$ ) This connection works only if the load is balanced. With unbalanced load to neutral, the neutral point shifts making the 3 phase-voltage unequal. It was a phase shift of  $30^\circ$  between phase and line voltage in both  $\Delta$ - $\Delta$  connection. It is economical for large, low voltage transformers where insulation problem is not so urgent, because it increases the no. of turns/phase. The  $3-\Phi$  voltage remains practically constant regardless of load imbalance. Even if one Transformer becomes disable, system continues to operate in V-V although with reduced available capacity of 58% of normal value. There is no internal phase-shift between  $V_p$  &  $V_L$ . Voltage are sinusoidal because of presence of  $3^{rd}$  harmonic in magnetizing current.

**Y- $\Delta$  Connection:**

Used at substation end of transmission line where voltage is stepped down. There is  $30^\circ$  shift between primary and secondary line voltages which means Y- $\Delta$  can be

paralleled with Y-Y or  $\Delta$ - $\Delta$  bank. 3<sup>rd</sup> harmonic flows in  $\Delta$  to provide a sinusoidal flux  $V_{LS}/V_{LP} = k/\sqrt{3}$

**$\Delta$ -Y connection:**

Used at beginning of high TTS to step up the voltage. Because of 30° shift it is impossible to paralleled such bank with  $\Delta$ - $\Delta$  or Y-Y even if voltages ratio correctly adjusted. Best suited for 3 $\Phi$ , 4 wire service.  $V_{LS}/V_{LP} = \sqrt{3} k$ .

**Open delta** or V-V connection: Method of transforming 3 $\Phi$  power by means of only transformer at a reduced rate of 58% of normal value. Ratio of operating capacity to available capacity of an V-V is 0.866 (utility factor). Overload on each of transformer is 73.2%. The addition of 3<sup>rd</sup> transformer increases total capacity by  $\sqrt{3}$  or 173.2%.

**Scott or T-T connection :**

**(ii) Variable Frequency operation of transformer:**

Change in frequency affects the operation of a transformer in the following ways:

- i. Iron Loss – Increases with a decrease in frequency. A 60 Hz transformer will have nearly 11% higher losses, when worked on 50 Hz instead of 60 Hz. However, when a 25 Hz transformer is worked on 60Hz, iron losses are reduced by 25%.
- ii. Cu Loss – In distribution transformer, it is independent of frequency.
- iii. Efficiency- Since Cu loss is unaffected by change in frequency, a given transformer efficiency is less at a low frequency than at a higher one.
- iv. Regulation – Regulation at unit power factor is not affected because IR drop is independent of frequency. Since reactive drop is affected, regulation at low power factor decreases with decrease in frequency and vice versa. For example, the regulation of a 25 Hz transformer when operated at 50 Hz and low power factor is much poorer.
- v. Heating – Since total loss is greater at a lower frequency, the temperature is increased with decrease in frequency.

**Q.93** Explain the constructional features of synchronous generator. What are the two types of generators? Derive emf equation of a synchronous machine. **(10)**

**Ans:** Constructional feature of synchronous generator ;

A synchronous generator or alternator consists of an armature winding and a magnetic field. Armature winding mounted on a stationary element called stator and field winding on a rotating element called rotor.

The stator consists of a cast iron frame which supports the armature core having slots on its inner periphery for housing the armature conductor. The rotor is like a flywheel

having alternate N and S poles fixed to its outer rim. The magnetic poles are excited from direct current supplied by a d.c source which is belted or mounted on the shaft of the alternator itself. Because the field magnets are rotating, this current is supplied through two slip rings. As the exciting voltage is relatively small, the slip ring and brushes gear are of light construction.

Types of synchronous generator :

There are two types of rotor used in synchronous generator. Accordingly, A synchronous generator may be classified as:

- (i) Salient pole type
- (ii) smooth cylindrical type.

Salient pole type has a large number of projecting poles having their cores bolted or dovetailed on to a heavy magnetic wheel of cast iron or steel of good magnetic quality. Such generators are characterized by their large diameter and short axial length.

Smooth cylindrical type runs at very high speed. The rotor consists of a smooth solid forged steel cylinder having a number of slots milled out at intervals along the outer periphery for accommodating field coils. Such rotors are designed mostly for 2 pole turbo generator running at 3600 rpm. These are characterized by small diameter and long axial rotor length. The cylindrical construction of the rotor gives better balance and quieter operation and less windage losses.

E.M.F equation of synchronous machine :

- Let  $Z$  = no. of conductor or coil sides in series / phase.  
 $= 2T$  – where T is the no of coils or turns/phase.
- $P$  = No. of poles.
- $F$  = frequency of induced e.m.f in Hz.
- $\Phi$  = flux /pole in webers
- $K_d$  = distribution factor =  $\frac{\sin m \beta/2}{m \sin \beta/2}$
- $K_C$  &  $K_p$  = Pitch or coil span factor =  $\cos \alpha / 2$
- $K_f$  = form factor = 1.11 – if e.m.f is assumed sinusoidal
- $N$  = rotative speed of the rotor in r.p.m

In one revolution of the rotor (i.e in  $60/N$  seconds) each stator conductor is cut by a flux of  $\Phi_p$  webers

$$d\Phi = \Phi_p \text{ and } dt = 60/N \text{ seconds}$$

$$\therefore \text{average e.m.f induced per conductor} \\ = \frac{d\Phi}{dt} = \frac{\Phi_p}{60/N} = \frac{\Phi N_p}{60} \text{ volts}$$



Now, we know that  $f = pN/120$

$$\text{Or } N = 120f/p$$

Substituting this value of  $N$  above, we get average e.m.f per conductor

$$= \Phi p / (60) \times 120f/p = 2 f \Phi \text{ volts}$$

if there are  $Z$  conductors in series / phase then

$$\text{Average e.m.f / phase} = 2f\Phi Z \text{ volts}$$

$$= 4f\Phi T \text{ volts}$$

$$\text{R.M.S value of e.m.f / phase} = 1.11 \times f \Phi T$$

$$= 4.44 f\Phi T \text{ volts}$$

This would have been the actual value of the voltage induced. All the coils in a phase are :

- (i) full pitched and
- (ii) concentrated or bunched in one slot.

But the actually available voltage is reduced in the ratio of the these two factors.

$\therefore$  actually available voltage / phase.

$$= 4.44 k_c k_d f\Phi T \text{ volts}$$

$$= 4.44 k_f k_c k_d f\Phi T \text{ volts}$$

**Q.94 (a)** Give comparison between squirrel cage and slip ring induction machine? Discuss the working principle of three phase induction motor. (8)

**(b)** State different methods of speed control of three phase induction motor. Explain any one of the method in detail. Also draw torque-speed characteristics. (8)

**Ans: Comparison between Squirrel-cage and Slip ring Induction Machine:**

Almost 90% of induction machines are Squirrel-cage type, because this type of rotor has the simplest and most rugged construction imaginable and is almost indestructible. Rotor is of cylindrical type laminated core.

Rotor bars are permanently short-circuited on themselves, hence it is not possible to add any external resistance in series with rotor circuit for starting purposes.

Rotor slots are skewed for (a) quiet running by reducing magnetic hum. (b) helps in reducing locking tendency of the rotor i.e. tendency of rotor teeth to remain under stator teeth due to direct magnetic attraction.

**Slip ring induction machine :**

This type is provided with distributed winding consisting of coils as used in alternators.

Speed torque/current characteristics can be changed by introduction of additional external resistance in rotor circuit during starting period for increasing starting torque. When running under normal conditions, the slip-rings are automatically short-circuited by means of a metal collar. Then brushes are automatically lifted to reduce fictional losses.

But under normal running conditions wound rotor is short circuited on itself just like squirrel case rotor.

### Working principle of 3 $\Phi$ induction motor :

In A.C. motors, rotor does not receive electric power by conduction but by induction in exactly the same way as the secondary of 2-wdg transformer receives its power from the primary. So such motors are known as induction motors.

The principle of a 3 $\Phi$  2 pole stator having 3 identical wdg placed 120° apart. The flux (assumed sinusoidal) due to 3  $\Phi$  wdg is shown. Let  $\Phi_m$  be maximum value of flux due to any one of the 3 $\Phi$ . The resultant flux  $\Phi_r$  at any instant, is given by vector sum of individual fluxes  $\Phi_1$   $\Phi_2$   $\Phi_3$  due to 3  $\Phi$ . Let us consider values of  $\Phi_r$  at four instants 1/6<sup>th</sup> time period apart corresponding to points marked 0,1, 2 and 3.

- (i) When  $\theta = 0^\circ$  i.e. corresponding to points 0

$$\text{Hence } \Phi_1 = 0, \quad \Phi_2 = \frac{\sqrt{3}}{2} \Phi_m, \quad \Phi_3 = \frac{\sqrt{3}}{2} \Phi_m,$$

$$\Phi_r = 2 \times \frac{\sqrt{3}}{2} \Phi_m \cos \frac{60^\circ}{2} = \sqrt{3} \times \frac{\sqrt{3}}{2} \Phi_m = \frac{3}{2} \Phi_m,$$

- (ii) When  $\theta = 60^\circ$  i.e. corresponding to point 1

$$\text{Here } \Phi_1 = -\frac{\sqrt{3}}{2} \Phi_m$$

$$\Phi_2 = \frac{\sqrt{3}}{2} \Phi_m,$$

$$\Phi_3 = 0$$

- (iii) when  $\theta = 120^\circ$  corresponding to point 2

$$\text{Here } \Phi_1 = -\frac{\sqrt{3}}{2} \Phi_m; \quad \Phi_2 = 0, \quad \Phi_3 = -\frac{\sqrt{3}}{2} \Phi_m$$

$$\Phi_r = \frac{3}{2}$$

(iv) when  $\theta = 180^\circ$  corresponding to point 3

$$\phi_1 = 0, \phi_2 = \frac{\sqrt{3}}{2} \phi_m; \quad \phi_3 = -\frac{\sqrt{3}}{2} \phi_m$$

Hence

1. Resultant flux is  $\frac{3}{2} \phi_m$  i.e. 1.5 times the maximum value of flux due to any phase.
2. Resultant flux rotates around stator at synchronous speed given by  $N_s = 120 f/p$

(b) Different methods of speed control of three phase induction motor

The speed of an induction motor is given by

$$N = (f/p) \times (1-S)$$

Where, N is speed  
F is frequency  
P is the no of poles.  
S is the slip.

Thus speed of three phase induction motor is controlled by the following methods:

- a. Rheostatic control
- b. pole control
- c. cascade control
- d. combination of cascade and pole changing arrangement.
- e. Frequency control

Pole changing method: Winding on the stator may be so arranged that with different connection, different numbers of poles are available which give different speeds. The choice of the number of poles on the pole changing winding is in the ratio 2:1, alternatively independent winding may be provided on the rotor.

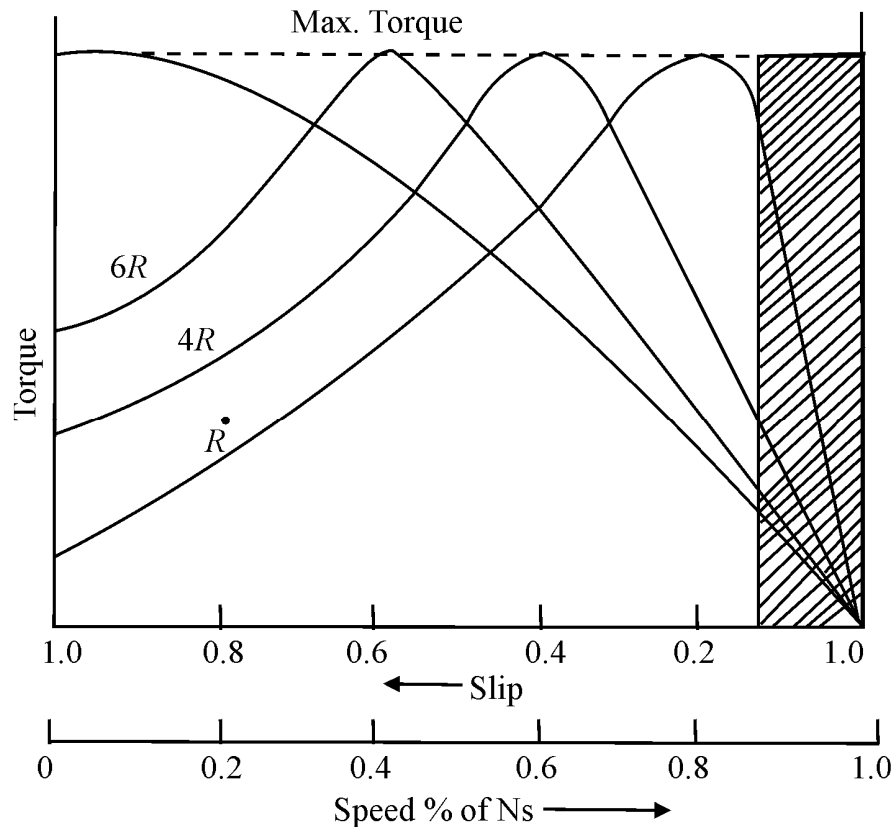
**Torque – speed characteristics of 3- $\Phi$  Induction**

**Q.95** Describe the construction of hysteresis motor and show that it builds a running torque both at synchronous and asynchronous speed of the rotor. (8)

**Ans: Construction of Hysteresis motor:**

The operation of hysteresis motor depends on the presence of a continuously revolving magnetic flux.

The rotor of this motor is a smooth chrome steel cylinder having high retentivity so that the hysteresis loss is high. It has no winding. Because of high retentivity of the rotor material, it is very difficult to change the magnetic polarities. Once they are induced in the rotor by the revolving flux, the rotor revolves synchronously because magnetically stator poles are of opposite polarity.

The fact that the rotor has no teeth or winding of any sort results in making the motor extremely quiet in the operation and free from mechanical and magnetic vibrations. This makes the motor particularly useful for sound equipment applications.

This motor builds a running torque both at synchronous and asynchronous speed of the rotor. It accelerates rapidly, changing from rest to full speed almost instantaneously.

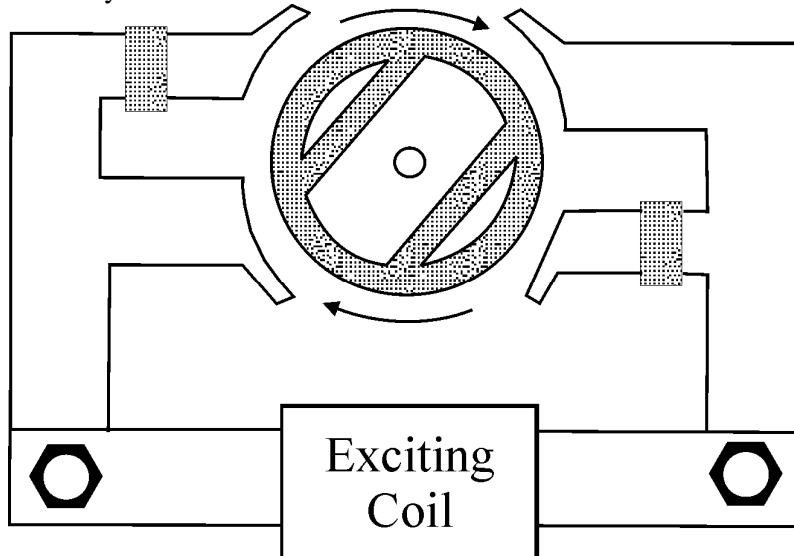

**Q.96** (a) What do you understand by the term cogeneration? Give its significance. (8)

(b) Write short notes on following energy sources

(i) Wind

(ii) Wave

(iii) Bio fuels

(3+3+2)

**Ans:** (a) **Cogeneration** is a high efficiency energy system that produces both electricity (or mechanical energy) and valuable heat from single fuel source. Cogeneration is some times known as combined heat and not only generates power but also provides heat for industrial purposes. For example a hospital cogeneration plant would produce some of power and all hot water needed for its laundry and hot water system from the waste heat it generates.

**Significance :**

It reduces energy costs and green house gas emissions typically by upto two-third. In addition to reduction in cost, cogeneration also increases resource utilization. It offers major economic and environmental facilities because it turns otherwise wasted heat into a useful energy source.

Cogeneration is a proven and reliable technology currently operating at over 100 sites across Australia.

There is significant potential for cogeneration plants fired by other fuels, including biomass (e.g., plant waste from sugar or cotton harvesting), or biogas (e.g., methane produced by sewage works or piggeries).

(b)

(i) Wind

Wind energy used in wind mills to pump water from wells and low level to high level.

Windmills do not generate electricity but are used to grind grains with large grinding stones. Today wind is used to make electricity, blowing wind spins the blades on a wind turbine, which is called wind turbine. The blade of turbine is attached to a hub i.e. mounted on a turning shaft. The shaft goes through a gear transmission box where the turning speed is increased. The transmission is attached to a high-speed shaft, which turn generator that makes electricity. If wind gets too high, turbine has a brake that will keep blades from turning to fast and being damaged. For efficient working, wind speeds must be above 12 to 14 miles/hr., to turn the turbines fast enough to generate electricity. Turbines usually produce 50 to 500 kW of electricity each.

(ii) Wave

Waves are caused by action of winds on sea. Waves can be many meters high and contain a great deal of energy, which can be harnessed to drive turbines that generate electricity.

Wave energy can be harnessed in coastal areas, close to shore. There has been one such device working on the island of Islay in Scotland since early 1990s producing 75 kW of electricity. Wave energy collectors are of 2 main types :

(a) First type directs waves into man-made channels, where the water passes through a turbine that generates electricity.

(b) Second type uses up and down movement of wave to push air.

Advantages : Non-polluting and don't affect wild life.

Disadvantages : Turbines can be unsightly and no constant supply of energy. Wave heights vary.

(iii) Bio fuel:

Bio fuel are transportation fuel like ethanol and bio-diesel that are made from biomass materials. These are usually blended with petroleum fuels-gasoline and diesel fuel, but they can also be used on their own. Ethanol and bio-diesel are expensive than fossil fuels that they replace but are cleaner fuels, producing fewer air pollutants.

Ethanol is an alcohol fuel made from sugars found in grains, such as corn, sorghum and wheat as well as potato skins, rice etc. Most of ethanol in US is distilled from corn.

Bio-diesel is a fuel made with vegetable oils, fats or greases such as recycled restaurant grease. Bio-diesel fuels can be used in diesel engine without changing

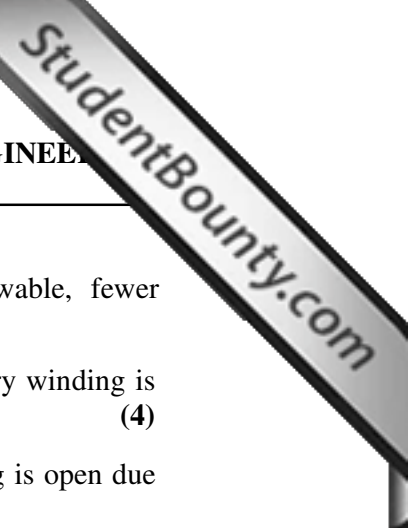

---

them. It is fastest growing alternative fuel in US. A safe, renewable, fewer pollutants,degradable.

**Q.97** Why does a practical transformer draw some current when its secondary winding is open? (4)

**Ans :** Transformer practically draws some current when its secondary winding is open due to primary circuit and this current will produce core losses.