

**Q 2 (a) Discuss the computer controlled systems with the help of its block diagram.**

**Answer** Page Number 2.8 of Text Book

**Q 2 (b) Differentiate the following:**

- (i) Continuous & discrete control systems
- (ii) Open loop & closed loop control system

**Answer**

(i) Page Number 1.6 of Text Book

(ii) Page Number 1.4 of Text Book

**Q 3 (a) A closed loop servo system is represented by the differential equation.**

$$\frac{d^2c}{dt^2} + 8\frac{dc}{dt} = 64e$$

Where  $c$  is the displacement of the output shaft,  $r$  is the displacement of the input shaft and  $e = r - c$ . Determine.

- (i) Damping ratio
- (ii) Damped natural frequency
- (iii) %  $M_p$  for unit step input

**Answer**

$$\frac{d^2c}{dt^2} + 8\frac{dc}{dt} = 64e$$

Putting value of  $e = r - c$  in above of equation.

$$\frac{d^2c}{dt^2} + 8\frac{dc}{dt} = 64(r - c)$$

Taking Laplace transform of above equation, we get

$$s^2C(s) + 8sC(s) = 64[R(s) - C(s)]$$

$$[(s)^2 + 8s + 64]C(s) = 64 R(s)$$

$$\frac{C(s)}{R(s)} = \frac{64}{s^2 + 8s + 64}$$

Comparing above equation with second order equation

$$\frac{C(s)}{R(s)} = \frac{\omega_n^2}{s^2 + 2\zeta\omega_n s + \omega_n^2}$$

We get

$$\omega_n = 5$$

$$\varepsilon = 0.5$$

Putting values of

$$\omega_n = 5$$

$$\varepsilon = 0.5$$

In equation

$$\%M = e^{\frac{-\pi \times 0.5}{\sqrt{1-0.5^2}}} \times 100$$

We get,

$$\%M = 16.11\%$$

**Q 3 (b) Derive the unit step response to a second order system.**

Answer Page Number 3.15 of Text Book

**Q 4 (a) Determine the transfer function of a control system shown in Fig. 2:**

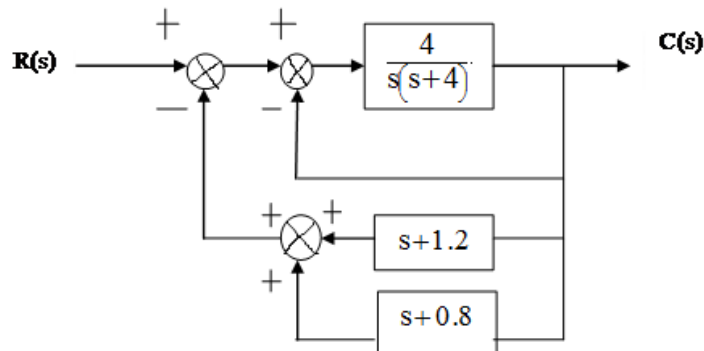

**Fig.2**

Answer 
$$\frac{C}{R} = \frac{4}{(s+2)(s+6)}$$

**Q 5 (a) Draw the signal flow graph for the block diagram in given Fig. 3 and obtain the transfer function C(s)/R(s).**

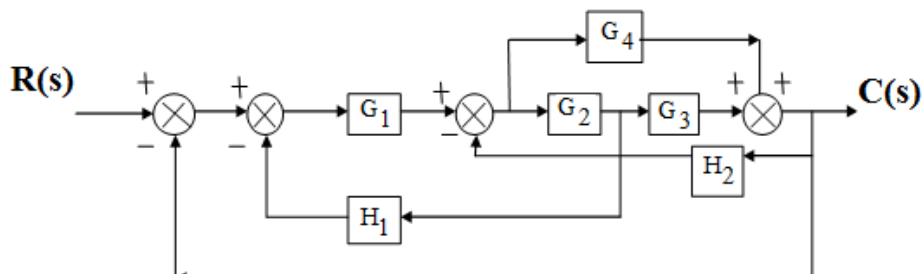

**Answer**

$$\text{Transfer function} = \frac{G_1 G_4 + G_1 G_2 G_3}{1 + G_4 H_2 + G_4 G_1 + G_2 G_3 H_2 + G_1 G_2 G_3 + G_1 G_2 H_1}$$

**Q 5 (b) Write down Mason's gain formula and explain each term therein.**

**Answer**

The gain formula is as follows:

$$M = \frac{y_{out}}{y_{in}} = \sum_{k=1}^N \frac{M_k \Delta_k}{\Delta}$$

where:

- $\Delta$  = the determinant of the graph.
- $y_{in}$  = input-node variable
- $y_{out}$  = output-node variable
- $G$  = complete gain between  $y_{in}$  and  $y_{out}$
- $N$  = total number of forward paths between  $y_{in}$  and  $y_{out}$
- $G_k$  = gain of the  $k$ th forward path between  $y_{in}$  and  $y_{out}$
- $L_i$  = loop gain of each closed loop in the system
- $L_i L_j$  = product of the loop gains of any two non-touching loops (no common nodes)
- $L_i L_j L_k$  = product of the loop gains of any three pairwise nontouching loops
- $\Delta_k$  = the cofactor value of  $\Delta$  for the  $k$ th forward path, with the loops touching the  $k$ th forward path removed. \*

**Q 6 (a) Explain various time domain specifications used for design of feedback control system.**

**Answer** Page Number 10.6 of Text Book

**Q 8 (a) Draw the root locus plot for a unity feedback control system having open**

**loop transfer function as**  $G(s) = \frac{k(s+2)}{s(s+1)(s+4)}$ .

**Determine:**

- (i) Centroid**
- (ii) Angles of a asymptotes**
- (iii) Breakaway point, if any**

**Answer**

(i) Centroid:  $= \frac{-3}{2}$

(ii) Angle of asymptotes:  $90^\circ$  and  $270^\circ$

(iii) break away  $s = -0.55$

**Q 8 (b) Write the method for finding the angle of departure from a complex pole in a root locus plot.**

**Answer** Page Number 13.7 of Text Book

**Q 9 (a) Obtain Bode Plots for the system:**  $G(s) = \frac{1000}{(0.1s + 1)(0.001s + 1)}$

**Also obtain GM and PM. Comment on stability.**

**Answer** Put  $s = j\omega$

$$G(j\omega) = \frac{1000}{(0.1j\omega + 1)(0.001j\omega + 1)}$$

The given transfer function is of type '0' system. Therefore the initial slope of the bode plot is 0db/decade. The starting point is given by

$$20\log_{10} K = 20\log_{10} 1000 = 60 \text{ db}$$

Corner frequencies  $\omega_1 = \frac{1}{0.1} = 10 \text{ rad/sec.}$

$$\omega_2 = \frac{1}{0.001} = 100 \text{ rad/sec.}$$

Mark the starting point 60db on y-axis and draw a line of slope 0db/decade up to first corner frequency

From first corner frequency to second corner frequency draw a line with slope  $(0-20) = -20 \text{ db/decade}$

From second corner frequency to next corner frequency draw a line having the slope  $-20 + (-20) = -40 \text{ db/decade.}$

The magnitude plots are complete and now draw the phase plot by calculating the phase at different frequencies

From the bode plot

From the point of intersection of magnitude curve with 0 db axis draw a line on phase curve. This line cuts the phase curve at  $-154^\circ$

Therefore  $P.M = -154 - (-180) = +26^\circ$  , Gain Margin  $G.M = \infty$

Since,  $P.M = +26$  and gain margin  $= \infty$  , the system is inherently stable.

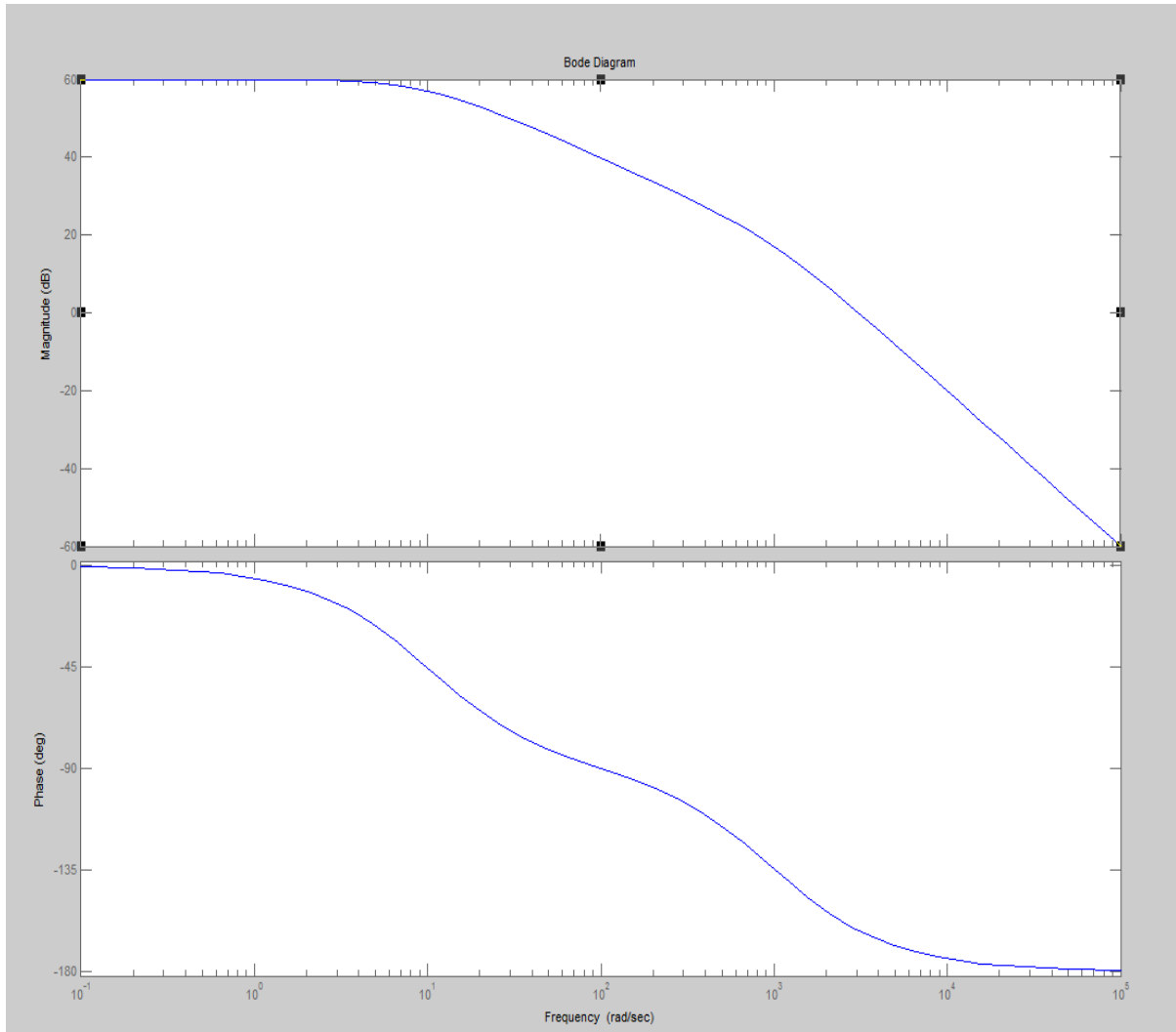

**Q 9 (b) Discuss the general procedure of determination of transfer function from bode plot**

**Answer** Page Number 15.17 of Text Book

**Text Book**

**Feedback and Control Systems (Schaum's Outlines), Joseph J DiStefano III, Allen R.Stubberud and Ivan J. Williams, 2nd Edition, 2007, Tata McGraw-Hill Publishing Company Ltd.**