

Time: 3 Hours

JUNE 2013

Max. Marks: 100

PLEASE WRITE YOUR ROLL NO. AT THE SPACE PROVIDED ON EACH PAGE IMMEDIATELY AFTER RECEIVING THE QUESTION PAPER.

NOTE: There are 9 Questions in all.

- Question 1 is compulsory and carries 20 marks. Answer to Q.1 must be written in the space provided for it in the answer book supplied and nowhere else.
- The answer sheet for the Q.1 will be collected by the invigilator after 45 minutes of the commencement of the examination.
- Out of the remaining EIGHT Questions answer any FIVE Questions. Each question carries 16 marks.
- Any required data not explicitly given, may be suitably assumed and stated.

Q.1 Choose the correct or the best alternative in the following: (2×10)

a. An ideal voltage source is that which has an internal resistance _____ ohms.

- | | |
|------------|--------------|
| (A) zero | (B) one |
| (C) 1 Mega | (D) Infinite |

b. The Inverse Laplace Transform of $\frac{2}{(s+1)}$ is _____

- | | |
|---------------|----------------|
| (A) $2(t+1)$ | (B) $2e^{-2t}$ |
| (C) e^{-2t} | (D) $2e^{-t}$ |

c. _____ parameters are widely used in transmission line

- | | |
|--------------------|-----------------|
| (A) Z-parameter | (B) Y-parameter |
| (C) ABCD-parameter | (D) h-parameter |

d. VSWR on short circuited loss less device is _____

- | | |
|-------|--------------|
| (A) 0 | (B) ∞ |
| (C) 1 | (D) -1 |

e. A parallel resonant circuit can be used _____

- | | |
|-------------------------|---|
| (A) as a high impedance | (B) to reject small band of frequencies |
| (C) both (A) & (B) | (D) to amplify certain frequencies |

f. A transmission line is terminated in a load equal to its characteristic impedance. The reflection co-efficient is _____

- | | |
|-------|--------------|
| (A) 1 | (B) -1 |
| (C) 0 | (D) ∞ |

Code: DE57

Subject: NETWORKS AND TRANSMISSION

- g. Double stub matching eliminates standing waves on the _____
- (A) source side of the left stub (B) load side of the right stub
(C) both sides of the stub (D) in between the two stubs
- h. One Neper is equal to
- (A) 0.8686 dB (B) 8.686 dB
(C) 0.6930 dB (D) 3 dB
- i. A Smith Chart is used for solving problems in _____
- (A) radio wave propagation (B) transmission line
(C) antenna systems (D) power transfer problems
- j. The attenuator where series arm R_A is usually made equal to characteristic impedance is a _____
- (A) symmetrical T attenuator (B) symmetrical π attenuator
(C) bridged T attenuator (D) lattice T attenuator

Answer any FIVE Questions out of EIGHT Questions.
Each question carries 16 marks.

- Q.2** a. Classify the various types of network elements and explain each of them with examples. (8)
- b. To a $2\mu\text{F}$ condenser is applied a voltage $v(t)$ as shown in Fig.1. Find:
- (i) the current during time $t = 0$ to $t = 1$ second.
(ii) charge accumulated across the condenser at $t = 1$ second.
(iii) power in the condenser at $t = 1$ second
(iv) energy stored in the condenser at $t = 1$ second. (8)

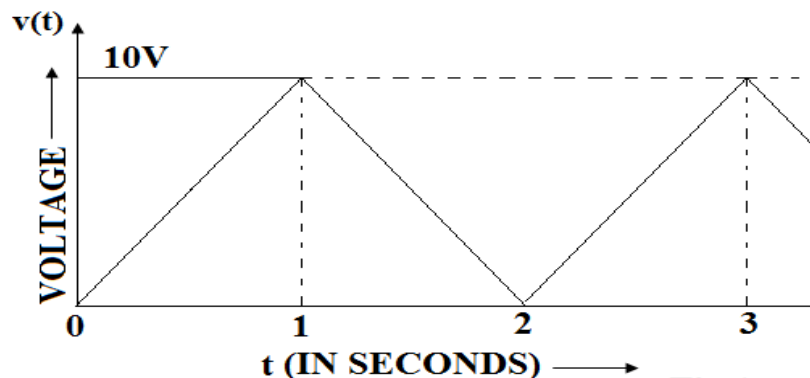

- Q.3** a. Discuss the advantages of Laplace Transform method over classical method? (5)
- b. Find Laplace Transform of:
- (i) Unit Impulse function (ii) Unit ramp function (6)

- c. Find the convolution integral when $f_1(t) = e^{-at}u(t)$ and $f_2(t) = t u(t)$, using Laplace transform. (5)

- Q.4** a. Apply Routh-Hurwitz criterion to check the stability of system whose characteristic equation is given by $s^5 + s^4 + 4s^3 + 24s^2 + 3s + 63 = 0$. Also determine the number of roots
 (i) with positive real parts
 (ii) with zero real parts
 (iii) with negative real parts (9)

- b. Obtain the ABCD Parameters of the network shown in Fig.2 and verify that the circuit is symmetrical and reciprocal. (7)

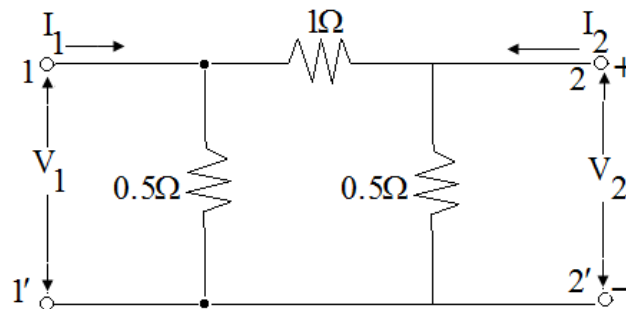

Fig.2

- Q.5** a. The voltage applied to a series RLC circuit is 0.85V. The Q of the inductor coil is 50 and the value of the capacitor is 320 pF. The resonant frequency of the circuit is 175 KHz. Find:
 (i) the value of inductance
 (ii) the value of resistance
 (iii) the voltage across capacitor (6)

- b. Compare the frequency response curve of an amplifier with single and double tuned circuits and discuss the use of double tuned circuits in Radio Receivers. (10)

- Q.6** a. State Thevenin's Theorem and find the current flowing through the load resistor 22Ω in the circuit shown in Fig.3 by applying Thevenin's theorem. (8)

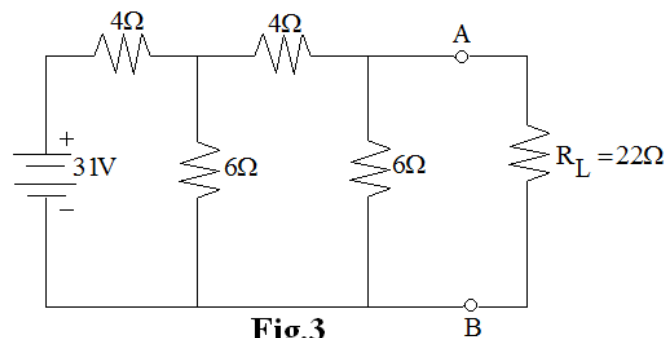

Fig.3

- b. In the network shown in Fig.4, the load connected across terminals AB consists of a variable resistance, R_L and a capacitive reactance X_L which may vary from 2Ω to 8Ω . Determine:

Code: DE57

Subject: NETWORKS AND TRANSMISSION

- (i) the value of R_L and X_L which result in maximum power transfer
 (ii) the maximum power delivered to the load. (8)

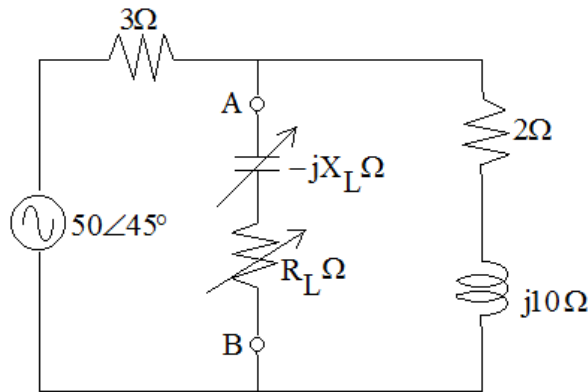

Fig.4

- Q.7** a. The primary constants of a transmission line per loop kilometre are $R = 196\Omega$, $C = 0.09\mu\text{F}$, $L = 0.71\text{mH}$ and leakage conductance is negligible. Calculate the secondary constants at a frequency of $\left(\frac{5,000}{2\pi}\right)\text{Hz}$. (6)
- b. An underground cable has $Z_o = 400\angle -40^\circ$, $\alpha = 0.079\text{neper/Km}$ and $\beta = 0.084\text{ radians/Km}$. If the receiving end current $I_R = 0.005\angle -190^\circ$ and the line is terminated by an impedance $Z_R = 600\angle -20^\circ$, calculate:
 (i) the reflection coefficient
 (ii) voltage in the line at a distance of 10 Km from the receiving end
 (iii) current in the line at a distance of 10 Km from the receiving end (10)
- Q.8** a. What is meant by quarter wave transformer? Why is it also called as impedance inverter? Discuss its applications in transmission lines. (10)
- b. The VSWR measured on UHF transmission line working at a frequency of 300 MHz is found to be 2. If the distance between load and voltage minimum is 0.8 metre, calculate the value of load impedance. (6)
- Q.9** a. Design an m-derived T-section low pass filter having cut-off frequency $f_c = 1000\text{Hz}$, design impedance $R_K = 600\Omega$ and frequency of infinite attenuation $f_\infty = 1050\text{Hz}$. (8)
- b. Write short notes on:
 (i) Asymmetrical T-attenuator
 (ii) Asymmetrical L-attenuator (8)